

Kitchen Collection Pricelist

COEFFICIENTE D'ACQUISTO
PURCHASE COEFFICIENT

1,16

novembre | november 2024

COMPREX

INDICE

index
index
índice
index

INTRODUZIONE Introduction Introduction Introducción Einleitung	P. 3
BASI CON MANIGLIA Base units with handle Bases avec poignée Bases con tirador Unterschränke mit Griff	P. 33
BASI CON GOLA Base units with groove Bases avec rainure Bases con uñero Unterschränke mit Griffleiste	P. 61
COLONNE Tall units Colonnes Columnas Hochschränke	P. 89
PENSILI Wall cabinets Modules suspendus Colgantes Hängeschränke	P. 187
ELEMENTI SPECIALI Special Elements Éléments spéciaux Elementos especiales Besondere Elemente	P. 237
MANIGLIE, PRESE, GOLE, ZOCCOLI Handles, grip, groove, plinths Poignées, prises, plinthes Tiradores, tomas, uñeros, zócalos Griffe, Steckdosen, Sockelleisten	P. 261
ILLUMINAZIONE Lighting Eclairage Iluminación Beleuchtung	P. 291
ACCESSORI Accessories Accessoires Accesorios Zubehör	P. 303
COMPONENTI E MECCANISMI Components and mechanisms Composants et mécanismes Componentes y mecanismos Komponenten und Mechanismen	P. 353
CONDIZIONI GENERALI DI VENDITA General sales conditions Conditions générales de vente Condiciones generales de venta Allgemeine Verkaufsbedingungen	P. 411

COEFFICIENTE D'ACQUISTO
PURCHASE COEFFICIENT

1,16

novembre | november 2024

Basi con maniglia
Base units with handle

Basi con gola
Base units with groove

Colonne
Tall units

Pensili
Wall units

Elementi speciali
Special elements

Maniglie gole zoccoli
Handles grooves plinth

illuminazione
Lighting

Accessori
Accessories

Componenti e meccanismi
Components e mechanism

CARATTERISTICHE TECNICHE GENERALI

General technical characteristics
Caractéristiques techniques générales
Características técnicas generales
Allgemeine technische Merkmale

STRUTTURA

Realizzata con pannelli di particelle di legno, spessore 18 mm, a bassa emissione di formaldeide certificati FSC misto perché fatti con una combinazione di legno/cellulosa proveniente da foreste certificate FSC, con emissioni di formaldeide certificate secondo normativa CARB P2, nobilitati due lati cenere, grafite. Bordatura frontale in ABS spessore 1 mm e restanti bordature in PVC spessore 0,3 mm. Tutte le scocche con larghezza superiore a 120 cm sono fornite con ripiani rinforzati con un profilo in alluminio anodizzato nero per limitare la flessione. Questo sistema di rinforzo può essere richiesto come optional per le scocche con larghezza inferiore a 120 cm.

STRUCTURE

Made of wood particleboard, 18 mm thick, low formaldehyde emission FSC-certified mixed because made with a combination of wood/cellulose from FSC-certified forests, with formaldehyde emissions certified according to CARB P2 standard, two-sided ash, graphite melamine faced. Front ABS edging 1 mm thick and remaining PVC edging 0.3 mm thick. All shells over 120 cm wide are supplied with shelves reinforced with a black anodized aluminum profile to limit bending. This reinforcement system can be requested as an option for shells less than 120 cm wide.

STRUCTURE

Réalisé en panneaux de particules de bois, épaisseur 18 mm, à faible émission de formaldéhyde, certifié FSC car composé d'une combinaison de bois/cellulose provenant de forêts certifiées FSC, avec des émissions de formaldéhyde certifiées selon la norme CARB P2, frêne double face, graphite. Chant frontal en ABS de 1 mm d'épaisseur et chant restant en PVC de 0,3 mm d'épaisseur. Tous les corps d'une largeur supérieure à 120 cm sont fournis avec des tablettes renforcées par un profilé en aluminium anodisé noir pour limiter la flexion. Ce système de renforcement peut être demandé en option pour les coques de moins de 120 cm de large.

ESTRUCTURA

Fabricado con tableros de partículas de madera de 18 mm de grosor, de baja emisión de formaldehído con certificación FSC mixtos porque están fabricados con una combinación de madera/celulosa procedente de bosques con certificación FSC, con emisiones de formaldehído certificadas según la norma CARB P2, fresno de doble cara, grafito. Canto delantero de ABS de 1 mm de grosor y canto restante de PVC de 0,3 mm de grosor. Todos los cuerpos de anchura superior a 120 cm se suministran con estantes reforzados con un perfil de aluminio anodizado negro para limitar la flexión. Este sistema de refuerzo puede solicitarse opcionalmente para los cuerpos de anchura inferior a 120 cm.

STRUKTUR

Aus Holzspanplatten, 18 mm stark, niedrige Formaldehyd-Emissionen, FSC-zertifiziert, gemischt aus einer Kombination von Holz/Zellulose aus FSC-zertifizierten Wäldern, mit Formaldehyd-Emissionen zertifiziert nach CARB P2-Standard, beidseitig Esche, Graphit. Vordere ABS-Kante 1 mm dick und übrige PVC-Kante 0,3 mm dick. Alle Aufbauten mit einer Breite von mehr als 120 cm werden mit Regalböden geliefert, die mit einem schwarz eloxierten Aluminiumprofil verstärkt sind, um die Biegung zu begrenzen. Dieses Verstärkungssystem kann als Option für Schalen mit einer Breite von weniger als 120 cm angefordert werden.

PIEDINI

L'allineamento delle basi al piano di lavoro si ottiene agendo sulla vite posta alla base dei piedini, mentre il perfetto assemblaggio è consentito dai fori di giunzione presenti sui fianchi delle basi, colonne e pensili. I piedini sono realizzati in tecnopolimero e disponibili in altezza 6 o 10 cm con regolazione fino a 1,5 cm. Nel caso di basi o colonne a terra viene utilizzato il piedino H 1 cm, annegato nei fianchi, che permette una regolazione in altezza dell'elemento da 1 a 2,5 cm.

FEET

Alignment of the bases to the worktop is achieved by acting on the screw located at the base of the feet, while perfect assembly is enabled by the joint holes on the sides of the bases, columns and wall units. The feet are made of technopolymer and available in heights of 6 or 10 cm with adjustment up to 1.5 cm. In the case of floor-standing bases or columns, the H 1-cm foot is used, embedded in the sides, which allows height adjustment of the element from 1 to 2.5 cm.

PIEDS

L'alignement des éléments bas sur le plan de travail s'effectue en tournant la vis située à la base des pieds, tandis que l'assemblage parfait est assuré par les trous de jonction situés sur les côtés des éléments bas, hauts et muraux. Les pieds sont en technopolymère et sont disponibles en hauteurs de 6 ou 10 cm avec un réglage jusqu'à 1,5 cm. Dans le cas des unités de base ou des unités hautes à poser au sol, on utilise le pied H 1 cm, encastré dans les côtés, qui permet de régler la hauteur de l'élément de 1 à 2,5 cm.

PATAS

La alineación de los muebles bajos con la encimera se consigue actuando sobre el tornillo situado en la base de los pies, mientras que el ensamblaje perfecto es posible gracias a los orificios de unión situados en los laterales de los muebles bajos, altos y altos. Los pies son de tecnopolímero y están disponibles en alturas de 6 ó 10 cm con ajuste hasta 1,5 cm. En el caso de los muebles bajos o altos de suelo, se utiliza el pie H de 1 cm, empotrado en los laterales, que permite ajustar la altura del elemento de 1 a 2,5 cm.

FÜSSE

Die Ausrichtung der Unterschränke auf der Arbeitsplatte erfolgt durch Drehen der Schraube an der Basis der Füße, während die Verbindungslöcher an den Seiten der Unter-, Hoch- und Oberschränke eine perfekte Montage ermöglichen. Die Füße bestehen aus Technopolymer und sind in Höhen von 6 oder 10 cm mit einer Verstellung bis zu 1,5 cm erhältlich. Bei bodenstehenden Unterschränken oder Hochschränken wird der in die Seiten eingelassene Fuß H 1 cm verwendet, mit dem sich die Höhe des Elements von 1 bis 2,5 cm einstellen lässt.

VUOTO SANITARIO

In tutti i mobili è previsto un vuoto sanitario di 3,5 cm sul retro, per la ventilazione e per facilitare il passaggio di cavi elettrici e tubi.

SANITARY VACUUM

A 3.5-cm sanitary void is provided in all cabinets at the back for ventilation and to facilitate the passage of electrical cables and pipes.

VIDE SANITAIRE

Dans toutes les armoires, il y a un espace sanitaire de 3,5 cm à l'arrière pour la ventilation et pour faciliter le passage des câbles électriques et des tuyaux.

VACÍO SANITARIO

En todos los armarios hay un hueco sanitario de 3,5 cm en la parte trasera para ventilación y para facilitar el paso de cables eléctricos y tuberías.

SANITÄRES VAKUUM

In allen Schränken befindet sich an der Rückseite ein 3,5 cm breiter Spalt für die Belüftung und den Durchgang von elektrischen Kabeln und Rohren.

Basi con maniglia
Base units with handle

Basi con gola
Base units with groove

Colonne
Tall units

Pensili
Wall units

Elementi speciali
Special elements

Maniglie gole zoccoli
Handles grooves plinth

Illuminazione
Lighting

Accessori
Accessories

Componenti e meccanismi
Components e mechanism

CARATTERISTICHE TECNICHE GENERALI

General technical characteristics
Caractéristiques techniques générales
Características técnicas generales
Allgemeine technische Merkmale

ATTACCAGLIE

Le attaccaglie montate sui pensili, basi e colonne profondità 34/44 cm hanno una portata massima di 100 kg a coppia e sono regolabili dall'interno tramite preforature sulla schiena nascoste da copriforo fornito in dotazione.

ATTACHMENTS

Attachments mounted on wall, base and tall units 34/44 cm deep have a maximum load capacity of 100 kg per pair and are adjustable from the inside through pre-drilled holes in the back hidden by hole covers provided.

PIÈCES JOINTES

Les fixations montées sur le mur, les meubles bas et les meubles hauts de 34/44 cm de profondeur ont une capacité de charge maximale de 100 kg par paire et sont réglables de l'intérieur au moyen de trous pré-perçés à l'arrière, dissimulés par les cache-trous fournis.

ARCHIVOS ADJUNTOS

Las fijaciones montadas en la pared, la base y los armarios altos de 34/44 cm de profundidad tienen una capacidad de carga máxima de 100 kg por par y son ajustables desde el interior mediante orificios pretaladrados en la parte posterior ocultos por las tapas de los orificios suministradas.

ANHÄNGE

Die an der Wand montierten Aufsätze, Unter- und Hochschränke mit einer Tiefe von 34/44 cm haben eine maximale Tragfähigkeit von 100 kg pro Paar und sind von innen durch vorgebohrte Löcher in der Rückseite verstellbar, die durch mitgelieferte Lochabdeckungen verdeckt werden.

CASSETTI E CESTONI

I cassetti e cestoni interni (AVANTECH YOU HETTICH) sono realizzati in metallo verniciato colore Hetan (antracite). Sono dotati di guide ad estrazione totale con rallentatore integrato, estremamente silenziose e con ottima portata, complete di regolazioni nelle tre direzioni. Le sponde hanno uno spessore 13 mm, le viti di regolazione e di fissaggio del frontale sono totalmente a scomparsa. Le sponde hanno la possibilità di avere un sistema di illuminazione che illumina il bordo superiore rendono unico questo prodotto.

DRAWERS AND BASKETS

Internal drawers and baskets (AVANTECH YOU HETTICH) are made of metal painted Hetan (anthracite) colour. They are equipped with full-extension runners with built-in slow motion, extremely quiet and with excellent load-bearing capacity, complete with adjustments in all three directions. The side rails are 13 mm thick, and the screws for adjusting and fixing the front are totally concealed. The side rails have the option of having a lighting system that illuminates the top edge make this product unique.

TIROIRS ET PANIERS

Les tiroirs et les paniers intérieurs (AVANTECH YOU HETTICH) sont en métal peint Hetan (anthracite). Ils sont équipés de glissières à sortie totale avec ralentissement intégré, extrêmement silencieuses et d'une excellente capacité de charge, avec réglage dans les trois directions. Les rails latéraux ont une épaisseur de 13 mm et les vis de réglage et de fixation de la façade sont totalement dissimulées. Les rails latéraux peuvent être dotés d'un système d'éclairage qui illumine le bord supérieur, ce qui rend ce produit unique.

CAJONES Y CESTAS

Los cajones y cestas interiores (AVANTECH YOU HETTICH) son de metal pintado Hetan (antracita). Están equipados con guías de extracción total con movimiento lento integrado, extremadamente silenciosas y con excelente capacidad de carga, completas con ajustes en las tres direcciones. Las barandillas laterales tienen un grosor de 13 mm, y los tornillos de ajuste y fijación del frente están totalmente ocultos. Las barandillas laterales tienen la opción de disponer de un sistema de iluminación que ilumina el borde superior, lo que hace que este producto sea único.

SCHUBLADEN UND KÖRBE

Die Schubladen und Innenkörbe (AVANTECH YOU HETTICH) sind aus Hetan (anthrazit) lackiertem Metall gefertigt. Sie sind mit Vollauszügen mit integrierter Langsamlauffunktion ausgestattet, extrem leise und mit hervorragender Tragfähigkeit, komplett mit Verstellungen in allen drei Richtungen. Die Seitenschienen sind 13 mm stark, und die Schrauben für die Einstellung und Befestigung der Front sind vollständig verdeckt. Die Seitenschienen können mit einem Beleuchtungssystem ausgestattet werden, das die Oberkante beleuchtet, was dieses Produkt einzigartig macht.

CERNIERE

Tutti gli elementi base - colonne - pensili con apertura anta dx o sx sono dotati di cerniere con deceleratore integrato regolabile per chiusura rallentata dell'anta, escluse le colonne frigo. Tutti gli elementi base - colonna con estrazioni sono dotati di chiusura rallentata. Le basi delle cerniere lineari sono complete di regolazioni nelle tre direzioni. Le cerniere sono in metallo finitura galvanica colore Titanio.

HINGES

All base units - tall units - wall units with right or left door opening are equipped with hinges with integrated adjustable decelerator for slow closing of the door, excluding refrigerator columns. All base unit - tall units with pull-outs are equipped with slow closing. Linear hinge bases are complete with adjustments in all three directions. Hinges are made of metal galvanized finish Titanium colour.

CHARNIÈRES

Tous les meubles bas - hauts - hauts avec ouverture de porte à droite ou à gauche sont équipés de charnières avec ralentisseur réglable intégré pour une fermeture lente de la porte, à l'exception des meubles hauts avec réfrigérateur. Tous les meubles bas - meubles hauts avec coulissants sont équipés d'un mécanisme de fermeture lente. Les bases à charnières linéaires sont complètes et réglables dans les trois directions. Les charnières sont en métal avec une finition galvanique de couleur titane.

BISAGRAS

Todos los muebles bajos - altos - altos con apertura de puerta a derecha o izquierda están equipados con bisagras con desacelerador ajustable integrado para el cierre lento de la puerta, excepto los muebles altos frigoríficos. Todos los muebles bajos - altos con extracción están equipados con un mecanismo de cierre lento. Las bases con bisagras lineales se completan con ajustes en las tres direcciones. Las bisagras son de metal con acabado galvanizado de color titanio.

SCHARNIERE

Alle Unterschränke - Hochschränke - Hängeschränke mit rechter oder linker Türöffnung sind mit Scharnieren mit integrierter, einstellbarer Verzögerung zum langsamen Schließen der Tür ausgestattet, ausgenommen Kühlschrankschränke. Alle Unterschränke - Hochschränke mit Auszügen sind mit Slow-Motion-Schließung ausgestattet. Die linearen Scharnierböden sind komplett mit Verstellungen in alle drei Richtungen. Die Scharniere sind aus Metall mit einer galvanischen Titanbeschichtung.

CONSIGLI UTILI PER LA PROGETTAZIONE

Useful design tips
Conseils utiles pour la conception
Consejos útiles de diseño
Nützliche Gestaltungstipps

CONSIGLI UTILI PER LA PROGETTAZIONE

- Disegnare in pianta lo spazio in cui andremo a progettare
- Verificare nelle zone con porte e/o finestre l'eventuale ingombro di davanzali, serramenti o dei cassettoni sporgenti
- Verificare l'altezza massima disponibile da terra a soffitto
- Rilevare la posizione esatta di scarico fumi - allacciamento gas e scarico acqua - prese di corrente - interruttori
- Controllare la perpendicolarità delle pareti

USEFUL DESIGN TIPS

- Draw a plan of the space in which we are going to design
- Check in areas with doors and/or windows for the possible encroachment of windowsills, window frames or the protruding coffers
- Check the maximum available height from floor to ceiling
- Survey the exact location of smoke exhaust - gas connection and water discharge - power outlets - switches
- Check the perpendicularity of the walls

CONSEILS UTILES POUR LA CONCEPTION

- Dessinez un plan de l'espace dans lequel nous allons dessiner
- Vérifier que les zones comportant des portes et/ou des fenêtres ne présentent pas d'appuis de fenêtre, de cadres de fenêtre ou de caissons saillants
- Vérifiez la hauteur maximale disponible du sol au plafond
- Emplacement exact du désenfumage - des raccordements au gaz et à l'eau - des prises de courant - des interrupteurs
- Vérifier la perpendicularité des murs

CONSEJOS ÚTILES DE DISEÑO

- Dibuja un plano del espacio en el que vamos a diseñar
- Compruebe si en las zonas con puertas y/o ventanas sobresalen alféizares, marcos de ventanas o artesones
- Compruebe la altura máxima disponible desde el suelo hasta el techo
- Ubicación exacta de la salida de humos - conexión de gas y agua - enchufes - interruptores
- Comprobar la perpendicularidad de las paredes

NÜTZLICHE GESTALTUNGSTIPPS

- Zeichnen Sie einen Plan des Raums, den wir gestalten werden
- Überprüfen Sie Bereiche mit Türen und/oder Fenstern auf hervorstehende Fensterbänke, Fensterrahmen oder Kassetten
- Überprüfen Sie die maximal verfügbare Höhe vom Boden bis zur Decke
- Genaue Lage des Rauchabzugs - Gas- und Wasseranschluss - Steckdosen - Schalter
- Prüfen Sie die Rechtwinkligkeit der Wände

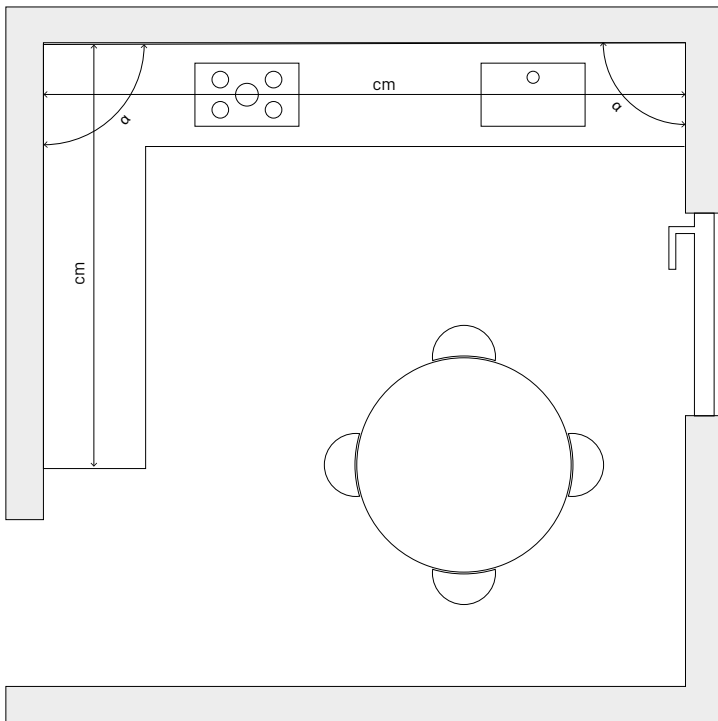



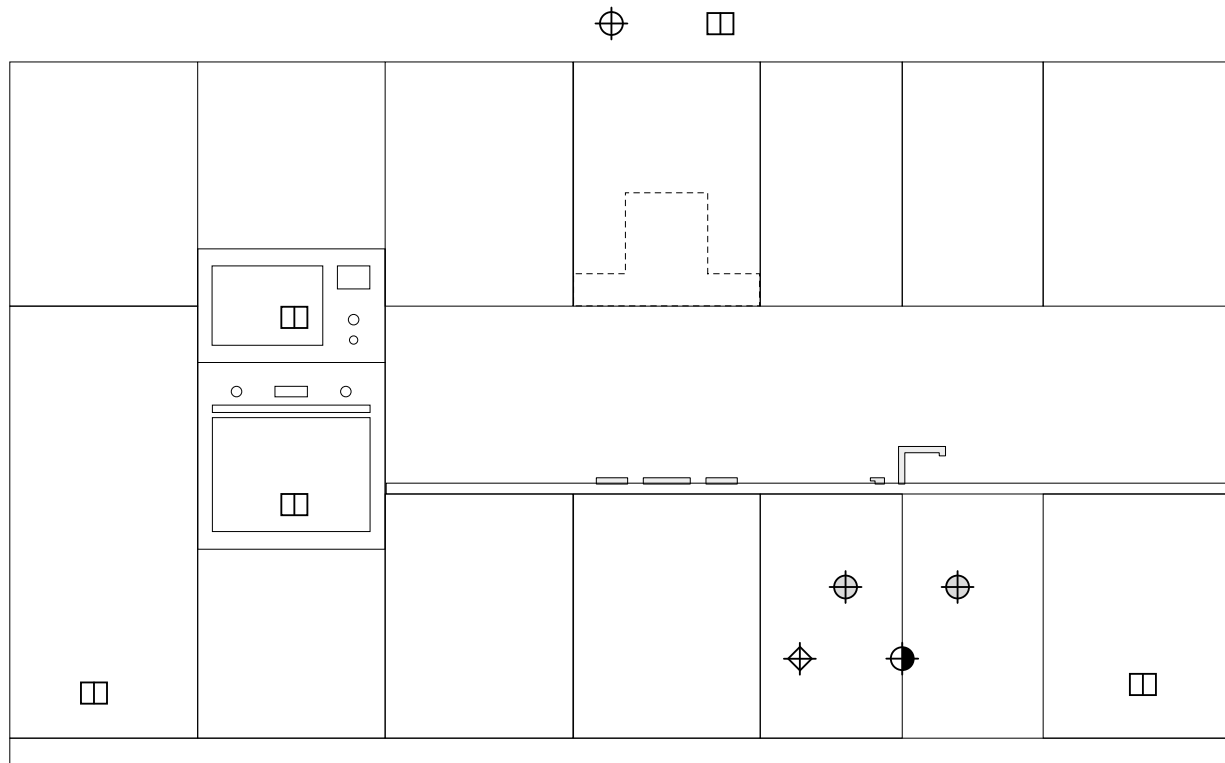

CONSIGLI UTILI PER LA PROGETTAZIONE

Useful design tips
Conseils utiles pour la conception
Consejos útiles de diseño
Nützliche Gestaltungstipps

SCHEMA IMPIANTO ELETTRICO, IDRICO E GAS ELECTRICAL, WATER AND GAS SYSTEM DIAGRAM SCHÉMA DU SYSTÈME ÉLECTRIQUE, DE L'EAU ET DU GAZ ESQUEMA DE LA INSTALACIÓN ELÉCTRICA, DE AGUA Y DE GAS STROM-, WASSER- UND GASNETZPLAN



-  **Pres a elettrica a parete** | Wall socket | Prise murale | Enchufe de pared | Wandsteckdose
-  **Scarico uscita fumi cappa** | Fume hood outlet | Sortie de la hotte | Salida de la campana extractora | Abzugshaubenauslass
-  **Carico acqua per lavello** | Sink water load | Charge d'eau de l'évier | Carga de agua del fregadero | Wasserbelastung der Spüle
-  **Scarico acqua per lavello** | Water drain for sink | Évacuation de l'eau de l'évier | Desagüe del fregadero | Wasserablauf der Spüle
-  **Pres a gas** | Gas outlet | Sortie de gaz | Salida de gas | Gasauslass

CONSIGLI UTILI PER LA PROGETTAZIONE

Useful design tips
Conseils utiles pour la conception
Consejos útiles de diseño
Nützliche Gestaltungstipps

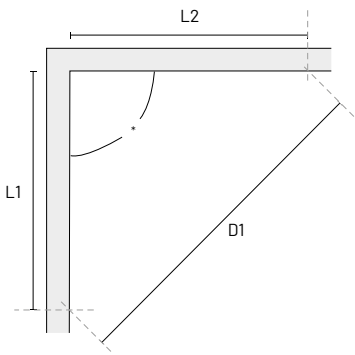
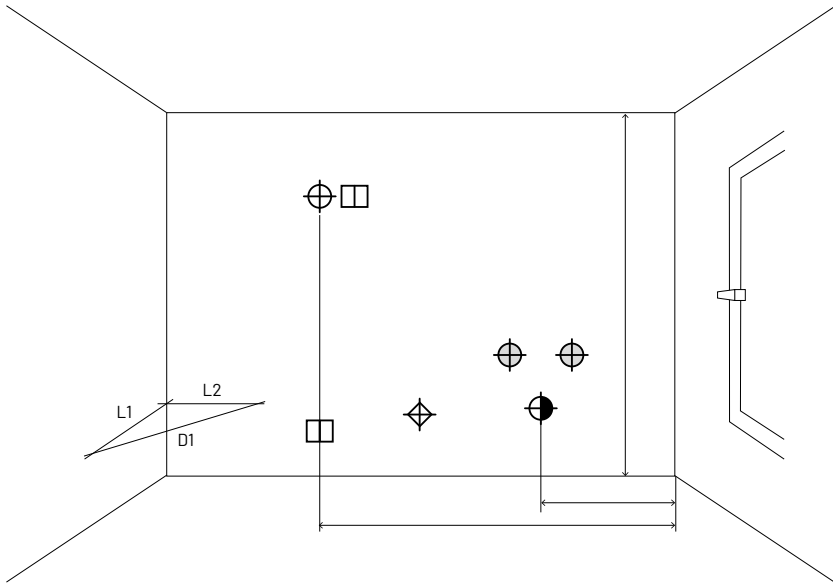

RILIEVO ANGOLO SENZA PILASTRO

Verificare l'angolo tra le pareti attraverso il rilievo delle quote D1 e tramite la tabella di conversione.

CORNER RELIEF WITHOUT AN ABUTMENT

Verify the angle between the walls by surveying the D1 elevation and through the conversion table.

SOULAGEMENT DE L'ANGLE SANS PILIER

Vérifiez l'angle entre les murs en relevant les dimensions D1 et en utilisant le tableau de conversion.

ALIVIO DE ESQUINA SIN PILAR

Verifique el ángulo entre las paredes midiendo las dimensiones D1 y utilizando la tabla de conversión.

ECKENTLASTUNG OHNE WIDERLAGER

Überprüfen Sie den Winkel zwischen den Wänden, indem Sie die D1-Maße messen und die Umrechnungstabelle verwenden.

°	L1(cm)	L2(cm)	D1(cm)
85	100	100	135,1
86	100	100	136,4
87	100	100	137,7
88	100	100	138,9
89	100	100	140,2
90	100	100	141,4
91	100	100	142,6
92	100	100	143,9
93	100	100	145,1
94	100	100	146,3
95	100	100	147,5

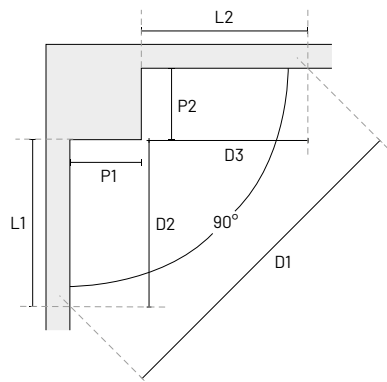

RILIEVO ANGOLO CON PILASTRO

Nel caso di angolo con pilastro è necessario inviare all'ufficio commerciale le seguenti quote: L1 - L2 - P1 - D1 - D2 - D3.

CORNER RELIEF WITH PILLAR

In the case of a corner with an abutment, the following dimensions should be sent to the business office: L1 - L2 - P1 - D1 - D2 - D3.

RELIEF D'ANGLE AVEC PILIER

Dans le cas d'un angle avec un pilier, les dimensions suivantes doivent être envoyées au bureau de vente : L1 - L2 - P1 - D1 - D2 - D3.

RELIEVE DE ESQUINA CON PILAR

En el caso de una esquina con pilar, deberán enviarse a la oficina de ventas las siguientes dimensiones: L1 - L2 - P1 - D1 - D2 - D3.

ECKRELIEF MIT SÄULE

Im Falle einer Ecke mit Widerlager sind folgende Maße an das Verkaufsbüro zu senden: L1 - L2 - P1 - D1 - D2 - D3.

Basi con maniglia
Base units with handle

Basi con gola
Base units with groove

Colonne
Tall units

Pensili
Wall units

Elementi speciali
Special elements

Maniglie gole zoccoli
Handles grooves plinth

Illuminazione
Lighting

Accessori
Accessories

Componenti e meccanismi
Components e mechanism

CONSIGLI UTILI PER LA PROGETTAZIONE

Useful design tips
 Conseils utiles pour la conception
 Consejos útiles de diseño
 Nützliche Gestaltungstipps

VARIAZIONE DIMENSIONI SULLA BASE ANGOLO VARIATION DES DIMENSIONS SUR LA BASE DE L'ANGLE VARIATION DES DIMENSIONS SUR LA BASE DE L'ANGLE VARIACIÓN DE DIMENSIONES EN BASE ANGULAR VARIATION DER ABMESSUNGEN AUF WINKELBASIS

In presenza di basi angolo consigliamo di rilevare sempre le quote LB e PM per verificare la variazione della base in rapporto all'angolo formato dalle pareti.

When corner bases are present, we recommend always taking LB and PM dimensions to check the variation of the base in relation to the angle formed by the walls.

Dans le cas des bases d'angle, nous recommandons de toujours prendre les dimensions LB et PM pour vérifier la variation de la base par rapport à l'angle formé par les murs.

En el caso de las bases de esquina, recomendamos tomar siempre las cotas LB y PM para comprobar la variación de la base en relación con el ángulo formado por las paredes.

Bei Ecksockeln empfehlen wir, immer die Maße LB und PM zu nehmen, um die Abweichung des Sockels im Verhältnis zu dem von den Wänden gebildeten Winkel zu überprüfen.

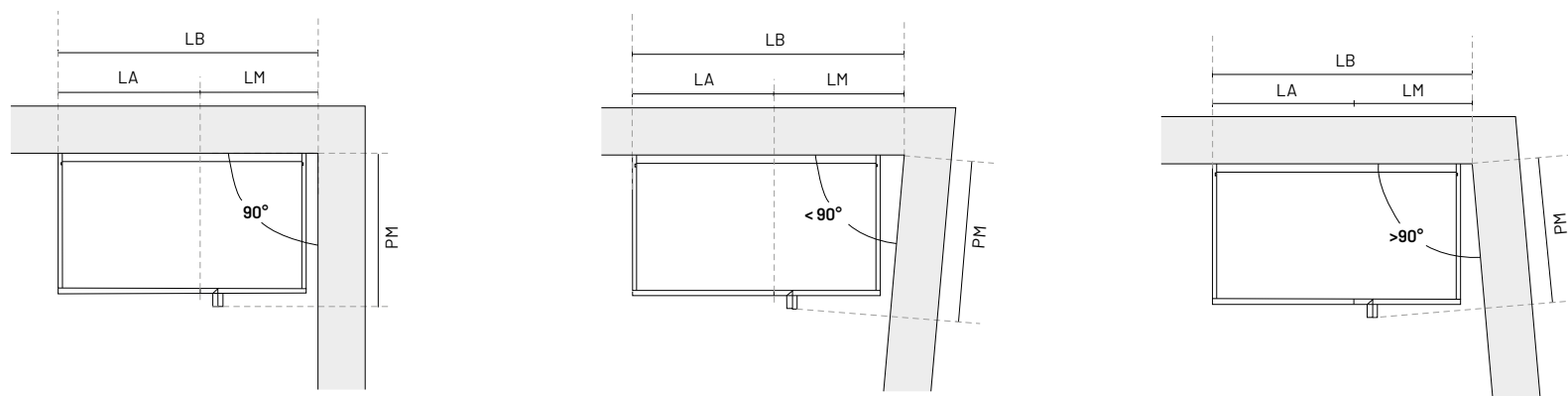

°	LM	PM	LB=LM+LA
89	89	66.1	1.1
88	88	67.1	2.1
87	87	68.2	3.2
86	86	69.3	4.3
85	85	70.5	5.5
90	90	65	
91	91	63.9	1.1
92	92	62.9	2.1
93	93	61.8	3.2
94	94	60.7	4.3
95	95	59.5	5.5

CONSIGLI UTILI PER LA PROGETTAZIONE

Useful design tips
Conseils utiles pour la conception
Consejos útiles de diseño
Nützliche Gestaltungstipps

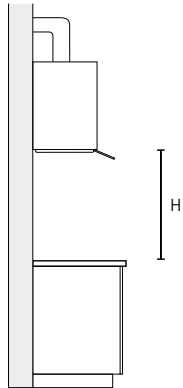

ALTEZZA DEI PENSILI

Distanza minima dai piani di lavoro (cappa per piano cottura a induzione): H. 47 cm

Distanza minima dal piano di lavoro (cappa per piano cottura a gas): H. 50 CM

Se la posizione non viene rispettata decade la garanzia sull'elettrodomestico.

HEIGHT OF WALL CABINETS

Minimum distance from worktops (induction hob hood): H. 47 cm

Minimum distance from worktop (cooker hood for gas hob): H. 50 CM

If the position is not respected, the warranty on the appliance lapses

HAUTEUR DES ARMOIRES MURALES

Distance minimale des plans de travail (hotte à induction) : H. 47 cm

Distance minimale du plan de travail (hotte pour table de cuisson à gaz) : H. 50 CM

Le non-respect de la position entraîne l'annulation de la garantie de l'appareil.

ALTURA DE LOS ARMARIOS ALTOS

Distancia mínima a la encimera (campana de inducción): H. 47 cm

Distancia mínima de la encimera (campana extractora para placa de gas): H. 50 CM

Si no se respeta la posición, se anula la garantía del aparato.

HÖHE DER HÄNGESCHRÄNKE

Mindestabstand von der Arbeitsplatte (Induktionskochfeldhaube): H. 47 cm

Mindestabstand von der Arbeitsplatte (Dunstabzugshaube für Gaskochfeld): H. 50 CM

Bei Nichteinhaltung der Position erlischt die Garantie für das Gerät.

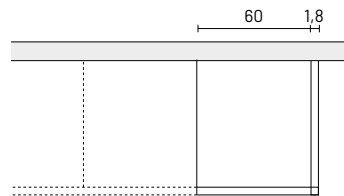

ELETTRODOMESTICI A FINE COMPOSIZIONE

Quando un elettrodomestico (lavastoviglie, frigo, cantinette, ecc...) viene posizionato alla fine di una composizione, prevedere un fianco di chiusura per base, tenendone in considerazione lo spessore per il calcolo del piano di lavoro.

APPLIANCES AT THE END OF THE COMPOSITION

When an appliance (dishwasher, refrigerator, wine cellar, etc.) is placed at the end of a composition, provide a closing side panel per base, taking its thickness into account when calculating the worktop.

APPAREILS À LA FIN DE LA COMPOSITION

Lorsqu'un appareil (lave-vaisselle, réfrigérateur, cave à vin, etc.) est placé à l'extrémité d'une composition, prévoir un panneau latéral de fermeture par base, en tenant compte de son épaisseur dans le calcul du plan de travail.

APARATOS AL FINAL DE LA COMPOSICIÓN

Cuando se coloque un electrodoméstico (lavavajillas, frigorífico, bodega, etc.) al final de una composición, prevea un lateral de cierre por base, teniendo en cuenta su grosor al calcular la encimera.

GERÄTE AM ENDE DER KOMPOSITION

Wenn ein Gerät (Geschirrspüler, Kühlschrank, Weinkeller usw.) am Ende einer Komposition platziert wird, ist eine abschließende Seitenwand pro Sockel vorzusehen, deren Dicke bei der Berechnung der Arbeitsplatte berücksichtigt werden muss.

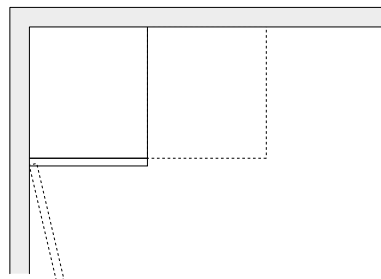

POSIZIONAMENTO A RIDOSSO DELLA PARETE

Il montaggio di una colonna, base o pensile a ridosso di una parete non permette la totale apertura della porta.

Per ovviare al problema consigliamo di posizionare un riempitivo di 5 cm tra parete e mobile.

POSITIONING CLOSE TO THE WALL

Mounting a column, base or wall unit close to a wall does not allow the door to open fully. To overcome this problem, we recommend placing a 2-inch filler between the wall and cabinet.

POSITIONNEMENT PRÈS DU MUR

Le montage d'une colonne, d'un socle ou d'une armoire murale à proximité d'un mur ne permet pas l'ouverture complète de la porte. Pour remédier à ce problème, il est recommandé de placer une cale de 5 cm entre le mur et l'armoire.

COLOCACIÓN CERCA DE LA PARED

El montaje de una columna, base o mueble alto cerca de una pared no permite que la puerta se abra completamente. Para solucionar este problema, recomendamos colocar un relleno de 5 cm entre la pared y el armario.

POSITIONIERUNG IN WANDNÄHE

Wenn eine Säule, ein Unterschrank oder ein Oberschrank dicht an der Wand montiert wird, lässt sich die Tür nicht vollständig öffnen. Um dieses Problem zu beheben, empfehlen wir, eine 5 cm dicke Füllung zwischen der Wand und dem Schrank anzubringen.

Basi con maniglia
Base units with handle

Basi con gola
Base units with groove

Colonne
Tall units

Pensili
Wall units

Elementi speciali
Special elements

Maniglie gole zoccoli
Handles grooves plinth

Illuminazione
Lighting

Accessori
Accessories

Componenti e meccanismi
Components e mechanism

CONSIGLI UTILI PER LA PROGETTAZIONE

Useful design tips
Conseils utiles pour la conception
Consejos útiles de diseño
Nützliche Gestaltungstipps

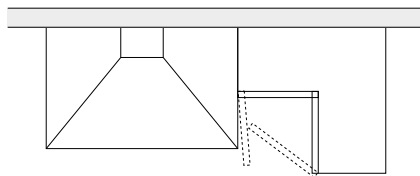

PENSILE AD ANGOLO

Quando la cappa viene accostata ad un pensile angolo le ante non si aprono impedendo l'accesso all'interno del pensile.

CORNER WALL UNIT

When the hood is placed next to a corner wall unit, the doors do not open, preventing access to the inside of the wall unit.

UNITÉ MURALE D'ANGLE

Lorsque la hotte est placée à côté d'une unité murale d'angle, les portes ne s'ouvrent pas, ce qui empêche l'accès à l'intérieur de l'unité murale.

MUEBLE ESQUINERO DE PARED

Cuando la campana se coloca junto a un mueble alto de esquina, las puertas no se abren, impidiendo el acceso al interior del mueble alto.

ECK-WANDSCHRANK

Wenn die Dunstabzugshaube neben einer Eckschrankwand aufgestellt wird, lassen sich die Türen nicht öffnen, so dass der Zugang zum Inneren der Schrankwand nicht möglich ist.

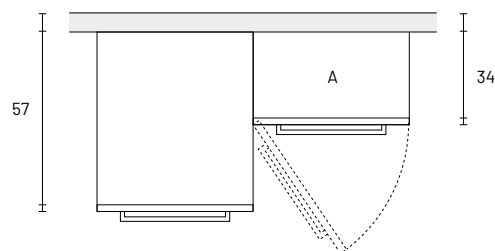

PENSILE AFFIANCATO AD UNA COLONNA

Quando un pensile viene affiancato ad una colonna, la maniglia non permette la corretta apertura dell'anta, rovinando la superficie del fianco della colonna. La soluzione è l'utilizzo di un riempitivo di 5 cm tra pensile e colonna.

WALL UNIT FLANKED BY A TALL UNIT

When a wall unit is placed side by side with a column, the handle does not allow the door to open properly, ruining the surface of the column side. The solution is the use of a 2-inch filler between the wall unit and column.

UNITÉ MURALE FLANQUÉE D'UNE COLONNE

Lorsqu'une armoire murale est placée à côté d'une armoire haute, la poignée ne permet pas à la porte de s'ouvrir correctement, ce qui abîme la surface du côté de l'armoire haute. La solution est d'utiliser un joint de 5 cm entre l'élément haut et l'élément bas.

MUEBLE ALTO FLANQUEADO POR UNA COLUMNA

Cuando se coloca un mueble alto junto a un mueble alto, el tirador no permite que la puerta se abra correctamente, estropeando la superficie del lateral del mueble alto. La solución es utilizar un relleno de 5 cm entre el mueble alto y el mueble alto.

OBERSCHRANK FLANKIERT VON EINER SÄULE

Wenn ein Oberschrank neben einem Hochschrank steht, lässt sich die Tür aufgrund des Griffs nicht richtig öffnen, wodurch die Oberfläche der Seite des Hochschanks beschädigt wird. Die Lösung besteht darin, eine 5 cm hohe Füllung zwischen Oberschrank und Hochschrank zu verwenden.

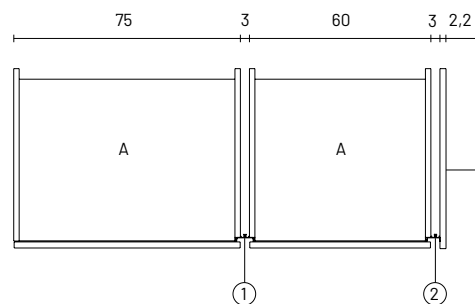

INGOMBRO GOLA VERTICALE PER COLONNA

VERTICAL GROOVE DIMENSION PER TALL UNIT

DIMENSION DE LA RAINURE VERTICALE PAR COLONNE

DIMENSIÓN DE LA RANURA VERTICAL POR COLUMNA

VERTIKALES RILLENMASS PRO SÄULE

1. Gola verticale intermedia | Vertical intermediate groove | Rainure intermédiaire verticale | Ranura intermedia vertical | Vertical intermediate groove
2. Gola verticale terminale | Vertical end groove | Rainure d'extrémité verticale | Ranura final vertical | Vertikale Endrille
3. Spalla finita 2 lati | 2-sided finished side panel | Panneau latéral finie des deux côtés | Lateral acabado por 2 lados | 2-seitig bearbeitete Aussenseiten

COMPONIBILITÀ

Composability
Composabilité
Composibilidad
Zusammensetzbarkeit

SISTEMI CON MANIGLIA

Handle systems
Systèmes de poignées
Sistemas de asas
Handgriff-Systeme

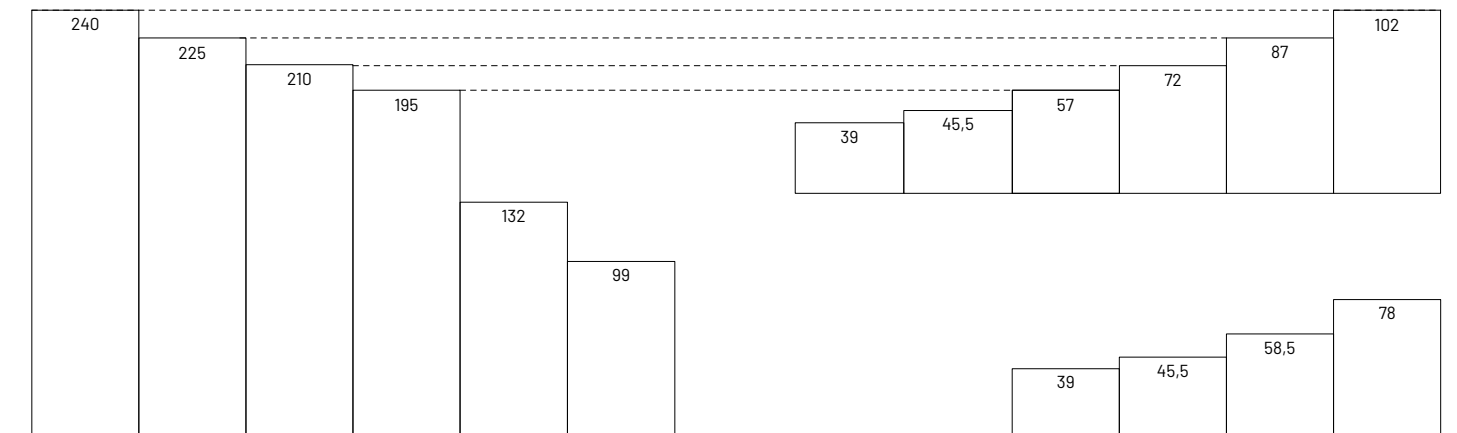

SISTEMI CON GOLA

Systems with groove
Systèmes de la gorge
Sistemas con gola
Kehlkopfsysteme

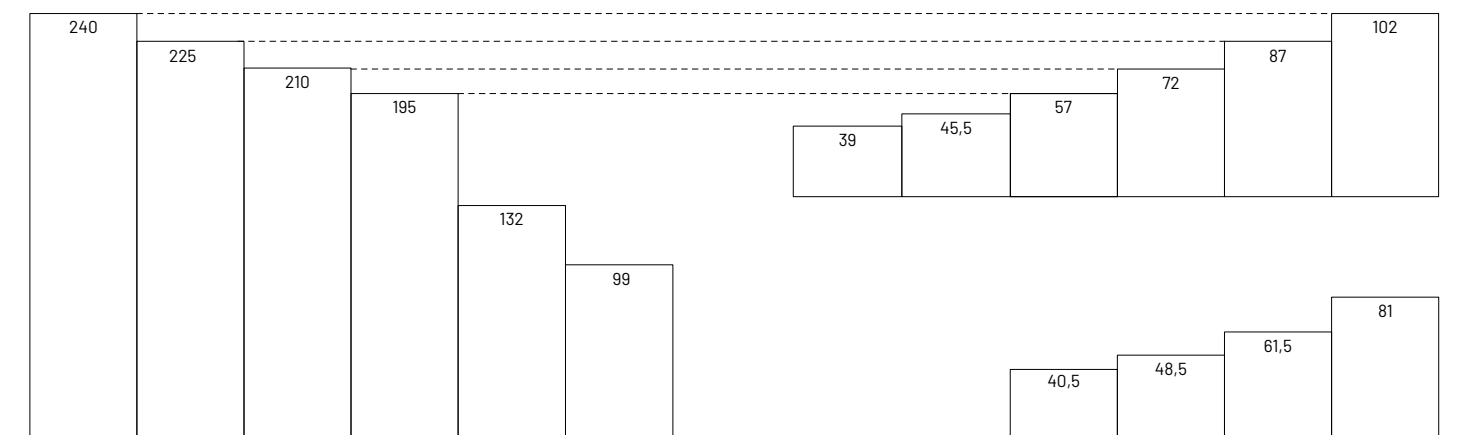

Basi con maniglia
Base units with handle

Basi con gola
Base units with groove

Colonne
Tall units

Pensili
Wall units

Elementi speciali
Special elements

Maniglie gole zoccoli
Handles grooves plinth

Illuminazione
Lighting

Accessori
Accessories

Componenti e meccanismi
Components e mechanism

MODULARITÀ BASI CON MANIGLIA

Base unit modularity with handle
 Modularité de l'unité de base avec poignée
 Modularidad de la unidad base con asa
 Modularer Unterschrank mit Griff

BASI CON MANIGLIA

Base units with handle
 Bases avec poignée
 Bases con tirador
 Unterschänke mit Griff

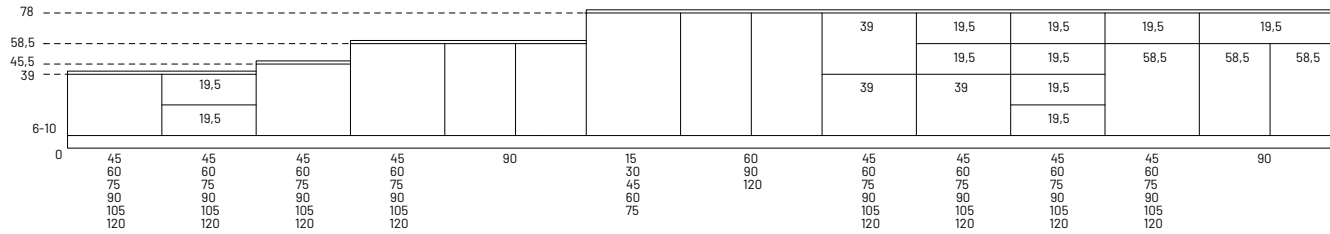

BASI PIANO COTTURA CON MANIGLIA

Hob base units with handle
 Socles de table de cuisson avec poignée
 Placas base con mango
 Kochfeldsockel mit Griff

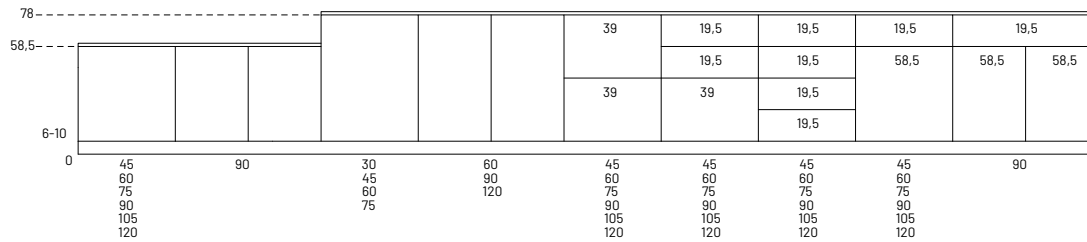

BASI LAVELLO CON MANIGLIA

Sink base units with handle
 Eléments bas d'évier avec poignée
 Mueble bajo fregadero con tirador
 Spülenunterschänke mit Griff

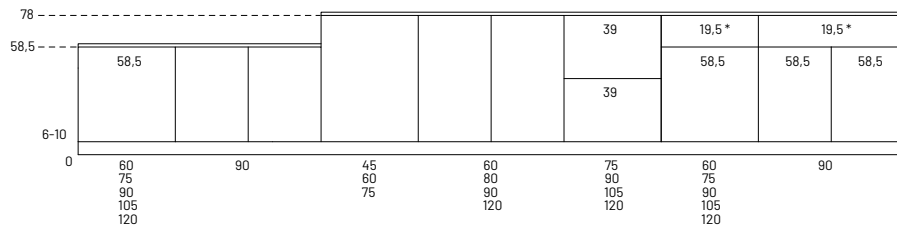

BASI FORNO

Oven base units
 Socles de four
 Bases de horno
 Backofenböden

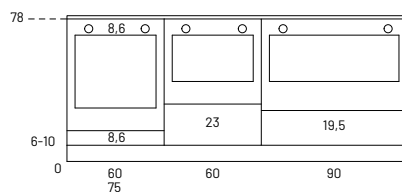

MODULARITÀ BASI CON GOLA

Modularity of bases with groove
 Modularité des bases avec rainure
 Modularidad de las bases con ranura
 Modularität der Sockel mit Rille

BASI CON GOLA

Base units with groove
 Bases avec rainure
 Bases con uñero
 Unterschränke mit Griffleiste

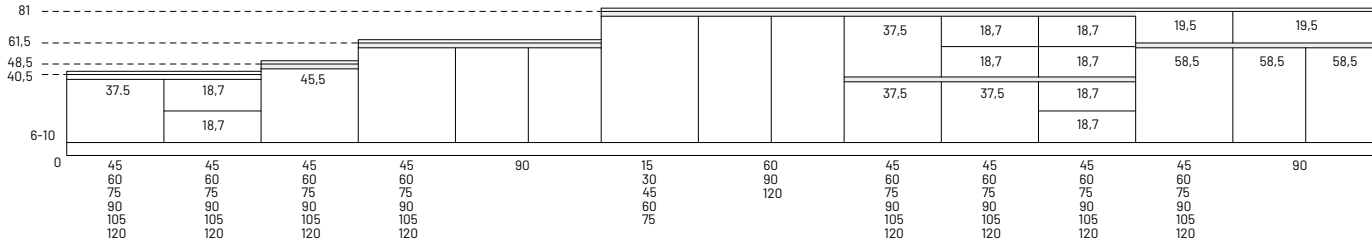

BASI PIANO COTTURA CON GOLA

Hob base units with groove
 Socles de fraise avec rainure
 Placas base con ranura
 Wälzfrässockel mit Rille

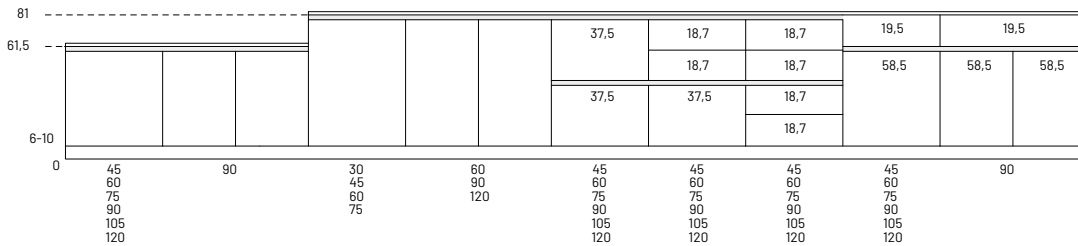

BASI LAVELLO CON GOLA

Sink base units with groove
 Eléments bas d'évier avec rainure
 Mueble bajo fregadero con ranura
 Spülenunterschränke mit Rinne

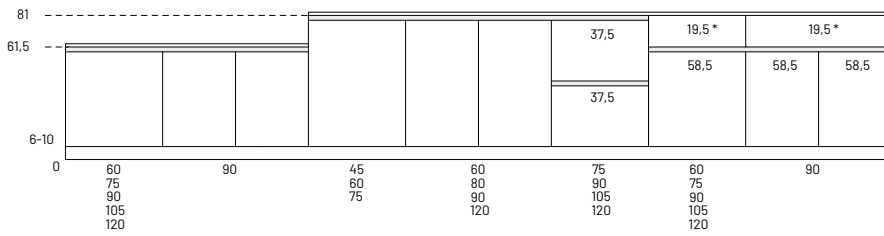

BASI FORNO CON GOLA

Oven base units with groove
 Socles de four avec gorge
 Bases de horno con gola
 Backofenböden mit Kehle

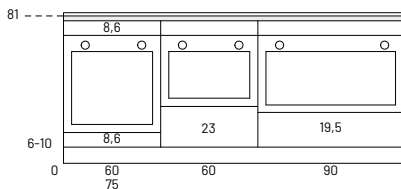

Basi con maniglia
 Base units with handle

Basi con gola
 Base units with groove

Colonne
 Tall units

Pensili
 Wall units

Elementi speciali
 Special elements

Maniglie gole zoccoli
 Handles grooves plinth

Illuminazione
 Lighting

Accessori
 Accessories

Componenti e meccanismi
 Components e mechanism

MODULARITÀ COLONNE

Tall units modularity
 Modularité des colonnes
 Modularidad de columnas
 Modularität der Säulen

COLONNE

Tall units
 Colonnes
 Columnas
 Hochschränke

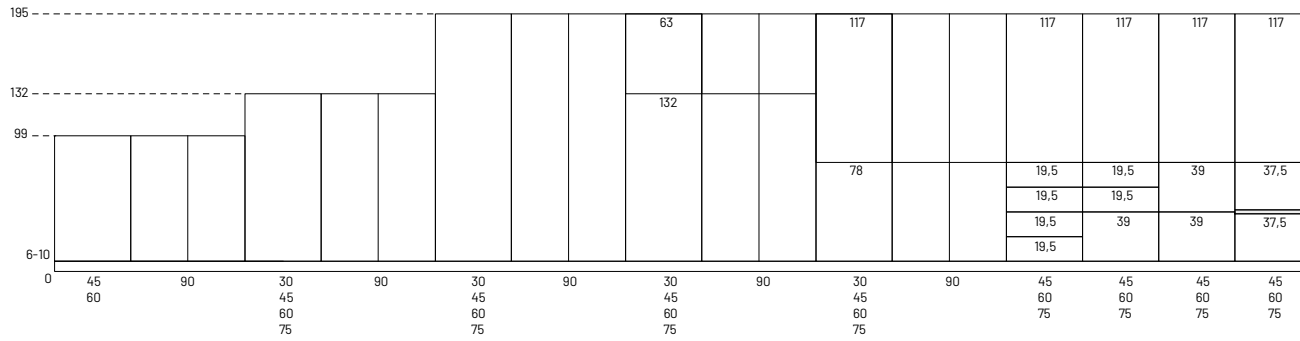

COLONNE

Tall units
 Colonnes
 Columnas
 Hochschränke

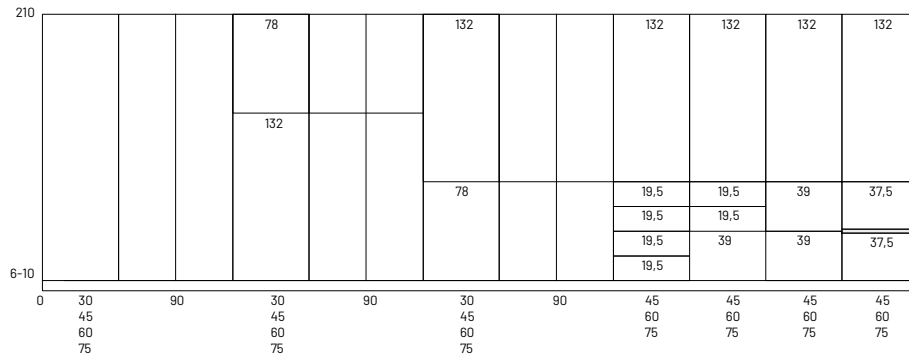

COLONNE

Tall units
 Colonnes
 Columnas
 Hochschränke

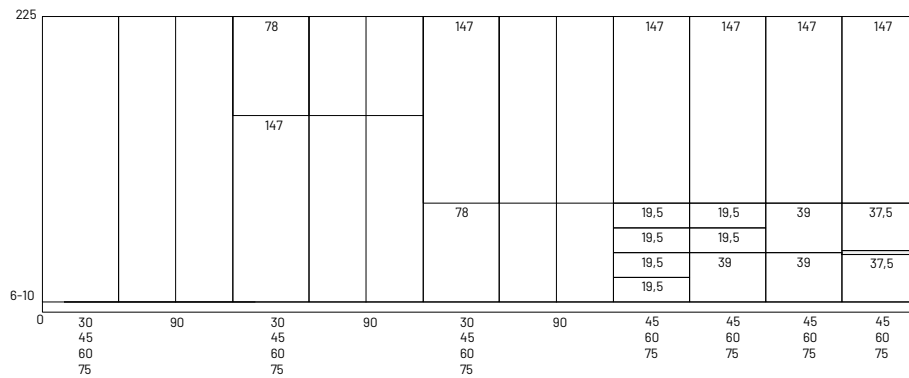

MODULARITÀ COLONNE

Tall units modularity
 Modularité des colonnes
 Modularidad de columnas
 Modularität der Säulen

COLONNE

Tall units
 Colonnes
 Columnas
 Hochschränke

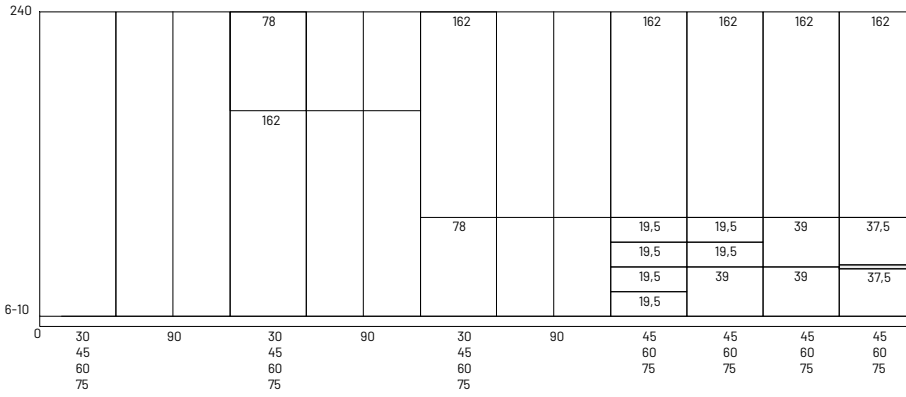

COLONNE FORNO

Oven tall units
 Colonnes four
 Columnas horno
 Backofen-Hochschränke

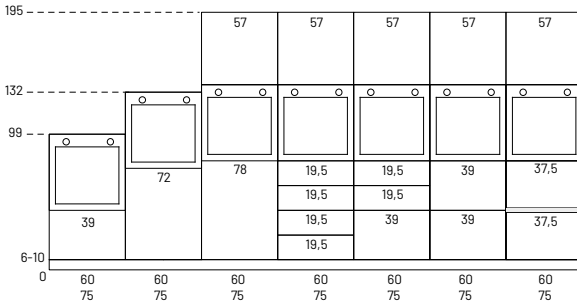

COLONNE FORNO

Oven tall units
 Colonnes four
 Columnas horno
 Backofen-Hochschränke

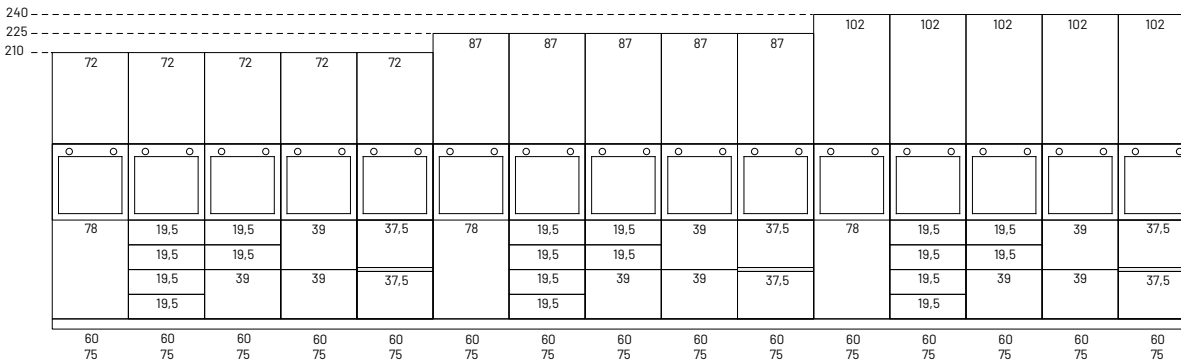

Basi con maniglia
 Base units with handle

Basi con gola
 Base units with groove

Colonne
 Tall units

Pensili
 Wall units

Elementi speciali
 Special elements

Maniglie gole zoccoli
 Handles grooves plinth

Illuminazione
 Lighting

Accessori
 Accessories

Componenti e meccanismi
 Components e mechanism

MODULARITÀ PENSILI

Modularity of wall units
 Modularité des unités murales
 Modularidad de los muebles altos
 Modularität der Oberschränke

PENSILI

Wall cabinets
 Modules suspendus
 Colgantes
 Hängeschränke

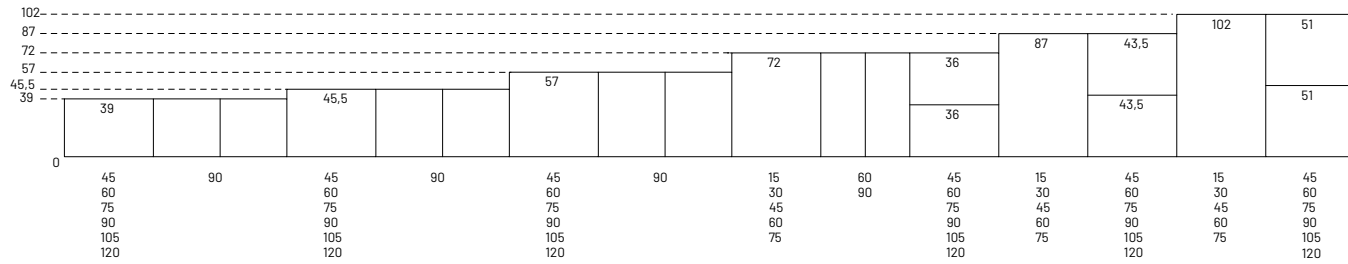

PENSILI SCOLAPIATTI

Dish drainer wall units
 Modules suspendus avec égouttoir à vaisselle
 Colgantes escurridores
 Hängeschränke mit Abtropfflächen

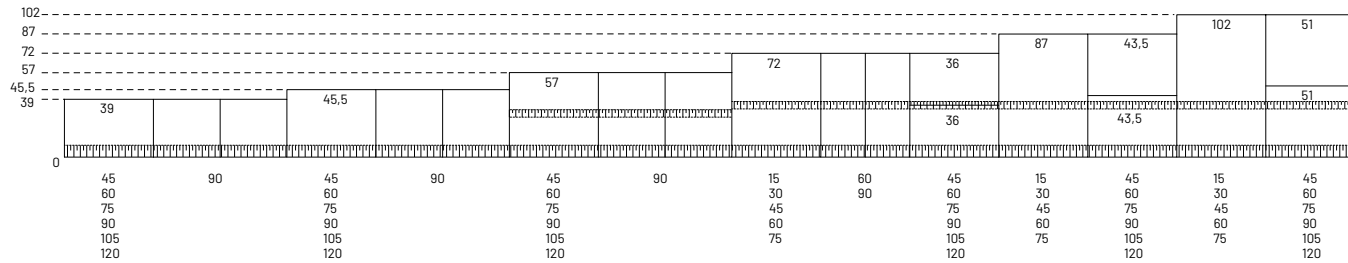

PENSILI CAPPA

Wall cabinets hood
 Modules suspendus hotte
 Colgantes con campana
 Hängeschränke Haube

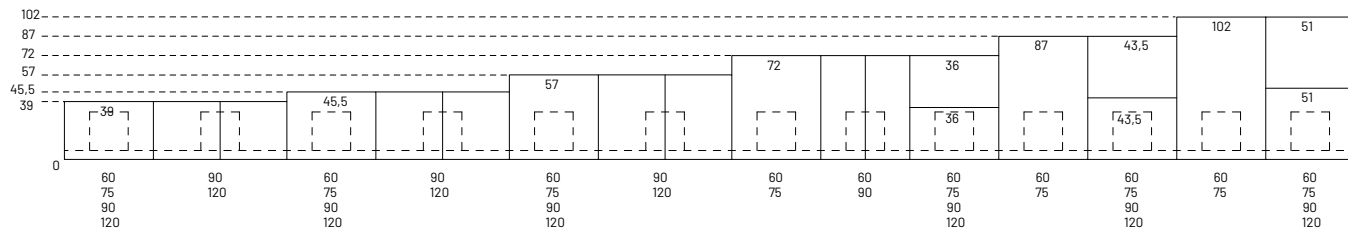

MODULARITÀ PENSILI COMPOSTI

Modularity of compound wall units
Modularité des unités murales composées
Modularidad de las unidades murales compuestas
Modularität der Verbundwandelemente

PENSILI COMPOSTI

Composite wall units
Modules suspendis compvés
Colgantes compuestos
Kombi-Hängeschränke

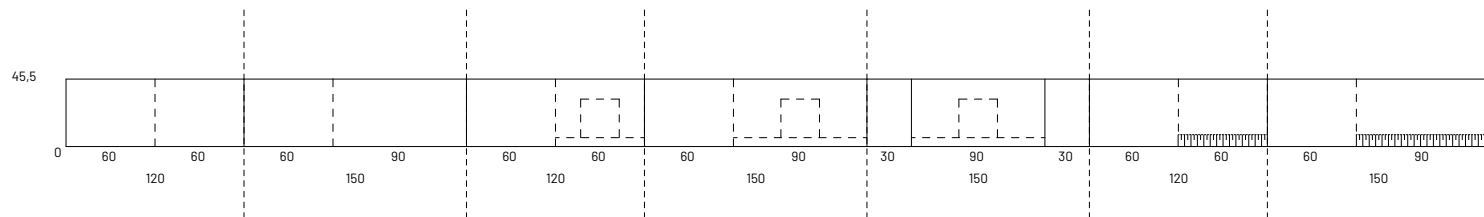

PENSILI COMPOSTI

Composite wall units
Modules suspendis compvés
Colgantes compuestos
Kombi-Hängeschränke

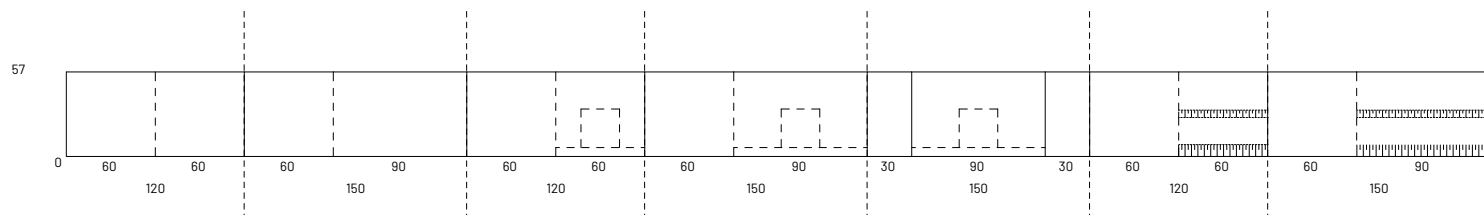

Basi con maniglia
Base units with handle

Basi con gola
Base units with groove

Colonne
Tall units

Pensili
Wall units

Elementi speciali
Special elements

Maniglie gole zoccoli
Handles grooves plinth

Illuminazione
Lighting

Accessori
Accessories

Componenti e meccanismi
Components e mechanism

MODULARITÀ VETRINA

Showcase modularity
Présenter la modularité
Mostrar modularidad
Modularität präsentieren

PENSILI VETRINA

Display cabinets
Vitrines
Vitrinas colgantes
Hängeschränke mit Glasstür

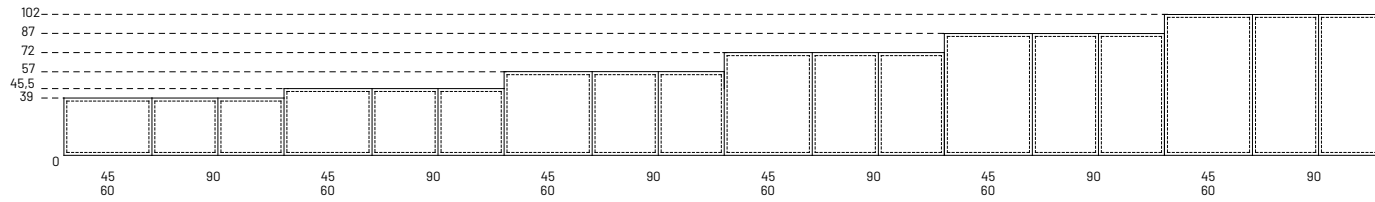

COLONNE VETRINA

Showcase tall units
Vitrine
Columnas vitrina
Glasstuer Hochschränke

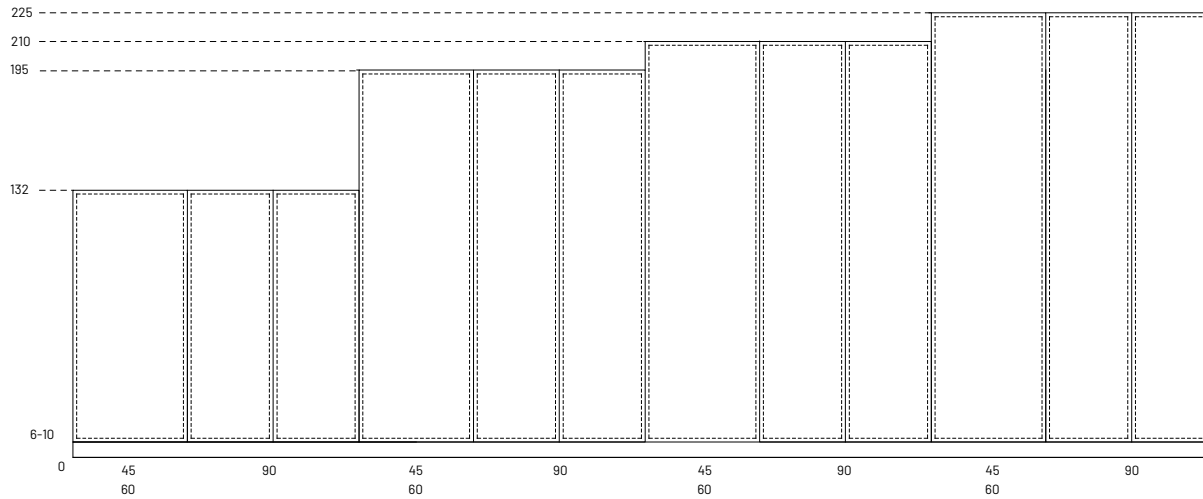

SEZIONI LATERALI BASI CON MANIGLIA

Lateral sections base units with handle
Sections latérales de la base avec poignée
Secciones laterales de la base con asa
Seitliche Fußteile mit Griff

PROFONDITÀ 34

Depth 34
Profondeur 34
Profundidad 34
Tiefe 34

BASE 1-2 ANTE

Base unit with 1-2 hinged doors
Unité de base 1-2 portes
Unidad base 1-2 puertas
Unterschrank 1-2 Türen

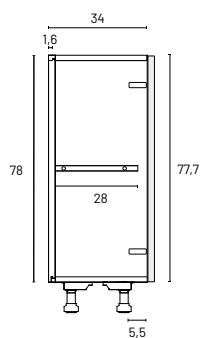

Basi con maniglia
Base units with handle

Basi con gola
Base units with groove

Colonne
Tall units

Pensili
Wall units

Elementi speciali
Special elements

Maniglie gole zoccoli
Handles grooves plinth

Illuminazione
Lighting

Accessori
Accessories

Componenti e meccanismi
Components e mechanism

SEZIONI LATERALI BASI CON MANIGLIA

Lateral sections base units with handle
 Sections latérales de la base avec poignée
 Secciones laterales de la base con asa
 Seitliche Fußteile mit Griff

PROFONDITÀ 57

Depth 57
 Profondeur 57
 Profundidad 57
 Tiefe 57

BASE 1-2 ANTE

Base unit with 1-2 hinged doors
 Unité de base 1-2 portes
 Unidad base 1-2 puertas
 Unterschrank 1-2 Türen

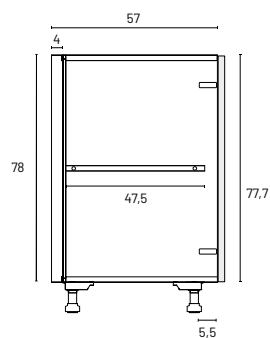

BASE ESTRAIBILE + 2 CASSETTI INTERNI

Base unit with pull-out deep drawer + 2 interior drawers
 Base coulissante + 2 tiroirs intérieurs
 Base extraible + 2 cajones interiores
 Ausziehbarer Boden + 2 Innenschubladen

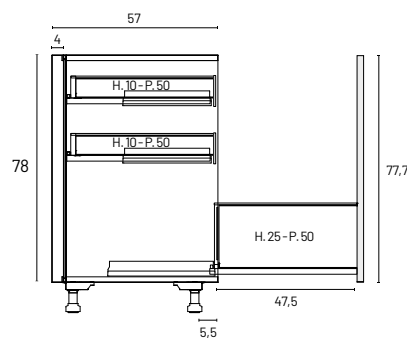

BASE 2 CESTONI

Base unit 2 deep drawers
 Base 2 paniers
 Base 2 cestas
 Unterschrank 2 Schubkasten

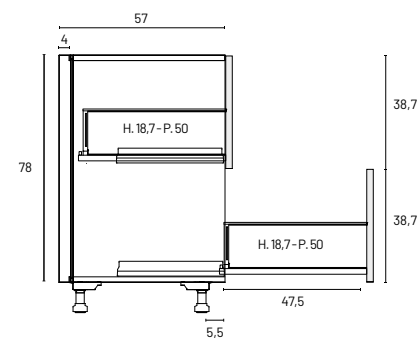

BASE 2 CASSETTI + 1 CESTONE

Base unit 2-drawers + 1 deep drawer
 Base 2 tiroirs + 1 panier
 Base 2 cajones + 1 cajón
 Unterschrank 2 Schubladen + 1 Schubkast

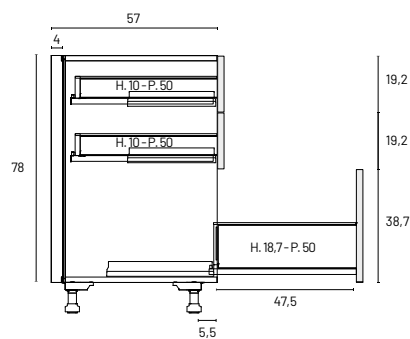

BASE LAVELLO 1-2 ANTE

Sink base unit with 1-2 hinged door
 Élément bas d'évier à 1 ou 2 portes
 Mueble bajo fregadero de 1-2 puertas
 1-2-türiger Spülenunterschrank

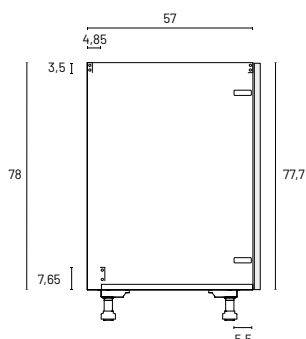

BASE LAVELLO 2 CESTONI

Sink base unit with 2 deep drawers
 Base sous evier 2 paniers
 Base fregadero de 2 cestas
 2-Schubkasten-Spülenunterschrank

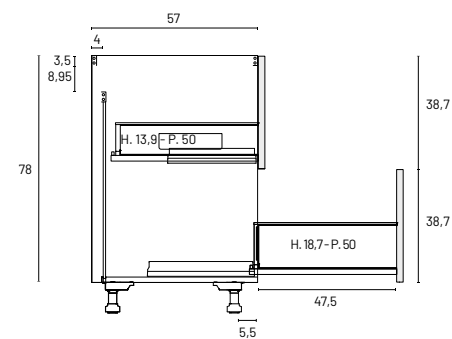

BASE COTTURA 2 ANTE

Hob base unit with 2 hinged doors
 Base cuisson 2 portes
 Base para hornear 2 puertas
 Kochfeldunterschrank 2 Türen

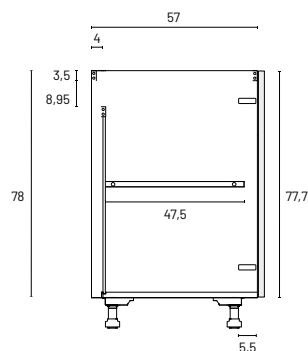

BASE COTTURA 2 CESTONI

Hob base unit with 2 deep drawers
 Base cuisson 2 paniers
 Base para hornear 2 cestas
 Kochfeldunterschrank 2 Schubkasten

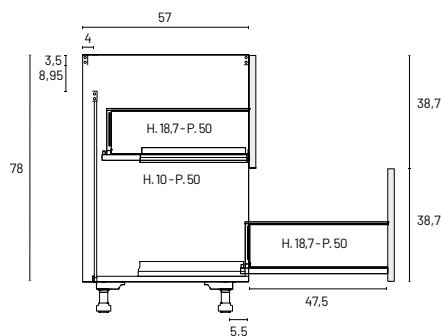

SEZIONI LATERALI BASI CON MANIGLIA

Lateral sections base units with handle
 Sections latérales de la base avec poignée
 Secciones laterales de la base con asa
 Seitliche Fußteile mit Griff

PROFONDITÀ 67

Depth 67
 Profondeur 67
 Profundidad 67
 Tiefe 67

BASE 1-2 ANTE

Base unit with 1-2 hinged doors
 Unité de base 1-2 portes
 Unidad base 1-2 puertas
 Unterschrank 1-2 Türen

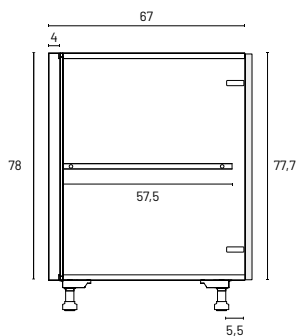

BASE ESTRAIBILE + 2 CASSETTI INTERNI

Base unit with pull-out deep drawer + 2 interior drawers
 Base coulissante + 2 tiroirs intérieurs
 Base extraíble + 2 cajones interiores
 Ausziehbarer Boden + 2 Innenschubladen

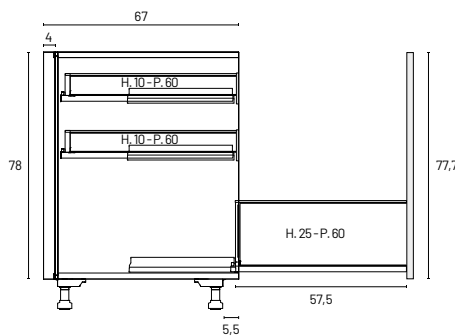

BASE 2 CESTONI

Base unit 2 deep drawers
 Base 2 paniers
 Base 2 cestas
 Unterschrank 2 Schubkasten

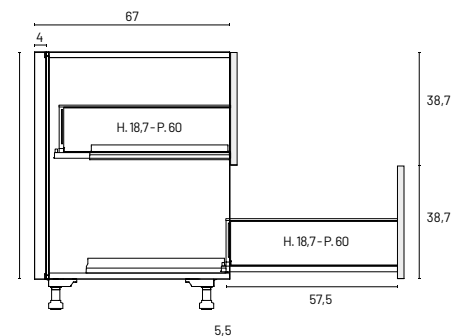

BASE 2 CASSETTI + 1 CESTONE

Base unit 2-drawers + 1 deep drawer
 Base 2 tiroirs + 1 panier
 Base 2 cajones + 1 cajón
 Unterschrank 2 Schubladen + 1 Schubkast

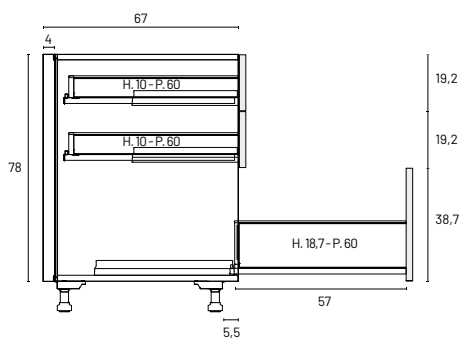

BASE LAVELLO 1-2 ANTE

Sink base unit with 1-2 hinged door
 Élément bas d'évier à 1 ou 2 portes
 Mueble bajo fregadero de 1-2 puertas
 1-2-türiger Spülenunterschrank

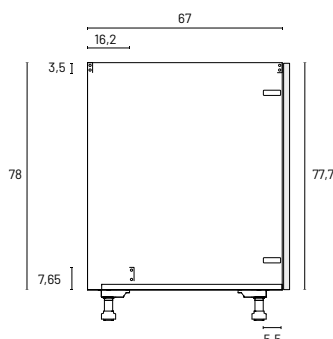

BASE LAVELLO 2 CESTONI

Sink base unit with 2 deep drawers
 Base sous evier 2 paniers
 Base fregadero de 2 cestas
 2-Schubkasten-Spülenunterschrank

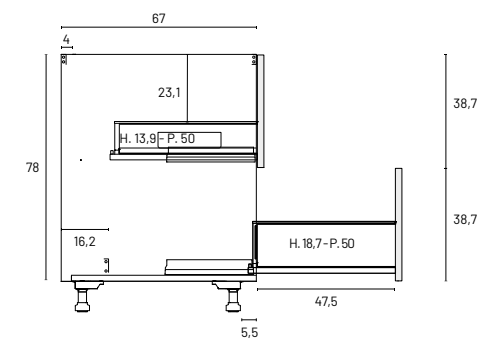

BASE COTTURA 1-2 ANTE

Hob base unit 1-2 doors
 Unité de cuisson 1-2 portes
 Placa de cocción 1-2 puertas
 Kochfeldinheit 1-2 Türen

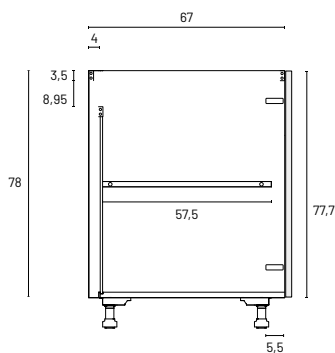

BASE COTTURA 2 CESTONI

Hob base unit with 2 deep drawers
 Base cuisson 2 paniers
 Base para hornear 2 cestas
 Kochfeldunterschrank 2 Schubkasten

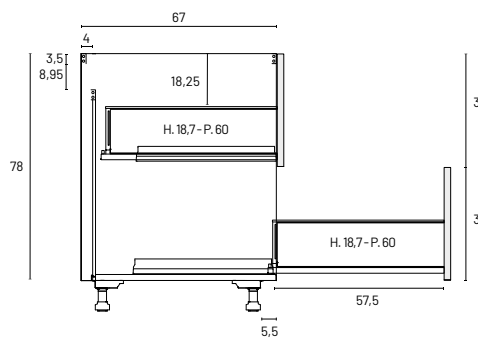

Basi con maniglia
 Base units with handle

Basi con gola
 Base units with groove

Colonne
 Tall units

Pensili
 Wall units

Elementi speciali
 Special elements

Maniglie gole zoccoli
 Handles grooves plinth

Illuminazione
 Lighting

Accessori
 Accessories

Componenti e meccanismi
 Components e mechanism

SEZIONI LATERALI BASI CON GOLA

Lateral sections base units with groove
Sections latérales de la base avec rainure
Secciones de base laterales con ranura
Seitliche Bodenteile mit Rille

PROFONDITÀ 34

Depth 34
Profondeur 34
Profundidad 34
Tiefe 34

BASE 1-2 ANTE

Base unit with 1-2 hinged doors
Unité de base 1-2 portes
Unidad base 1-2 puertas
Unterschrank 1-2 Türen

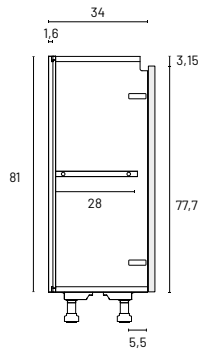

SEZIONI LATERALI BASI CON GOLA

Lateral sections base units with groove
 Sections latérales de la base avec rainure
 Secciones de base laterales con ranura
 Seitliche Bodenteile mit Rille

PROFONDITÀ 57

Depth 57
 Profondeur 57
 Profundidad 57
 Tiefe 57

BASE 1-2 ANTE

Base unit with 1-2 hinged doors
 Unité de base 1-2 portes
 Unidad base 1-2 puertas
 Unterschrank 1-2 Türen

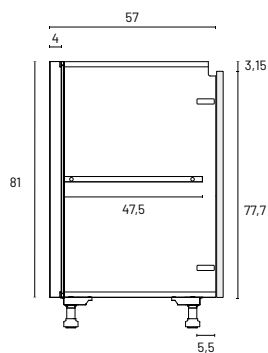

BASE ESTRAIBILE + 2 CASSETTI INTERNI

Base unit with pull-out deep drawer + 2 interior drawers
 Base coulissante + 2 tiroirs intérieurs
 Base extraíble + 2 cajones interiores
 Ausziehbarer Boden + 2 Innenschubladen

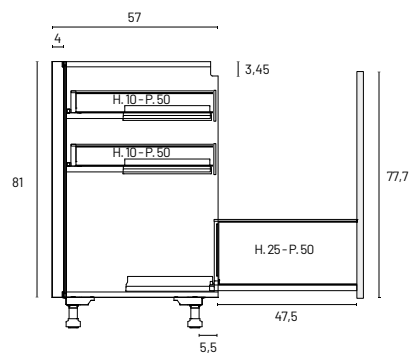

BASE LAVELLO 1-2 ANTE

Sink base unit with 1-2 hinged door
 Élément bas d'évier à 1 ou 2 portes
 Mueble bajo fregadero de 1-2 puertas
 1-2-türiger Spülenunterschrank

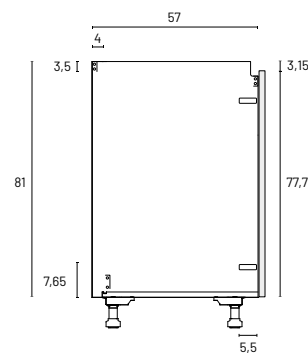

BASE COTTURA 1-2 ANTE

Hob base unit 1-2 doors
 Unité de cuisson 1-2 portes
 Placa de cocción 1-2 puertas
 Kochfeldeinheit 1-2 Türen

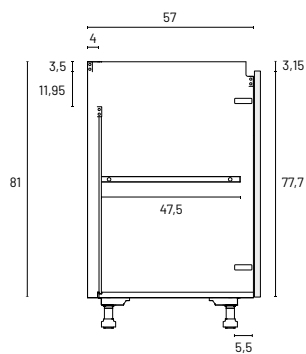

Bas con maniglia
 Base units with handle

Bas con gola
 Base units with groove

Colonne
 Tall units

Pensili
 Wall units

Elementi speciali
 Special elements

Maniglie gole zoccoli
 Handles grooves plinth

Illuminazione
 Lighting

Accessori
 Accessories

Componenti e meccanismi
 Components e mechanism

SEZIONI LATERALI BASI CON GOLA

Lateral sections base units with groove
Sections latérales de la base avec rainure
Secciones de base laterales con ranura
Seitliche Bodenteile mit Rille

PROFONDITÀ 67

Depth 67
Profondeur 67
Profundidad 67
Tiefe 67

BASE 1-2 ANTE

Base unit with 1-2 hinged doors
Unité de base 1-2 portes
Unidad base 1-2 puertas
Unterschrank 1-2 Türen

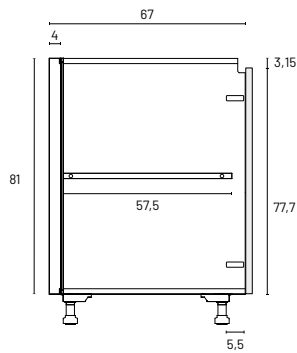

BASE ESTRAIBILE + 2 CASSETTI INTERNI

Base unit with pull-out deep drawer + 2 interior drawers
Base coulissante + 2 tiroirs intérieurs
Base extraible + 2 cajones interiores
Ausziehbarer Boden + 2 Innenschubladen

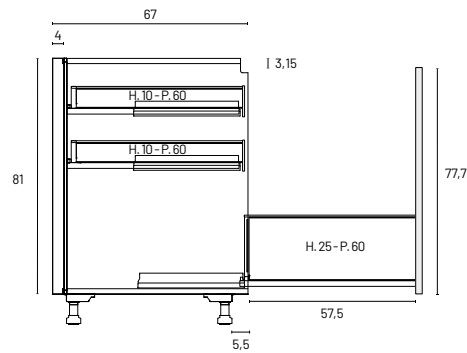

BASE LAVELLO 1-2 ANTE

Sink base unit with 1-2 hinged door
Élément bas d'évier à 1 ou 2 portes
Mueble bajo fregadero de 1-2 puertas
1-2-türiger Spülenunterschrank

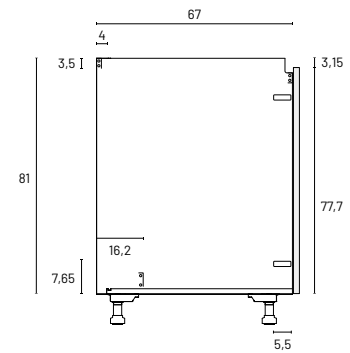

BASE COTTURA 1-2 ANTE

Hob base unit 1-2 doors
Unité de cuisson 1-2 portes
Placa de cocción 1-2 puertas
Kochfeldeinheit 1-2 Türen

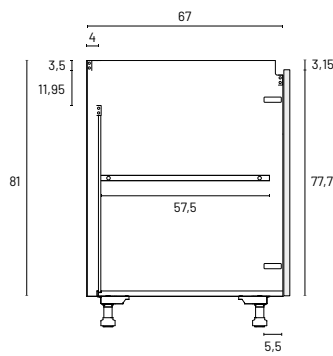

SEZIONI LATERALI BASI CON GOLA INTERMEDIA

PROFONDITÀ 57

Base units side sections with intermediate groove
 Sections latérales de la base avec rainure intermédiaire
 Secciones de base laterales con ranura intermedia
 Seitliche Bodenprofile mit Zwischenrinne

Depth 57
 Profondeur 57
 Profundidad 57
 Tiefe 57

BASE 1 CASSETTO + 2 ANTE

Base unit 1 drawer + 2 hinged doors
 Base 1 tiroir + 2 portes
 Base 1 cajón + 2 puertas
 Unterschrank 1 Schublade + 2 Türen

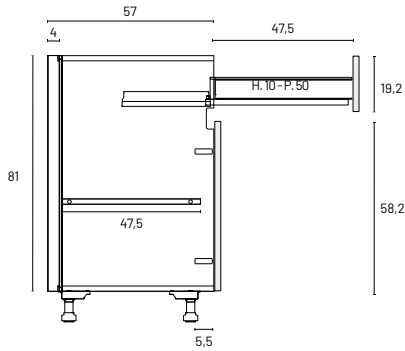

BASE 1 CASSETTO + 1 ESTRAIBILE + 1 CASSETTO INTERNO

Base unit 1 drawer + 1 pull-out deep drawer + 1 interior drawer
 Élément bas 1 tiroir + 1 coulissant + 1 tiroir à l'anglaise
 Mueble bajo 1 cajón + 1 extraíble + 1 cajón interior
 Unterschrank 1 Schublade + 1 Auszug + 1 Innenschublade

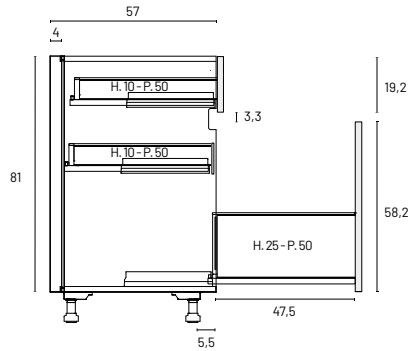

BASE 4 CASSETTI

Base unit 4-drawer
 Base 4 tiroirs
 Base de 4 cajones
 4-Schubladen-Unterschrank

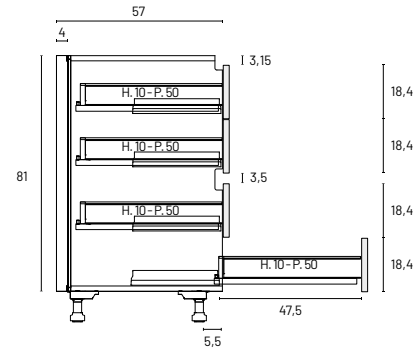

BASE 2 CASSETTI + 1 CESTONE

Base unit 2-drawers + 1 deep drawer
 Base 2 tiroirs + 1 panier
 Base 2 cajones + 1 cajón
 Unterschrank 2 Schubladen + 1 Schubkast

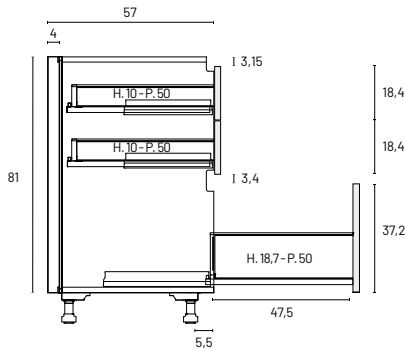

BASE LAVELLO 2 CESTONI

Sink base unit with 2 deep drawers
 Base sous evier 2 paniers
 Base fregadero de 2 cestas
 2-Schubkasten-Spülenunterschrank

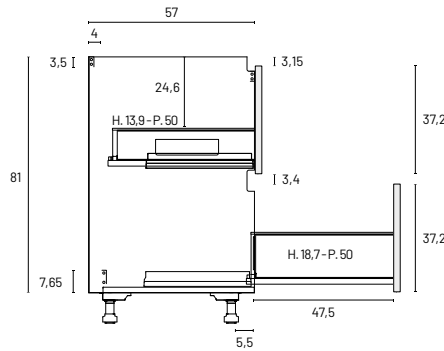

BASE COTTURA 2 CESTONI

Hob base unit with 2 deep drawers
 Base cuisson 2 paniers
 Base para hornear 2 cestas
 Kochfeldunterschrank 2 Schubkasten

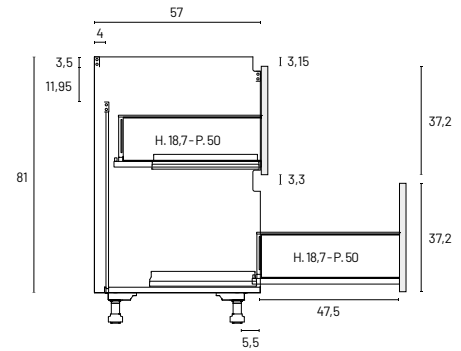

Basi con maniglia
 Base units with handle

Basi con gola
 Base units with groove

Colonne
 Tall units

Pensili
 Wall units

Elementi speciali
 Special elements

Maniglie gole zoccoli
 Handles grooves plinth

Illuminazione
 Lighting

Accessori
 Accessories

Componenti e meccanismi
 Components e mechanism

SEZIONI LATERALI BASI CON GOLA INTERMEDIA

Base units side sections with intermediate groove
 Sections latérales de la base avec rainure intermédiaire
 Secciones de base laterales con ranura intermedia
 Seitliche Bodenprofile mit Zwischenrinne

PROFONDITÀ 67

Depth 67
 Profondeur 67
 Profundidad 67
 Tiefe 67

BASE 1 CASSETTO + 2 ANTE

Base unit 1 drawer + 2 hinged doors
 Base 1 tiroir + 2 portes
 Base 1 cajón + 2 puertas
 Unterschrank 1 Schublade + 2 Türen

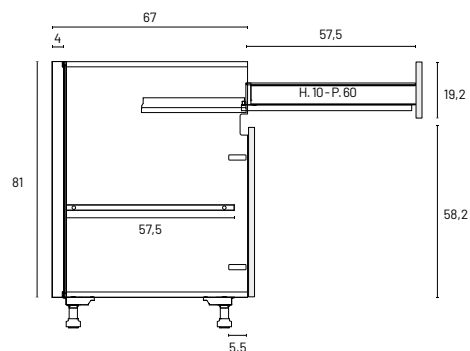

BASE 1 CASSETTO + 1 ESTRAIBILE + 1 CASSETTO INTERNO

Base unit 1 drawer + 1 pull-out deep drawer + 1 interior drawer
 Élément bas 1 tiroir + 1 coulissant + 1 tiroir à l'anglaise
 Mueble bajo 1 cajón + 1 extraíble + 1 cajón interior
 Unterschrank 1 Schublade + 1 Auszug + 1 Innenschublade

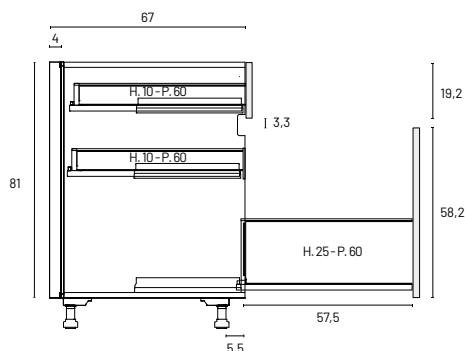

BASE 4 CASSETTI

Base unit 4-drawer
 Base 4 tiroirs
 Base de 4 cajones
 4-Schubladen-Unterschrank

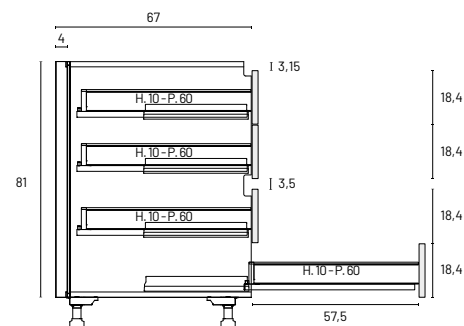

BASE 2 CASSETTI + 1 CESTONE

Base unit 2-drawers + 1 deep drawer
 Base 2 tiroirs + 1 panier
 Base 2 cajones + 1 cajón
 Unterschrank 2 Schubladen + 1 Schubkast

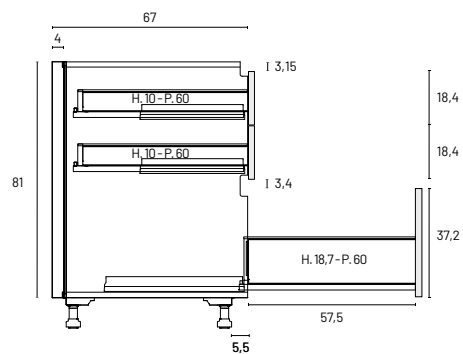

BASE LAVELLO 2 CESTONI

Sink base unit with 2 deep drawers
 Base sous evier 2 paniers
 Base fregadero de 2 cestas
 2-Schubkasten-Spülenunterschrank

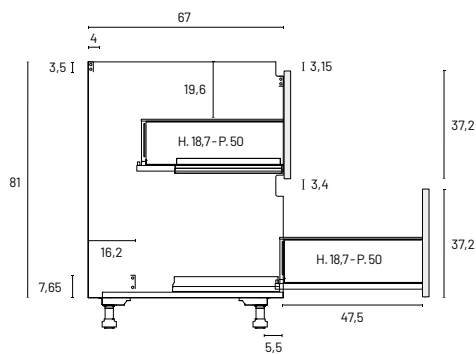

BASE COTTURA 2 CESTONI

Hob base unit with 2 deep drawers
 Base cuisson 2 paniers
 Base para hornear 2 cestas
 Kochfeldunterschrank 2 Schubkasten

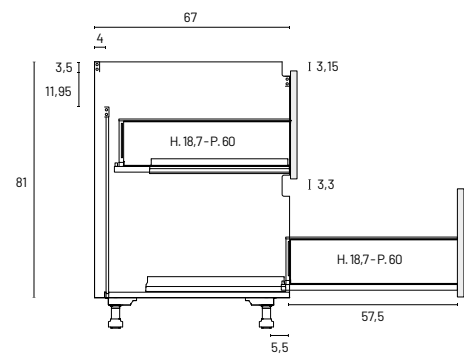

SEZIONI LATERALI PENSILI

Hanging side sections
 Sections latérales suspendues
 Secciones laterales colgantes
 Hängende Seitenteile

PROFONDITÀ 34

Depth 34
 Profondeur 34
 Profundidad 34
 Tiefe 34

PENSILE BATTENTE H. 39/45,5

Hinged wall unit H. 39/45.5
 Élément mural à charnières H. 39/45,5
 Mueble alto abatible H. 39/45,5
 Klappbarer Oberschrank H. 39/45,5

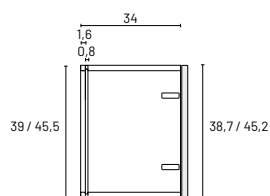

PENSILE BATTENTE H. 57/72

Hinged wall unit H. 57/72
 Unité murale à charnières H. 57/72
 Mueble alto abatible H. 57/72
 Klappbarer Oberschrank H. 57/72

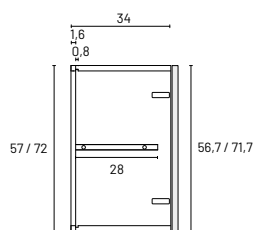

PENSILE BATTENTE H. 87/102

Hinged wall unit H. 87/102
 Unité murale à charnières H. 87/102
 Módulo mural abatible H. 87/102
 Klappbarer Oberschrank H. 87/102

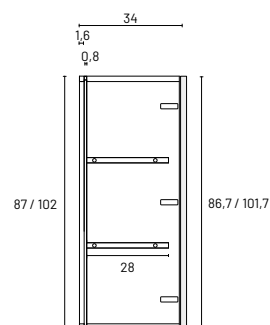

PENSILE VASISTAS H. 39

H. 39 vasistas wall unit
 H. 39 vasistas wall unit
 H. 39 vasistas mueble alto
 H. 39 vasistas Oberschrank

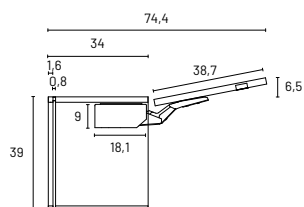

PENSILE VASISTAS H. 45,5

H. 45,5 vasistas wall unit
 H. 45,5 unité murale vasistas
 H. 45,5 vasistas mueble alto
 H. 45,5 vasistas Schrankwand

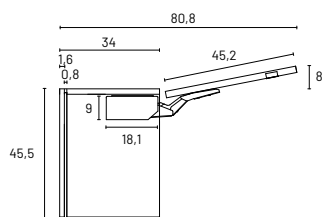

PENSILE VASISTAS H. 57

H. 57 vasistas wall unit
 H. 57 vasistas wall unit
 H. 57 vasistas mueble alto
 H. 57 vasistas Oberschrank

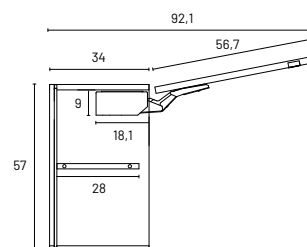

Basi con maniglia
 Base units with handle

Basi con gola
 Base units with groove

Colonne
 Tall units

Pensili
 Wall units

Elementi speciali
 Special elements

Maniglie gole zoccoli
 Handles grooves plinth

Illuminazione
 Lighting

Accessori
 Accessories

Componenti e meccanismi
 Components e mechanism

SEZIONI LATERALI PENSILI

Hanging side sections
Sections latérales suspendues
Secciones laterales colgantes
Hängende Seitenteile

PROFONDITÀ 34

Depth 34
Profondeur 34
Profundidad 34
Tiefe 34

PENSILE BASCULANTE H. 72

Overhead cabinet H. 72
Armoire suspendue H. 72
Armario superior H. 72
Hängeschrank H. 72

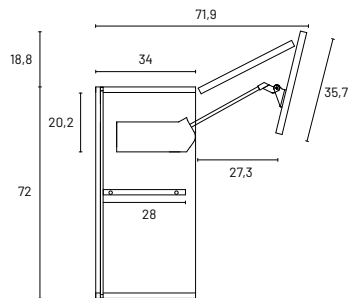

PENSILE BASCULANTE H. 87

Overhead cabinet H. 87
Armoire suspendue H. 87
Armario superior H. 87
Hängeschrank H. 87

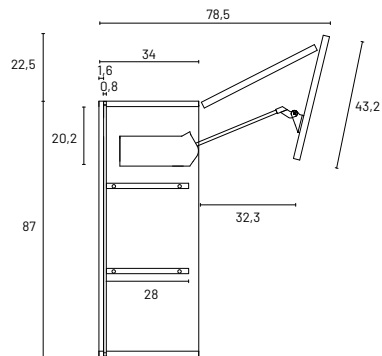

PENSILE BASCULANTE H. 102

Overhead cabinet H. 102
Armoire suspendue H. 102
Armario superior H. 102
Hängeschrank H. 102

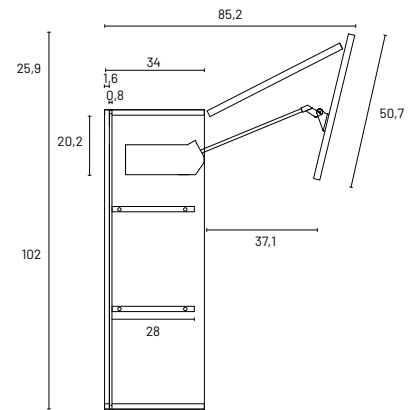

PENSILE SALISCENDI H. 57

Pendant wall unit H. 57
Unité murale suspendue H. 57
Mueble colgante H. 57
Hängewandschrank H. 57

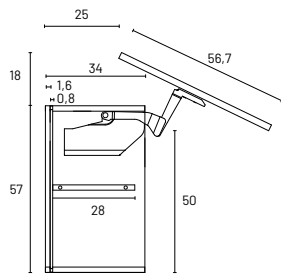

TIPOLOGIE ANTA LAVASTOVIGLIE

Dishwasher door types
Types de portes de lave-vaisselle
Tipos de puertas de lavavajillas
Türtypen für Geschirrspüler

ANTA LAVASTOVIGLIE CON GOLA

Dishwasher door with groove
Porte de lave-vaisselle avec rainure
Puerta de lavavajillas con ranura
Spülmaschinentür mit Rille

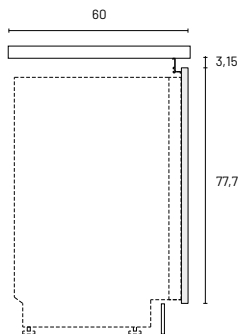

ANTA LAVASTOVIGLIE CON GOLA INTERMEDIA

Dishwasher door with intermediate groove
Porte du lave-vaisselle avec rainure intermédiaire
Puerta de lavavajillas con ranura intermedia
Spülmaschinentür mit Zwischenrille

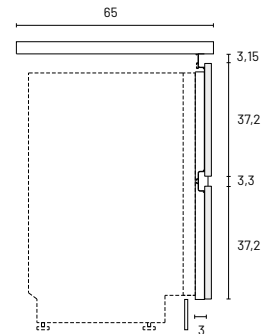

ANTA LAVASTOVIGLIE CON GOLA INTERMEDIA SUPERIORE

Dishwasher door with upper intermediate groove
Porte du lave-vaisselle avec rainure intermédiaire supérieure
Puerta de lavavajillas con ranura intermedia superior
Spülmaschinentür mit oberer Zwischenrille

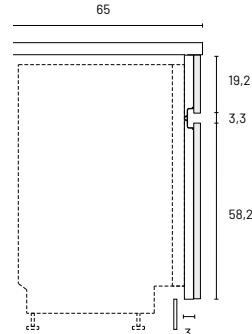

Per tutte le tipologie di anta lavastoviglie è necessario uno zoccolo H 10 per permettere la rotazione dell'anta. | For all types of dishwasher door, an H 10 plinth is required to allow the door to rotate. | Pour tous les types de portes de lave-vaisselle, un socle H 10 est nécessaire pour permettre à la porte de tourner. | Para todos los tipos de puerta de lavavajillas, se requiere un zócalo H 10 para permitir la rotación de la puerta. | Für alle Arten von Geschirrspülertüren ist ein Sockel H 10 erforderlich, damit die Tür gedreht werden kann.

FRONTALINO FISSO PER ANTA CON MANIGLIA

Fixed sash faceplate with handle
Façade de porte fixe avec poignée
Frente de puerta fijo con tirador
Feste Türfront mit Griff

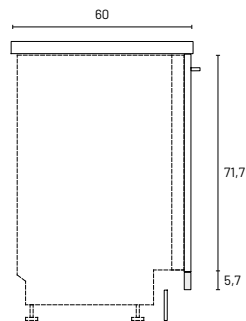

FRONTALINO FISSO PER ANTA CON GOLA

Fixed sash faceplate with groove
Gâche fixe pour porte avec rainure
Cerradero fijo para puerta con ranura
Festes SchlieBblech für Tür mit Nut

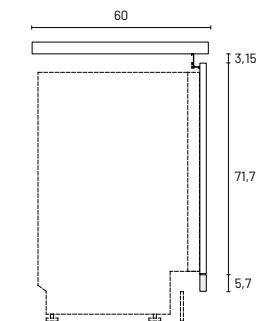

Nel caso di lavastoviglie non 'sliding doors' è previsto un tamponamento fisso. | In the case of dishwashers that are not 'sliding doors', a fixed buffer is provided. | Dans le cas des lave-vaisselle qui ne sont pas des "portes coulissantes", un tampon fixe est prévu. | En el caso de los lavavajillas que no son de "puertas correderas", se prevé un tope fijo. | Bei Geschirrspülern, die keine "Schiebetüren" sind, ist ein fester Puffer vorgesehen.

SCANSO ZOCCOLO

Scanning the plinth
Scanner le socle
Escaneado del zócalo
Scannen des Sockels

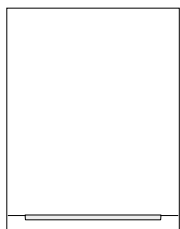

Nel caso di lavastoviglie integrata sarà necessario realizzare uno scanso nello zoccolo per permettere la corretta apertura dell'elettrodomestico. | In the case of an integrated dishwasher, it will be necessary to make a recess in the baseboard to allow the appliance to open properly. | Dans le cas d'un lave-vaisselle intégré, il sera nécessaire de faire un renfoncement dans la plinthe pour permettre à l'appareil de s'ouvrir correctement. | En el caso de un lavavajillas integrado, será necesario hacer un rebaje en el zócalo para permitir que el aparato se abra correctamente. | Bei einem integrierten Geschirrspüler muss eine Aussparung in der Sockelleiste angebracht werden, damit sich das Gerät ordnungsgemäß öffnen kann.

Basi con maniglia
Base units with handle

Basi con gola
Base units with groove

Colonne
Tall units

Pensili
Wall units

Elementi speciali
Special elements

Maniglie gole zoccoli
Handles grooves plinth

Illuminazione
Lighting

Accessori
Accessories

Componenti e meccanismi
Components e mechanism

LAVORAZIONI FUORI MISURA SU MOBILI DI SERIE

Out-of-order work on standard furniture
Travaux hors commande sur du mobilier standard
Trabajos fuera de pedido en mobiliario estándar
Außerplanmäßige Arbeiten an Standardmöbeln

MAGGIORAZIONI (PUNTI) ENHANCEMENTS (POINTS) SUPPLÉMENTS (POINTS) RECARGOS (PUNTOS) AUFPREISEN (PUNKTE)	BASI BASE UNITS BASES BASES BASE UNITS	PENSILI WALL CABINETS MODULES SUSPENDUS COLGANTES WALL CABINETS	COLONNE TALL UNITS COLONNES COLUMNAS TALL UNITS
RIDUZIONI IN ALTEZZA For reductions in height Pour les réductions de hauteur Para reducciones de altura Für Höhenkürzungen	83	83	83
RIDUZIONI IN LARGHEZZA For reductions in width Pour les réductions de largeur Para reducciones de anchura Für Breitenreduzierungen	98	98	130
RIDUZIONI IN PROFONDITÀ For reductions in depth Pour des réductions importantes Para reducciones profundas Für tiefe Senkungen	110	110	140
RIDUZIONI IN 2 DIMENSIONI For reductions in 2 dimensions Pour les réductions en 2 dimensions Para reducciones en 2 dimensiones Für Kürzungen in 2 Dimensionen	142	149	161
RIDUZIONI IN TUTTE LE DIMENSIONI For reductions in all sizes Pour des réductions de toutes tailles Para reducciones de todos los tamaños Für Ermäßigungen in allen Größen	209	215	246
SCANSO SCOCCA To scan the shell D'ailleurs Por cierto Übrigens	160	160	240
SCANSO SU 1 FIANCO PER INSERIMENTO PIANO COTTURA For scanning on 1 side for hob insertion Pour un balayage unilatéral pour l'insertion d'une plaque de cuisson Para la exploración de 1 cara para la inserción de fresas Für 1-seitigen Scan zum Einsetzen von Kochfeldern	38	-	-
RIDUZIONE LARGHEZZA CASSETTO/CESTONE For drawer/basket width reduction Pour la réduction de la largeur du tiroir/de la corbeille Para reducir la anchura del cajón/cesta Zur Reduzierung der Breite von Schubladen/Körben	35	-	35
BASI SOPPESE SOLO P. 57 For suspended bases only P. 57 Pour les bases suspendues uniquement P. 57 Sólo para bases suspendidas P. 57 Nur für hängende Sockel S. 57	48	-	-

LAVORAZIONI FUORI MISURA SU MOBILI DI SERIE

Out-of-order work on standard furniture
Travaux hors commande sur du mobilier standard
Trabajos fuera de pedido en mobiliario estándar
Außerplanmäßige Arbeiten an Standardmöbeln

MAGGIORAZIONI (PUNTI) ENHANCEMENTS (POINTS) SUPPLÉMENTS (POINTS) RECARGOS (PUNTOS) AUFPREISEN (PUNKTE)	BASI BASE UNITS BASES BASES BASE UNITS	PENSILI WALL CABINETS MODULES SUSPENDUS COLGANTES WALL CABINETS	COLONNE TALL UNITS COLONNES COLUMNS TALL UNITS
ESECUZIONE FORO PER TUBO CAPPA For execution hole for hood tube Pour l'exécution du trou du tube de la hotte Para la ejecución del orificio del tubo de la campana Für die Ausführung von Haubenrohlöchern	-	21	-
FRESATA LUCE CLIENTE For milled customer light Pour le fraisage de la lumière du client Para fresar la luz del cliente Zum Fräsen von Kundenlicht	-	95	-
MOBILE SMONTATO For disassembled cabinet Pour les meubles démontés Para muebles desmontados Für demontierte Möbel	30	30	70
I COSTI PER I CASI NON INDICATI DEVONO ESSERE PREVENTIVAMENTE CONCORDATI CON L'AZIENDA Costs for cases not mentioned must be agreed upon in advance with the company Les coûts pour les cas non mentionnés doivent être convenus à l'avance avec l'entreprise Los costes de los casos no mencionados deben acordarse previamente con la empresa Die Kosten für nicht genannte Fälle müssen im Voraus mit dem Unternehmen vereinbart werden			
NON POSSONO ESSERE MODIFICATI MOBILI CON ATTREZZATURE INTERNE Furniture with interior fittings may not be modified Les meubles avec aménagement intérieur ne peuvent pas être modifiés El mobiliario interior no puede modificarse Möbel mit Innenausstattung dürfen nicht verändert werden			
CONTRIBUTO SPESE DI SPEDIZIONE PER ORDINI INFERIORI A 500 PUNTI ITALY Delivery charge for orders under 500 Italy points Frais de livraison pour les commandes inférieures à 500 points Gastos de envío para pedidos inferiores a 500 puntos Lieferkosten für Bestellungen unter 500 Punkten		50	
CONTRIBUTO SPESE DI SPEDIZIONE PER ORDINI INFERIORI A 750 PUNTI WORLD Shipping fee contribution for orders under 750 World points Frais de livraison pour les commandes inférieures à 750 points Gastos de envío para pedidos inferiores a 750 puntos Lieferkosten für Bestellungen unter 750 Punkten		75	
RILIEVO QUOTA DA SAGOMA Height measurement from template Mesure de la hauteur à partir du gabarit Medición de la altura a partir de la plantilla Höhenmessung von der Schablone		180	
PROGETTAZIONE ELEMENTO SPECIALE Special element design Conception d'éléments spéciaux Diseño de elementos especiales Besonderes Element Design		100	

Basi con maniglia
Base units with handle

Basi con gola
Base units with groove

Colonne
Tall units

Pensili
Wall units

Elementi speciali
Special elements

Maniglie gole zoccoli
Handles grooves plinth

Illuminazione
Lighting

Accessori
Accessories

Componenti e meccanismi
Components e mechanism



BASI CON MANIGLIA

Base units with handle
Bases avec poignée
Bases con tirador
Unterschränke mit Griff

H. 39	P. 35
<ul style="list-style-type: none"> BASI Base units Bases Bases Unterschränke 	P. 35
H. 45,5	P. 36
<ul style="list-style-type: none"> BASI Base units Bases Bases Unterschränke 	P. 36
H. 58,5	P. 37
<ul style="list-style-type: none"> BASI base units bases bases Unterschränke BASI PIANO COTTURA hob base units Bases cuisson bases para hornear Kochfeld Unterschränke BASI LAVELLO sink base units Bases sous évier bases fregadero Spülenunterschrank 	P. 37 P. 38 P. 39
H. 78	P. 40
<ul style="list-style-type: none"> BASI base units bases bases Unterschränke BASI PIANO COTTURA E FORNO hob base units for oven Bases cuisson et four bases para hornear con horno Kochfeld/Backofen Unterschränke BASI LAVELLO sink base units Bases sous évier bases fregadero Spülenunterschrank BASI ANGOLO corner base units bases d'angle bases ángulo eckunterschranke ANTE E STRUTTURE PER ELETTRODOMESTICI doors and frames for household appliances portes et structures pour électroménagers puertas y estructuras para electrodomésticos türen und Rahmen für Elektrogeräte 	P. 40 P. 47 P. 53 P. 56 P. 58

Basi con maniglia
Base units with handle

Basi con gola
Base units with groove

Colonne
Tall units

Pensili
Wall units

Elementi speciali
Special elements

Maniglie gole zoccoli
Handles grooves plinth

Illuminazione
Lighting

Accessori
Accessories

Componenti e meccanismi
Components e mechanism

MAGGIORAZIONI BASI

Basic surcharges
Suppléments de base
Recargos básicos
Grundlegende Zuschläge

Consulta l'elenco completo delle maggiorazioni a pag. 30

See the full list of surcharges on page 30

Voir la liste complète des suppléments à la page 30

Consulte la lista completa de recargos a la página 30

Siehe die vollständige Liste der Zuschläge auf Seite 30

MAGGIORAZIONI ENHANCEMENTS SUPPLÉMENTS RECARGOS AUFPREISEN	PUNTI POINTS POINTS PUNTOS PUNKTE
MECCANISMO ARENA STYLE PER ESTRAIBILE L. 15 KESSEBOHMER Arena Style mechanism for pull-out L. 15 Kessebohmer Pour le mécanisme Arena Style pour l'extraction L. 15 Kessebohmer Para mecanismo Arena Style para extracción L. 15 Kessebohmer Für Arena Style Mechanismus für Auszug L. 15 Kessebohmer	95
MECCANISMO LINEA PURE PER ESTRAIBILE L. 30 KESSEBOHMER For Linea Pure mechanism for pull-out L. 30 Kessebohmer Pour mécanisme Pure Line pour pull-out L. 30 Kessebohmer Para mecanismo Pure Line para extracción L. 30 Kessebohmer Für Mechanik Pure Line für Auszug L. 30 Kessebohmer	119
MECCANISMO LINEA PURE PER BASE ANGOLO KESSEBOHMER For Linea Pure mechanism for Kessebohmer corner base Pour mécanisme Pure Line pour base d'angle Kessebohmer Para mecanismo Linea Pure para base de esquina Kessebohmer Für Mechanik Pure Line für Kessebohmer Ecksocket	269

BASI CON MANIGLIA

H. 39

Base units with handle
Bases avec poignée
Bases con tirador
Unterschranke mit Griff

Base 1 cestone

Base unit 1 deep drawer
Base 1 panier
Base 1 cajón
Unterschrank 1 Schublade

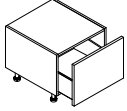

P/D	L/W	CODICE	0	1	2	3	4	5	6	7	8	9	10
57	45	KBN500390454	296	307	319	341	359	365	378	412	506	606	706
57	60	KBN500390604	314	329	338	365	387	396	406	444	545	655	755
57	75	KBN500390754	337	355	361	395	418	432	448	492	601	721	821
57	90	KBN500390904	353	390	402	414	438	464	478	525	645	773	873
57	105	KBN500391054	390	406	418	460	482	514	536	583	719	861	961
57	120	KBN500391204	434	452	466	507	535	563	599	646	789	947	1.047
67	45	KBN500390457	344	359	373	397	409	432	446	491	590	709	809
67	60	KBN500390607	365	378	393	418	436	464	474	526	632	759	859
67	75	KBN500390757	391	406	418	452	476	506	524	577	695	834	934
67	90	KBN500390907	407	417	438	474	492	517	543	611	739	886	986
67	105	KBN500391057	443	450	477	520	536	568	605	677	817	981	1.081
67	120	KBN500391207	471	477	509	553	572	601	638	726	876	1.051	1.151

Base 2 cassetti

Base unit 2-drawers
Base 2 tiroirs
Base de 2 cajones
2-Schubladen-Unterschrank

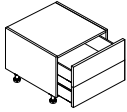

P/D	L/W	CODICE	0	1	2	3	4	5	6	7	8	9	10
57	45	KBN600390454	364	375	387	409	427	433	446	480	576	676	776
57	60	KBN600390604	382	397	405	433	455	464	474	512	615	725	825
57	75	KBN600390754	404	423	429	463	486	500	516	560	671	791	891
57	90	KBN600390904	421	458	469	482	506	532	546	593	715	843	943
57	105	KBN600391054	458	474	486	528	550	582	604	651	789	931	1.031
57	120	KBN600391204	501	520	534	575	603	631	667	714	859	1.017	1.117
67	45	KBN600390457	412	427	441	465	477	500	514	559	660	779	879
67	60	KBN600390607	433	446	461	486	503	532	542	594	702	829	929
67	75	KBN600390757	459	474	486	520	544	574	592	645	765	904	1.004
67	90	KBN600390907	475	485	506	542	560	585	611	679	809	956	1.056
67	105	KBN600391057	511	518	545	588	604	636	673	745	887	1.051	1.151
67	120	KBN600391207	539	545	577	621	640	669	706	793	946	1.121	1.221

Basi con maniglia
Base units with handle

Basi con gola
Base units with groove

Colonne
Tall units

Pensili
Wall units

Elementi speciali
Special elements

Maniglie gole zoccoli
Handles grooves plinth

Illuminazione
Lighting

Accessori
Accessories

Componenti e meccanismi
Components e mechanism

BASI CON MANIGLIA

H. 45,5

Base units with handle
Bases avec poignée
Bases con tirador
Unterschränke mit Griff

Base 1 anta

Base unit with 1 hinged door
Base 1 porte
Base 1 puerta
Unterschrank 1 Tür

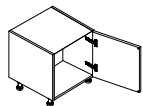

P/D	L/W	CODICE	0	1	2	3	4	5	6	7	8	9	10
34	45	KBN010450451	118	150	155	168	181	184	190	216	269	321	421
34	60	KBN010450601	125	153	156	178	186	194	204	239	299	359	459
57	45	KBN010450454	126	165	184	201	223	233	252	307	380	463	563
57	60	KBN010450604	146	178	194	227	252	268	293	349	435	524	624
67	45	KBN010450457	138	177	196	210	235	244	264	317	390	450	550
67	60	KBN010450607	157	189	204	237	262	279	305	361	447	536	636

Base 2 ante

Base unit with 2 hinged doors
Base 2 portes
Base de 2 puertas
2-türiger Unterschrank

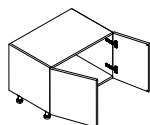

P/D	L/W	CODICE	0	1	2	3	4	5	6	7	8	9	10
57	90	KBN020450904	199	246	287	341	386	406	447	552	687	827	927
67	90	KBN020450907	209	260	299	353	406	419	456	561	699	841	941

Base 1 cestone

Base unit 1 deep drawer
Base 1 panier
Base 1 cajón
Unterschrank 1 Schublade

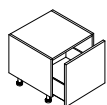

P/D	L/W	CODICE	0	1	2	3	4	5	6	7	8	9	10
57	45	KBN500450454	307	319	331	353	371	376	390	424	518	618	718
57	60	KBN500450604	326	340	349	376	399	407	418	456	557	667	767
57	75	KBN500450754	348	367	372	406	430	443	460	503	613	733	833
57	90	KBN500450904	365	402	413	426	450	475	490	536	657	785	885
57	105	KBN500451054	402	418	430	471	494	526	548	595	731	873	973
57	120	KBN500451204	445	464	477	519	547	574	611	658	801	959	1.059
67	45	KBN500450457	356	371	385	408	421	443	458	502	602	721	821
67	60	KBN500450607	376	390	404	430	447	475	486	537	644	771	871
67	75	KBN500450757	403	418	430	464	488	518	535	589	707	846	946
67	90	KBN500450907	419	429	450	486	503	529	555	623	751	898	998
67	105	KBN500451057	455	462	489	532	548	580	617	689	829	993	1.093
67	120	KBN500451207	483	489	521	565	584	613	650	737	888	1.063	1.163

BASI CON MANIGLIA

H. 58,5

Base units with handle
Bases avec poignée
Bases con tirador
Unterschranke mit Griff

Base 1 anta

Base unit with 1 hinged door
Base 1 porte
Base 1 puerta
Unterschrank 1 Tür

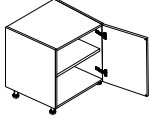

P/D	L/W	CODICE	0	1	2	3	4	5	6	7	8	9	10
34	45	KBN010580451	128	165	182	201	224	234	253	307	383	463	563
34	60	KBN010580601	146	178	199	227	252	268	293	350	435	524	624
57	45	KBN010580454	140	177	194	212	236	245	265	319	395	475	575
57	60	KBN010580604	157	189	210	239	264	279	305	362	447	536	636
67	45	KBN010580457	147	182	201	220	242	253	271	327	404	484	584
67	60	KBN010580607	165	199	237	244	270	287	311	369	455	546	646

Base 2 ante

Base unit with 2 hinged doors
Base 2 portes
Base de 2 puertas
2-türiger Unterschrank

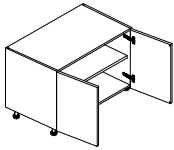

P/D	L/W	CODICE	0	1	2	3	4	5	6	7	8	9	10
34	90	KBN020580901	199	246	287	341	386	406	447	552	687	827	927
57	90	KBN020580904	210	258	299	353	398	418	459	564	699	839	939
67	90	KBN020580907	220	272	310	365	408	431	468	572	711	853	953

Base 1 estraibile + 1 cassetto interno

Base unit 1 pull-out deep drawer + 1 internal drawer
Base 1 extractible + 1 tiroir intérieur
Base 1 extraíble + 1 cajón interior
Unterschrank 1 Auszug + 1 Innenschubladen

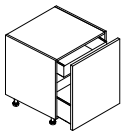

P/D	L/W	CODICE	0	1	2	3	4	5	6	7	8	9	10
57	45	KBN510580454	331	359	391	426	448	466	490	547	677	813	912
57	60	KBN510580604	348	391	415	460	489	503	541	621	766	920	1.020
57	75	KBN510580754	406	418	442	495	520	540	589	674	839	1.004	1.104
57	90	KBN510580904	460	480	521	568	601	622	671	760	942	1.130	1.230
57	105	KBN510581054	485	502	544	601	629	652	695	803	977	1.174	1.274
57	120	KBN510581204	534	554	600	668	690	712	772	901	1.112	1.333	1.433
67	45	KBN510580457	417	443	477	514	535	555	574	635	787	945	1.045
67	60	KBN510580607	437	477	502	547	572	594	631	706	877	1.052	1.152
67	75	KBN510580757	499	510	534	588	609	632	680	767	950	1.141	1.241
67	90	KBN510580907	553	579	619	669	700	722	769	857	1.060	1.272	1.372
67	105	KBN510581057	578	600	642	699	726	748	789	900	1.091	1.310	1.410
67	120	KBN510581207	611	635	680	748	772	794	853	982	1.213	1.456	1.556

Basi con maniglia
Base units with handle

Basi con gola
Base units with groove

Colonne
Tall units

Pensili
Wall units

Elementi speciali
Special elements

Maniglie gole zoccoli
Handles grooves plinth

Illuminazione
Lighting

Accessori
Accessories

Componenti e meccanismi
Components e mechanism

BASI CON MANIGLIA PIANO COTTURA

H. 58,5

Hob base unit with handle
Bases cuisson avec poignée
Bases con tirador
Kochfeld Unterschränke mit Griff

Base cottura 1 anta

Hob base unit 1 hinged door
Base cuisson 1 porte
Base para hornear 1 puerta
Unterschrank für Kochfeldunterschrank 1 Tür

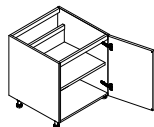

P/D	L/W	CODICE	0	1	2	3	4	5	6	7	8	9	10
57	45	KBC010580454	169	195	213	234	254	266	284	340	417	498	598
57	60	KBC010580604	178	211	231	257	282	300	324	377	465	555	655
67	45	KBC010580457	177	201	221	242	261	275	290	346	426	508	439
67	60	KBC010580607	187	219	237	265	288	308	331	384	473	565	665

Base cottura 2 ante

Hob base unit with 2 hinged doors
Base cuisson 2 portes
Base para hornear 2 puertas
Kochfeldunterschrank 2 Türen

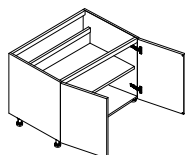

P/D	L/W	CODICE	0	1	2	3	4	5	6	7	8	9	10
57	90	KBC020580904	249	296	332	376	419	427	477	559	689	825	925
67	90	KBC020580907	261	307	343	386	429	437	487	570	702	839	939

Base cottura 1 estraibile + 1 cassetto interno

Hob base unit 1 pull-out + 1 inner drawer
Base cuisson 1 extractible + 1 tiroir intérieur
Base para hornear 1 extraíble + 1 cajón interior
Kochfeldunterschrank 1 Auszug + 1 Innenschubkasten

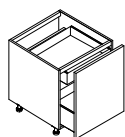

P/D	L/W	CODICE	0	1	2	3	4	5	6	7	8	9	10
57	45	KBC510580454	342	371	403	437	460	477	501	559	689	825	924
57	60	KBC510580604	360	403	427	471	501	515	553	632	778	932	1.032
57	75	KBC510580754	418	430	454	506	532	552	600	686	851	1.016	1.116
57	90	KBC510580904	471	492	533	580	613	633	683	772	954	1.142	1.242
57	105	KBC510581054	497	514	556	613	640	663	707	815	989	1.186	1.286
57	120	KBC510581204	546	566	612	680	701	724	784	913	1.124	1.345	1.445
67	45	KBC510580457	429	455	489	526	547	566	586	647	799	957	1.057
67	60	KBC510580607	449	489	514	559	584	605	642	718	889	1.064	1.164
67	75	KBC510580757	510	522	546	599	621	644	692	779	962	1.153	1.253
67	90	KBC510580907	565	591	631	681	712	733	781	868	1.072	1.284	1.384
67	105	KBC510581057	590	612	654	711	737	760	800	912	1.103	1.322	1.422
67	120	KBC510581207	623	647	692	760	784	806	864	993	1.225	1.468	1.568

BASI CON MANIGLIA LAVELLO

H. 58,5

Sink base unit with handle
Bases sous évier avec poignée
Bases fregadero con tirador
Spülenunterschranke mit Griff

Base livello 1 anta

Sink base unit 1 door
Base sous évier 1 porte
Base fregadero 1 puerta
Spülenunterschrank 1 Tür

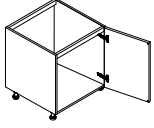

P/D	L/W	CODICE	0	1	2	3	4	5	6	7	8	9	10
57	45	KBL010580454	157	183	202	222	243	254	273	328	405	486	586
57	60	KBL010580604	167	200	219	245	271	288	312	366	453	543	643
67	45	KBL010580457	165	189	210	230	249	263	278	335	414	496	427
67	60	KBL010580607	176	208	225	253	276	297	319	372	461	553	653

Base livello 2 ante

Sink base unit 2 door
Base sous évier 2 portes
Base fregadero de 2 puertas
2-türiger Spülenunterschrank

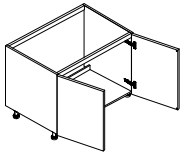

P/D	L/W	CODICE	0	1	2	3	4	5	6	7	8	9	10
57	90	KBL020580904	238	284	320	365	407	415	466	547	677	813	913
67	90	KBL020580907	249	295	332	374	417	426	475	559	690	827	927

Base livello 1 estraibile

Sink base unit 1 pull-out
Base sous évier 1 extractible
Base fregadero 1 extraíble
Spülenunterschrank 1 Auszug

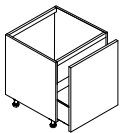

P/D	L/W	CODICE	0	1	2	3	4	5	6	7	8	9	10
57	45	KBL500580454	224	250	236	269	294	308	350	402	505	606	706
57	60	KBL500580604	232	239	243	276	302	315	358	408	513	614	714
57	75	KBL500580754	279	288	299	338	365	382	432	491	610	730	830
57	90	KBL500580904	331	337	362	400	431	449	505	569	707	848	948
57	105	KBL500581054	380	392	408	461	495	518	579	652	804	964	1.064
57	120	KBL500581204	432	446	465	524	560	586	655	732	903	1.082	1.182
67	45	KBL500580457	231	323	330	357	380	392	435	485	603	723	823
67	60	KBL500580607	313	331	338	365	388	404	442	493	611	731	831
67	75	KBL500580757	348	362	373	407	434	449	501	559	691	828	928
67	90	KBL500580907	382	393	414	452	482	501	560	624	772	925	1.025
67	105	KBL500581057	417	435	446	499	534	554	618	689	852	1.022	1.122
67	120	KBL500581207	452	469	489	542	583	605	674	756	933	1.119	1.219

Basi con maniglia
Base units with handle

Basi con gola
Base units with groove

Colonne
Tall units

Pensili
Wall units

Elementi speciali
Special elements

Maniglie gole zoccoli
Handles grooves plinth

Illuminazione
Lighting

Accessori
Accessories

Componenti e meccanismi
Components e mechanism

BASI CON MANIGLIA

Base units with handle
Bases avec poignée
Bases con tirador
Unterschranke mit Griff

H. 78

Riempitivo per base

Base unit filler
Fileur pour base
Regleta para base
Unterschrank-Füllstoff

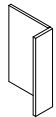

P/D	L/W	CODICE	0	1	2	3	4	5	6	7	8	9	10
34	4-15	KBN900780151	79	88	95	125	132	402	151	204	262	314	364

Base 1 anta

Base unit with 1 hinged door
Base 1 porte
Base 1 puerta
Unterschrank 1 Tür

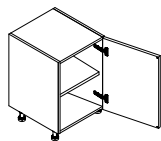

P/D	L/W	CODICE	0	1	2	3	4	5	6	7	8	9	10
34	15	KBN010780151	118	150	155	168	181	184	190	216	269	321	371
34	30	KBN010780301	133	161	174	202	217	218	235	269	331	396	446
34	45	KBN010780451	143	186	204	243	267	272	290	329	405	487	537
34	60	KBN010780601	157	196	220	270	297	304	337	391	486	583	633
34	75	KBN010780751	198	247	273	340	380	386	426	503	624	748	798
57	15	KBN010780154	118	150	155	168	181	184	190	216	269	321	371
57	30	KBN010780304	133	161	174	202	217	218	235	269	331	396	446
57	45	KBN010780454	143	186	204	243	267	272	290	329	405	487	537
57	60	KBN010780604	157	196	220	270	297	304	337	391	486	583	633
57	75	KBN010780754	198	247	273	340	380	386	426	503	624	748	798
67	15	KBN010780157	125	153	156	178	186	194	204	242	299	359	409
67	30	KBN010780307	143	174	181	210	224	226	243	276	342	410	460
67	45	KBN010780457	152	196	212	250	275	279	301	338	420	504	554
67	60	KBN010780607	166	205	230	277	306	313	347	402	496	595	645
67	75	KBN010780757	212	259	284	353	395	401	440	517	640	766	806

BASI CON MANIGLIA

H. 78

Base units with handle
Bases avec poignée
Bases con tirador
Unterschranke mit Griff

Base 1 anta + 2 cestoni interni

Base unit with 1 hinged door + 2 inner baskets
Base 1 porte + 2 paniers intérieurs
Base 1 puerta + 2 cestas interiores
Unterschrank 1 Tür + 2 Schubkasten

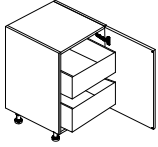

P/D	L/W	CODICE	0	1	2	3	4	5	6	7	8	9	10
57	45	KBK100780454	372	416	432	469	490	532	547	592	731	878	928
57	60	KBK100780604	391	435	453	503	526	571	605	663	819	983	1.033
57	75	KBK100780754	409	453	477	536	563	611	640	736	911	1.092	1.142
67	45	KBK100780457	481	528	540	580	594	649	662	702	869	1.042	1.092
67	60	KBK100780607	501	544	564	613	630	690	718	773	956	1.148	1.198
67	75	KBK100780757	526	567	592	651	672	734	755	851	1.053	1.263	1.313

Base 1 anta + 2 cassetti + 1 cestone interno

Base unit with 1 hinged door + 2 drawers + 1 inner basket
Base 1 porte + 2 tiroirs + 1 panier intérieur
Base 1 puerta + 2 cajones + 1 cajón interior
Unterschrank 1 Tür + 2 Schubladen + 1 Innenschubkast

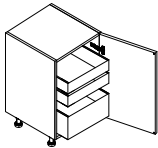

P/D	L/W	CODICE	0	1	2	3	4	5	6	7	8	9	10
57	45	KBK110780454	415	461	476	514	532	579	611	636	788	946	996
57	60	KBK110780604	437	480	500	549	567	613	651	708	877	1.052	1.102
57	75	KBK110780754	453	496	523	581	605	660	686	783	967	1.160	1.210
67	45	KBK110780457	546	592	605	645	655	718	750	766	949	1.139	1.189
67	60	KBK110780607	566	610	628	679	690	754	785	837	1.038	1.246	1.296
67	75	KBK110780757	589	629	656	715	733	803	819	917	1.133	1.360	1.410

Base 2 ante

Base unit with 2 hinged doors
Base 2 portes
Base de 2 puertas
2-türiger Unterschrank

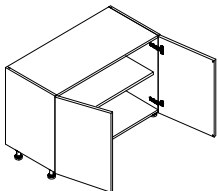

P/D	L/W	CODICE	0	1	2	3	4	5	6	7	8	9	10	
34	60	KBN020780601	184	235	250	309	341	345	379	443	551	660	710	
34	90	KBN020780901	210	258	295	372	417	434	476	563	695	833	883	
■	34	120	KBN020781201	242	292	347	446	203	554	592	699	862	1.036	1.086
57	60	KBN020780604	184	235	250	309	341	345	379	443	551	660	710	
57	90	KBN020780904	210	258	295	372	417	434	476	563	695	833	883	
■	57	120	KBN020781204	242	292	347	446	203	554	592	699	862	1.036	1.086
67	60	KBN020780607	193	245	259	319	350	355	388	452	560	673	723	
67	90	KBN020780907	222	274	309	384	433	447	490	574	712	854	904	
■	67	120	KBN020781207	258	305	365	459	509	564	603	712	880	1.056	1.106

■ ripiano fornito con profilo di copertura | shelf supplied with cover profile | étagère fournie avec un profilé de couverture | estante con perfil de cubierta |
Fachboden mit Abdeckprofil geliefert

Basi con maniglia
Base units with handle

Basi con gola
Base units with groove

Colonne
Tall units

Pensili
Wall units

Elementi speciali
Special elements

Maniglie gole zoccoli
Handles grooves plinth

Illuminazione
Lighting

Accessori
Accessories

Componenti e meccanismi
Components e mechanism

BASI CON MANIGLIA

Base units with handle
Bases avec poignée
Bases con tirador
Unterschränke mit Griff

H. 78

Base 1 estraibile con meccanismo Linea Pro Sige

Base unit 1 pull-out deep drawer with mechanism Linea Pro Sige
Base 1 extractible avec mécanisme Linea Pro Sige
Base 1 extraíble con mecanismo Linea Pro Sige
Unterschrank 1 Auszug mit Mechanismus Linea Pro Sige

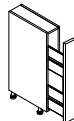

P/D	L/W	CODICE	0	1	2	3	4	5	6	7	8	9	10
57	15	KBN700780154	171	211	215	234	239	253	262	274	339	405	445

Maggiorazione per meccanismo Arena Style Kessebohrer PUNTI 95

Arena Style Kessebohrer mechanism | Supplément pour le mécanisme Arena Style Kessebohrer | Recargo para mecanismo Arena Style Kessebohrer | Aufpreis für Arena Style Kessebohrer Mechanismus

Base 1 estraibile con meccanismo Linea Pro Sige

Base unit 1 pull-out deep drawer with mechanism Linea Pro Sige
Base 1 extractible avec mécanisme Linea Pro Sige
Base 1 extraíble con mecanismo Linea Pro Sige
Unterschrank 1 Auszug mit Mechanismus Linea Pro Sige

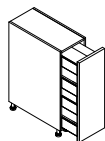

P/D	L/W	CODICE	0	1	2	3	4	5	6	7	8	9	10
57	30	KBN700780304	425	467	477	503	527	567	579	628	716	832	882

Maggiorazione per meccanismo Linea Pure Kessebohrer PUNTI 119

Mechanism Pure Kessebohrer Line | Supplément pour le mécanisme Linea Pure Kessebohrer | Recargo para mecanismo Linea Pure Kessebohrer | Aufpreis für Mechanismus Pure Kessebohrer Line

Base 4 cassetti

Base unit 4-drawer
Base 4 tiroirs
Base de 4 cajones
4-Schubladen-Unterschrank

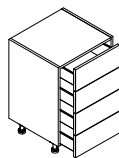

P/D	L/W	CODICE	0	1	2	3	4	5	6	7	8	9	10
57	45	KBN620780454	476	546	569	635	674	718	774	837	1.037	1.245	1.345
57	60	KBN620780604	491	568	585	664	698	751	793	876	1.082	1.298	1.398
57	75	KBN620780754	511	586	614	700	740	805	866	959	1.185	1.422	1.522
57	90	KBN620780904	535	601	646	736	774	835	905	1.012	1.251	1.501	1.601
57	105	KBN620781054	560	621	677	784	817	888	964	1.075	1.332	1.598	1.698
57	120	KBN620781204	580	637	706	808	857	933	1.022	1.142	1.412	1.695	1.795
67	45	KBN620780457	642	714	728	800	839	896	947	1.016	1.255	1.508	1.608
67	60	KBN620780607	656	734	749	830	861	930	959	1.052	1.301	1.562	1.662
67	75	KBN620780757	683	756	785	870	919	1.007	1.042	1.141	1.410	1.694	1.794
67	90	KBN620780907	705	772	815	906	937	1.020	1.077	1.187	1.468	1.762	1.862
67	105	KBN620781057	729	889	846	954	986	1.092	1.136	1.246	1.542	1.849	1.949
67	120	KBN620781207	751	807	876	980	1.025	1.107	1.192	1.312	1.623	1.947	2.047

BASI CON MANIGLIA

H. 78

Base units with handle
Bases avec poignée
Bases con tirador
Unterschranke mit Griff

Base 2 cassetti + 1 cestone

Base unit 2-drawers + 1 deep drawer
Base 2 tiroirs + 1 panier
Base 2 cajones + 1 cajón
Unterschrank 2 Schubladen + 1 Schubkast

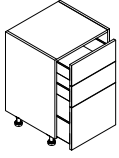

P/D	L/W	CODICE	0	1	2	3	4	5	6	7	8	9	10
57	45	KBN610780454	421	480	491	554	572	623	649	690	850	1.020	1.070
57	60	KBN610780604	439	505	521	592	610	662	690	749	921	1.106	1.156
57	75	KBN610780754	456	528	553	630	656	714	742	823	1.011	1.214	1.264
57	90	KBN610780904	472	546	585	665	696	749	797	893	1.100	1.320	1.370
57	105	KBN610781054	506	568	617	711	734	803	853	978	1.203	1.442	1.492
57	120	KBN610781204	560	603	663	760	792	781	925	1.056	1.300	1.559	1.609
67	45	KBN610780457	553	610	621	684	699	763	779	821	1.010	1.213	1.263
67	60	KBN610780607	568	636	652	721	733	800	821	880	1.083	1.299	1.349
67	75	KBN610780757	592	661	687	764	790	853	880	954	1.179	1.414	1.464
67	90	KBN610780907	606	680	717	799	828	884	931	1.028	1.266	1.519	1.569
67	105	KBN610781057	640	703	748	849	868	938	986	1.110	1.370	1.643	1.693
67	120	KBN610781207	677	724	880	879	911	995	1.045	1.177	1.450	1.740	1.790

Base 1 cassetto + 1 estraibile + cassetto interno

Base unit 1 drawer + 1 pull-out deep drawer + inner drawer
Base 1 tiroir + 1 extractible + tiroir intérieur
Base 1 cajón + 1 extraible + cajón interior
Unterschrank 1 Schublade + 1 Auszug + Innenschublade

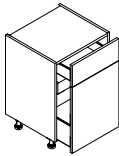

P/D	L/W	CODICE	0	1	2	3	4	5	6	7	8	9	10
57	45	KBN590780454	418	477	489	551	570	621	646	688	848	1.018	1.118
57	60	KBN590780604	442	508	524	595	613	664	694	751	924	1.109	1.209
57	75	KBN590780754	464	536	561	638	664	722	751	831	1.020	1.223	1.323
57	90	KBN590780904	486	561	598	682	711	762	811	908	1.115	1.335	1.435
57	105	KBN590781054	561	647	691	790	823	882	939	1.052	1.294	1.550	1.650
57	120	KBN590781204	639	737	789	901	937	1.005	1.073	1.203	1.477	1.769	1.869
67	45	KBN590780457	594	652	663	726	741	805	819	862	1.053	1.256	1.356
67	60	KBN590780607	621	689	703	773	786	853	874	933	1.138	1.353	1.453
67	75	KBN590780757	655	724	750	827	853	917	944	1.019	1.245	1.489	1.589
67	90	KBN590780907	681	755	792	874	903	957	1.006	1.102	1.343	1.595	1.695
67	105	KBN590781057	783	870	911	1.008	1.042	1.106	1.162	1.274	1.555	1.850	1.950
67	120	KBN590781207	885	985	1.029	1.143	1.180	1.253	154	1.446	1.766	2.103	2.203

Base 1 cassetto + 1 anta

Base unit 1 drawer + 1 hinged door
Base 1 tiroir + 1 porte
Base 1 cajón + 1 puerta
Unterschrank 1 Schublade + 1 Tür

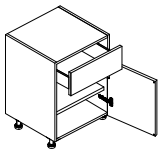

P/D	L/W	CODICE	0	1	2	3	4	5	6	7	8	9	10
57	45	KBN570780454	280	331	372	431	460	499	521	575	721	884	934
57	60	KBN570780604	296	353	384	440	471	505	527	585	731	897	937
67	45	KBN570780457	362	410	450	508	538	583	604	656	806	984	1.034
67	60	KBN570780607	375	434	466	523	552	592	611	665	816	997	1.047

Basi con maniglia
Base units with handle

Basi con gola
Base units with groove

Colonne
Tall units

Pensili
Wall units

Elementi speciali
Special elements

Maniglie gole zoccoli
Handles grooves plinth

Illuminazione
Lighting

Accessori
Accessories

Componenti e meccanismi
Components e mechanism

BASI CON MANIGLIA

Base units with handle
Bases avec poignée
Bases con tirador
Unterschränke mit Griff

H. 78

Base 1 cassetto + 2 ante

Base unit 1 drawer + 2 hinged doors
Base 1 tiroir + 2 portes
Base 1 cajón + 2 puertas
Unterschrank 1 Schublade + 2 Türen

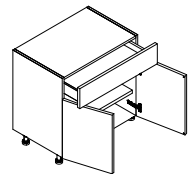

P/D	L/W	CODICE	0	1	2	3	4	5	6	7	8	9	10
57	90	KBN580780904	392	469	482	557	589	643	678	772	972	1.187	1.237
67	90	KBN580780907	464	514	528	585	619	683	709	757	950	1.161	1.211

Base 2 cestoni

Base unit 2 deep drawers
Base 2 paniers
Base 2 cestas
Unterschrank 2 Schubkasten

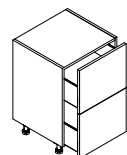

P/D	L/W	CODICE	0	1	2	3	4	5	6	7	8	9	10
57	45	KBN540780454	372	421	464	521	550	589	611	665	815	977	1.027
57	60	KBN540780604	386	443	475	532	562	596	618	674	825	991	1.041
57	75	KBN540780754	404	481	485	553	585	649	672	738	904	1.085	1.135
57	90	KBN540780904	417	496	506	580	617	699	728	798	980	1.176	1.136
57	105	KBN540781054	485	554	594	669	696	792	820	910	1.117	1.341	1.394
57	120	KBN540781204	583	637	691	780	818	889	960	1.050	1.282	1.539	1.589
67	45	KBN540780457	451	501	541	599	630	673	695	747	898	1.078	1.138
67	60	KBN540780607	467	525	557	612	642	682	702	757	910	1.090	1.140
67	75	KBN540780757	482	561	566	631	664	733	757	819	986	1.184	1.234
67	90	KBN540780907	499	576	587	661	696	784	809	882	1.064	1.277	1.327
67	105	KBN540781057	567	631	673	749	775	878	901	989	1.198	1.440	1.490
67	120	KBN540781207	653	706	762	851	888	960	1.028	1.117	1.373	1.647	1.697

Base 2 cestoni + 1 cassetto interno

Base unit 2 baskets + 1 internal drawer
Base 2 paniers + 1 tiroir intérieur
Base 2 cestas + 1 cajón interior
Unterschrank 2 Schubkasten + 1 Innenschublade

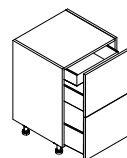

P/D	L/W	CODICE	0	1	2	3	4	5	6	7	8	9	10
57	45	KBN560780454	437	489	502	559	593	656	671	721	886	1.063	1.113
57	60	KBN560780604	456	514	533	592	617	670	711	791	974	1.168	1.218
57	75	KBN560780754	474	541	563	624	647	706	757	844	1.039	1.247	1.297
57	90	KBN560780904	494	570	585	658	691	745	781	874	1.077	1.292	1.342
57	105	KBN560781054	555	632	669	749	779	850	900	1.006	1.198	1.440	1.490
57	120	KBN560781204	698	754	803	893	929	1.002	1.072	1.161	1.423	1.707	1.757
67	45	KBN560780457	566	617	630	687	721	785	812	858	1.055	1.266	1.316
67	60	KBN560780607	589	647	663	724	742	814	852	933	1.148	1.377	1.427
67	75	KBN560780757	610	678	698	760	781	857	896	986	1.215	1.458	1.508
67	90	KBN560780907	629	707	718	794	827	884	919	1.012	1.247	1.495	1.545
67	105	KBN560781057	690	769	801	886	914	990	1.036	1.145	1.370	1.643	1.693
67	120	KBN560781207	779	831	886	978	1.014	1.084	1.153	1.244	1.532	1.840	1.890

BASI CON MANIGLIA

H. 78

Base units with handle
Bases avec poignée
Bases con tirador
Unterschranke mit Griff

Base 1 estraibile + 1 cestone interno

Base unit 1 pull-out deep drawer + 1 inner basket
Base 1 extractible + 1 panier intérieur
Base 1 extraible + 1 cajón interior
Unterschrank 1 Auszug + 1 Innenschubladen

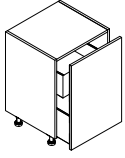

P/D	L/W	CODICE	0	1	2	3	4	5	6	7	8	9	10
57	45	KBN530780454	372	416	432	469	490	532	547	592	731	878	928
57	60	KBN530780604	391	435	453	503	526	571	605	663	819	983	1.033
57	75	KBN530780754	409	453	477	536	563	611	640	736	911	1.092	1.142
67	45	KBN530780457	481	528	540	580	594	649	662	702	869	1.042	1.092
67	60	KBN530780607	501	544	564	613	630	690	718	773	956	1.148	1.198
67	75	KBN530780757	526	567	592	651	672	734	755	851	1.053	1.263	1.313

Base 1 estraibile + 2 cassetti interni

Base unit 1 pull-out deep drawer + 2 internal drawers
Base 1 extractible + 2 tiroirs intérieurs
base 1 extraible + 2 cajones interiores
Unterschrank 1 Auszug + 2 Innenschubladen

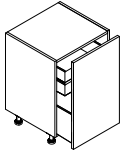

P/D	L/W	CODICE	0	1	2	3	4	5	6	7	8	9	10
57	45	KBN520780454	415	461	476	514	532	579	611	636	788	946	996
57	60	KBN520780604	437	480	500	549	567	613	651	708	877	1.052	1.102
57	75	KBN520780754	453	496	523	581	605	660	686	783	967	1.160	1.210
67	45	KBN520780457	546	592	605	645	655	718	750	766	949	1.139	1.189
67	60	KBN520780607	566	610	628	679	690	754	785	837	1.038	1.246	1.296
67	75	KBN520780757	589	629	656	715	733	803	819	917	1.133	1.360	1.410

Base 1 estraibile con pattumiera (1 x 35l)

Base unit 1 removable with dustbin (1 x 35l)
Base 1 extractible avec poubelle (1 x 35l)
Base 1 extraible con cubo de basura (1 x 35l)
Unterschrank 1 Auszug mit Mülleimer (1 x 35l)

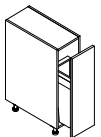

P/D	L/W	CODICE	0	1	2	3	4	5	6	7	8	9	10
57	30	KBN790780304	358	399	412	450	465	520	554	595	766	749	999
67	30	KBN790780307	377	418	432	469	484	539	573	614	786	969	1.019

Basi con maniglia
Base units with handle

Basi con gola
Base units with groove

Colonne
Tall units

Pensili
Wall units

Elementi speciali
Special elements

Maniglie gole zoccoli
Handles grooves plinth

Illuminazione
Lighting

Accessori
Accessories

Componenti e meccanismi
Components e mechanism

BASI CON MANIGLIA

H. 78

Base units with handle
Bases avec poignée
Bases con tirador
Unterschranke mit Griff

Base 1 estraibile con pattumiera (2 x 35l) + 1 cassetto interno

Base unit 1 pull-out with dustbin (2 x 35l) + 1 internal drawer
Base 1 extractible avec poubelle (2 x 35l) + 1 tiroir intérieur
Base 1 extraible con cubo de basura (2 x 35l) + 1 cajón interior
Unterschrank 1 Auszug mit Mülleimer (2 x 35l) + 1 Innenschublade

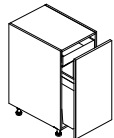

P/D	L/W	CODICE	0	1	2	3	4	5	6	7	8	9	10
57	45	KBN790780454	503	544	558	596	610	665	699	740	916	1.099	1.149
67	45	KBN790780457	523	564	577	615	630	685	719	760	936	1.119	1.169

Base 1 estraibile con pattumiera (2 x 35l + 2 x 8l) + 1 cassetto interno

Base unit 1 pull-out with dustbin (2 x 35l + 2 x 8l) + 1 internal drawer
Base 1 extractible avec poubelle (2 x 35l + 2 x 8l) + 1 tiroir intérieur
Base 1 extraible con cubo de basura (2 x 35l + 2 x 8l) + 1 cajón interior
Unterschrank 1 Auszug mit Mülleimer (2 x 35l + 2 x 8l) + 1 Innenschublade

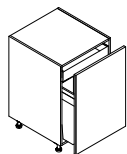

P/D	L/W	CODICE	0	1	2	3	4	5	6	7	8	9	10
57	60	KBN790780604	664	702	720	769	805	879	905	963	1.192	1.431	1.481
67	60	KBN790780607	684	722	739	789	825	801	924	983	1.212	1.451	1.501

BASI CON MANIGLIA PIANO COTTURA E FORNO

H. 78

Hob base unit for oven with handle
Bases cuisson et four avec poignée
Bases para hornear con horno con tirador
Kochfeld/Backofen Unterschränke mit Griff

Base cottura 1 anta

Hob base unit 1 hinged door
Base cuisson 1 porte
Base para hornear 1 puerta
Unterschrank für Kochfeldunterschrank 1 Tür

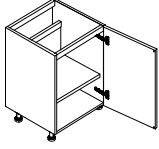

P/D	L/W	CODICE	0	1	2	3	4	5	6	7	8	9	10
57	45	KBC010780454	154	198	215	254	278	283	302	340	417	499	549
57	60	KBC010780604	169	208	232	281	308	315	348	403	498	595	645
57	75	KBC010780754	210	259	284	351	392	398	437	515	636	760	810
67	45	KBC010780457	164	208	224	262	287	291	312	349	432	516	566
67	60	KBC010780607	178	216	242	289	317	325	359	413	508	607	657
67	75	KBC010780757	224	271	296	365	406	412	452	529	652	778	818

Base cottura 2 ante

Hob base unit with 2 hinged doors
Base cuisson 2 portes
Base para hornear 2 puertas
Kochfeldunterschrank 2 Türen

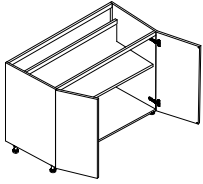

P/D	L/W	CODICE	0	1	2	3	4	5	6	7	8	9	10	
57	60	KBC020780604	196	246	262	321	353	357	391	455	563	672	722	
57	90	KBC020780904	222	270	307	383	429	445	488	574	707	845	895	
■	57	120	KBC020781204	253	304	359	458	214	566	603	711	874	1.048	1.098
67	60	KBC020780607	205	257	271	331	362	367	400	464	572	685	735	
67	90	KBC020780907	234	285	321	396	444	459	501	586	724	866	916	
■	67	120	KBC020781207	270	316	376	470	521	575	615	724	892	1.068	1.118

■ ripiano fornito con profilo di copertura | shelf supplied with cover profile | étagère fournie avec un profilé de couverture | estante con perfil de cubierta |
Fachboden mit Abdeckprofil geliefert

Base cottura 4 cassetti

Hob base unit 4-drawer
Base cuisson à 4 tiroirs
Base para hornear de 4 cajones
Kochfeldunterschrank mit 4 Schubladen

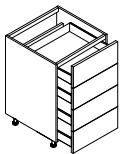

P/D	L/W	CODICE	0	1	2	3	4	5	6	7	8	9	10
57	45	KBC620780454	488	558	581	647	686	729	786	849	1.049	1.257	1.357
57	60	KBC620780604	502	580	597	676	710	762	805	888	1.094	1.310	1.410
57	75	KBC620780754	523	598	626	712	752	817	878	971	1.197	1.434	1.534
57	90	KBC620780904	547	613	658	748	786	847	917	1.023	1.263	1.513	1.613
57	105	KBC620781054	571	632	689	795	828	899	976	1.086	1.344	1.610	1.710
57	120	KBC620781204	592	649	718	820	868	945	1.034	1.153	1.424	1.707	1.807
67	45	KBC620780457	654	726	740	812	851	908	958	1.027	1.267	1.520	1.620
67	60	KBC620780607	667	746	760	842	873	942	971	1.064	1.313	1.574	1.674
67	75	KBC620780757	695	767	796	882	930	1.019	1.053	1.152	1.422	1.706	1.806
67	90	KBC620780907	717	784	826	918	949	1.032	1.088	1.199	1.480	1.774	1.874
67	105	KBC620781057	741	800	857	965	998	1.104	1.148	1.258	1.554	1.861	1.961
67	120	KBC620781207	762	819	888	991	1.037	1.118	1.204	1.324	1.635	1.959	2.059

Basi con maniglia
Base units with handle

Basi con gola
Base units with groove

Colonne
Tall units

Pensili
Wall units

Elementi speciali
Special elements

Maniglie gole zoccoli
Handles grooves plinth

Illuminazione
Lighting

Accessori
Accessories

Componenti e meccanismi
Components e mechanism

BASI CON MANIGLIA PIANO COTTURA E FORNO

H. 78

Hob base unit for oven with handle
Bases cuisson et four avec poignée
Bases para hornear con horno con tirador
Kochfeld/Backofen Unterschränke mit Griff

Base cottura 2 cassetti + 1 cestone

Hob base unit 2 drawers + 1 deep drawer
Base cuisson 2 tiroirs + 1 panier
Base para hornear 2 cajones + 1 cajón
Kochfeldunterschrank 2 Schubladen + 1 Schubkast

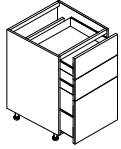

P/D	L/W	CODICE	0	1	2	3	4	5	6	7	8	9	10
57	45	KBC610780454	433	492	502	566	584	634	661	701	862	1.032	1.082
57	60	KBC610780604	451	517	533	603	622	673	701	760	933	1.118	1.168
57	75	KBC610780754	468	539	565	641	667	726	754	834	1.023	1.226	1.276
57	90	KBC610780904	484	558	597	677	708	760	809	905	1.112	1.332	1.382
57	105	KBC610781054	518	580	629	723	746	815	864	989	1.215	1.454	1.504
57	120	KBC610781204	571	615	674	771	803	792	937	1.068	1.312	1.571	1.621
67	45	KBC610780457	565	622	632	695	711	775	791	832	1.022	1.225	1.275
67	60	KBC610780607	580	648	663	732	745	812	832	891	1.095	1.311	1.361
67	75	KBC610780757	603	672	698	776	801	864	891	966	1.191	1.426	1.476
67	90	KBC610780907	618	692	728	811	840	895	943	1.040	1.278	1.531	1.581
67	105	KBC610781057	652	715	760	860	880	950	997	1.121	1.382	1.655	1.705
67	120	KBC610781207	689	735	891	890	922	1.007	1.056	1.188	1.462	1.752	1.802

Base cottura 1 cassetto + 1 estraibile + 1 cassetto interno

Hob base unit 1 drawer + 1 pull-out + 1 inner drawer
Base cuisson 1 tiroir + 1 extractible + 1 tiroir intérieur
Base para hornear 1 cajón + 1 extraíble + 1 cajón interior
Kochfeldunterschrank 1 Schublade + 1 Auszug + 1 Innenschublade

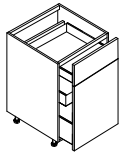

P/D	L/W	CODICE	0	1	2	3	4	5	6	7	8	9	10
57	45	KBC590780454	430	489	501	563	582	632	658	699	860	1.030	1.130
57	60	KBC590780604	454	520	535	606	625	676	705	762	936	1.121	1.221
57	75	KBC590780754	475	548	572	650	676	733	762	843	1.032	1.235	1.335
57	90	KBC590780904	498	572	609	694	723	774	823	920	1.127	1.347	1.447
57	105	KBC590781054	572	659	702	801	834	893	951	1.064	1.306	1.562	1.662
57	120	KBC590781204	651	749	800	913	949	1.017	1.084	1.214	1.489	1.781	1.881
67	45	KBC590780457	605	663	674	737	753	817	830	874	1.065	1.268	1.368
67	60	KBC590780607	632	700	715	785	797	864	886	945	1.150	1.365	1.465
67	75	KBC590780757	666	735	761	839	864	928	955	1.030	1.257	1.501	1.601
67	90	KBC590780907	693	766	803	886	915	969	1.018	1.114	1.355	1.607	1.707
67	105	KBC590781057	794	882	922	1.019	1.053	1.117	1.174	1.285	1.567	1.862	1.962
67	120	KBC590781207	896	996	1.041	1.154	1.191	1.265	166	1.458	1.778	2.115	2.215

Base cottura 1 cassetto + 1 anta

Hob base unit 1 drawer + 1 hinged door
Base cuisson 1 tiroir + 1 porte
Base para hornear 1 cajón + 1 puerta
Kochfeldunterschrank 1 Schublade + 1 Tür

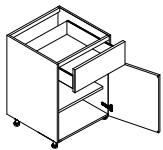

P/D	L/W	CODICE	0	1	2	3	4	5	6	7	8	9	10
57	45	KBC570780454	292	342	384	442	471	510	533	587	733	896	946
57	60	KBC570780604	307	365	396	452	483	517	538	597	743	909	949
67	45	KBC570780457	373	422	462	520	550	595	616	667	818	996	1.046
67	60	KBC570780607	387	445	477	534	564	603	623	677	828	1.009	1.059

BASI CON MANIGLIA PIANO COTTURA E FORNO

H. 78

Hob base unit for oven with handle
Bases cuisson et four avec poignée
Bases para hornear con horno con tirador
Kochfeld/Backofen Unterschränke mit Griff

Base cottura 1 cassetto + 2 ante

Hob base unit 1 drawer + 2 hinged doors
Base cuisson 1 tiroir + 2 portes
Base para hornear 1 cajón + 2 puertas
Kochfeldunterschrank 1 Schublade + 2 Türen

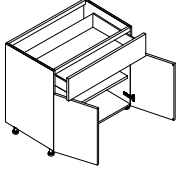

P/D	L/W	CODICE	0	1	2	3	4	5	6	7	8	9	10
57	90	KBC580780904	404	480	494	568	600	655	690	784	984	1.199	1.249
67	90	KBC580780907	475	526	539	597	631	695	721	768	962	1.173	1.223

Base cottura 2 cestoni

Hob base unit with 2 deep drawers
Base cuisson 2 paniers
Base para hornear 2 cestas
Kochfeldunterschrank 2 Schubkasten

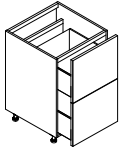

P/D	L/W	CODICE	0	1	2	3	4	5	6	7	8	9	10
57	45	KBC540780454	383	433	475	533	562	600	623	677	827	989	1.039
57	60	KBC540780604	398	455	487	543	573	607	630	686	837	1.003	1.053
57	75	KBC540780754	415	493	497	565	597	661	684	750	916	1.097	1.147
57	90	KBC540780904	429	507	518	592	629	711	740	810	992	1.188	1.148
57	105	KBC540781054	497	566	605	681	708	804	831	922	1.129	1.353	1.406
57	120	KBC540781204	595	649	702	792	829	900	972	1.061	1.294	1.551	1.601
67	45	KBC540780457	463	513	553	611	641	685	707	759	910	1.090	1.150
67	60	KBC540780607	478	536	568	624	654	694	714	768	922	1.102	1.152
67	75	KBC540780757	494	572	577	642	676	745	768	830	998	1.196	1.246
67	90	KBC540780907	510	588	598	672	708	795	821	893	1.076	1.289	1.339
67	105	KBC540781057	579	643	685	760	787	889	913	1.001	1.210	1.452	1.502
67	120	KBC540781207	664	718	774	862	899	972	1.040	1.129	1.385	1.659	1.709

Base cottura 2 cestoni + 1 cassetto interno

Hob base unit with 2 deep drawers + 1 internal drawer
Base cuisson 2 paniers + 1 tiroir intérieur
Base para hornear 2 cestas + 1 cajón interior
Kochfeldunterschrank 2 Schubkasten + 1 Innenschublade

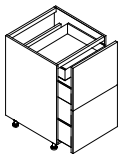

P/D	L/W	CODICE	0	1	2	3	4	5	6	7	8	9	10
57	45	KBC560780454	449	501	514	570	604	667	683	732	898	1.075	1.125
57	60	KBC560780604	468	526	544	603	629	682	723	802	986	1.180	1.230
57	75	KBC560780754	486	553	574	635	659	718	768	856	1.051	1.259	1.309
57	90	KBC560780904	505	582	597	669	702	757	792	886	1.089	1.304	1.354
57	105	KBC560781054	566	644	681	760	791	861	912	1.018	1.210	1.452	1.502
57	120	KBC560781204	710	765	815	905	941	1.014	1.083	1.173	1.435	1.719	1.769
67	45	KBC560780457	577	629	641	698	732	796	824	870	1.067	1.278	1.328
67	60	KBC560780607	600	659	674	735	754	825	863	945	1.160	1.389	1.439
67	75	KBC560780757	622	690	710	772	792	869	908	998	1.227	1.470	1.520
67	90	KBC560780907	640	719	729	806	839	895	930	1.023	1.259	1.507	1.557
67	105	KBC560781057	701	781	813	897	925	1.002	1.048	1.156	1.382	1.655	1.705
67	120	KBC560781207	791	843	897	989	1.025	1.096	1.165	1.255	1.544	1.852	1.902

Basi con maniglia
Base units with handle

Basi con gola
Base units with groove

Colonne
Tall units

Pensili
Wall units

Elementi speciali
Special elements

Maniglie gole zoccoli
Handles grooves plinth

Illuminazione
Lighting

Accessori
Accessories

Componenti e meccanismi
Components e mechanism

BASI CON MANIGLIA PIANO COTTURA E FORNO

H. 78

Hob base unit for oven with handle
Bases cuisson et four avec poignée
Bases para hornear con horno con tirador
Kochfeld/Backofen Unterschränke mit Griff

Base cottura 1 estraibile + 1 cestone interno

Hob base unit 1 pull-out + 1 inner basket
Base cuisson 1 extractible + 1 panier intérieur
Base para hornear 1 extraíble + 1 cajón interior
Kochfeldunterschrank 1 Auszug + 1 Innenschubkasten

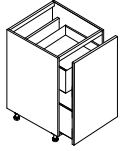

P/D	L/W	CODICE	0	1	2	3	4	5	6	7	8	9	10
57	45	KBC530780454	384	428	443	481	501	543	559	603	743	890	940
57	60	KBC530780604	403	446	465	515	537	583	617	674	831	995	1.045
57	75	KBC530780754	421	465	489	548	574	623	652	748	923	1.104	1.154
67	45	KBC530780457	493	539	552	592	605	661	673	714	881	1.054	1.104
67	60	KBC530780607	513	556	575	625	641	701	729	785	968	1.160	1.210
67	75	KBC530780757	537	579	603	663	684	746	766	862	1.065	1.275	1.325

Base cottura 1 estraibile + 2 cassetti interni

Hob base unit 1 pull-out + 2 internal drawers
Base cuisson 1 extractible + 2 tiroirs intérieurs
Base para hornear 1 extraíble + 2 cajones interiores
Kochfeldunterschrank 1 Auszug + 2 Innenschubladen

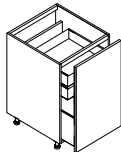

P/D	L/W	CODICE	0	1	2	3	4	5	6	7	8	9	10
57	45	KBC520780454	427	472	488	526	543	591	623	648	800	958	1.008
57	60	KBC520780604	449	492	511	561	579	625	663	720	889	1.064	1.114
57	75	KBC520780754	465	507	534	593	617	671	697	794	979	1.172	1.222
67	45	KBC520780457	558	603	617	657	666	729	761	778	961	1.151	1.201
67	60	KBC520780607	578	622	639	691	701	765	796	849	1.050	1.258	1.308
67	75	KBC520780757	600	640	667	727	745	815	830	928	1.145	1.372	1.422

Base cottura cappa integrata 2 cestoni

Integrated hood 2 baskets
Base cuisson hotte intégrée 2 paniers
Base para hornear con campana integrada 2 cestas
Kochfeldunterschrank mit Integrierte Dunstabzugshaube 2 Schubkasten

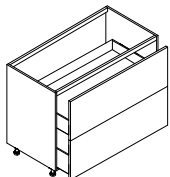

P/D	L/W	CODICE	0	1	2	3	4	5	6	7	8	9	10
57	90	KBC550780904	440	519	530	603	640	723	752	822	1.004	1.200	1.160
57	105	KBC550781054	508	577	617	693	720	816	843	933	1.141	1.365	1.418
57	120	KBC550781204	606	661	714	803	841	912	984	1.073	1.306	1.563	1.613
67	90	KBC550780907	522	599	610	684	720	807	832	905	1.088	1.301	1.351
67	105	KBC550781057	591	655	696	772	798	901	924	1.013	1.222	1.464	1.514
67	120	KBC550781207	676	729	786	874	911	984	1.051	1.141	1.397	1.671	1.721

BASI CON MANIGLIA PIANO COTTURA E FORNO

H. 78

Hob base unit for oven with handle
Bases cuisson et four avec poignée
Bases para hornear con horno con tirador
Kochfeld/Backofen Unterschränke mit Griff

Base cottura cappa integrata 1 frontale fisso + 2 ante

Integrated hood 1 fixed front + 2 hinged doors
Base cuisson hotte intégrée 1 façade fixe + 2 portes
Base para hornear con campana integrada 1 frente fijo + 1 cajón + 2 puertas
Kochfeldunterschrank mit Integrierte Dunstabzugshaube 1 feste Front + 2 Türen

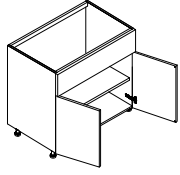

P/D	L/W	CODICE	0	1	2	3	4	5	6	7	8	9	10
57	90	KBC320780904	404	480	494	568	600	655	690	784	984	1.199	1.249
57	120	KBC320781204	442	519	533	607	639	694	728	823	1.024	1.239	1.289
67	90	KBC320780907	475	526	539	597	631	695	721	768	962	1.173	1.223
67	120	KBC320781207	514	565	578	635	669	733	760	807	1.002	1.213	1.263

Base cottura cappa integrata 1 frontale fisso + 1 cassetto + 1 cestone

Integrated hood base unit 1 fixed front + 1 drawer + 1 basket
Base cuisson hotte intégrée 1 façade fixe + 1 tiroir + 1 panier
Base para hornear con campana integrada 1 frente fijo + 1 cajón + 1 cesta
Integrierte Dunstabzugshaube Kochfeldunterschrank 1 feste Front + 1 Schublade + 1 Schubkast

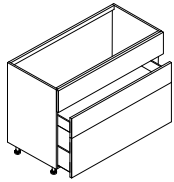

P/D	L/W	CODICE	0	1	2	3	4	5	6	7	8	9	10
57	90	KBC360780904	484	558	597	677	708	760	809	905	1.112	1.332	1.382
57	105	KBC360781054	518	580	629	723	746	815	864	989	1.215	1.454	1.504
57	120	KBC360781204	571	615	674	771	803	792	937	1.068	1.312	1.571	1.621
67	90	KBC360780907	618	692	728	811	840	895	943	1.040	1.278	1.531	1.581
67	105	KBC360781057	652	715	760	860	880	950	997	1.121	1.382	1.655	1.705
67	120	KBC360781207	689	735	891	890	922	1.007	1.056	1.188	1.462	1.752	1.802

Base cottura e forno H. 60 con 2 frontali fissi

Hob base unit for H 60 oven with 2 fixed fronts
Base cuisson et four H 60 2 façades fixes
Base para hornear con horno H.60 con 2 frentes fijos
H 60 Kochfeld und Backofenunterschrank mit 2 festen Fronten

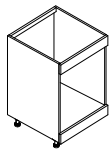

P/D	L/W	CODICE	0	1	2	3	4	5	6	7	8	9	10
57	60	KB0300780604	140	166	170	194	204	219	235	255	295	355	385
□	57	KB0300780754	152	178	181	212	218	230	249	271	306	367	442
67	60	KB0300780607	155	181	185	210	219	235	250	271	311	371	401
□	67	KB0300780757	168	194	197	228	234	245	255	286	322	383	458

□ **forno L 75 cm** | oven L 75 cm | four L 75 cm | horno L 75 cm | backofen B 75 cm

Basi con maniglia
Base units with handle

Basi con gola
Base units with groove

Colonne
Tall units

Pensili
Wall units

Elementi speciali
Special elements

Maniglie gole zoccoli
Handles grooves plinth

Illuminazione
Lighting

Accessori
Accessories

Componenti e meccanismi
Components e mechanism

BASI CON MANIGLIA PIANO COTTURA E FORNO

H. 78

Hob base unit for oven with handle
Bases cuisson et four avec poignée
Bases para hornear con horno con tirador
Kochfeld/Backofen Unterschränke mit Griff

Base cottura e forno H. 46 con 1 frontale fisso + 1 cassetto

Hob base unit for H 46 oven with 1 fixed front + 1 drawer
Base cuisson et four H 46 1 façade fixe + 1 tiroir
Base para hornear con horno H.46 con 1 frente fijo + 1 cajón
H 46 Kochfeld und Backofenunterschränk mit 1 festen Front + 1 Schublade

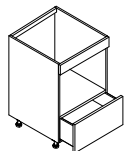

P/D	L/W	CODICE	0	1	2	3	4	5	6	7	8	9	10
57	60	KB0330780604	275	316	340	381	404	438	456	520	625	749	799
67	60	KB0330780607	331	363	393	430	453	500	518	574	678	814	864

Base cottura e forno H. 48 con 1 frontale fisso + 1 cassetto

Hob base unit for H 48 oven with 1 fixed front + 1 drawer
Base cuisson et four H 48 1 façade fixe + 1 tiroir
Base para hornear con horno H.48 con 1 frente fijo + 1 cajón
H 48 Kochfeld und Backofenunterschränk mit 1 festen Front + 1 Schublade

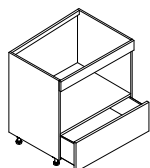

P/D	L/W	CODICE	0	1	2	3	4	5	6	7	8	9	10
57	90	KB0330780904	324	365	389	430	452	487	504	568	675	799	849
67	90	KB0330780907	379	411	441	478	501	548	566	623	728	864	914

Protezione sotto piano induzione

Protection under induction hob
Protection sous la table de cuisson à induction
Protección bajo placa de inducción
Schutz Induktionskochfeldern

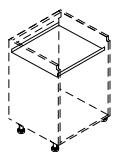

P/D	L/W	CODICE	0	1	2	3	4	5	6	7	8	9	10
50	60	KVP010564936	50	-	-	-	-	-	-	-	-	-	-
50	75	KVP010714936	63	-	-	-	-	-	-	-	-	-	-
50	90	KVP010864936	67	-	-	-	-	-	-	-	-	-	-
50	105	KVP011014936	74	-	-	-	-	-	-	-	-	-	-
50	120	KVP011164936	81	-	-	-	-	-	-	-	-	-	-

BASI CON MANIGLIA LAVELLO

H. 78

Sink base unit with handle
Bases sous évier avec poignée
Bases fregadero con tirador
Spülenunterschranke mit Griff

Base livello 1 anta

Sink base unit 1 door
Base sous évier 1 porte
Base fregadero 1 puerta
Spülenunterschrank 1 Tür

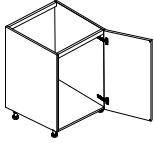

P/D	L/W	CODICE	0	1	2	3	4	5	6	7	8	9	10
57	45	KBL010780454	153	190	208	246	270	279	296	331	408	489	510
57	60	KBL010780604	165	200	222	272	302	318	340	388	482	578	613
57	75	KBL010780754	183	219	251	312	349	372	405	469	585	700	725
67	45	KBL010780457	161	200	215	254	278	283	304	339	420	505	519
67	60	KBL010780607	177	210	233	279	309	312	350	400	493	592	623
67	75	KBL010780757	202	234	262	320	356	361	418	484	596	715	736

Base livello 2 ante

Sink base unit 2 door
Base sous évier 2 portes
Base fregadero de 2 puertas
2-türiger Spülenunterschrank

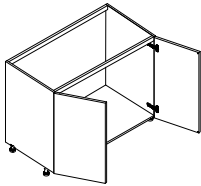

P/D	L/W	CODICE	0	1	2	3	4	5	6	7	8	9	10
57	60	KBL020780604	186	236	252	312	344	365	381	443	549	658	744
57	90	KBL020780904	221	271	304	379	427	447	482	557	687	824	957
57	120	KBL020781204	259	310	355	450	507	530	595	692	857	1.027	1.167
67	60	KBL020780607	196	247	262	321	353	372	390	451	559	672	754
67	90	KBL020780907	235	283	318	393	441	459	499	569	705	845	968
67	120	KBL020781207	274	323	370	466	521	544	608	705	872	1.045	1.179

Base livello 2 cestoni

Sink base unit with 2 deep drawers
Base sous évier 2 paniers
Base fregadero de 2 cestas
2-Schubkasten-Spülenunterschrank

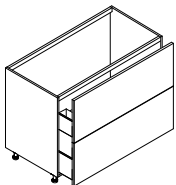

P/D	L/W	CODICE	0	1	2	3	4	5	6	7	8	9	10
57	75	KBL540780754	501	523	534	606	632	682	717	806	986	1.184	1.234
57	90	KBL540780904	554	577	595	657	702	763	798	905	1.110	1.332	1.382
57	105	KBL540781054	636	661	674	757	805	876	910	1.042	1.276	1.529	1.579
57	120	KBL540781204	703	729	766	857	909	967	1.034	1.180	1.441	1.729	1.779
67	75	KBL540780757	598	626	636	707	733	780	819	913	1.123	1.347	1.397
67	90	KBL540780907	652	678	695	755	799	859	897	1.003	1.229	1.476	1.526
67	105	KBL540781057	722	748	759	839	889	959	991	1.125	1.380	1.658	1.708
67	120	KBL540781207	774	799	836	926	978	1.034	1.105	1.247	1.531	1.839	1.889

Basi con maniglia
Base units with handle

Basi con gola
Base units with groove

Colonne
Tall units

Pensili
Wall units

Elementi speciali
Special elements

Maniglie gole zoccoli
Handles grooves plinth

Illuminazione
Lighting

Accessori
Accessories

Componenti e meccanismi
Components e mechanism

BASI CON MANIGLIA LAVELLO

H. 78

Sink base unit with handle
Bases sous évier avec poignée
Bases fregadero con tirador
Spülenunterschranke mit Griff

Base lavello 1 frontale fisso + 1 cestone

Sink base unit 1 fixed front + 1 deep drawer
Base sous évier 1 façade fixe + 1 panier
Base fregadero 1 frente fijo + 1 cajón
Spülenunterschrank 1 feste Front + 1 Schublade

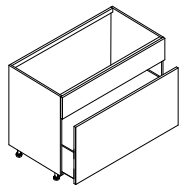

P/D	L/W	CODICE	0	1	2	3	4	5	6	7	8	9	10
57	75	KBL340780754	329	340	355	407	436	448	490	567	701	842	970
57	90	KBL340780904	346	362	381	443	472	491	542	631	779	934	1.098
57	105	KBL340781054	399	415	439	510	543	564	624	726	895	1.075	1.228
57	120	KBL340781204	459	477	505	588	626	649	718	834	1.029	1.237	1.358
67	75	KBL340780757	380	398	407	460	485	499	536	620	763	916	992
67	90	KBL340780907	397	417	432	495	521	537	589	684	841	1.010	1.122
67	105	KBL340781057	436	460	474	544	572	593	647	754	924	1.150	1.253
67	120	KBL340781207	480	506	523	599	631	652	712	827	1.017	1.264	1.385

Base lavello 1 frontale fisso + 1 cassetto + 1 cestone

Sink base unit 1 fixed front + 1 drawer + 1 deep drawer
Base sous évier 1 façade fixe + 1 tiroir + 1 panier
Base fregadero 1 frente fijo + 1 cajón + 1 cajón hondo
Spülenunterschrank 1 feste Front + 1 Schublade + 1 tiefer Auszug

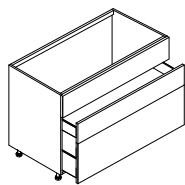

P/D	L/W	CODICE	0	1	2	3	4	5	6	7	8	9	10
57	75	KBL360780754	501	523	534	606	632	682	717	806	986	1.184	1.234
57	90	KBL360780904	554	577	595	657	702	763	798	905	1.110	1.332	1.382
57	105	KBL360781054	636	661	674	757	805	876	910	1.042	1.276	1.529	1.579
57	120	KBL360781204	703	729	766	857	909	967	1.034	1.180	1.441	1.729	1.779
67	75	KBL360780757	598	626	636	707	733	780	819	913	1.123	1.347	1.397
67	90	KBL360780907	652	678	695	755	799	859	897	1.003	1.229	1.476	1.526
67	105	KBL360781057	722	748	759	839	889	959	991	1.125	1.380	1.658	1.708
67	120	KBL360781207	774	799	836	926	978	1.034	1.105	1.247	1.531	1.839	1.889

Base lavello 1 frontale fisso + 1 anta

Sink base unit 1 fixed front + 1 door
Base sous évier 1 façade fixe + 1 porte
Base fregadero 1 frente fijo + 1 puerta
Spülenunterschrank 1 feste Front + 1 Tür

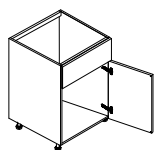

P/D	L/W	CODICE	0	1	2	3	4	5	6	7	8	9	10
57	45	KBL310780454	153	190	208	246	270	274	296	331	408	489	582
57	60	KBL310780604	165	200	222	272	302	303	340	388	482	578	706
67	45	KBL310780457	161	200	215	254	278	283	304	339	420	505	591
67	60	KBL310780607	177	210	233	279	309	312	350	400	493	592	716

BASI CON MANIGLIA LEVELLO

H. 78

Sink base unit with handle
Bases sous évier avec poignée
Bases fregadero con tirador
Spülenunterschranke mit Griff

Base livello 1 frontale fisso + 2 ante

Sink base unit 1 fixed front + 2 doors
Base sous évier 1 façade fixe + 2 portes
Base fregadero 1 frente fijo + 2 puertas
Spülenunterschrank 1 feste Front + 2 Türen

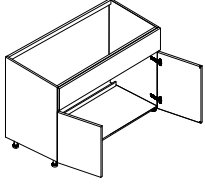

P/D	L/W	CODICE	0	1	2	3	4	5	6	7	8	9	10
57	90	KBL320780904	221	271	304	379	427	447	482	557	687	824	1.062
57	120	KBL320781204	259	310	355	450	507	530	595	692	857	1.027	1.313
67	90	KBL320780907	235	283	318	393	441	459	499	569	705	845	1.073
67	120	KBL320781207	274	323	370	466	521	544	608	705	872	1.045	1.326

Base livello 1 estraibile

Sink base unit 1 pull-out
Base sous évier 1 extractible
Base fregadero 1 extraíble
Spülenunterschrank 1 Auszug

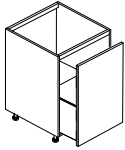

P/D	L/W	CODICE	0	1	2	3	4	5	6	7	8	9	10
57	45	KBL500780454	277	286	297	319	345	373	395	456	563	676	716
57	60	KBL500780604	296	305	313	353	380	406	436	503	624	748	788
57	75	KBL500780754	312	323	339	387	414	448	490	567	701	842	882
67	45	KBL500780457	330	340	346	371	396	427	447	506	629	754	794
67	60	KBL500780607	346	359	365	404	430	459	484	555	686	823	863
67	75	KBL500780757	363	378	387	437	463	499	536	620	763	916	956

Optional copertura livello in finitura scocca (sp. 1,8 cm H. 13,3 cm)

Optional sink cover in shell finish (1.8 cm thick H 13.3 cm)
Option : couvercle d'évier en finition corps (1,8 cm d'épaisseur H 13,3 cm)
Optional cubierta para fregadero acabado como estructura (1,8 cm de grosor H 13,3 cm)
Optionale Waschbeckenabdeckung in Korpusausführung (1,8 cm dick, H 13,3 cm)

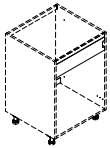

L/W	CODICE	0	1	2	3	4	5	6	7	8	9	10
41,3	JPE0101304118	49	49	49	49	49	49	49	49	49	49	49
56,3	JPE0101305618	49	49	49	49	49	49	49	49	49	49	49
71,3	JPE0101307118	49	49	49	49	49	49	49	49	49	49	49
86,3	JPE0101308618	49	49	49	49	49	49	49	49	49	49	49
101,3	JPE0101310118	49	49	49	49	49	49	49	49	49	49	49
116,3	JPE0101311618	49	49	49	49	49	49	49	49	49	49	49

Basi con maniglia
Base units with handle

Basi con gola
Base units with groove

Colonne
Tall units

Pensili
Wall units

Elementi speciali
Special elements

Maniglie gole zoccoli
Handles grooves plinth

Illuminazione
Lighting

Accessori
Accessories

Componenti e meccanismi
Components e mechanism

BASI CON MANIGLIA ANGOLO

H. 78

Corner base unit with handle
Bases d'angle avec poignéE
Bases ángulo con tirador
Unterschränke mit Eckgriff

Montante per angolo cieco

Blind corner upright
Montant de l'angle mort
Regleta para ángulo ciego
Eckblende



P/D	L/W	CODICE	0	1	2	3	4	5	6	7	8	9	10
6,5	6,5	KBA90078007C	54	55	56	77	85	96	117	122	153	182	232

Base angolo 1 anta + 1 ripiano

Corner base unit 1 door + 1 shelf
Base d'angle 1 porte + 1 étagère
Base ángulo 1 puerta + 1 balda
Eckschrank 1 Tür + 1 Fachboden

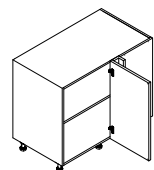

	P/D	L/W	CODICE	0	1	2	3	4	5	6	7	8	9	10
●	42	95	KBA010780951D/S	236	283	323	410	453	480	501	707	729	887	937
○	42	110	KBA010781101D/S	273	320	360	447	490	517	537	744	767	925	975
△	42	125	KBA010781251D/S	275	322	371	464	512	551	577	799	824	992	1.042
●	65	95	KBA010780954D/S	255	303	342	430	472	500	520	727	749	907	957
○	65	110	KBA010781104D/S	292	340	379	467	509	536	557	637	787	945	995
△	65	125	KBA010781254D/S	294	341	390	483	532	570	597	682	844	1.012	1.062
●	75	105	KBA010781057D/S	330	379	448	589	654	724	755	1.067	1.100	1.327	1.377
○	75	120	KBA010781207D/S	367	416	485	626	691	760	792	921	1.138	1.365	1.415
△	75	135	KBA010781357D/S	371	420	493	643	714	793	831	964	1.194	1.433	1.483

- **scocca da 75 cm** | 75 cm body | structure de 75 cm | estructura de 75 cm | 75 cm Korpus
- **scocca da 90 cm** | 90 cm body | structure de 90 cm | estructura de 90 cm | 90 cm Korpus
- △ **scocca da 120 cm** | 120 cm body | structure de 120 cm | estructura de 120 cm | 120 cm Korpus

Base angolo 1 anta con meccanismo Linea Pro Sige

Corner base unit 1 door with Linea Pro mechanism
Base d'angle 1 porte avec mécanisme Linea Pro Sige
Base ángulo 1 puerta con mecanismo Linea Pro Sige
Eckschrank 1 Tür mit Mechanismus Linea Pro Sige

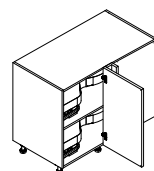

	P/D	L/W	CODICE	0	1	2	3	4	5	6	7	8	9	10
○	65	110	KBA760781104D/S	757	803	820	903	948	993	1.012	1.081	1.244	1.400	1.450
▲	65	125	KBA760781254D/S	816	865	885	979	1.023	1.083	1.110	1.180	1.357	1.526	1.576
○	75	120	KBA760781207D/S	766	813	829	913	957	1.003	1.021	1.090	1.254	1.410	1.460
▲	75	135	KBA760781357D/S	890	943	964	1.109	1.177	1.307	1.344	1.464	1.708	1.947	1.997

- **scocca da 90 cm** | 90 cm body | structure de 90 cm | estructura de 90 cm | 90 cm Korpus
- ▲ **scocca da 105 cm** | 105 cm body | structure de 105 cm | estructura de 105 cm | 105 cm Korpus

Maggiorazione per meccanismo Linea Pure Kesseböhmer PUNTI 269

Mechanism Pure Kesseböhmer Line | Supplément pour le mécanisme Linea Pure Kesseböhmer | Recargo para mecanismo Linea Pure Kesseböhmer | Aufpreis für Mechanismus Pure Kesseböhmer Line

BASI CON MANIGLIA ANGOLO

H. 78

Corner base unit with handle
Bases d'angle avec poignéE
Bases ángulo con tirador
Unterschranke mit Eckgriff

Base angolo 2 ante (su fianchi) + 1 ripiano

Corner base unit 2 doors (on sides) + 1 shelf
Base d'angle 2 portes (sur les côtés) + 1 étagère
Base ángulo 2 puertas (laterales) + 1 balda
Eckschrank 2 Türen (an den Seiten) + 1 Regal

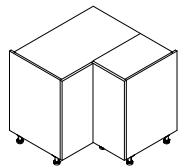

P/D	L/W	CODICE	0	1	2	3	4	5	6	7	8	9	10
95	95	KBA02078095A	430	463	474	546	569	609	629	751	929	1.114	1.164
105	105	KBA02078105B	464	471	517	587	612	646	671	764	946	1.134	1.184

Base livello angolo 1 anta

Corner sink base unit 1 door
Base sous evier d'angle 1 porte
Base fregadero ángulo 1 puerta
Eckspülenunterschrank 1 Tür

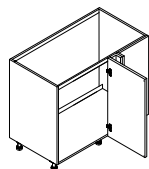

	P/D	L/W	CODICE	0	1	2	3	4	5	6	7	8	9	10
●	65	95	KBB010780954D/S	272	305	321	380	414	442	460	536	666	792	902
○	65	110	KBB010781104D/S	281	314	331	390	424	452	469	546	676	812	912
△	65	125	KBB010781254D/S	287	321	343	410	448	478	511	588	727	874	974
●	75	105	KBB010781057D/S	277	311	328	388	423	453	470	549	680	818	917
○	75	120	KBB010781207D/S	287	321	338	398	433	463	480	559	690	827	927
△	75	135	KBB010781357D/S	294	329	350	420	458	490	524	600	743	890	990

- **scocca da 75 cm** | 75 cm body | structure de 75 cm | estructura de 75 cm | 75 cm Korpus
- **scocca da 90 cm** | 90 cm body | structure de 90 cm | estructura de 90 cm | 90 cm Korpus
- △ **scocca da 120 cm** | 120 cm body | structure de 120 cm | estructura de 120 cm | 120 cm Korpus

Basi con maniglia
Base units with handle

Basi con gola
Base units with groove

Colonne
Tall units

Pensili
Wall units

Elementi speciali
Special elements

Maniglie gole zoccoli
Handles grooves plinth

Illuminazione
Lighting

Accessori
Accessories

Componenti e meccanismi
Components e mechanism

ANTE E STRUTTURE PER ELETTRODOMESTICI

H. 78

Doors and frames for household appliances
Portes et structures pour électroménagers
Puertas y estructuras para electrodomésticos
Türen und Rahmen für Elektrogeräte

Anta per lavastoviglie con comandi a scomparsa totale (sliding)

Door for dishwashers with fully concealed controls (sliding)
Porte pour lave-vaisselle à commandes entièrement dissimulées (coulissante)
Puerta para lavavajillas con mandos totalmente ocultos (corredera)
Tür für Geschirrspüler mit vollständig verdeckten Bedienelementen (Schiebetür)

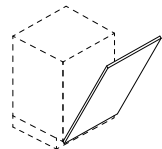

L/W	CODICE	0	1	2	3	4	5	6	7	8	9	10
45	KAL01078045	71	79	99	134	153	191	218	230	312	367	420
60	KAL01078060	73	81	108	150	178	226	262	264	375	444	511

Anta per lavastoviglie con comandi a scomparsa totale (con fisso inferiore)

Door for dishwashers with fully concealed controls (with lower fixed)
Porte pour lave-vaisselle à commandes entièrement dissimulées (avec fixe inférieur)
Puerta para lavavajillas con mandos totalmente ocultos (con fijo inferior)
Tür für Geschirrspüler mit vollständig verdeckten Bedienelementen (mit unterer Befestigung)

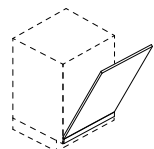

L/W	CODICE	0	1	2	3	4	5	6	7	8	9	10
45	KAL03078045	79	85	105	140	161	177	202	237	286	338	461
60	KAL03078060	92	102	127	181	209	236	286	331	403	478	564

Anta per frigo o congelatore autoportanti

Self-supporting refrigerator or freezer door
Porte frigo ou congélateur autoportante
Puerta de frigorífico o congelador autoportante
Selbsttragende Kühl- oder Gefrierschranktür

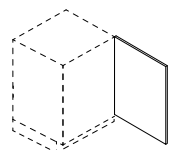

L/W	CODICE	0	1	2	3	4	5	6	7	8	9	10
60	KAF01078060	73	81	108	150	178	226	262	264	375	444	511

ANTE E STRUTTURE PER ELETTRODOMESTICI

H. 78

Doors and frames for household appliances
Portes et structures pour électroménagers
Puertas y estructuras para electrodomésticos
Türen und Rahmen für Elektrogeräte

Struttura per frigorifero o congelatore traino

Frame for towing refrigerator or freezer
Cadre pour le remorquage d'un réfrigérateur ou d'un congélateur
Estructura para nevera o freezer
Gestell zum Ziehen eines Kühl- oder Gefrierschranks

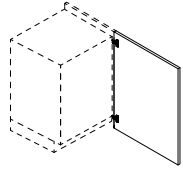

L/W	CODICE	0	1	2	3	4	5	6	7	8	9	10
60	KAF03078060	105	113	146	194	225	245	280	327	393	461	519

Anta per lavatrice integrale

Door for integral washing machine
Porte pour lave-linge intégré
Puerta para lavadora integral
Tür für integrierte Waschmaschine

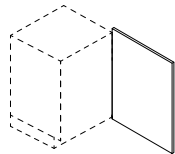

L/W	CODICE	0	1	2	3	4	5	6	7	8	9	10
60	KAL05078060	73	81	108	150	178	226	262	264	375	444	511

Distanziale per fissaggio fianco con lavastoviglie a fine composizione

Spacer for fixing the side with dishwasher at the end of the composition
Entretoise pour la fixation du panneau latéral avec lave-vaisselle à la fin de la composition
Distanciador para fijar el lado con lavavajillas al final de la composición
Abstandshalter zur Befestigung der Seitenwand mit Geschirrspüler am Ende der Komposition

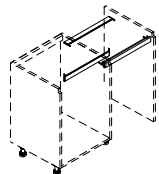

L/W	CODICE	0	1	2	3	4	5	6	7	8	9	10
45	09K0100004	27	-	-	-	-	-	-	-	-	-	-
60	09K0100005	29	-	-	-	-	-	-	-	-	-	-

Basi con maniglia
Base units with handle

Basi con gola
Base units with groove

Colonne
Tall units

Pensili
Wall units

Elementi speciali
Special elements

Maniglie gole zoccoli
Handles grooves plinth

Illuminazione
Lighting

Accessori
Accessories

Componenti e meccanismi
Components e mechanism

ANTE E STRUTTURE PER ELETTRODOMESTICI

H. 78

Doors and frames for household appliances
Portes et structures pour électroménagers
Puertas y estructuras para electrodomésticos
Türen und Rahmen für Elektrogeräte

Base per frigorifero da incasso

Base unit for built-in refrigerator
Base pour réfrigérateur encastré
Base fregadero empotrado
Unterschrank für Einbaukühlschrank

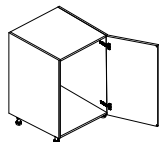

P/D	L/W	CODICE	0	1	2	3	4	5	6	7	8	9	10
57	60	KAF050780604	149	177	182	209	216	235	249	274	330	396	446
67	60	KAF050780607	164	190	192	227	233	245	264	287	343	412	462

Base per lavastoviglie rialzata + cestone

Raised dishwasher base + 1 deep drawer
Base surélevée lave-vaisselle surélevée + panier
Base lavavajillas elevada + cesta
Erhöhter Geschirrspülerboden Unterschrank + Schubkast

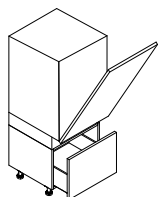

P/D	L/W	CODICE	0	1	2	3	4	5	6	7	8	9	10
57	60	KAL110780604	277	307	327	375	383	419	474	503	646	852	902
67	60	KAL110780607	297	326	346	395	403	438	494	523	666	872	922

BASI CON GOLA

Base units with groove
Bases avec rainure
Bases con uñero
Unterschränke mit Griffleiste

H. 40,5	P. 63
<ul style="list-style-type: none"> BASI Base units Bases Bases Unterschränke 	P. 63
H. 48,5	P. 64
<ul style="list-style-type: none"> BASI Base units Bases Bases Unterschränke 	P. 64
H. 61,5	P. 65
<ul style="list-style-type: none"> BASI base units bases bases Unterschränke BASI PIANO COTTURA hob base units Bases cuisson bases para hornear Kochfeld Unterschränke BASI LAVELLO sink base units Bases sous évier bases fregadero Spülenunterschrank 	P. 65 P. 66 P. 67
H. 81	P. 68
<ul style="list-style-type: none"> BASI base units bases bases Unterschränke BASI PIANO COTTURA E FORNO hob base units for oven Bases cuisson et four bases para hornear con horno Kochfeld/Backofen Unterschränke BASI LAVELLO sink base units Bases sous évier bases fregadero Spülenunterschrank BASI ANGOLO corner base units bases d'angle bases ángulo eckunterschranke ANTE E STRUTTURE PER ELETTRODOMESTICI doors and frames for household appliances portes et structures pour électroménagers puertas y estructuras para electrodomésticos türen und Rahmen für Elektrogeräte 	P. 68 P. 75 P. 81 P. 84 P. 86

Basi con maniglia
Base units with handle

Basi con gola
Base units with groove

Colonne
Tall units

Pensili
Wall units

Elementi speciali
Special elements

Maniglie gole zoccoli
Handles grooves plinth

Illuminazione
Lighting

Accessori
Accessories

Componenti e meccanismi
Components e mechanism

MAGGIORAZIONI BASI

Basic surcharges
Suppléments de base
Recargos básicos
Grundlegende Zuschläge

Consulta l'elenco completo delle maggiorazioni a pag. 30

See the full list of surcharges on page 30

Voir la liste complète des suppléments à la page 30

Consulte la lista completa de recargos a la página 30

Siehe die vollständige Liste der Zuschläge auf Seite 30

MAGGIORAZIONI ENHANCEMENTS SUPPLÉMENTS RECARGOS AUFPREISEN	PUNTI POINTS POINTS PUNTOS PUNKTE
MECCANISMO ARENA STYLE PER ESTRAIBILE L. 15 KESSEBOHMER Arena Style mechanism for pull-out L. 15 Kessebohmer Pour le mécanisme Arena Style pour l'extraction L. 15 Kessebohmer Para mecanismo Arena Style para extracción L. 15 Kessebohmer Für Arena Style Mechanismus für Auszug L. 15 Kessebohmer	95
MECCANISMO LINEA PURE PER ESTRAIBILE L. 30 KESSEBOHMER For Linea Pure mechanism for pull-out L. 30 Kessebohmer Pour mécanisme Pure Line pour pull-out L. 30 Kessebohmer Para mecanismo Pure Line para extracción L. 30 Kessebohmer Für Mechanik Pure Line für Auszug L. 30 Kessebohmer	119
MECCANISMO LINEA PURE PER BASE ANGOLO KESSEBOHMER For Linea Pure mechanism for Kessebohmer corner base Pour mécanisme Pure Line pour base d'angle Kessebohmer Para mecanismo Linea Pure para base de esquina Kessebohmer Für Mechanik Pure Line für Kessebohmer Ecksocket	269

BASI CON GOLLA

Base units with groove
Bases avec rainure
Bases con uñero
Unterschranke mit Griffleiste

H. 40,5

Base 1 cestone

Base unit 1 deep drawer
Base 1 panier
Base 1 cajón
Unterschrank 1 Schublade

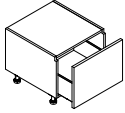

P/D	L/W	CODICE	0	1	2	3	4	5	6	7	8	9	10
57	45	KGN500400454	296	307	319	341	359	365	378	412	506	606	706
57	60	KGN500400604	314	329	338	365	387	396	406	444	545	655	755
57	75	KGN500400754	337	355	361	395	418	432	448	492	601	721	821
57	90	KGN500400904	353	390	402	414	438	464	478	525	645	773	873
57	105	KGN500401054	390	406	418	460	482	514	536	583	719	861	961
57	120	KGN500401204	434	452	466	507	535	563	599	646	789	947	1.047
67	45	KGN500400457	344	359	373	397	409	432	446	491	590	709	809
67	60	KGN500400607	365	378	393	418	436	464	474	526	632	759	859
67	75	KGN500400757	391	406	418	452	476	506	524	577	695	834	934
67	90	KGN500400907	407	417	438	474	492	517	543	611	739	886	986
67	105	KGN500401057	443	450	477	520	536	568	605	677	817	981	1.081
67	120	KGN500401207	471	477	509	553	572	601	638	726	876	1.051	1.151

Base 2 cassetti

Base unit 2-drawers
Base 2 tiroirs
Base de 2 cajones
2-Schubladen-Unterschrank

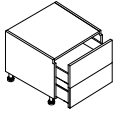

Con fondo rientrato per apertura cassetto inferiore
With recessed bottom for bottom drawer opening
Avec fond en retrait pour l'ouverture du tiroir inférieur
Con fondo entrante para apertura cajón inferior
Mit vertieftem Boden für untere Schubladenöffnung

P/D	L/W	CODICE	0	1	2	3	4	5	6	7	8	9	10
57	45	KGN600400454	364	375	387	409	427	433	446	480	576	676	776
57	60	KGN600400604	382	397	405	433	455	464	474	512	615	725	825
57	75	KGN600400754	404	423	429	463	486	500	516	560	671	791	891
57	90	KGN600400904	421	458	469	482	506	532	546	593	715	843	943
57	105	KGN600401054	458	474	486	528	550	582	604	651	789	931	1.031
57	120	KGN600401204	501	520	534	575	603	631	667	714	859	1.017	1.117
67	45	KGN600400457	412	427	441	465	477	500	514	559	660	779	879
67	60	KGN600400607	433	446	461	486	503	532	542	594	702	829	929
67	75	KGN600400757	459	474	486	520	544	574	592	645	765	904	1.004
67	90	KGN600400907	475	485	506	542	560	585	611	679	809	956	1.056
67	105	KGN600401057	511	518	545	588	604	636	673	745	887	1.051	1.151
67	120	KGN600401207	539	545	577	621	640	669	706	793	946	1.121	1.221

Basi con maniglia
Base units with handle

Basi con gola
Base units with groove

Colonne
Tall units

Pensili
Wall units

Elementi speciali
Special elements

Maniglie gole zoccoli
Handles grooves plinth

Illuminazione
Lighting

Accessori
Accessories

Componenti e meccanismi
Components e mechanism

BASI CON GOLA

Base units with groove
Bases avec rainure
Bases con uñero
Unterschranke mit Griffleiste

H. 48,5

Base 1 anta

Base unit with 1 hinged door
Base 1 porte
Base 1 puerta
Unterschrank 1 Tür

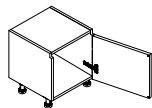

P/D	L/W	CODICE	0	1	2	3	4	5	6	7	8	9	10
34	45	KGN010480451	118	150	155	168	181	184	190	216	269	321	421
34	60	KGN010480601	125	153	156	178	186	194	204	239	299	359	459
57	45	KGN010480454	126	165	184	201	223	233	252	307	380	463	563
57	60	KGN010480604	146	178	194	227	252	268	293	349	435	524	624
67	45	KGN010480457	138	177	196	210	235	244	264	317	390	450	550
67	60	KGN010480607	157	189	204	237	262	279	305	361	447	536	636

Base 2 ante

Base unit with 2 hinged doors
Base 2 portes
Base de 2 puertas
2-türiger Unterschrank

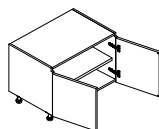

P/D	L/W	CODICE	0	1	2	3	4	5	6	7	8	9	10
57	90	KGN020480904	199	246	287	341	386	406	447	552	687	827	927
67	90	KGN020480907	209	260	299	353	406	419	456	561	699	841	941

Base 1 cestone

Base unit 1 deep drawer
Base 1 panier
Base 1 cajón
Unterschrank 1 Schublade

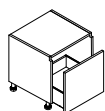

P/D	L/W	CODICE	0	1	2	3	4	5	6	7	8	9	10
57	45	KGN500480454	307	319	331	353	371	376	390	424	518	618	718
57	60	KGN500480604	326	340	349	376	399	407	418	456	557	667	767
57	75	KGN500480754	348	367	372	406	430	443	460	503	613	733	833
57	90	KGN500480904	365	402	413	426	450	475	490	536	657	785	885
57	105	KGN500481054	402	418	430	471	494	526	548	595	731	873	973
57	120	KGN500481204	445	464	477	519	547	574	611	658	801	959	1.059
67	45	KGN500480457	356	371	385	408	421	443	458	502	602	721	821
67	60	KGN500480607	376	390	404	430	447	475	486	537	644	771	871
67	75	KGN500480757	403	418	430	464	488	518	535	589	707	846	946
67	90	KGN500480907	419	429	450	486	503	529	555	623	751	898	998
67	105	KGN500481057	455	462	489	532	548	580	617	689	829	993	1.093
67	120	KGN500481207	483	489	521	565	584	613	650	737	888	1.063	1.163

BASI CON GOLA

Base units with groove
Bases avec rainure
Bases con uñero
Unterschranke mit Griffleiste

H. 61,5

Base 1 anta

Base unit with 1 hinged door
Base 1 porte
Base 1 puerta
Unterschrank 1 Tür

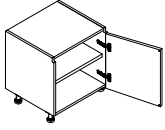

P/D	L/W	CODICE	0	1	2	3	4	5	6	7	8	9	10
34	45	KGNO10610451	128	165	182	201	224	234	253	307	383	463	563
34	60	KGNO10610601	146	178	199	227	252	268	293	350	435	524	624
57	45	KGNO10610454	140	177	194	212	236	245	265	319	395	475	575
57	60	KGNO10610604	157	189	210	239	264	279	305	362	447	536	636
67	45	KGNO10610457	147	182	201	220	242	253	271	327	404	484	584
67	60	KGNO10610607	165	199	237	244	270	287	311	369	455	546	646

Base 2 ante

Base unit with 2 hinged doors
Base 2 portes
Base de 2 puertas
2-türiger Unterschrank

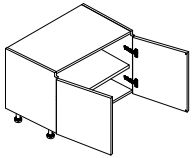

P/D	L/W	CODICE	0	1	2	3	4	5	6	7	8	9	10
34	90	KGNO20610901	199	246	287	341	386	406	447	552	687	827	927
57	90	KGNO20610904	210	258	299	353	398	418	459	564	699	839	939
67	90	KGNO20610907	220	272	310	365	408	431	468	572	711	853	953

Base 1 estraibile + 1 cassetto interno

Base unit 1 pull-out deep drawer + 1 internal drawer
Base 1 extractible + 1 tiroir intérieur
Base 1 extraíble + 1 cajón interior
Unterschrank 1 Auszug + 1 Innenschubladen

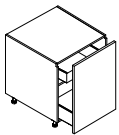

P/D	L/W	CODICE	0	1	2	3	4	5	6	7	8	9	10
57	45	KGN510610454	331	359	391	426	448	466	490	547	677	813	912
57	60	KGN510610604	348	391	415	460	489	503	541	621	766	920	1.020
57	75	KGN510610754	406	418	442	495	520	540	589	674	839	1.004	1.104
57	90	KGN510610904	460	480	521	568	601	622	671	760	942	1.130	1.230
57	105	KGN510611054	485	502	544	601	629	652	695	803	977	1.174	1.274
57	120	KGN510611204	534	554	600	668	690	712	772	901	1.112	1.333	1.433
67	45	KGN510610457	417	443	477	514	535	555	574	635	787	945	1.045
67	60	KGN510610607	437	477	502	547	572	594	631	706	877	1.052	1.152
67	75	KGN510610757	499	510	534	588	609	632	680	767	950	1.141	1.241
67	90	KGN510610907	553	579	619	669	700	722	769	857	1.060	1.272	1.372
67	105	KGN510611057	578	600	642	699	726	748	789	900	1.091	1.310	1.410
67	120	KGN510611207	611	635	680	748	772	794	853	982	1.213	1.456	1.556

Basi con maniglia
Base units with handle

Basi con gola
Base units with groove

Colonne
Tall units

Pensili
Wall units

Elementi speciali
Special elements

Maniglie gole zoccoli
Handles grooves plinth

Illuminazione
Lighting

Accessori
Accessories

Componenti e meccanismi
Components e mechanism

BASI CON GOLA PIANO COTTURA

H. 61,5

Hob base units with groove
Bases cuisson avec rainure
Bases con uñero para hornear
Kochfeld Unterschranke mit Griffleiste

Base cottura 1 anta

Hob base unit 1 hinged door
Base cuisson 1 porte
Base para hornear 1 puerta
Unterschrank für Kochfeldunterschrank 1 Tür

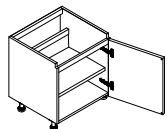

P/D	L/W	CODICE	0	1	2	3	4	5	6	7	8	9	10
57	45	KGC010610454	169	195	213	234	254	266	284	340	417	498	598
57	60	KGC010610604	178	211	231	257	282	300	324	377	465	555	655
67	45	KGC010610457	177	201	221	242	261	275	290	346	426	508	439
67	60	KGC010610607	187	219	237	265	288	308	331	384	473	565	665

Base cottura 2 ante

Hob base unit with 2 hinged doors
Base cuisson 2 portes
Base para hornear 2 puertas
Kochfeldunterschrank 2 Türen

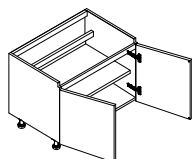

P/D	L/W	CODICE	0	1	2	3	4	5	6	7	8	9	10
57	90	KGC020610904	249	296	332	376	419	427	477	559	689	825	925
67	90	KGC020610907	261	307	343	386	429	437	487	570	702	839	939

Base cottura 1 estraibile + 1 cassetto interno

Hob base unit 1 pull-out + 1 inner drawer
Base cuisson 1 extractible + 1 tiroir intérieur
Base para hornear 1 extraíble + 1 cajón interior
Kochfeldunterschrank 1 Auszug + 1 Innenschubkasten

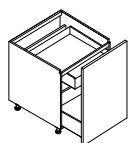

P/D	L/W	CODICE	0	1	2	3	4	5	6	7	8	9	10
57	45	KGC510610454	342	371	403	437	460	477	501	559	689	825	924
57	60	KGC510610604	360	403	427	471	501	515	553	632	778	932	1.032
57	75	KGC510610754	418	430	454	506	532	552	600	686	851	1.016	1.116
57	90	KGC510610904	471	492	533	580	613	633	683	772	954	1.142	1.242
57	105	KGC510611054	497	514	556	613	640	663	707	815	989	1.186	1.286
57	120	KGC510611204	546	566	612	680	701	724	784	913	1.124	1.345	1.445
67	45	KGC510610457	429	455	489	526	547	566	586	647	799	957	1.057
67	60	KGC510610607	449	489	514	559	584	605	642	718	889	1.064	1.164
67	75	KGC510610757	510	522	546	599	621	644	692	779	962	1.153	1.253
67	90	KGC510610907	565	591	631	681	712	733	781	868	1.072	1.284	1.384
67	105	KGC510611057	590	612	654	711	737	760	800	912	1.103	1.322	1.422
67	120	KGC510611207	623	647	692	760	784	806	864	993	1.225	1.468	1.568

BASI CON GOLA LAVELLO

H. 61,5

Sink base units with groove
Bases sous évier avec rainure
Bases fregadero con uñero
Spülenunterschranke mit Griffleiste

Base livello 1 anta

Sink base unit 1 door
Base sous évier 1 porte
Base fregadero 1 puerta
Spülenunterschrank 1 Tür

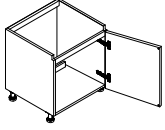

P/D	L/W	CODICE	0	1	2	3	4	5	6	7	8	9	10
57	45	KGL010610454	157	183	202	222	243	254	273	328	405	486	586
57	60	KGL010610604	167	200	219	245	271	288	312	366	453	543	643
67	45	KGL010610457	165	189	210	230	249	263	278	335	414	496	427
67	60	KGL010610607	176	208	225	253	276	297	319	372	461	553	653

Base livello 2 ante

Sink base unit 2 door
Base sous évier 2 portes
Base fregadero de 2 puertas
2-türiger Spülenunterschrank

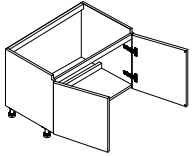

P/D	L/W	CODICE	0	1	2	3	4	5	6	7	8	9	10
57	90	KGL020610904	238	284	320	365	407	415	466	547	677	813	913
67	90	KGL020610907	249	295	332	374	417	426	475	559	690	827	927

Base livello 1 estraibile

Sink base unit 1 pull-out
Base sous évier 1 extractible
Base fregadero 1 extraíble
Spülenunterschrank 1 Auszug

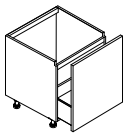

P/D	L/W	CODICE	0	1	2	3	4	5	6	7	8	9	10
57	45	KGL500610454	224	250	236	269	294	308	350	402	505	606	706
57	60	KGL500610604	232	239	243	276	302	315	358	408	513	614	714
57	75	KGL500610754	279	288	299	338	365	382	432	491	610	730	830
57	90	KGL500610904	331	337	362	400	431	449	505	569	707	848	948
57	105	KGL500611054	380	392	408	461	495	518	579	652	804	964	1.064
57	120	KGL500611204	432	446	465	524	560	586	655	732	903	1.082	1.182
67	45	KGL500610457	231	323	330	357	380	392	435	485	603	723	823
67	60	KGL500610607	313	331	338	365	388	404	442	493	611	731	831
67	75	KGL500610757	348	362	373	407	434	449	501	559	691	828	928
67	90	KGL500610907	382	393	414	452	482	501	560	624	772	925	1.025
67	105	KGL500611057	417	435	446	499	534	554	618	689	852	1.022	1.122
67	120	KGL500611207	452	469	489	542	583	605	674	756	933	1.119	1.219

Basi con maniglia
Base units with handle

Basi con gola
Base units with groove

Colonne
Tall units

Pensili
Wall units

Elementi speciali
Special elements

Maniglie gole zoccoli
Handles grooves plinth

Illuminazione
Lighting

Accessori
Accessories

Componenti e meccanismi
Components e mechanism

BASI CON GOLA

Base units with groove
Bases avec rainure
Bases con uñero
Unterschranke mit Griffleiste

H. 81

Riempitivo per base

Base unit filler
Fileur pour base
Regleta para base
Unterschrank-Füllstoff

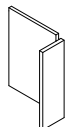

P/D	L/W	CODICE	0	1	2	3	4	5	6	7	8	9	10
34	4-15	KGN900810151	79	88	95	125	132	402	151	204	262	314	364

Base 1 anta

Base unit with 1 hinged door
Base 1 porte
Base 1 puerta
Unterschrank 1 Tür

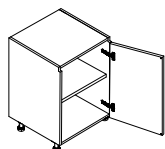

P/D	L/W	CODICE	0	1	2	3	4	5	6	7	8	9	10
34	15	KGN010810151	118	150	155	168	181	184	190	216	269	321	371
34	30	KGN010810301	133	161	174	202	217	218	235	269	331	396	446
34	45	KGN010810451	143	186	204	243	267	272	290	329	405	487	537
34	60	KGN010810601	157	196	220	270	297	304	337	391	486	583	633
34	75	KGN010810751	198	247	273	340	380	386	426	503	624	748	798
57	15	KGN010810154	118	150	155	168	181	184	190	216	269	321	371
57	30	KGN010810304	133	161	174	202	217	218	235	269	331	396	446
57	45	KGN010810454	143	186	204	243	267	272	290	329	405	487	537
57	60	KGN010810604	157	196	220	270	297	304	337	391	486	583	633
57	75	KGN010810754	198	247	273	340	380	386	426	503	624	748	798
67	15	KGN010810157	125	153	156	178	186	194	204	242	299	359	409
67	30	KGN010810307	143	174	181	210	224	226	243	276	342	410	460
67	45	KGN010810457	152	196	212	250	275	279	301	338	420	504	554
67	60	KGN010810607	166	205	230	277	306	313	347	402	496	595	645
67	75	KGN010810757	212	259	284	353	395	401	440	517	640	766	806

BASI CON GOLA

Base units with groove
Bases avec rainure
Bases con uñero
Unterschranke mit Griffleiste

H. 81

Base 1 anta + 2 cestoni interni

Base unit with 1 hinged door + 2 inner baskets
Base 1 porte + 2 paniers intérieurs
Base 1 puerta + 2 cestas interiores
Unterschrank 1 Tür + 2 Schubkasten

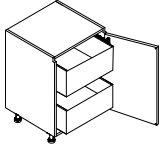

P/D	L/W	CODICE	0	1	2	3	4	5	6	7	8	9	10
57	45	KGK100810454	372	416	432	469	490	532	547	592	731	878	928
57	60	KGK100810604	391	435	453	503	526	571	605	663	819	983	1.033
57	75	KGK100810754	409	453	477	536	563	611	640	736	911	1.092	1.142
67	45	KGK100810457	481	528	540	580	594	649	662	702	869	1.042	1.092
67	60	KGK100810607	501	544	564	613	630	690	718	773	956	1.148	1.198
67	75	KGK100810757	526	567	592	651	672	734	755	851	1.053	1.263	1.313

Base 1 anta + 2 cassetti + 1 cestone interno

Base unit with 1 hinged door + 2 drawers + 1 inner basket
Base 1 porte + 2 tiroirs + 1 panier intérieur
Base 1 puerta + 2 cajones + 1 cajón interior
Unterschrank 1 Tür + 2 Schubladen + 1 Innenschubkast

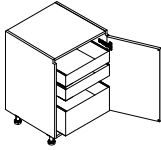

P/D	L/W	CODICE	0	1	2	3	4	5	6	7	8	9	10
57	45	KGK110810454	415	461	476	514	532	579	611	636	788	946	996
57	60	KGK110810604	437	480	500	549	567	613	651	708	877	1.052	1.102
57	75	KGK110810754	453	496	523	581	605	660	686	783	967	1.160	1.210
67	45	KGK110810457	546	592	605	645	655	718	750	766	949	1.139	1.189
67	60	KGK110810607	566	610	628	679	690	754	785	837	1.038	1.246	1.296
67	75	KGK110810757	589	629	656	715	733	803	819	917	1.133	1.360	1.410

Base 2 ante

Base unit with 2 hinged doors
Base 2 portes
Base de 2 puertas
2-türiger Unterschrank

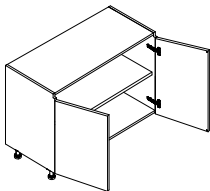

P/D	L/W	CODICE	0	1	2	3	4	5	6	7	8	9	10	
34	60	KGNO20810601	184	235	250	309	341	345	379	443	551	660	710	
34	90	KGNO20810901	210	258	295	372	417	434	476	563	695	833	883	
■	34	120	KGNO20811201	242	292	347	446	494	554	592	699	862	1.036	1.086
57	60	KGNO20810604	184	235	250	309	341	345	379	443	551	660	710	
57	90	KGNO20810904	210	258	295	372	417	434	476	563	695	833	883	
■	57	120	KGNO20811204	242	292	347	446	494	554	592	699	862	1.036	1.086
67	60	KGNO20810607	193	245	259	319	350	355	388	452	560	673	723	
67	90	KGNO20810907	222	274	309	384	433	447	490	574	712	854	904	
■	67	120	KGNO20811207	258	305	365	459	509	564	603	712	880	1.056	1.106

■ ripiano fornito con profilo di copertura | shelf supplied with cover profile | étagère fournie avec un profilé de couverture | estante con perfil de cubierta |
Fachboden mit Abdeckprofil geliefert

Basi con maniglia
Base units with handle

Basi con gola
Base units with groove

Colonne
Tall units

Pensili
Wall units

Elementi speciali
Special elements

Maniglie gole zoccoli
Handles grooves plinth

Illuminazione
Lighting

Accessori
Accessories

Componenti e meccanismi
Components e mechanism

BASI CON GOLLA

Base units with groove
Bases avec rainure
Bases con uñero
Unterschranke mit Griffleiste

H. 81

Base 1 estraibile con meccanismo Linea Pro Sige

Base unit 1 pull-out deep drawer with mechanism Linea Pro Sige
Base 1 extractible avec mécanisme Linea Pro Sige
Base 1 extraíble con mecanismo Linea Pro Sige
Unterschrank 1 Auszug mit Mechanismus Linea Pro Sige

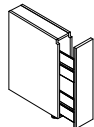

P/D	L/W	CODICE	0	1	2	3	4	5	6	7	8	9	10
57	15	KGN700810154	171	211	215	234	239	253	262	274	339	405	445

Maggiorazione per meccanismo Arena Style Kessebohmer PUNTI 95

Arena Style Kessebohmer mechanism | Supplément pour le mécanisme Arena Style Kessebohmer | Recargo para mecanismo Arena Style Kessebohmer | Aufpreis für Arena Style Kessebohmer Mechanismus

Base 1 estraibile con meccanismo Linea Pro Sige

Base unit 1 pull-out deep drawer with mechanism Linea Pro Sige
Base 1 extractible avec mécanisme Linea Pro Sige
Base 1 extraíble con mecanismo Linea Pro Sige
Unterschrank 1 Auszug mit Mechanismus Linea Pro Sige

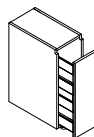

P/D	L/W	CODICE	0	1	2	3	4	5	6	7	8	9	10
57	30	KGN700810304	425	467	477	503	527	567	579	628	716	832	882

Maggiorazione per meccanismo Linea Pure Kessebohmer PUNTI 119

Mechanism Pure Kessebohmer Line | Supplément pour le mécanisme Linea Pure Kessebohmer | Recargo para mecanismo Linea Pure Kessebohmer | Aufpreis für Mechanismus Pure Kessebohmer Line

Base 4 cassetti

Base unit 4-drawer
Base 4 tiroirs
Base de 4 cajones
4-Schubladen-Unterschrank

Con fondo rientrato per apertura cassetto inferiore

With recessed bottom for bottom drawer opening
Avec fond en retrait pour l'ouverture du tiroir inférieur
Con fondo entrante para apertura cajón inferior
Mit vertieftem Boden für untere Schubladenöffnung

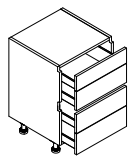

P/D	L/W	CODICE	0	1	2	3	4	5	6	7	8	9	10
57	45	KGN620810454	476	546	569	635	674	718	774	837	1.037	1.245	1.345
57	60	KGN620810604	491	568	585	664	698	751	793	876	1.082	1.298	1.398
57	75	KGN620810754	511	586	614	700	740	805	866	959	1.185	1.422	1.522
57	90	KGN620810904	535	601	646	736	774	835	905	1.012	1.251	1.501	1.601
57	105	KGN620811054	560	621	677	784	817	888	964	1.075	1.332	1.598	1.698
57	120	KGN620811204	580	637	706	808	857	933	1.022	1.142	1.412	1.695	1.795
67	45	KGN620810457	642	714	728	800	839	896	947	1.016	1.255	1.508	1.608
67	60	KGN620810607	656	734	749	830	861	930	959	1.052	1.301	1.562	1.662
67	75	KGN620810757	683	756	785	870	919	1.007	1.042	1.141	1.410	1.694	1.794
67	90	KGN620810907	705	772	815	906	937	1.020	1.077	1.187	1.468	1.762	1.862
67	105	KGN620811057	729	889	846	954	986	1.092	1.136	1.246	1.542	1.849	1.949
67	120	KGN620811207	751	807	876	980	1.025	1.107	1.192	1.312	1.623	1.947	2.047

BASI CON GOLA

Base units with groove
Bases avec rainure
Bases con uñero
Unterschranke mit Griffleiste

H. 81

Base 2 cassetti + 1 cestone

Base unit 2-drawers + 1 deep drawer
Base 2 tiroirs + 1 panier
Base 2 cajones + 1 cajón
Unterschrank 2 Schubladen + 1 Schubkast

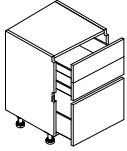

P/D	L/W	CODICE	0	1	2	3	4	5	6	7	8	9	10
57	45	KGN610810454	421	480	491	554	572	623	649	690	850	1.020	1.070
57	60	KGN610810604	439	505	521	592	610	662	690	749	921	1.106	1.156
57	75	KGN610810754	456	528	553	630	656	714	742	823	1.011	1.214	1.264
57	90	KGN610810904	472	546	585	665	696	749	797	893	1.100	1.320	1.370
57	105	KGN610811054	506	568	617	711	734	803	853	978	1.203	1.442	1.492
57	120	KGN610811204	560	603	663	760	792	781	925	1.056	1.300	1.559	1.609
67	45	KGN610810457	553	610	621	684	699	763	779	821	1.010	1.213	1.263
67	60	KGN610810607	568	636	652	721	733	800	821	880	1.083	1.299	1.349
67	75	KGN610810757	592	661	687	764	790	853	880	954	1.179	1.414	1.464
67	90	KGN610810907	606	680	717	799	828	884	931	1.028	1.266	1.519	1.569
67	105	KGN610811057	640	703	748	849	868	938	986	1.110	1.370	1.643	1.693
67	120	KGN610811207	677	724	880	879	911	995	1.045	1.177	1.450	1.740	1.790

Base 1 cassetto + 1 estraibile + cassetto interno

Base unit 1 drawer + 1 pull-out deep drawer + inner drawer
Base 1 tiroir + 1 extractible + tiroir intérieur
Base 1 cajón + 1 extraible + cajón interior
Unterschrank 1 Schublade + 1 Auszug + Innenschublade

Apertura solo con gola intermedia

Opening only with middle groove
Ouverture uniquement avec rainure intermédiaire
Apertura sólo con ranura intermedia
Schubladenöffnung nur mit Zwischennut

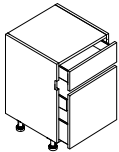

P/D	L/W	CODICE	0	1	2	3	4	5	6	7	8	9	10
57	45	KGN590810454	418	477	489	551	570	621	646	688	848	1.018	1.118
57	60	KGN590810604	442	508	524	595	613	664	694	751	924	1.109	1.209
57	75	KGN590810754	464	536	561	638	664	722	751	831	1.020	1.223	1.323
57	90	KGN590810904	486	561	598	682	711	762	811	908	1.115	1.335	1.435
57	105	KGN590811054	561	647	691	790	823	882	939	1.052	1.294	1.550	1.650
57	120	KGN590811204	639	737	789	901	937	1.005	1.073	1.203	1.477	1.769	1.869
67	45	KGN590810457	594	652	663	726	741	805	819	862	1.053	1.256	1.356
67	60	KGN590810607	621	689	703	773	786	853	874	933	1.138	1.353	1.453
67	75	KGN590810757	655	724	750	827	853	917	944	1.019	1.245	1.489	1.589
67	90	KGN590810907	681	755	792	874	903	957	1.006	1.102	1.343	1.595	1.695
67	105	KGN590811057	783	870	911	1.008	1.042	1.106	1.162	1.274	1.555	1.850	1.950
67	120	KGN590811207	885	985	1.029	1.143	1.180	1.253	154	1.446	1.766	2.103	2.203

Base 1 cassetto + 1 anta

Base unit 1 drawer + 1 hinged door
Base 1 tiroir + 1 porte
Base 1 cajón + 1 puerta
Unterschrank 1 Schublade + 1 Tür

Apertura solo con gola intermedia

Opening only with middle groove
Ouverture uniquement avec rainure intermédiaire
Apertura sólo con ranura intermedia
Schubladenöffnung nur mit Zwischennut

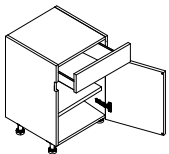

P/D	L/W	CODICE	0	1	2	3	4	5	6	7	8	9	10
57	45	KGN570810454	280	331	372	431	460	499	521	575	721	884	934
57	60	KGN570810604	296	353	384	440	471	505	527	585	731	897	937
67	45	KGN570810457	362	410	450	508	538	583	604	656	806	984	1.034
67	60	KGN570810607	375	434	466	523	552	592	611	665	816	997	1.047

Basi con maniglia
Base units with handle

Basi con gola
Base units with groove

Colonne
Tall units

Pensili
Wall units

Elementi speciali
Special elements

Maniglie gole zoccoli
Handles grooves plinth

Illuminazione
Lighting

Accessori
Accessories

Componenti e meccanismi
Components e mechanism

BASI CON GOLA

Base units with groove
Bases avec rainure
Bases con uñero
Unterschranke mit Griffleiste

H. 81

Base 1 cassetto + 2 ante

Base unit 1 drawer + 2 hinged doors
Base 1 tiroir + 2 portes
Base 1 cajón + 2 puertas
Unterschrank 1 Schublade + 2 Türen

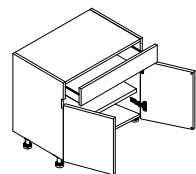

Apertura solo con gola intermedia
Opening only with middle groove
Ouverture uniquement avec rainure intermédiaire
Apertura sólo con ranura intermedia
Schubladenöffnung nur mit Zwischennut

P/D	L/W	CODICE	0	1	2	3	4	5	6	7	8	9	10
57	90	KG580810904	392	469	482	557	589	643	678	772	972	1.187	1.237
67	90	KG580810907	464	514	528	585	619	683	709	757	950	1.161	1.211

Base 2 cestoni

Base unit 2 deep drawers
Base 2 paniers
Base 2 cestas
Unterschrank 2 Schubkasten

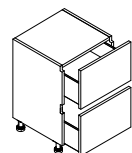

P/D	L/W	CODICE	0	1	2	3	4	5	6	7	8	9	10
57	45	KG540810454	372	421	464	521	550	589	611	665	815	977	1.027
57	60	KG540810604	386	443	475	532	562	596	618	674	825	991	1.041
57	75	KG540810754	404	481	485	553	585	649	672	738	904	1.085	1.135
57	90	KG540810904	417	496	506	580	617	699	728	798	980	1.176	1.136
57	105	KG540811054	485	554	594	669	696	792	820	910	1.117	1.341	1.394
57	120	KG540811204	583	637	691	780	818	889	960	1.050	1.282	1.539	1.589
67	45	KG540810457	451	501	541	599	630	673	695	747	898	1.078	1.138
67	60	KG540810607	467	525	557	612	642	682	702	757	910	1.090	1.140
67	75	KG540810757	482	561	566	631	664	733	757	819	986	1.184	1.234
67	90	KG540810907	499	576	587	661	696	784	809	882	1.064	1.277	1.327
67	105	KG540811057	567	631	673	749	775	878	901	989	1.198	1.440	1.490
67	120	KG540811207	653	706	762	851	888	960	1.028	1.117	1.373	1.647	1.697

Base 2 cestoni + 1 cassetto interno

Base unit 2 baskets + 1 internal drawer
Base 2 paniers + 1 tiroir intérieur
Base 2 cestas + 1 cajón interior
Unterschrank 2 Schubkasten + 1 Innenschublade

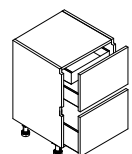

P/D	L/W	CODICE	0	1	2	3	4	5	6	7	8	9	10
57	45	KG560810454	437	489	502	559	593	656	671	721	886	1.063	1.113
57	60	KG560810604	456	514	533	592	617	670	711	791	974	1.168	1.218
57	75	KG560810754	474	541	563	624	647	706	757	844	1.039	1.247	1.297
57	90	KG560810904	494	570	585	658	691	745	781	874	1.077	1.292	1.342
57	105	KG560811054	555	632	669	749	779	850	900	1.006	1.198	1.440	1.490
57	120	KG560811204	698	754	803	893	929	1.002	1.072	1.161	1.423	1.707	1.757
67	45	KG560810457	566	617	630	687	721	785	812	858	1.055	1.266	1.316
67	60	KG560810607	589	647	663	724	742	814	852	933	1.148	1.377	1.427
67	75	KG560810757	610	678	698	760	781	857	896	986	1.215	1.458	1.508
67	90	KG560810907	629	707	718	794	827	884	919	1.012	1.247	1.495	1.545
67	105	KG560811057	690	769	801	886	914	990	1.036	1.145	1.370	1.643	1.693
67	120	KG560811207	779	831	886	978	1.014	1.084	1.153	1.244	1.532	1.840	1.890

BASI CON GOLA

Base units with groove
Bases avec rainure
Bases con uñero
Unterschranke mit Griffleiste

H. 81

Base 1 estraibile + 1 cestone interno

Base unit 1 pull-out deep drawer + 1 inner basket
Base 1 extractible + 1 panier intérieur
Base 1 extraible + 1 cajón interior
Unterschrank 1 Auszug + 1 Innenschubladen

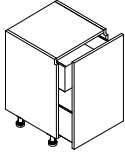

P/D	L/W	CODICE	0	1	2	3	4	5	6	7	8	9	10
57	45	KG530810454	372	416	432	469	490	532	547	592	731	878	928
57	60	KG530810604	391	435	453	503	526	571	605	663	819	983	1.033
57	75	KG530810754	409	453	477	536	563	611	640	736	911	1.092	1.142
67	45	KG530810457	481	528	540	580	594	649	662	702	869	1.042	1.092
67	60	KG530810607	501	544	564	613	630	690	718	773	956	1.148	1.198
67	75	KG530810757	526	567	592	651	672	734	755	851	1.053	1.263	1.313

Base 1 estraibile + 2 cassetti interni

Base unit 1 pull-out deep drawer + 2 internal drawers
Base 1 extractible + 2 tiroirs intérieurs
base 1 extraible + 2 cajones interiores
Unterschrank 1 Auszug + 2 Innenschubladen

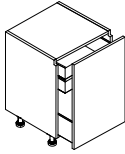

P/D	L/W	CODICE	0	1	2	3	4	5	6	7	8	9	10
57	45	KG520810454	415	461	476	514	532	579	611	636	788	946	996
57	60	KG520810604	437	480	500	549	567	613	651	708	877	1.052	1.102
57	75	KG520810754	453	496	523	581	605	660	686	783	967	1.160	1.210
67	45	KG520810457	546	592	605	645	655	718	750	766	949	1.139	1.189
67	60	KG520810607	566	610	628	679	690	754	785	837	1.038	1.246	1.296
67	75	KG520810757	589	629	656	715	733	803	819	917	1.133	1.360	1.410

Base 1 estraibile con pattumiera (1 x 35l)

Base unit 1 removable with dustbin (1 x 35l)
Base 1 extractible avec poubelle (1 x 35l)
Base 1 extraible con cubo de basura (1 x 35l)
Unterschrank 1 Auszug mit Mülleimer (1 x 35l)

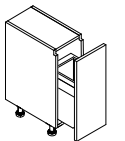

P/D	L/W	CODICE	0	1	2	3	4	5	6	7	8	9	10
57	30	KG790810304	358	399	412	450	465	520	554	595	766	749	999
67	30	KG790810307	377	418	432	469	484	539	573	614	786	969	1.019

Basi con maniglia
Base units with handle

Basi con gola
Base units with groove

Colonne
Tall units

Pensili
Wall units

Elementi speciali
Special elements

Maniglie gole zoccoli
Handles grooves plinth

Illuminazione
Lighting

Accessori
Accessories

Componenti e meccanismi
Components e mechanism

BASI CON GOLA

Base units with groove
Bases avec rainure
Bases con uñero
Unterschranke mit Griffleiste

H. 81

Base 1 estraibile con pattumiera (2 x 35l) + 1 cassetto interno

Base unit 1 pull-out with dustbin (2 x 35l) + 1 internal drawer
Base 1 extractible avec poubelle (2 x 35l) + 1 tiroir intérieur
Base 1 extraíble con cubo de basura (2 x 35l) + 1 cajón interior
Unterschrank 1 Auszug mit Mülleimer (2 x 35l) + 1 Innenschublade

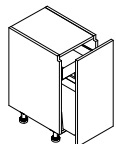

P/D	L/W	CODICE	0	1	2	3	4	5	6	7	8	9	10
57	45	KGN790810454	503	544	558	596	610	665	699	740	916	1.099	1.149
67	45	KGN790810457	523	564	577	615	630	685	719	760	936	1.119	1.169

Base 1 estraibile con pattumiera (2 x 35l + 2 x 8l) + 1 cassetto interno

Base unit 1 pull-out with dustbin (2 x 35l + 2 x 8l) + 1 internal drawer
Base 1 extractible avec poubelle (2 x 35l + 2 x 8l) + 1 tiroir intérieur
Base 1 extraíble con cubo de basura (2 x 35l + 2 x 8l) + 1 cajón interior
Unterschrank 1 Auszug mit Mülleimer (2 x 35l + 2 x 8l) + 1 Innenschublade

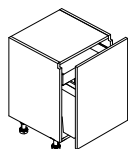

P/D	L/W	CODICE	0	1	2	3	4	5	6	7	8	9	10
57	60	KGN790810604	664	702	720	769	805	879	905	963	1.192	1.431	1.481
67	60	KGN790810607	684	722	739	789	825	801	924	983	1.212	1.451	1.501

BASI CON GOLA PIANO COTTURA E FORNO

H. 81

Hob base units with groove for oven
Bases cuisson et four avec rainure
Bases para hornear con horno con uñero
Kochfeld/Backofen Unterschränke mit Griffleiste

Base cottura 1 anta

Hob base unit 1 hinged door
Base cuisson 1 porte
Base para hornear 1 puerta
Unterschrank für Kochfeldunterschrank 1 Tür

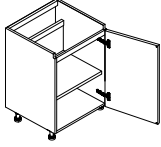

P/D	L/W	CODICE	0	1	2	3	4	5	6	7	8	9	10
57	45	KGC010810454	154	198	215	254	278	283	302	340	417	499	549
57	60	KGC010810604	169	208	232	281	308	315	348	403	498	595	645
57	75	KGC010810754	210	259	284	351	392	398	437	515	636	760	810
67	45	KGC010810457	164	208	224	262	287	291	312	349	432	516	566
67	60	KGC010810607	178	216	242	289	317	325	359	413	508	607	657
67	75	KGC010810757	224	271	296	365	406	412	452	529	652	778	818

Base cottura 2 ante

Hob base unit with 2 hinged doors
Base cuisson 2 portes
Base para hornear 2 puertas
Kochfeldunterschrank 2 Türen

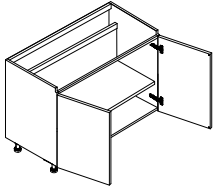

P/D	L/W	CODICE	0	1	2	3	4	5	6	7	8	9	10
57	60	KGC020810604	196	246	262	321	353	357	391	455	563	672	722
57	90	KGC020810904	222	270	307	383	429	445	488	574	707	845	895
57	120	KGC020811204	253	304	359	458	214	566	603	711	874	1.048	1.098
67	60	KGC020810607	205	257	271	331	362	367	400	464	572	685	735
67	90	KGC020810907	234	285	321	396	444	459	501	586	724	866	916
67	120	KGC020811207	270	316	376	470	521	575	615	724	892	1.068	1.118

- ripianto fornito con profilo di copertura | shelf supplied with cover profile | étagère fournie avec un profilé de couverture | estante con perfil de cubierta |
Fachboden mit Abdeckprofil geliefert

Base cottura 4 cassetti

Hob base unit 4-drawer
Base cuisson à 4 tiroirs
Base para hornear de 4 cajones
Kochfeldunterschrank mit 4 Schubladen

Con fondo rientrato per apertura cassetto inferiore
With recessed bottom for bottom drawer opening
Avec fond en retrait pour l'ouverture du tiroir inférieur
Con fondo entrante para apertura cajón inferior
Mit vertieftem Boden für untere Schubladenöffnung

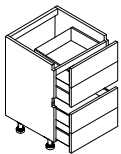

P/D	L/W	CODICE	0	1	2	3	4	5	6	7	8	9	10
57	45	KGC620810454	488	558	581	647	686	729	786	849	1.049	1.257	1.357
57	60	KGC620810604	502	580	597	676	710	762	805	888	1.094	1.310	1.410
57	75	KGC620810754	523	598	626	712	752	817	878	971	1.197	1.434	1.534
57	90	KGC620810904	547	613	658	748	786	847	917	1.023	1.263	1.513	1.613
57	105	KGC620811054	571	632	689	795	828	899	976	1.086	1.344	1.610	1.710
57	120	KGC620811204	592	649	718	820	868	945	1.034	1.153	1.424	1.707	1.807
67	45	KGC620810457	654	726	740	812	851	908	958	1.027	1.267	1.520	1.620
67	60	KGC620810607	667	746	760	842	873	942	971	1.064	1.313	1.574	1.674
67	75	KGC620810757	695	767	796	882	930	1.019	1.053	1.152	1.422	1.706	1.806
67	90	KGC620810907	717	784	826	918	949	1.032	1.088	1.199	1.480	1.774	1.874
67	105	KGC620811057	741	800	857	965	998	1.104	1.148	1.258	1.554	1.861	1.961
67	120	KGC620811207	762	819	888	991	1.037	1.118	1.204	1.324	1.635	1.959	2.059

Basi con maniglia
Base units with handle

Basi con gola
Base units with groove

Colonne
Tall units

Pensili
Wall units

Elementi speciali
Special elements

Maniglie gole zoccoli
Handles grooves plinth

Illuminazione
Lighting

Accessori
Accessories

Componenti e meccanismi
Components e mechanism

BASI CON GOLA PIANO COTTURA E FORNO

H. 81

Hob base units with groove for oven
Bases cuisson et four avec rainure
Bases para hornear con horno con uñero
Kochfeld/Backofen Unterschränke mit Griffleiste

Base cottura 2 cassetti + 1 cestone

Hob base unit 2 drawers + 1 deep drawer
Base cuisson 2 tiroirs + 1 panier
Base para hornear 2 cajones + 1 cajón
Kochfeldunterschrank 2 Schubladen + 1 Schubkast

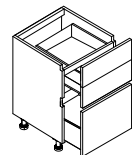

P/D	L/W	CODICE	0	1	2	3	4	5	6	7	8	9	10
57	45	KGC610810454	433	492	502	566	584	634	661	701	862	1.032	1.082
57	60	KGC610810604	451	517	533	603	622	673	701	760	933	1.118	1.168
57	75	KGC610810754	468	539	565	641	667	726	754	834	1.023	1.226	1.276
57	90	KGC610810904	484	558	597	677	708	760	809	905	1.112	1.332	1.382
57	105	KGC610811054	518	580	629	723	746	815	864	989	1.215	1.454	1.504
57	120	KGC610811204	571	615	674	771	803	792	937	1.068	1.312	1.571	1.621
67	45	KGC610810457	565	622	632	695	711	775	791	832	1.022	1.225	1.275
67	60	KGC610810607	580	648	663	732	745	812	832	891	1.095	1.311	1.361
67	75	KGC610810757	603	672	698	776	801	864	891	966	1.191	1.426	1.476
67	90	KGC610810907	618	692	728	811	840	895	943	1.040	1.278	1.531	1.581
67	105	KGC610811057	652	715	760	860	880	950	997	1.121	1.382	1.655	1.705
67	120	KGC610811207	689	735	891	890	922	1.007	1.056	1.188	1.462	1.752	1.802

Base cottura 1 cassetto + 1 estraibile + 1 cassetto interno

Hob base unit 1 drawer + 1 pull-out + 1 inner drawer
Base cuisson 1 tiroir + 1 extractible + 1 tiroir intérieur
Base para hornear 1 cajón + 1 extraíble + 1 cajón interior
Kochfeldunterschrank 1 Schublade + 1 Auszug + 1 Innenschublade

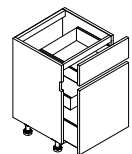

P/D	L/W	CODICE	0	1	2	3	4	5	6	7	8	9	10
57	45	KGC590810454	430	489	501	563	582	632	658	699	860	1.030	1.130
57	60	KGC590810604	454	520	535	606	625	676	705	762	936	1.121	1.221
57	75	KGC590810754	475	548	572	650	676	733	762	843	1.032	1.235	1.335
57	90	KGC590810904	498	572	609	694	723	774	823	920	1.127	1.347	1.447
57	105	KGC590811054	572	659	702	801	834	893	951	1.064	1.306	1.562	1.662
57	120	KGC590811204	651	749	800	913	949	1.017	1.084	1.214	1.489	1.781	1.881
67	45	KGC590810457	605	663	674	737	753	817	830	874	1.065	1.268	1.368
67	60	KGC590810607	632	700	715	785	797	864	886	945	1.150	1.365	1.465
67	75	KGC590810757	666	735	761	839	864	928	955	1.030	1.257	1.501	1.601
67	90	KGC590810907	693	766	803	886	915	969	1.018	1.114	1.355	1.607	1.707
67	105	KGC590811057	794	882	922	1.019	1.053	1.117	1.174	1.285	1.567	1.862	1.962
67	120	KGC590811207	896	996	1.041	1.154	1.191	1.265	1.366	1.458	1.778	2.115	2.215

Apertura solo con gola intermedia

Opening only with middle groove

Ouverture uniquement avec rainure intermédiaire

Apertura sólo con ranura intermedia

Schubladenöffnung nur mit Zwischennut

Base cottura 1 cassetto + 1 anta

Hob base unit 1 drawer + 1 hinged door
Base cuisson 1 tiroir + 1 porte
Base para hornear 1 cajón + 1 puerta
Kochfeldunterschrank 1 Schublade + 1 Tür

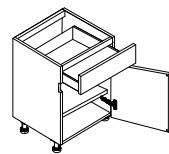

P/D	L/W	CODICE	0	1	2	3	4	5	6	7	8	9	10
57	45	KGC570810454	292	342	384	442	471	510	533	587	733	896	946
57	60	KGC570810604	307	365	396	452	483	517	538	597	743	909	949
67	45	KGC570810457	373	422	462	520	550	595	616	667	818	996	1.046
67	60	KGC570810607	387	445	477	534	564	603	623	677	828	1.009	1.059

Apertura solo con gola intermedia

Opening only with middle groove

Ouverture uniquement avec rainure intermédiaire

Apertura sólo con ranura intermedia

Schubladenöffnung nur mit Zwischennut

BASI CON GOLA PIANO COTTURA E FORNO

H. 81

Hob base units with groove for oven
Bases cuisson et four avec rainure
Bases para hornear con horno con uñero
Kochfeld/Backofen Unterschränke mit Griffleiste

Base cottura 1 cassetto + 2 ante

Hob base unit 1 drawer + 2 hinged doors
Base cuisson 1 tiroir + 2 portes
Base para hornear 1 cajón + 2 puertas
Kochfeldunterschrank 1 Schublade + 2 Türen

Apertura solo con gola intermedia

Opening only with middle groove

Ouverture uniquement avec rainure intermédiaire

Apertura sólo con ranura intermedia

Schubladenöffnung nur mit Zwischennut

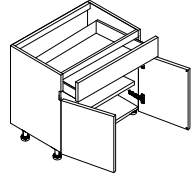

P/D	L/W	CODICE	0	1	2	3	4	5	6	7	8	9	10
57	90	KGC580810904	404	480	494	568	600	655	690	784	984	1.199	1.249
67	90	KGC580810907	475	526	539	597	631	695	721	768	962	1.173	1.223

Base cottura 2 cestoni

Hob base unit with 2 deep drawers
Base cuisson 2 paniers
Base para hornear 2 cestas
Kochfeldunterschrank 2 Schubkasten

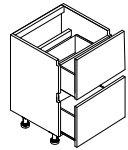

P/D	L/W	CODICE	0	1	2	3	4	5	6	7	8	9	10
57	45	KGC540810454	383	433	475	533	562	600	623	677	827	989	1.039
57	60	KGC540810604	398	455	487	543	573	607	630	686	837	1.003	1.053
57	75	KGC540810754	415	493	497	565	597	661	684	750	916	1.097	1.147
57	90	KGC540810904	429	507	518	592	629	711	740	810	992	1.188	1.148
57	105	KGC540811054	497	566	605	681	708	804	831	922	1.129	1.353	1.406
57	120	KGC540811204	595	649	702	792	829	900	972	1.061	1.294	1.551	1.601
67	45	KGC540810457	463	513	553	611	641	685	707	759	910	1.090	1.150
67	60	KGC540810607	478	536	568	624	654	694	714	768	922	1.102	1.152
67	75	KGC540810757	494	572	577	642	676	745	768	830	998	1.196	1.246
67	90	KGC540810907	510	588	598	672	708	795	821	893	1.076	1.289	1.339
67	105	KGC540811057	579	643	685	760	787	889	913	1.001	1.210	1.452	1.502
67	120	KGC540811207	664	718	774	862	899	972	1.040	1.129	1.385	1.659	1.709

Base cottura 2 cestoni + 1 cassetto interno

Hob base unit with 2 deep drawers + 1 internal drawer
Base cuisson 2 paniers + 1 tiroir intérieur
Base para hornear 2 cestas + 1 cajón interior
Kochfeldunterschrank 2 Schubkasten + 1 Innenschublade

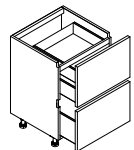

P/D	L/W	CODICE	0	1	2	3	4	5	6	7	8	9	10
57	45	KGC560810454	449	501	514	570	604	667	683	732	898	1.075	1.125
57	60	KGC560810604	468	526	544	603	629	682	723	802	986	1.180	1.230
57	75	KGC560810754	486	553	574	635	659	718	768	856	1.051	1.259	1.309
57	90	KGC560810904	505	582	597	669	702	757	792	886	1.089	1.304	1.354
57	105	KGC560811054	566	644	681	760	791	861	912	1.018	1.210	1.452	1.502
57	120	KGC560811204	710	765	815	905	941	1.014	1.083	1.173	1.435	1.719	1.769
67	45	KGC560810457	577	629	641	698	732	796	824	870	1.067	1.278	1.328
67	60	KGC560810607	600	659	674	735	754	825	863	945	1.160	1.389	1.439
67	75	KGC560810757	622	690	710	772	792	869	908	998	1.227	1.470	1.520
67	90	KGC560810907	640	719	729	806	839	895	930	1.023	1.259	1.507	1.557
67	105	KGC560811057	701	781	813	897	925	1.002	1.048	1.156	1.382	1.655	1.705
67	120	KGC560811207	791	843	897	989	1.025	1.096	1.165	1.255	1.544	1.852	1.902

Basi con maniglia
Base units with handle

Basi con gola
Base units with groove

Colonne
Tall units

Pensili
Wall units

Elementi speciali
Special elements

Maniglie gole zoccoli
Handles grooves plinth

Illuminazione
Lighting

Accessori
Accessories

Componenti e meccanismi
Components e mechanism

BASI CON GOLA PIANO COTTURA E FORNO

H. 81

Hob base units with groove for oven
Bases cuisson et four avec rainure
Bases para hornear con horno con uñero
Kochfeld/Backofen Unterschränke mit Griffleiste

Base cottura 1 estraibile + 1 cestone interno

Hob base unit 1 pull-out + 1 inner basket
Base cuisson 1 extractible + 1 panier intérieur
Base para hornear 1 extraíble + 1 cajón interior
Kochfeldunterschrank 1 Auszug + 1 Innenschubkasten

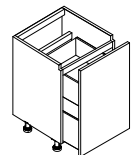

P/D	L/W	CODICE	0	1	2	3	4	5	6	7	8	9	10
57	45	KGC530810454	384	428	443	481	501	543	559	603	743	890	940
57	60	KGC530810604	403	446	465	515	537	583	617	674	831	995	1.045
57	75	KGC530810754	421	465	489	548	574	623	652	748	923	1.104	1.154
67	45	KGC530810457	493	539	552	592	605	661	673	714	881	1.054	1.104
67	60	KGC530810607	513	556	575	625	641	701	729	785	968	1.160	1.210
67	75	KGC530810757	537	579	603	663	684	746	766	862	1.065	1.275	1.325

Base cottura 1 estraibile + 2 cassetti interni

Hob base unit 1 pull-out + 2 internal drawers
Base cuisson 1 extractible + 2 tiroirs intérieurs
Base para hornear 1 extraíble + 2 cajones interiores
Kochfeldunterschrank 1 Auszug + 2 Innenschubladen

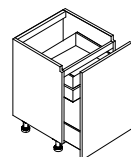

P/D	L/W	CODICE	0	1	2	3	4	5	6	7	8	9	10
57	45	KGC520810454	427	472	488	526	543	591	623	648	800	958	1.008
57	60	KGC520810604	449	492	511	561	579	625	663	720	889	1.064	1.114
57	75	KGC520810754	465	507	534	593	617	671	697	794	979	1.172	1.222
67	45	KGC520810457	558	603	617	657	666	729	761	778	961	1.151	1.201
67	60	KGC520810607	578	622	639	691	701	765	796	849	1.050	1.258	1.308
67	75	KGC520810757	600	640	667	727	745	815	830	928	1.145	1.372	1.422

Base cottura cappa integrata 2 cestoni

Integrated hood 2 baskets
Base cuisson hotte intégrée 2 paniers
Base para hornear con campana integrada 2 cestas
Kochfeldunterschrank mit Integrierte Dunstabzugshaube 2 Schubkasten

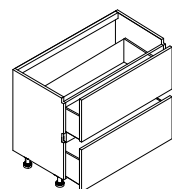

P/D	L/W	CODICE	0	1	2	3	4	5	6	7	8	9	10
57	90	KGC550810904	440	519	530	603	640	723	752	822	1.004	1.200	1.160
57	105	KGC550811054	508	577	617	693	720	816	843	933	1.141	1.365	1.418
57	120	KGC550811204	606	661	714	803	841	912	984	1.073	1.306	1.563	1.613
67	90	KGC550810907	522	599	610	684	720	807	832	905	1.088	1.301	1.351
67	105	KGC550811057	591	655	696	772	798	901	924	1.013	1.222	1.464	1.514
67	120	KGC550811207	676	729	786	874	911	984	1.051	1.141	1.397	1.671	1.721

BASI CON GOLA PIANO COTTURA E FORNO

H. 81

Hob base units with groove for oven
Bases cuisson et four avec rainure
Bases para hornear con horno con uñero
Kochfeld/Backofen Unterschränke mit Griffleiste

Base cottura cappa integrata 1 frontale fisso + 2 ante

Integrated hood 1 fixed front + 2 hinged doors
Base cuisson hotte intégrée 1 façade fixe + 2 portes
Base para hornear con campana integrada 1 frente fijo + 1 cajón + 2 puertas
Kochfeldunterschrank mit Integrierte Dunstabzugshaube 1 feste Front + 2 Türen

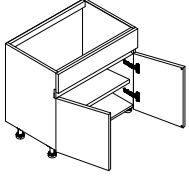

P/D	L/W	CODICE	0	1	2	3	4	5	6	7	8	9	10
57	90	KGC320810904	404	480	494	568	600	655	690	784	984	1.199	1.249
57	120	KGC320811204	442	519	533	607	639	694	728	823	1.024	1.239	1.289
67	90	KGC320810907	475	526	539	597	631	695	721	768	962	1.173	1.223
67	120	KGC320811207	514	565	578	635	669	733	760	807	1.002	1.213	1.263

Base cottura cappa integrata 1 frontale fisso + 1 cassetto + 1 cestone

Integrated hood base unit 1 fixed front + 1 drawer + 1 basket
Base cuisson hotte intégrée 1 façade fixe + 1 tiroir + 1 panier
Base para hornear con campana integrada 1 frente fijo + 1 cajón + 1 cesta
Integrierte Dunstabzugshaube Kochfeldunterschrank 1 feste Front + 1 Schublade + 1 Schubkast

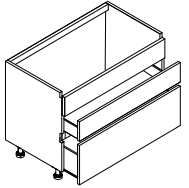

P/D	L/W	CODICE	0	1	2	3	4	5	6	7	8	9	10
57	90	KGC360810904	484	558	597	677	708	760	809	905	1.112	1.332	1.382
57	105	KGC360811054	518	580	629	723	746	815	864	989	1.215	1.454	1.504
57	120	KGC360811204	571	615	674	771	803	792	937	1.068	1.312	1.571	1.621
67	90	KGC360810907	618	692	728	811	840	895	943	1.040	1.278	1.531	1.581
67	105	KGC360811057	652	715	760	860	880	950	997	1.121	1.382	1.655	1.705
67	120	KGC360811207	689	735	891	890	922	1.007	1.056	1.188	1.462	1.752	1.802

Base cottura e forno 2 frontali fissi

Hob base unit and oven 2 fixed fronts
Base cuisson et four 2 façades fixes
Base para hornear con horno 2 frentes fijos
Unterschrank und Backofen 2 feste Fronten

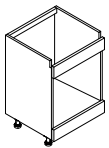

P/D	L/W	CODICE	0	1	2	3	4	5	6	7	8	9	10
57	60	KG0300810604	140	166	170	194	204	219	235	255	295	355	385
57	75	KG0300810754	152	178	181	212	218	230	249	271	306	367	442
67	60	KG0300810607	155	181	185	210	219	235	250	271	311	371	401
67	75	KG0300810757	168	194	197	228	234	245	255	286	322	383	458

Basi con maniglia
Base units with handle

Basi con gola
Base units with groove

Colonne
Tall units

Pensili
Wall units

Elementi speciali
Special elements

Maniglie gole zoccoli
Handles grooves plinth

Illuminazione
Lighting

Accessori
Accessories

Componenti e meccanismi
Components e mechanism

BASI CON GOLA PIANO COTTURA E FORNO

H. 81

Hob base units with groove for oven
Bases cuisson et four avec rainure
Bases para hornear con horno con uñero
Kochfeld/Backofen Unterschränke mit Griffleiste

Base cottura e forno H. 46 con 1 frontale fisso + 1 cassetto

Hob base unit for H 46 oven with 1 fixed front + 1 drawer
Base cuisson et four H 46 1 façade fixe + 1 tiroir
Base para hornear con horno H.46 con 1 frente fijo + 1 cajón
H 46 Kochfeld und Backofenunterschrank mit 1 festen Front + 1 Schublade

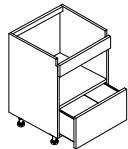

P/D	L/W	CODICE	0	1	2	3	4	5	6	7	8	9	10
57	60	KG0330810604	275	316	340	381	404	438	456	520	625	749	799
67	60	KG0330810607	331	363	393	430	453	500	518	574	678	814	864

Base cottura e forno H. 48 con 1 frontale fisso + 1 cassetto

Hob base unit for H 48 oven with 1 fixed front + 1 drawer
Base cuisson et four H 48 1 façade fixe + 1 tiroir
Base para hornear con horno H.48 con 1 frente fijo + 1 cajón
H 48 Kochfeld und Backofenunterschrank mit 1 festen Front + 1 Schublade

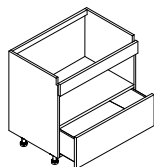

P/D	L/W	CODICE	0	1	2	3	4	5	6	7	8	9	10
57	90	KG0330810904	324	365	389	430	452	487	504	568	675	799	849
67	90	KG0330810907	379	411	441	478	501	548	566	623	728	864	914

Protezione sotto piano induzione

Protection under induction hob
Protection sous la table de cuisson à induction
Protección bajo placa de inducción
Schutz Induktionskochfeldern

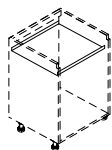

P/D	L/W	CODICE	0	1	2	3	4	5	6	7	8	9	10
50	60	KVP010564936	50	-	-	-	-	-	-	-	-	-	-
50	75	KVP010714936	63	-	-	-	-	-	-	-	-	-	-
50	90	KVP010864936	67	-	-	-	-	-	-	-	-	-	-
50	105	KVP011014936	74	-	-	-	-	-	-	-	-	-	-
50	120	KVP011164936	81	-	-	-	-	-	-	-	-	-	-

BASI CON GOLA LAVELLO

H. 81

Sink base units with groove
Bases sous évier avec rainure
Bases fregadero con uñero
Spülenunterschranke mit Griffleiste

Base livello 1 anta

Sink base unit 1 door
Base sous évier 1 porte
Base fregadero 1 puerta
Spülenunterschrank 1 Tür

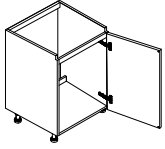

P/D	L/W	CODICE	0	1	2	3	4	5	6	7	8	9	10
57	45	KGL010810454	153	190	208	246	270	279	296	331	408	489	510
57	60	KGL010810604	165	200	222	272	302	318	340	388	482	578	613
57	75	KGL010810754	183	219	251	312	349	372	405	469	585	700	725
67	45	KGL010810457	161	200	215	254	278	283	304	339	420	505	519
67	60	KGL010810607	177	210	233	279	309	312	350	400	493	592	623
67	75	KGL010810757	202	234	262	320	356	361	418	484	596	715	736

Base livello 2 ante

Sink base unit 2 door
Base sous évier 2 portes
Base fregadero de 2 puertas
2-türiger Spülenunterschrank

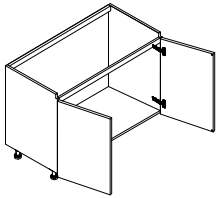

P/D	L/W	CODICE	0	1	2	3	4	5	6	7	8	9	10
57	60	KGL020810604	186	236	252	312	344	365	381	443	549	658	744
57	90	KGL020810904	221	271	304	379	427	447	482	557	687	824	957
57	120	KGL020811204	259	310	355	450	507	530	595	692	857	1.027	1.167
67	60	KGL020810607	196	247	262	321	353	372	390	451	559	672	754
67	90	KGL020810907	235	283	318	393	441	459	499	569	705	845	968
67	120	KGL020811207	274	323	370	466	521	544	608	705	872	1.045	1.179

Base livello 2 cestoni

Sink base unit with 2 deep drawers
Base sous évier 2 paniers
Base fregadero de 2 cestas
2-Schubkasten-Spülenunterschrank

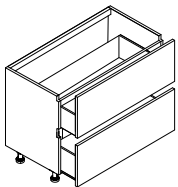

P/D	L/W	CODICE	0	1	2	3	4	5	6	7	8	9	10
57	75	KGL540810754	501	523	534	606	632	682	717	806	986	1.184	1.234
57	90	KGL540810904	554	577	595	657	702	763	798	905	1.110	1.332	1.382
57	105	KGL540811054	636	661	674	757	805	876	910	1.042	1.276	1.529	1.579
57	120	KGL540811204	703	729	766	857	909	967	1.034	1.180	1.441	1.729	1.779
67	75	KGL540810757	598	626	636	707	733	780	819	913	1.123	1.347	1.397
67	90	KGL540810907	652	678	695	755	799	859	897	1.003	1.229	1.476	1.526
67	105	KGL540811057	722	748	759	839	889	959	991	1.125	1.380	1.658	1.708
67	120	KGL540811207	774	799	836	926	978	1.034	1.105	1.247	1.531	1.839	1.889

Basi con maniglia
Base units with handle

Basi con gola
Base units with groove

Colonne
Tall units

Pensili
Wall units

Elementi speciali
Special elements

Maniglie gole zoccoli
Handles grooves plinth

Illuminazione
Lighting

Accessori
Accessories

Componenti e meccanismi
Components e mechanism

BASI CON GOLLA LAVELLO

H. 81

Sink base units with groove
Bases sous évier avec rainure
Bases fregadero con uñero
Spülenunterschranke mit Griffleiste

Base lavello 1 frontale fisso + 1 cestone

Sink base unit 1 fixed front + 1 deep drawer
Base sous évier 1 façade fixe + 1 panier
Base fregadero 1 frente fijo + 1 cajón
Spülenunterschrank 1 feste Front + 1 Schublade

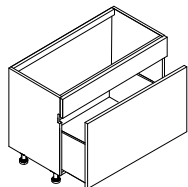

P/D	L/W	CODICE	0	1	2	3	4	5	6	7	8	9	10
57	75	KGL340810754	329	340	355	407	436	448	490	567	701	842	970
57	90	KGL340810904	346	362	381	443	472	491	542	631	779	934	1.098
57	105	KGL340811054	399	415	439	510	543	564	624	726	895	1.075	1.228
57	120	KGL340811204	459	477	505	588	626	649	718	834	1.029	1.237	1.358
67	75	KGL340810757	380	398	407	460	485	499	536	620	763	916	992
67	90	KGL340810907	397	417	432	495	521	537	589	684	841	1.010	1.122
67	105	KGL340811057	436	460	474	544	572	593	647	754	924	1.150	1.253
67	120	KGL340811207	480	506	523	599	631	652	712	827	1.017	1.264	1.385

Base lavello 1 frontale fisso + 1 cassetto + 1 cestone

Sink base unit 1 fixed front + 1 drawer + 1 deep drawer
Base sous évier 1 façade fixe + 1 tiroir + 1 panier
Base fregadero 1 frente fijo + 1 cajón + 1 cajón hondo
Spülenunterschrank 1 feste Front + 1 Schublade + 1 tiefer Auszug

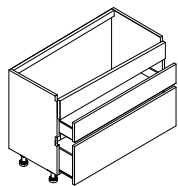

P/D	L/W	CODICE	0	1	2	3	4	5	6	7	8	9	10
57	75	KGL360810754	501	523	534	606	632	682	717	806	986	1.184	1.234
57	90	KGL360810904	554	577	595	657	702	763	798	905	1.110	1.332	1.382
57	105	KGL360811054	636	661	674	757	805	876	910	1.042	1.276	1.529	1.579
57	120	KGL360811204	703	729	766	857	909	967	1.034	1.180	1.441	1.729	1.779
67	75	KGL360810757	598	626	636	707	733	780	819	913	1.123	1.347	1.397
67	90	KGL360810907	652	678	695	755	799	859	897	1.003	1.229	1.476	1.526
67	105	KGL360811057	722	748	759	839	889	959	991	1.125	1.380	1.658	1.708
67	120	KGL360811207	774	799	836	926	978	1.034	1.105	1.247	1.531	1.839	1.889

Base lavello 1 frontale fisso + 1 anta

Sink base unit 1 fixed front + 1 door
Base sous évier 1 façade fixe + 1 porte
Base fregadero 1 frente fijo + 1 puerta
Spülenunterschrank 1 feste Front + 1 Tür

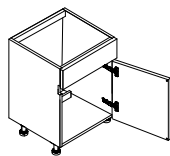

P/D	L/W	CODICE	0	1	2	3	4	5	6	7	8	9	10
57	45	KGL310810454	153	190	208	246	270	274	296	331	408	489	582
57	60	KGL310810604	165	200	222	272	302	303	340	388	482	578	706
67	45	KGL310810457	161	200	215	254	278	283	304	339	420	505	591
67	60	KGL310810607	177	210	233	279	309	312	350	400	493	592	716

BASI CON GOLA LAVELLO

H. 81

Sink base units with groove
Bases sous évier avec rainure
Bases fregadero con uñero
Spülenunterschranke mit Griffleiste

Base livello 1 frontale fisso + 2 ante

Sink base unit 1 fixed front + 2 doors
Base sous évier 1 façade fixe + 2 portes
Base fregadero 1 frente fijo + 2 puertas
Spülenunterschrank 1 feste Front + 2 Türen

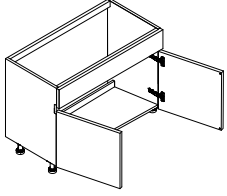

P/D	L/W	CODICE	0	1	2	3	4	5	6	7	8	9	10
57	90	KGL320810904	221	271	304	379	427	447	482	557	687	824	1.062
57	120	KGL320811204	259	310	355	450	507	530	595	692	857	1.027	1.313
67	90	KGL320810907	235	283	318	393	441	459	499	569	705	845	1.073
67	120	KGL320811207	274	323	370	466	521	544	608	705	872	1.045	1.326

Base livello 1 estraibile

Sink base unit 1 pull-out
Base sous évier 1 extractible
Base fregadero 1 extraíble
Spülenunterschrank 1 Auszug

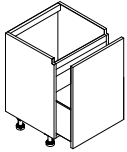

P/D	L/W	CODICE	0	1	2	3	4	5	6	7	8	9	10
57	45	KGL500810454	277	286	297	319	345	373	395	456	563	676	716
57	60	KGL500810604	296	305	313	353	380	406	436	503	624	748	788
57	75	KGL500810754	312	323	339	387	414	448	490	567	701	842	882
67	45	KGL500810457	330	340	346	371	396	427	447	506	629	754	794
67	60	KGL500810607	346	359	365	404	430	459	484	555	686	823	863
67	75	KGL500810757	363	378	387	437	463	499	536	620	763	916	956

Optional copertura lavello in finitura scocca (sp. 1,8 cm H. 13,3 cm)

Optional sink cover in shell finish (1.8 cm thick H 13.3 cm)
Option : couvercle d'évier en finition corps (1,8 cm d'épaisseur H 13,3 cm)
Optional cubierta para fregadero acabado como estructura (1,8 cm de grosor H 13,3 cm)
Optionale Waschbeckenabdeckung in Korpusausführung (1,8 cm dick, H 13,3 cm)

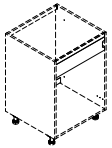

L/W	CODICE	0	1	2	3	4	5	6	7	8	9	10
41,3	JPE0101304118	49	49	49	49	49	49	49	49	49	49	49
56,3	JPE0101305618	49	49	49	49	49	49	49	49	49	49	49
71,3	JPE0101307118	49	49	49	49	49	49	49	49	49	49	49
86,3	JPE0101308618	49	49	49	49	49	49	49	49	49	49	49
101,3	JPE0101310118	49	49	49	49	49	49	49	49	49	49	49
116,3	JPE0101311618	49	49	49	49	49	49	49	49	49	49	49

Basi con maniglia
Base units with handle

Basi con gola
Base units with groove

Colonne
Tall units

Pensili
Wall units

Elementi speciali
Special elements

Maniglie gole zoccoli
Handles grooves plinth

Illuminazione
Lighting

Accessori
Accessories

Componenti e meccanismi
Components e mechanism

BASI CON GOLA ANGOLO

H. 81

Corner groove base units
Bases d'angle avec rainure
Bases ángulo con uñero
Unterschränke mit Ecke Griffleiste

Montante per angolo cieco

Blind corner upright
Montant de l'angle mort
Regleta para ángulo ciego
Eckblende



P/D	L/W	CODICE	0	1	2	3	4	5	6	7	8	9	10
6,5	6,5	KGA90081007C	54	55	56	77	85	96	117	122	153	182	232

Base angolo 1 anta + 1 ripiano

Corner base unit 1 door + 1 shelf
Base d'angle 1 porte + 1 étagère
Base ángulo 1 puerta + 1 balda
Eckschrank 1 Tür + 1 Fachboden

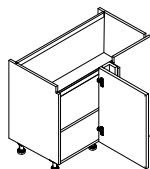

	P/D	L/W	CODICE	0	1	2	3	4	5	6	7	8	9	10
●	42	95	KGA010810951D/S	236	283	323	410	453	480	501	707	729	887	937
○	42	110	KGA010811101D/S	273	320	360	447	490	517	537	744	767	925	975
▲	42	125	KGA010811251D/S	275	322	371	464	512	551	577	799	824	992	1.042
●	65	95	KGA010810954D/S	255	303	342	430	472	500	520	727	749	907	957
○	65	110	KGA010811104D/S	292	340	379	467	509	536	557	637	787	945	995
▲	65	125	KGA010811254D/S	294	341	390	483	532	570	597	682	844	1.012	1.062
●	75	105	KGA010811057D/S	330	379	448	589	654	724	755	1.067	1.100	1.327	1.377
○	75	120	KGA010811207D/S	367	416	485	626	691	760	792	921	1.138	1.365	1.415
▲	75	135	KGA010811357D/S	371	420	493	643	714	793	831	964	1.194	1.433	1.483

- **scocca da 75 cm** | 75 cm body | structure de 75 cm | estructura de 75 cm | 75 cm Korpus
- **scocca da 90 cm** | 90 cm body | structure de 90 cm | estructura de 90 cm | 90 cm Korpus
- ▲ **scocca da 105 cm** | 105 cm body | structure de 105 cm | estructura de 105 cm | 105 cm Korpus

Base angolo 1 anta con meccanismo Linea Pro Sige

Corner base unit 1 door with Linea Pro mechanism
Base d'angle 1 porte avec mécanisme Linea Pro Sige
Base ángulo 1 puerta con mecanismo Linea Pro Sige
Eckschrank 1 Tür mit Mechanismus Linea Pro Sige

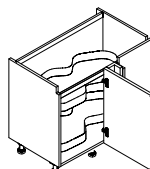

	P/D	L/W	CODICE	0	1	2	3	4	5	6	7	8	9	10
○	65	110	KGA760811104D/S	757	803	820	903	948	993	1.012	1.081	1.244	1.400	1.450
▲	65	125	KGA760811254D/S	816	865	885	979	1.023	1.083	1.110	1.180	1.357	1.526	1.576
○	75	120	KGA760811207D/S	766	813	829	913	957	1.003	1.021	1.090	1.254	1.410	1.460
▲	75	135	KGA760811357D/S	890	943	964	1.109	1.177	1.307	1.344	1.464	1.708	1.947	1.997

- **scocca da 90 cm** | 90 cm body | structure de 90 cm | estructura de 90 cm | 90 cm Korpus
- ▲ **scocca da 105 cm** | 105 cm body | structure de 105 cm | estructura de 105 cm | 105 cm Korpus

Maggiorazione per meccanismo Linea Pure Kessebohrer PUNTI 269

Mechanism Pure Kessebohrer Line | Supplément pour le mécanisme Linea Pure Kessebohrer | Recargo para mecanismo Linea Pure Kessebohrer | Aufpreis für Mechanismus Pure Kessebohrer Line

BASI CON GOLLA ANGOLO

Corner groove base units
Bases d'angle avec rainure
Bases ángulo con uñero
Unterschranke mit Ecke Griffleiste

H. 81

Base angolo 2 ante (su fianchi) + 1 ripiano

Corner base unit 2 doors (on sides) + 1 shelf
Base d'angle 2 portes (sur les côtés) + 1 étagère
Base ángulo 2 puertas (laterales) + 1 balda
Eckschrank 2 Türen (an den Seiten) + 1 Regal

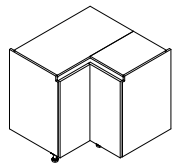

P/D	L/W	CODICE	0	1	2	3	4	5	6	7	8	9	10
95	95	KGA02081095A	430	463	474	546	569	609	629	751	929	1.114	1.164
105	105	KGA02081105B	464	471	517	587	612	646	671	764	946	1.134	1.184

Base livello angolo 1 anta

Corner sink base unit 1 door
Base sous evier d'angle 1 porte
Base fregadero ángulo 1 puerta
Eckspülenunterschrank 1 Tür

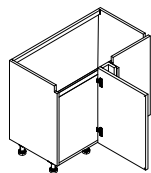

	P/D	L/W	CODICE	0	1	2	3	4	5	6	7	8	9	10
●	65	95	KGB010810954D/S	272	305	321	380	414	442	460	536	666	792	902
○	65	110	KGB010811104D/S	281	314	331	390	424	452	469	546	676	812	912
▲	65	125	KGB010811254D/S	287	321	343	410	448	478	511	588	727	874	974
●	75	105	KGB010811057D/S	277	311	328	388	423	453	470	549	680	818	917
○	75	120	KGB010811207D/S	287	321	338	398	433	463	480	559	690	827	927
▲	75	135	KGB010811357D/S	294	329	350	420	458	490	524	600	743	890	990

- **scocca da 75 cm** | 75 cm body | structure de 75 cm | estructura de 75 cm | 75 cm Korpus
- **scocca da 90 cm** | 90 cm body | structure de 90 cm | estructura de 90 cm | 90 cm Korpus
- ▲ **scocca da 105 cm** | 105 cm body | structure de 105 cm | estructura de 105 cm | 105 cm Korpus

Basi con maniglia
Base units with handle

Basi con gola
Base units with groove

Colonne
Tall units

Pensili
Wall units

Elementi speciali
Special elements

Maniglie gole zoccoli
Handles grooves plinth

Illuminazione
Lighting

Accessori
Accessories

Componenti e meccanismi
Components e mechanism

ANTE E STRUTTURE PER ELETTRODOMESTICI

H. 81

Doors and frames for household appliances
Portes et structures pour électroménagers
Puertas y estructuras para electrodomésticos
Türen und Rahmen für Elektrogeräte

Anta gola per lavastoviglie con comandi a scomparsa totale (sliding)

Door with groove for dishwashers with fully concealed controls (sliding)
Porte à rainure pour lave-vaisselle à commandes entièrement dissimulées (coulissante)
Puerta GOLLA para lavavajillas con mandos totalmente ocultos (deslizantes)
Tür mit Griffleiste für Geschirrspüler mit vollständig verdeckten Bedienelementen (Schiebetür)

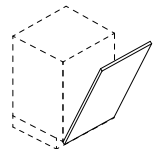

L/W	CODICE	0	1	2	3	4	5	6	7	8	9	10
45	KAL02081045	71	79	99	134	153	191	218	230	312	367	420
60	KAL02081060	73	81	108	150	178	226	262	264	375	444	511

Anta gola per lavastoviglie con comandi a scomparsa totale (con fisso inferiore)

Door with groove for integral washing machine with total concealed controls (with lower fixed)
Porte à rainure pour lave-vaisselle à commandes totalement cachées (avec fixe inférieur)
Puerta GOLLA para lavavajillas con mandos totalmente ocultos (con fijo inferior)
Tür mit Griffleiste für Geschirrspüler mit vollständig verdeckten Bedienelementen (mit unterer Befestigung)

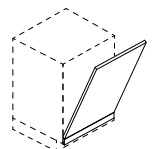

L/W	CODICE	0	1	2	3	4	5	6	7	8	9	10
45	KAL04081045	79	85	105	140	161	177	202	237	286	338	461
60	KAL04081060	92	102	127	181	209	236	286	331	403	478	564

Anta gola per frigo o congelatore autoportanti

Door with groove for fridge with hinges self-supporting
Porte frigo ou congélateur autoportante
Puerta GOLLA para frigorífico o congelador autoportantes
Freistehende Kühl- oder Gefrier Tür mit Griffleiste

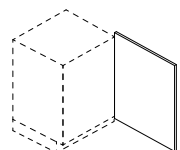

L/W	CODICE	0	1	2	3	4	5	6	7	8	9	10
60	KAF02081060	73	81	108	150	178	226	262	264	375	444	511

ANTE E STRUTTURE PER ELETTRODOMESTICI

H. 81

Doors and frames for household appliances
Portes et structures pour électroménagers
Puertas y estructuras para electrodomésticos
Türen und Rahmen für Elektrogeräte

Struttura gola per frigorifero o congelatore traino

Throat frame for towing refrigerator or freezer
Cadre de gorge pour le remorquage d'un réfrigérateur ou d'un congélateur
Estructura con uñero para nevera o freezer
Kehlrahmen zum Ziehen von Kühl- oder Gefriergeräten

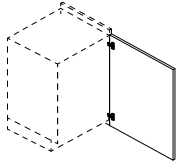

L/W	CODICE	0	1	2	3	4	5	6	7	8	9	10
60	KAF04081060	105	113	146	194	225	245	280	327	393	461	519

Anta gola per lavatrice integrale

Door with groove for integral washing machine
Porte à rainure pour machine à laver intégrée
Puerta GOLA para lavadora integral
tür mit Griffleiste für integrierte Waschmaschine

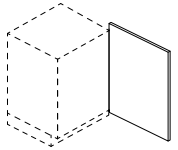

L/W	CODICE	0	1	2	3	4	5	6	7	8	9	10
60	KAL06081060	73	81	108	150	178	226	262	264	375	444	511

Anta lavastoviglie con gola intermedia e telaio strutturale (372+372)

Dishwasher door with middle groove and structural frame (372+372)
Porte lave-vaisselle avec rainure intermédiaire et cadre structurel (372+372)
Puerta lavavajillas con uñero intermedio y marco estructural (372+372)
Spülmaschinentür mit Zwischen Griffleiste und Konstruktionsrahmen (372+372)

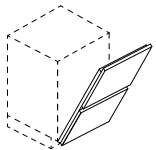

L/W	CODICE	0	1	2	3	4	5	6	7	8	9	10
60	KAL07081060	242	251	281	331	362	380	415	476	549	625	675

Basi con maniglia
Base units with handle

Basi con gola
Base units with groove

Colonne
Tall units

Pensili
Wall units

Elementi speciali
Special elements

Maniglie gole zoccoli
Handles grooves plinth

Illuminazione
Lighting

Accessori
Accessories

Componenti e meccanismi
Components e mechanism

ANTE E STRUTTURE PER ELETTRODOMESTICI

H. 81

Doors and frames for household appliances
Portes et structures pour électroménagers
Puertas y estructuras para electrodomésticos
Türen und Rahmen für Elektrogeräte

Anta lavastoviglie con gola intermedia e telaio strutturale (585+195)

Dishwasher door with middle groove and structural frame (585+195)
Porte lave-vaisselle avec rainure intermédiaire et cadre structurel (585+195)
Puerta lavavajillas con uñero intermedio y marco estructural (585+195)
Spülmaschinentür mit Zwischen Griffleisyteund Konstruktionsrahmen (585+195)

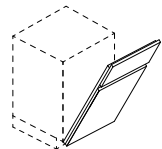

L/W	CODICE	0	1	2	3	4	5	6	7	8	9	10
60	KAL08081060	242	251	281	331	362	380	415	476	549	625	675

Base gola per frigorifero da incasso

Groove base unit for built-in refrigerator
Base rainure pour réfrigérateur encastré
Base con uñero para frigorífico empotrado
Kehlsockel für Einbaukühlschrank

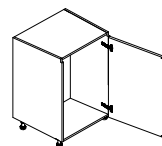

P/D	L/W	CODICE	0	1	2	3	4	5	6	7	8	9	10
57	60	KAF060810604	149	177	182	209	216	235	249	274	330	396	446
67	60	KAF060810607	164	190	192	227	233	245	264	287	343	412	462

COLONNE

Tall units
Colonne
Columnas
Hochschranke

H. 99	P. 91
<ul style="list-style-type: none"> COLONNE Tall units Colonne Columnas Hochschranke COLONNE FORNO Oven tall units Colonne four Columnas horno Backofen-Hochschranke 	<p>P. 91</p> <p>P. 92</p>
H. 132	P. 93
<ul style="list-style-type: none"> COLONNE Tall units Colonne Columnas Hochschranke COLONNE FORNO Oven tall units Colonne four Columnas horno Backofen-Hochschranke COLONNE FRIGO Fridge tall units Colonne frigo Columnas nevera Kühlschrank Hochschranke COLONNE VETRINA Showcase tall units Vitrine Columnas vitrina Glasstuer Hochschranke 	<p>P. 93</p> <p>P. 96</p> <p>P. 98</p> <p>P. 99</p>
H. 195	P. 100
<ul style="list-style-type: none"> COLONNE Tall units Colonne Columnas Hochschranke COLONNE FORNO Oven tall units Colonne four Columnas horno Backofen-Hochschranke COLONNE FRIGO Fridge tall units Colonne frigo Columnas nevera Kühlschrank Hochschranke COLONNE VETRINA Showcase tall units Vitrine Columnas vitrina Glasstuer Hochschranke COLONNE USA USA tall units Colonne américaines Columnas USA US-Hochschranke 	<p>P. 100</p> <p>P. 111</p> <p>P. 117</p> <p>P. 118</p> <p>P. 119</p>
H. 210	P. 120
<ul style="list-style-type: none"> COLONNE Tall units Colonne Columnas Hochschranke COLONNE FORNO Oven tall units Colonne four Columnas horno Backofen-Hochschranke COLONNE FRIGO Fridge tall units Colonne frigo Columnas nevera Kühlschrank Hochschranke COLONNE VETRINA Showcase tall units Vitrine Columnas vitrina Glasstuer Hochschranke COLONNE USA USA tall units Colonne américaines Columnas USA US-Hochschranke 	<p>P. 120</p> <p>P. 131</p> <p>P. 137</p> <p>P. 138</p> <p>P. 139</p>
H. 225	P. 140
<ul style="list-style-type: none"> COLONNE Tall units Colonne Columnas Hochschranke COLONNE FORNO Oven tall units Colonne four Columnas horno Backofen-Hochschranke COLONNE FRIGO Fridge tall units Colonne frigo Columnas nevera Kühlschrank Hochschranke COLONNE VETRINA Showcase tall units Vitrine Columnas vitrina Glasstuer Hochschranke COLONNE USA USA tall units Colonne américaines Columnas USA US-Hochschranke 	<p>P. 140</p> <p>P. 151</p> <p>P. 157</p> <p>P. 158</p> <p>P. 159</p>
H. 240	P. 160
<ul style="list-style-type: none"> COLONNE Tall units Colonne Columnas Hochschranke COLONNE FORNO Oven tall units Colonne four Columnas horno Backofen-Hochschranke COLONNE FRIGO Fridge tall units Colonne frigo Columnas nevera Kühlschrank Hochschranke COLONNE USA USA tall units Colonne américaines Columnas USA US-Hochschranke 	<p>P. 160</p> <p>P. 171</p> <p>P. 177</p> <p>P. 178</p>
PENSILI SOPRACOLONNA	P. 179
Overhead cabinets Armoires suspendues Colgantes apilables para columna Hängeschranke	
COLONNE COMPOSTE	P. 185
Compound tall units Colonne composées Columnas compuestas Zusammengesetzte Hochschranke	

Basi con maniglia
Base units with handle

Basi con gola
Base units with groove

Colonne
Tall units

Pensili
Wall units

Elementi speciali
Special elements

Maniglie gole zoccoli
Handles grooves plinth

Illuminazione
Lighting

Accessori
Accessories

Componenti e meccanismi
Components e mechanism

MAGGIORAZIONI COLONNE

Tall units surcharges
Surtaxe de colonne
Recargos por columna
Säulenzuschläge

Consulta l'elenco completo delle maggiorazioni a pag. 30

See the full list of surcharges on page 30

Voir la liste complète des suppléments à la page 30

Consulte la lista completa de recargos a la página 30

Siehe die vollständige Liste der Zuschläge auf Seite 30

MAGGIORAZIONI ENHANCEMENTS SUPPLÉMENTS RECARGOS AUFPREISEN	PUNTI POINTS POINTS PUNTOS PUNKTE
APERTURA ELETTRICA ANTA DOPPIA For electric double sash opening Pour l'ouverture électrique de la double porte Para apertura eléctrica de puerta doble Für elektrische Doppeltüröffnung	934
APERTURA ELETTRICA ANTA SINGOLA For single sash electric opening Pour ouverture électrique à un vantail Para apertura eléctrica de una hoja Für einflügelige elektrische Öffnung	467
TRASFORMATORE PER APERTURA ELETTRICA 220V (UE) / 110V (UL - USA) Transformer for electrical opening 220V (EU) / 110V (UL - USA) Transformateur pour ouverture électrique 220V (EU) / 110V (UL - USA) Transformador para apertura eléctrica 220V (EU) / 110V (UL - USA) Transformator für elektrische Öffnung 220V (EU) / 110V (UL - USA)	164
APERTURA ELETTRICA E-TOUCH For electric E-touch opening Pour l'ouverture électrique E-touch Para apertura eléctrica E-touch Für elektrische E-touch-Öffnung	1.046
MECCANISMO LINEA PURE PER ESTRAIBILE L. 30 KESSEBOHMER For Linea Pure mechanism for pull-out L. 30 Kessebohmer Pour mécanisme Pure Line pour pull-out L. 30 Kessebohmer Para mecanismo Pure Line para extracción L. 30 Kessebohmer Für Mechanik Pure Line für Auszug L. 30 Kessebohmer	195
MECCANISMO LINEA PURE PER ESTRAIBILE L. 45 KESSEBOHMER For Linea Pure mechanism for pull-out L. 45 Kessebohmer Pour le mécanisme Pure Line pour l'extraction L. 45 Kessebohmer Para mecanismo Pure Line para extracción L. 45 Kessebohmer Für Mechanik Pure Line für Auszug L. 45 Kessebohmer	305
MECCANISMO LINEA PURE PER ANTA L. 45 KESSEBOHMER Surcharge for Linea Pure mechanism for door L. 45 Kessebohmer Supplément pour Linea Mécanisme pur pour porte L. 45 Kessebohmer Recargo por mecanismo Linea Pure para puerta L. 45 Kessebohmer Aufpreis für Linea Pure Mechanismus für Tür L. 45 Kessebohmer	438
MECCANISMO LINEA PURE PER ANTA L. 60 KESSEBOHMER For Linea Pure mechanism for door L. 60 Kessebohmer Pour mécanisme Pure Line pour porte L. 60 Kessebohmer Para mecanismo Pure Line para puerta L. 60 Kessebohmer Für Mechanismus Pure Line für Tür L. 60 Kessebohmer	657
MECCANISMO LINEA PURE PER ANGOLO KESSEBOHMER For Linea Pure mechanism for Kessebohmer corner Pour le mécanisme Pure Line pour l'angle Kessebohmer Para el mecanismo Linea Pura para el ángulo Kessebohmer Für Mechanismus Pure Line für Kessebohmer Winkel	645
MECCANISMO ARENA STYLE KESSEBOHMER Mechanism Arena Style Kessebohmer Pour le mécanisme Arena Style Kessebohmer Para mecanismo Arena Style Kessebohmer Für Mechanismus Arena Style Kessebohmer	857
MECCANISMO LINEA PURE PER COLONNA ANGOLO KESSEBOHMER Linea Pure mechanism for Kessebohmer corner tall units Pour Linea Pure mécanisme pour colonne d'angle Kessebohmer Para mecanismo Linea Pure para columna angular Kessebohmer Für Linea Pure Mechanik für Kessebohmer Ecksäule	269

COLONNE

Tall units
Colonnes
Columnas
Hochschränke

H. 99

Colonna 1 anta

Tall unit 1 door
Colonne 1 porte
Columna 1 puerta
Hochschrank 1 Tür

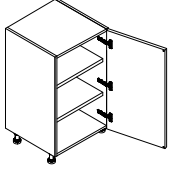

P/D	L/W	CODICE	0	1	2	3	4	5	6	7	8	9	10
57	45	KCN010990454	178	210	237	265	345	410	433	448	515	616	666
57	60	KCN010990604	198	221	258	299	333	374	410	496	613	736	748
67	45	KCN010990457	189	221	250	276	358	424	447	463	527	633	683
67	60	KCN010990607	210	236	274	311	345	386	424	507	625	751	767

Colonna 2 ante

Tall unit 2 doors
Colonne 2 portes
Columna 2 puertas
Hochschrank 2 Türen

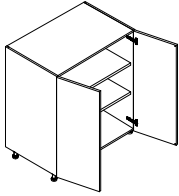

P/D	L/W	CODICE	0	1	2	3	4	5	6	7	8	9	10
57	90	KCN020990904	278	309	350	404	434	503	570	656	812	973	1.181
67	90	KCN020990907	290	320	362	417	446	516	583	666	827	993	1.206

Basi con maniglia
Base units with handle

Basi con gola
Base units with groove

Colonne
Tall units

Pensili
Wall units

Elementi speciali
Special elements

Maniglie gole zoccoli
Handles grooves plinth

Illuminazione
Lighting

Accessori
Accessories

Componenti e meccanismi
Components e mechanism

COLONNE FORNO

Oven tall units
Colonne four
Columnas horno
Backofen-Hochschränke

H. 99

Colonna forno 1 cestone

Oven tall unit 1 drawer
Colonne four 1 oancier
Columna horno 1 cajón hondo
Backofenschrank 1 Schublade

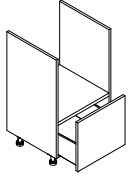

P/D	L/W	CODICE	0	1	2	3	4	5	6	7	8	9	10
57	60	KC0500990604	319	369	395	429	443	444	452	506	592	711	761
67	60	KC0500990607	337	383	409	443	460	463	468	521	610	730	780

COLONNE

Tall units
Colonnes
Columnas
Hochschränke

H. 132

Riempitivo per colonna

Tall unit filler
Fileur pour colonne
Regleta para columna
Hochschrankfüller



L/W	CODICE	0	1	2	3	4	5	6	7	8	9	10
4-15	KCN901320151	114	128	155	179	190	200	215	258	319	383	423

Colonna 1 anta

Tall unit 1 door
Colonne 1 porte
Columna 1 puerta
Hochschrank 1 Tür

Apertura con gola verticale o maniglia
Opening with vertical groove or handle
Ouverture avec rainure verticale ou poignée
Apertura con uñero vertical o tirador
Öffnung mit vertikaler Griffleiste

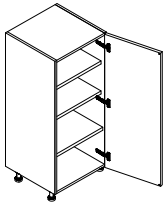

P/D	L/W	CODICE	0	1	2	3	4	5	6	7	8	9	10
34	30	KCN011320301	217	238	289	313	336	365	391	453	563	681	739
34	45	KCN011320451	243	263	314	339	361	390	416	478	589	707	765
34	60	KCN011320601	255	278	340	380	408	430	485	559	687	824	923
34	75	KCN011320751	268	291	352	393	421	442	498	571	700	837	936
57	30	KCN011320304	276	305	368	399	424	464	496	572	711	858	908
57	45	KCN011320454	302	330	393	424	449	489	521	598	737	884	934
57	60	KCN011320604	320	347	424	474	509	535	606	697	858	1.030	1.080
57	75	KCN011320754	333	360	437	487	522	548	619	710	871	1.043	1.093
67	30	KCN011320307	291	319	384	414	442	477	510	587	728	879	929
67	45	KCN011320457	316	344	409	439	468	502	535	612	754	905	955
67	60	KCN011320607	337	364	437	491	525	550	621	712	876	1.051	1.101
67	75	KCN011320757	349	376	450	503	537	563	633	725	889	1.064	1.114

Colonna 2 ante

Tall unit 2 doors
Colonne 2 portes
Columna 2 puertas
Hochschrank 2 Türen

Apertura solo con maniglia
Opening with handle only
Ouverture seulement avec la poignée
Apertura sólo con tirador
Öffnung nur mit Griff

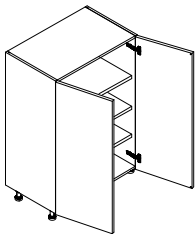

P/D	L/W	CODICE	0	1	2	3	4	5	6	7	8	9	10
34	90	KCN021320901	370	410	443	510	553	577	626	768	951	1.143	1.462
57	90	KCN021320904	381	459	578	682	737	784	851	1.027	1.267	1.520	1.570
67	90	KCN021320907	404	478	600	703	760	801	871	1.048	1.290	1.549	1.599

Basi con maniglia
Base units with handle

Basi con gola
Base units with groove

Colonne
Tall units

Pensili
Wall units

Elementi speciali
Special elements

Maniglie gole zoccoli
Handles grooves plinth

Illuminazione
Lighting

Accessori
Accessories

Componenti e meccanismi
Components e mechanism

COLONNE

Tall units
Colonne
Columnas
Hochschranke

H. 132

Colonna 1 anta + 2 cestoni + 2 cassetti interni

Tall unit 1 door + 2 baskets + 2 internal drawers
Colonne 1 porte + 2 paniers + 2 tiroirs intérieurs
Columna 1 puerta + 2 cestas + 2 cajones interiores
Hochschrank 1 Tür + 2 Schubkasten + 2 Innenschubladen

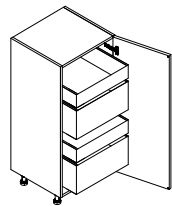

Apertura con gola verticale o maniglia
Opening with vertical groove or handle
Ouverture avec rainure verticale ou poignée
Apertura con uñero vertical o tirador
Öffnung mit vertikaler Griffleiste

P/D	L/W	CODICE	0	1	2	3	4	5	6	7	8	9	10
57	45	KCK121320454	550	617	662	730	758	771	781	903	1.107	1.328	1.378
57	60	KCK121320604	646	733	815	896	953	964	1.000	1.107	1.367	1.639	1.689
67	45	KCK121320457	656	724	772	843	865	874	887	1.011	1.240	1.487	1.537
67	60	KCK121320607	832	922	1.008	1.096	1.142	1.161	1.187	1.293	1.600	1.919	1.969

Colonna 1 estraibile con meccanismo Linea Pro Sige

Tall unit 1 pull-out with mechanism Linea Pro Sige
Colonne 1 extractible avec mécanisme Linea Pro Sige
Columna 1 extraíble con mecanismo Linea Pro Sige
Hochschrank 1 Auszug mit Mechanismus Linea Pro Sige

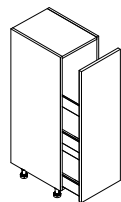

Apertura con gola verticale o maniglia
Opening with vertical groove or handle
Ouverture avec rainure verticale ou poignée
Apertura con uñero vertical o tirador
Öffnung mit vertikaler Griffleiste

P/D	L/W	CODICE	0	1	2	3	4	5	6	7	8	9	10
57	30	KCN701320304	688	751	772	814	849	861	891	964	1.201	1.441	1.498
67	30	KCN701320307	702	763	79	826	861	876	906	980	1.218	1.461	1.512

Maggiorazione per meccanismo Linea Pure Kessebohrer PUNTI 195

Mechanism Pure Kessebohrer Line | Supplément pour le mécanisme Linea Pure Kessebohrer | Recargo para mecanismo Linea Pure Kessebohrer | Aufpreis für Mechanismus Pure Kessebohrer Line

Colonna 1 estraibile con meccanismo Linea Pro Sige

Tall unit 1 pull-out with mechanism Linea Pro Sige
Colonne 1 extractible avec mécanisme Linea Pro Sige
Columna 1 extraíble con mecanismo Linea Pro Sige
Hochschrank 1 Auszug mit Mechanismus Linea Pro Sige

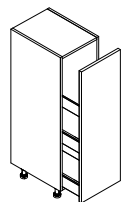

Apertura con gola verticale o maniglia
Opening with vertical groove or handle
Ouverture avec rainure verticale ou poignée
Apertura con uñero vertical o tirador
Öffnung mit vertikaler Griffleiste

P/D	L/W	CODICE	0	1	2	3	4	5	6	7	8	9	10
57	45	KCN701320454	717	784	826	863	911	922	978	1.080	1.341	1.608	1.795
67	45	KCN701320457	729	797	841	879	922	938	990	1.091	1.359	1.629	1.811

Maggiorazione per meccanismo Linea Pure Kessebohrer PUNTI 305

Mechanism Pure Kessebohrer Line | Supplément pour le mécanisme Linea Pure Kessebohrer | Recargo para mecanismo Linea Pure Kessebohrer | Aufpreis für Mechanismus Pure Kessebohrer Line

COLONNE

Tall units
Colonnes
Columns
Hochschränke

H. 132

Colonna angolo 1 anta
Corner tall unit 1 door
Colonne d'angle 1 porte
Columna ángulo 1 puerta
Eckehochschrank 1 Tür

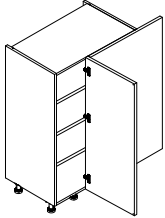

Apertura con gola verticale o maniglia
Opening with vertical groove or handle
Ouverture avec rainure verticale ou poignée
Apertura con uñero vertical o tirador
Öffnung mit vertikaler Griffleiste

	P/D	L/W	CODICE	0	1	2	3	4	5	6	7	8	9	10
○	36,5	110	KCA011321101D/S	564	609	705	791	867	956	1.061	1.101	1.351	1.629	1.729
▲	36,5	120	KCA011321201D/S	585	642	760	849	922	1.034	1.082	1.164	1.473	1.775	1.875
○	59,5	110	KCA011321104D/S	601	647	743	828	905	994	1.099	1.139	1.390	1.668	1.768
▲	59,5	120	KCA011321204D/S	623	680	797	887	959	1.072	1.119	1.202	1.512	1.814	1.914
○	69,5	110	KCA011321107D/S	621	666	766	854	933	1.023	1.132	1.173	1.432	1.718	1.818
▲	69,5	120	KCA011321207D/S	640	700	821	914	986	1.105	1.152	1.238	1.556	1.866	1.966

- **scocca da 90 cm** | 90 cm body | structure de 90 cm | estructura de 90 cm | 90 cm Korpus
▲ **scocca da 105 cm** | 105 cm body | structure de 105 cm | estructura de 105 cm | 105 cm Korpus

Colonna angolo 1 anta con meccanismo Linea Pro Sige
Corner tall unit 1 door with mechanism Linea Pro Sige
Colonne d'angle 1 porte avec mécanisme Linea Pro Sige
Columna ángulo 1 puerta con mecanismo Linea Pro Sige
Eckehochschrank 1 Tür mit Mechanismus Linea Pro Sige

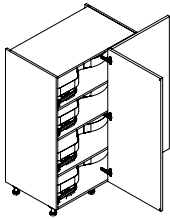

Apertura con gola verticale o maniglia
Opening with vertical groove or handle
Ouverture avec rainure verticale ou poignée
Apertura con uñero vertical o tirador
Öffnung mit vertikaler Griffleiste

	P/D	L/W	CODICE	0	1	2	3	4	5	6	7	8	9	10
○	59,5	110	KCA761321104D/S	1.427	1.471	1.566	1.647	1.722	1.806	1.913	1.987	2.218	2.663	2.837
▲	59,5	125	KCA761321254D/S	1.561	1.617	1.730	1.818	1.887	1.997	2.043	2.122	2.453	2.943	3.102
○	69,5	120	KCA761321207D/S	1.524	1.568	1.663	1.744	1.819	1.903	2.010	2.084	2.318	2.763	2.937
▲	69,5	135	KCA761321357D/S	1.658	1.714	1.827	1.915	1.984	2.094	2.140	2.219	2.553	3.043	3.202

- **scocca da 90 cm** | 90 cm body | structure de 90 cm | estructura de 90 cm | 90 cm Korpus
▲ **scocca da 105 cm** | 105 cm body | structure de 105 cm | estructura de 105 cm | 105 cm Korpus

Maggiorazione per meccanismo Linea Pure Kessebohmer PUNTI 645
Mechanism Pure Kessebohmer Line | Supplément pour le mécanisme Linea Pure Kessebohmer | Recargo para mecanismo Linea Pure Kessebohmer | Aufpreis für Mechanismus Pure Kessebohmer Line

Colonna 1 anta copriboiler
Tall unit 1 door for water header / boiler
Colonne 1 porte pour cumulus
Columna 1 puerta para cubrir un boiler
Abdeckung der Wasser-warme

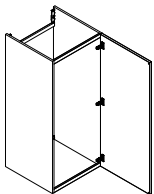

Apertura con gola verticale o maniglia
Opening with vertical groove or handle
Ouverture avec rainure verticale ou poignée
Apertura con uñero vertical o tirador
Öffnung mit vertikaler Griffleiste

	P/D	L/W	CODICE	0	1	2	3	4	5	6	7	8	9	10
	57	60	KCD011320604	210	238	276	340	349	395	442	536	665	839	889
	67	60	KCD011320607	221	249	288	351	361	406	454	548	677	851	901

Basi con maniglia
Base units with handle

Basi con gola
Base units with groove

Colonne
Tall units

Pensili
Wall units

Elementi speciali
Special elements

Maniglie gole zoccoli
Handles grooves plinth

Illuminazione
Lighting

Accessori
Accessories

Componenti e meccanismi
Components e mechanism

COLONNE FORNO

Oven tall units
Colonnes four
Columnas horno
Backofen-Hochschränke

H. 132

Colonna forno 1 anta

Oven tall unit 1 door
Colonne four 1 porte
Columna horno 1 puerta
Backofenschrank 1 Tür

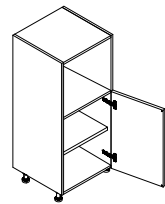

Apertura con gola verticale o maniglia
Opening with vertical groove or handle
Ouverture avec rainure verticale ou poignée
Apertura con uñero vertical o tirador
Öffnung mit vertikaler Griffleiste

	P/D	L/W	CODICE	0	1	2	3	4	5	6	7	8	9	10
	57	60	KC0011320604	245	305	327	378	404	430	444	512	636	761	811
<input type="checkbox"/>	57	75	KC0011320754	294	353	375	427	452	478	493	561	686	811	861
	67	60	KC0011320607	258	320	340	393	417	442	461	528	651	782	832
<input type="checkbox"/>	67	75	KC0011320757	307	369	389	441	466	491	509	576	701	832	882

forno L 75 cm | oven L 75 cm | four L 75 cm | horno L 75 cm | backofen B 75 cm

Colonna forno 1 estraibile + 1 cestone interno

Oven tall unit 1 drawer + 1 inner basket
Colonne four 1 extractible + 1 panier intérieur
Columna horno 1 cajón + 1 cajón hondo interior
Backofenschrank 1 Schublade + 1 Innenschublade

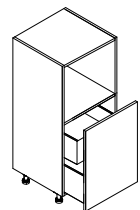

Apertura con gola verticale o maniglia
Opening with vertical groove or handle
Ouverture avec rainure verticale ou poignée
Apertura con uñero vertical o tirador
Öffnung mit vertikaler Griffleiste

	P/D	L/W	CODICE	0	1	2	3	4	5	6	7	8	9	10
	57	60	KC0531320604	435	517	528	581	603	630	649	716	843	1.010	1.060
<input type="checkbox"/>	57	75	KC0531320754	483	566	576	630	652	678	697	764	893	1.060	1.110
	67	60	KC0531320607	530	619	624	675	702	727	743	812	945	1.132	1.182
<input type="checkbox"/>	67	75	KC0531320757	578	667	672	724	751	775	792	860	995	1.182	1.232

forno L 75 cm | oven L 75 cm | four L 75 cm | horno L 75 cm | backofen B 75 cm

Colonna forno 1 estraibile + 2 cassetti interni

Oven tall unit 1 pull-out + 2 internal drawers
Colonne four 1 extractible + 2 tiroirs intérieurs
Columna horno 1 extraíble + 2 cajones interiores
Backofenschrank 1 Auszug + 2 Innenschubladen

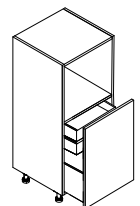

Apertura con gola verticale o maniglia
Opening with vertical groove or handle
Ouverture avec rainure verticale ou poignée
Apertura con uñero vertical o tirador
Öffnung mit vertikaler Griffleiste

	P/D	L/W	CODICE	0	1	2	3	4	5	6	7	8	9	10
	57	60	KC0521320604	483	566	576	630	652	678	697	764	893	1.060	1.110
<input type="checkbox"/>	57	75	KC0521320754	532	614	625	678	700	727	746	813	943	1.110	1.160
	67	60	KC0521320607	578	667	672	724	751	775	792	860	995	1.182	1.232
<input type="checkbox"/>	67	75	KC0521320757	627	716	721	772	799	824	840	909	1.045	1.232	1.282

forno L 75 cm | oven L 75 cm | four L 75 cm | horno L 75 cm | backofen B 75 cm

COLONNE FORNO

Oven tall units
Colonne four
Columnas horno
Backofen-Hochschranke

H. 132

Colonna forno + microonde 1 cestone

Tall unit oven + microwave 1 drawer
Colonne four + micro 1 panier
Horno columna + microondas 1 cajón
Schrankofen + Mikrowelle 1 Schublade

Apertura con gola verticale o maniglia
Opening with vertical groove or handle
Ouverture avec rainure verticale ou poignée
Apertura con uñero vertical o tirador
Öffnung mit vertikaler Griffleiste

P/D	L/W	CODICE	0	1	2	3	4	5	6	7	8	9	10
57	60	KCM501320604	358	405	436	481	511	529	561	629	772	925	975
67	60	KCM501320607	424	469	503	552	589	600	627	695	841	1.008	1.058

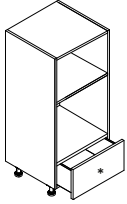

* **Frontale su misura** | Customised front panel | Façade sur mesure | Frente medida especial | Fronten in Sondermasse

Basi con maniglia
Base units with handle

Basi con gola
Base units with groove

Colonne
Tall units

Pensili
Wall units

Elementi speciali
Special elements

Maniglie gole zoccoli
Handles grooves plinth

Illuminazione
Lighting

Accessori
Accessories

Componenti e meccanismi
Components e mechanism

COLONNE FRIGO

Fridge tall units
Colonne frigo
Columnas nevera
Kühlschrank Hochschranke

H. 132

Colonna frigo 1 anta

Refrigerator tall unit 1-door
Colonne frigo 1 porte
Columna nevera 1 puerta
1-türige Kühlschrank Hochschrank

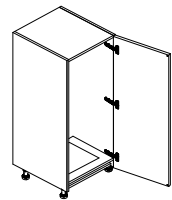

Apertura con gola verticale o maniglia
Opening with vertical groove or handle
Ouverture avec rainure verticale ou poignée
Apertura con uñero vertical o tirador
Öffnung mit vertikaler Griffleiste

P/D	L/W	CODICE	0	1	2	3	4	5	6	7	8	9	10
57	60	KCF011320604	312	343	423	473	505	533	602	695	856	1.027	1.077
67	60	KCF011320607	326	358	437	491	524	547	620	706	877	1.052	1.102

Maggiorazione per apertura elettrica anta singola PUNTI 467

Surcharge for electric single door opening | Supplément pour ouverture électrique d'une porte seule | Recargo para apertura eléctrica puerta singular | Aufpreis für elektrische Türöffnung

COLONNE VETRINA

Showcase tall units
Vitrine
Columnas vitrina
Glasstuer Hochschränke

H. 132

Colonna vetrina 1 anta

Display tall unit 1 door
Vitrine 1 porte
Columna vitrina 1 puerta
Vitrinsäule 1 Tür

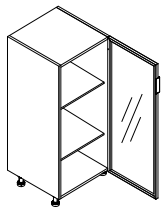

P/D	L/W	CODICE	0	1	2	3	4	5	6	7	8	9	10
34	45	KCV011320451	515	554	696	948	-	-	-	-	-	-	-
34	60	KCV011320601	584	628	789	1.075	-	-	-	-	-	-	-
57	45	KCV011320454	548	589	740	1.009	-	-	-	-	-	-	-
57	60	KCV011320604	635	683	857	1.168	-	-	-	-	-	-	-
67	45	KCV011320457	564	607	762	1.038	-	-	-	-	-	-	-
67	60	KCV011320607	652	701	881	1.200	-	-	-	-	-	-	-

Colonna vetrina 2 ante

Display tall unit 2 doors
Vitrine 2 portes
Columna vitrina 2 puertas
Hochschrank 2 Glasstüren

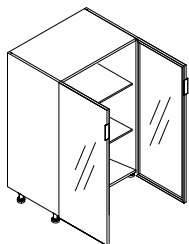

P/D	L/W	CODICE	0	1	2	3	4	5	6	7	8	9	10
34	90	KCV021320901	992	1.066	1.339	1.825	-	-	-	-	-	-	-
57	90	KCV021320904	1.009	1.085	1.363	1.857	-	-	-	-	-	-	-
67	90	KCV021320907	1.030	1.107	1.390	1.894	-	-	-	-	-	-	-

Basi con maniglia
Base units with handle

Basi con gola
Base units with groove

Colonne
Tall units

Pensili
Wall units

Elementi speciali
Special elements

Maniglie gole zoccoli
Handles grooves plinth

Illuminazione
Lighting

Accessori
Accessories

Componenti e meccanismi
Components e mechanism

COLONNE

Tall units
Colonnes
Columnas
Hochschranke

H. 195

Riempitivo per colonna

Tall unit filler
Fileur pour colonne
Regleta para columna
Hochschrankfüller



L/W	CODICE	0	1	2	3	4	5	6	7	8	9	10
4-15	KCN901950151	142	158	185	239	250	259	286	344	425	510	560

Riempitivo per colonna 2 frontali

Tall unit filler 2 fronts
fileur pour colonnes 2 façades
Regleta para columna 2 frentes
Hochschrankfüller 2 Fronten



L/W	CODICE	0	1	2	3	4	5	6	7	8	9	10
4-15	KCN921950151	146	161	190	244	258	268	296	354	438	525	575

Riempitivo per colonna 2 frontali

Tall unit filler 2 fronts
fileur pour colonnes 2 façades
Regleta para columna 2 frentes
Hochschrankfüller 2 Fronten



L/W	CODICE	0	1	2	3	4	5	6	7	8	9	10
4-15	KCN911950151	146	161	190	244	258	268	296	354	438	525	575

COLONNE

Tall units
Colonnes
Columnas
Hochschränke

H. 195

Colonna 1 anta

Tall unit 1 door
Colonne 1 porte
Columna 1 puerta
Hochschrank 1 Tür

Apertura con gola verticale o maniglia
Opening with vertical groove or handle
Ouverture avec rainure verticale ou poignée
Apertura con uñero vertical o tirador
Öffnung mit vertikaler Griffleiste

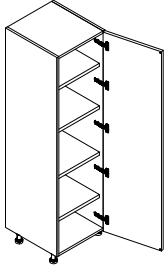

P/D	L/W	CODICE	0	1	2	3	4	5	6	7	8	9	10
34	30	KCN011950301	259	273	284	387	417	434	450	537	636	762	856
34	45	KCN011950451	285	304	345	438	475	496	547	656	813	975	1.076
34	60	KCN011950601	313	335	405	507	554	596	668	799	990	1.187	1.295
34	75	KCN011950751	381	403	473	575	622	663	736	867	1.060	1.257	1.521
57	30	KCN011950304	297	309	322	427	456	467	494	578	678	815	889
57	45	KCN011950454	329	345	390	478	515	536	590	699	863	1.038	1.116
57	60	KCN011950604	363	380	456	553	600	639	711	849	1.050	1.258	1.343
57	75	KCN011950754	431	448	524	621	668	707	779	917	1.120	1.328	1.575
67	30	KCN011950307	313	329	341	446	473	489	509	599	701	843	914
67	45	KCN011950457	346	365	407	499	534	554	608	717	886	1.063	1.145
67	60	KCN011950607	379	400	471	570	618	657	729	863	1.071	1.285	1.376
67	75	KCN011950757	447	468	539	638	686	725	797	931	1.141	1.355	1.613

Colonna 1 anta + 2 cestoni + 2 cassetti interni

Tall unit 1 door + 2 baskets + 2 internal drawers
Colonne 1 porte + 2 paniers + 2 tiroirs intérieurs
Columna 1 puerta + 2 cestas + 2 cajones interiores
Hochschrank 1 Tür + 2 Schubkasten + 2 Innenschubladen

Apertura con gola verticale o maniglia
Opening with vertical groove or handle
Ouverture avec rainure verticale ou poignée
Apertura con uñero vertical o tirador
Öffnung mit vertikaler Griffleiste

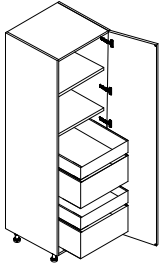

P/D	L/W	CODICE	0	1	2	3	4	5	6	7	8	9	10
57	45	KCK121950454	822	889	933	1.002	1.029	1.043	1.052	1.175	1.387	1.608	1.658
57	60	KCK121950604	918	1.005	1.086	1.168	1.224	1.236	1.272	1.378	1.647	1.919	1.969
57	75	KCK121950754	1.015	1.102	1.183	1.265	1.321	1.333	1.369	1.475	1.747	2.019	2.069
67	45	KCK121950457	927	995	1.044	1.115	1.137	1.146	1.158	1.282	1.520	1.767	1.817
67	60	KCK121950607	1.104	1.193	1.279	1.368	1.413	1.433	1.459	1.565	1.880	2.199	2.249
67	75	KCK121950757	1.201	1.290	1.376	1.465	1.510	1.530	1.556	1.662	1.980	2.299	2.349

Colonna 2 ante

Tall unit 2 doors
Colonne 2 portes
Columna 2 puertas
Hochschrank 2 Türen

Apertura solo con maniglia
Opening with handle only
Ouverture seulement avec la poignée
Apertura sólo con tirador
Öffnung nur mit Griff

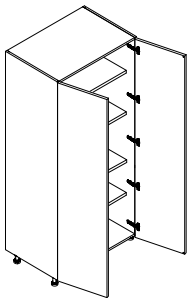

P/D	L/W	CODICE	0	1	2	3	4	5	6	7	8	9	10
34	90	KCN021950901	442	473	563	793	845	867	988	1.180	1.462	1.756	2.062
57	90	KCN021950904	495	528	612	845	896	919	997	1.261	1.559	1.873	2.123
67	90	KCN021950907	523	555	639	870	924	945	1.023	1.286	1.591	1.910	2.165

Basi con maniglia
Base units with handle

Basi con gola
Base units with groove

Colonne
Tall units

Pensili
Wall units

Elementi speciali
Special elements

Maniglie gole zoccoli
Handles grooves plinth

Illuminazione
Lighting

Accessori
Accessories

Componenti e meccanismi
Components e mechanism

COLONNE

Tall units
Colonnes
Columnas
Hochschranke

H. 195

Colonna 2 ante
Tall unit 2 doors
Colonne 2 portes
Columna 2 puertas
Hochschrank 2 Türen

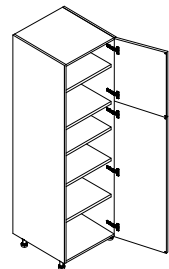

Apertura con gola verticale o maniglia
Opening with vertical groove or handle
Ouverture avec rainure verticale ou poignée
Apertura con uñero vertical o tirador
Öffnung mit vertikaler Griffleiste

P/D	L/W	CODICE	0	1	2	3	4	5	6	7	8	9	10
34	30	KCN041950301	263	319	348	391	425	463	495	590	726	872	922
34	45	KCN041950451	279	344	405	459	498	543	613	709	875	1.050	1.100
34	60	KCN041950601	310	373	463	538	588	654	745	883	1.089	1.308	1.324
34	75	KCN041950751	378	441	531	606	656	722	813	951	1.159	1.378	1.394
57	30	KCN041950304	312	347	379	420	452	493	524	621	763	916	956
57	45	KCN041950454	330	390	450	501	538	612	655	771	949	1.141	1.191
57	60	KCN041950604	345	423	502	579	627	692	784	921	1.138	1.365	1.376
57	75	KCN041950754	413	491	570	647	695	760	852	988	1.208	1.435	1.446
67	30	KCN041950307	331	367	399	438	469	509	538	638	786	944	994
67	45	KCN041950457	347	407	469	520	559	629	672	790	973	1.166	1.216
67	60	KCN041950607	365	441	521	596	644	709	801	940	1.159	1.391	1.412
67	75	KCN041950757	433	509	589	663	712	777	869	1.008	1.229	1.461	1.482

Colonna 4 ante
Tall unit 4-doors
Colonne 4 portes
Columna 4 puertas
4-türige Hochschrank

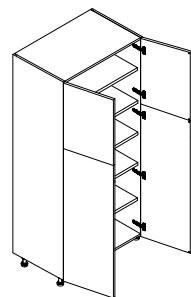

Apertura solo con maniglia
Opening with handle only
Ouverture seulement avec la poignée
Apertura sólo con tirador
Öffnung nur mit Griff

P/D	L/W	CODICE	0	1	2	3	4	5	6	7	8	9	10
34	90	KCN061950901	458	523	647	760	785	973	1.015	1.305	1.611	1.934	2.094
57	90	KCN061950904	509	585	706	817	843	1.032	1.073	1.395	1.722	2.066	2.163
67	90	KCN061950907	535	611	732	843	867	1.057	1.097	1.420	1.753	2.104	2.209

Colonna 2 ante
Tall unit 2 doors
Colonne 2 portes
Columna 2 puertas
Hochschrank 2 Türen

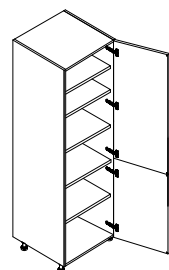

Apertura con gola verticale o maniglia
Opening with vertical groove or handle
Ouverture avec rainure verticale ou poignée
Apertura con uñero vertical o tirador
Öffnung mit vertikaler Griffleiste

P/D	L/W	CODICE	0	1	2	3	4	5	6	7	8	9	10
34	30	KCN031950301	263	319	348	391	425	463	495	590	726	872	922
34	45	KCN031950451	279	344	405	459	498	543	613	709	875	1.050	1.100
34	60	KCN031950601	310	373	463	538	588	654	745	883	1.089	1.308	1.324
34	75	KCN031950751	378	441	531	606	656	722	813	951	1.159	1.378	1.394
57	30	KCN031950304	312	347	379	420	452	493	524	621	763	916	956
57	45	KCN031950454	330	390	450	501	538	612	655	771	949	1.141	1.191
57	60	KCN031950604	345	423	502	579	627	692	784	921	1.138	1.365	1.376
57	75	KCN031950754	413	491	570	647	695	760	852	988	1.208	1.435	1.446
67	30	KCN031950307	331	367	399	438	469	509	538	638	786	944	994
67	45	KCN031950457	347	407	469	520	559	629	672	790	973	1.166	1.216
67	60	KCN031950607	365	441	521	596	644	709	801	940	1.159	1.391	1.412
67	75	KCN031950757	433	509	589	663	712	777	869	1.008	1.229	1.461	1.482

COLONNE

Tall units
Colonnes
Columnas
Hochschränke

H. 195

Colonna 4 ante

Tall unit 4-doors
Colonne 4 portes
Columna 4 puertas
4-türige Hochschrank

Apertura solo con maniglia

Opening with handle only
Ouverture seulement avec la poignée
Apertura sólo con tirador
Öffnung nur mit Griff

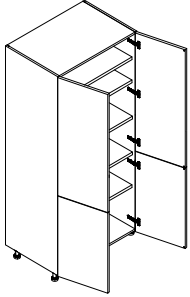

P/D	L/W	CODICE	0	1	2	3	4	5	6	7	8	9	10
34	90	KCN051950901	458	523	647	760	785	973	1.015	1.305	1.611	1.934	2.094
57	90	KCN051950904	509	585	706	817	843	1.032	1.073	1.395	1.722	2.066	2.163
67	90	KCN051950907	535	611	732	843	867	1.057	1.097	1.420	1.753	2.104	2.209

Colonna 2 ante + 2 cestoni + 2 cassetti interni

Tall unit 2 doors + 2 deep drawers
Colonne 2 portes + 2 paniers + 2 tiroirs intérieurs
Columna 2 puertas + 2 cajones interiores
Hochschrank 2 Türen + 2 Auszüge + 2 Schubkasten

Apertura con gola verticale o maniglia

Opening with vertical groove or handle
Ouverture avec rainure verticale ou poignée
Apertura con uñero vertical o tirador
Öffnung mit vertikaler Griffleiste

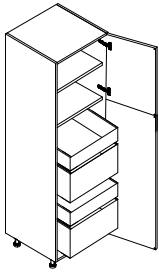

P/D	L/W	CODICE	0	1	2	3	4	5	6	7	8	9	10
57	45	KCK141950454	822	889	933	1.002	1.029	1.043	1.052	1.175	1.387	1.608	1.658
57	60	KCK141950604	918	1.005	1.086	1.168	1.224	1.236	1.272	1.378	1.647	1.919	1.969
57	75	KCK141950754	1.015	1.102	1.183	1.265	1.321	1.333	1.369	1.475	1.747	2.019	2.069
67	45	KCK141950457	927	995	1.044	1.115	1.137	1.146	1.158	1.282	1.520	1.767	1.817
67	60	KCK141950607	1.104	1.193	1.279	1.368	1.413	1.433	1.459	1.565	1.880	2.199	2.249
67	75	KCK141950757	1.201	1.290	1.376	1.465	1.510	1.530	1.556	1.662	1.980	2.299	2.349

Colonna 1 anta + 1 estraibile + 1 cestone interno

Tall unit 1 door + 1 pull-out + 1 inner basket
Colonne 1 porte + 1 extractible + 1 tiroir intérieur
Columna 1 puerta + 1 extraíble + 1 cajón interior
Hochschrank 1 Tür + 1 Auszug + 1 Innenschubkasten

Apertura con gola verticale o maniglia

Opening with vertical groove or handle
Ouverture avec rainure verticale ou poignée
Apertura con uñero vertical o tirador
Öffnung mit vertikaler Griffleiste

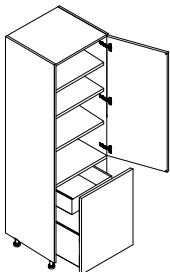

P/D	L/W	CODICE	0	1	2	3	4	5	6	7	8	9	10
57	45	KCN201950454	559	601	659	702	706	774	891	929	978	1.067	1.443
57	60	KCN201950604	626	669	747	790	824	891	1.077	1.102	1.140	1.286	1.704
57	75	KCN201950754	708	751	849	892	945	1.013	1.239	1.277	1.329	1.523	1.981
67	45	KCN201950457	604	647	704	748	752	820	950	975	1.025	1.114	1.490
67	60	KCN201950607	676	720	796	840	874	942	1.114	1.152	1.192	1.337	1.756
67	75	KCN201950757	762	806	904	948	1.000	1.068	1.293	1.332	1.375	1.580	2.038

Basi con maniglia
Base units with handle

Basi con gola
Base units with groove

Colonne
Tall units

Pensili
Wall units

Elementi speciali
Special elements

Maniglie gole zoccoli
Handles grooves plinth

Illuminazione
Lighting

Accessori
Accessories

Componenti e meccanismi
Components e mechanism

COLONNE

Tall units
Colonnes
Columnas
Hochschränke

H. 195

Colonna 1 anta + 4 cassetti

Tall unit 1 door + 4 drawers
Colonne 1 porte + 4 tiroirs
Columna 1 puerta + 4 cajones
Hochschrank 1 Tür + 4 Schubladen

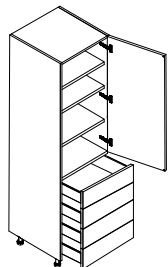

Apertura con gola verticale o maniglia
Opening with vertical groove or handle
Ouverture avec rainure verticale ou poignée
Apertura con uñero vertical o tirador
Öffnung mit vertikaler Griffleiste

P/D	L/W	CODICE	0	1	2	3	4	5	6	7	8	9	10
57	45	KCN241950454	614	658	749	792	831	899	991	1.059	1.231	1.379	1.707
57	60	KCN241950604	683	726	845	889	921	988	1.183	1.251	1.490	1.536	2.035
57	75	KCN241950754	755	797	944	987	1.016	1.083	1.383	1.451	1.675	1.695	2.367
67	45	KCN241950457	661	704	795	839	879	947	1.038	1.106	1.280	1.427	1.756
67	60	KCN241950607	736	779	898	941	973	1.041	1.236	1.304	1.545	1.590	2.090
67	75	KCN241950757	814	857	1.003	1.047	1.075	1.143	1.442	1.510	1.736	1.756	2.428

Colonna 1 anta + 2 cassetti + 1 cestone

Tall unit 1 door + 2 drawers + 1 basket
Colonne 1 porte + 2 tiroirs + 1 panier
Columna 1 puerta + 2 cajones + 1 cesta
Hochschrank 1 Tür + 2 Schubladen + 1 Schubkast

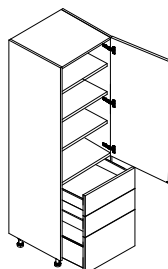

Apertura con gola verticale o maniglia
Opening with vertical groove or handle
Ouverture avec rainure verticale ou poignée
Apertura con uñero vertical o tirador
Öffnung mit vertikaler Griffleiste

P/D	L/W	CODICE	0	1	2	3	4	5	6	7	8	9	10
57	45	KCN231950454	566	610	690	733	749	817	913	981	1.153	1.211	1.589
57	60	KCN231950604	631	674	780	823	850	918	1.093	1.161	1.354	1.382	1.891
57	75	KCN231950754	700	743	874	917	954	1.021	1.281	1.349	1.502	1.572	2.198
67	45	KCN231950457	612	656	735	779	795	863	958	1.026	1.201	1.258	1.636
67	60	KCN231950607	682	726	830	874	900	968	1.145	1.213	1.407	1.435	1.944
67	75	KCN231950757	757	800	930	974	1.010	1.078	1.339	1.407	1.560	1.631	2.257

Colonna 1 anta + 2 cestoni

Tall unit 1 door + 2 baskets
Colonne 1 porte + 2 paniers
Columna 1 puerta + 2 cestas
Hochschrank 1 Tür + 2 Schubkasten

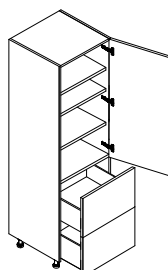

Apertura con gola verticale o maniglia
Opening with vertical groove or handle
Ouverture avec rainure verticale ou poignée
Apertura con uñero vertical o tirador
Öffnung mit vertikaler Griffleiste

P/D	L/W	CODICE	0	1	2	3	4	5	6	7	8	9	10
57	45	KCN221950454	519	563	631	674	666	734	834	902	1.043	1.075	1.471
57	60	KCN221950604	579	623	714	758	778	846	1.004	1.072	1.173	1.275	1.747
57	75	KCN221950754	646	689	803	847	891	959	1.180	1.248	1.309	1.469	2.030
67	45	KCN221950457	564	607	676	719	712	780	879	947	1.089	1.121	1.517
67	60	KCN221950607	629	672	763	807	827	895	1.053	1.121	1.224	1.326	1.798
67	75	KCN221950757	700	743	857	901	946	1.014	1.235	1.303	1.365	1.525	2.086

COLONNE

Tall units
Colonnes
Columns
Hochschränke

H. 195

Colonna 1 anta + 2 cestoni

Tall unit 1 door + 2 baskets
Colonne 1 porte + 2 paniers
Column 1 puerta + 2 cestas
Hochschrank 1 Tür + 2 Schubkasten

Apertura con gola orizzontale
Horizontal groove opening
Ouverture rainure horizontale
Apertura con uñero horizontal
Öffnung mit horizontaler Griffleiste

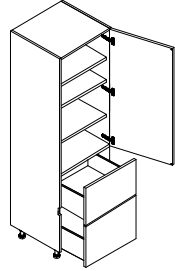

P/D	L/W	CODICE	0	1	2	3	4	5	6	7	8	9	10
57	45	KCG221950454	519	563	631	674	666	734	834	902	1.043	1.075	1.471
57	60	KCG221950604	579	623	714	758	778	846	1.004	1.072	1.173	1.275	1.747
57	75	KCG221950754	646	689	803	847	891	959	1.180	1.248	1.309	1.469	2.030
67	45	KCG221950457	564	607	676	719	712	780	879	947	1.089	1.121	1.517
67	60	KCG221950607	629	672	763	807	827	895	1.053	1.121	1.224	1.326	1.798
67	75	KCG221950757	700	743	857	901	946	1.014	1.235	1.303	1.365	1.525	2.086

Colonna 1 estraibile con meccanismo Linea Pro Sige

Tall unit 1 pull-out with mechanism Linea Pro Sige
Colonne 1 extractible avec mécanisme Linea Pro Sige
Column 1 extraíble con mecanismo Linea Pro Sige
Hochschrank 1 Auszug mit Mechanismus Linea Pro Sige

Apertura con gola verticale o maniglia
Opening with vertical groove or handle
Ouverture avec rainure verticale ou poignée
Apertura con uñero vertical o tirador
Öffnung mit vertikaler Griffleiste

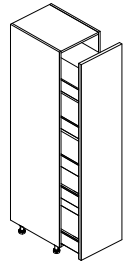

P/D	L/W	CODICE	0	1	2	3	4	5	6	7	8	9	10
57	30	KCN701950304	717	738	756	846	879	897	919	990	1.228	1.476	1.776
57	45	KCN701950454	791	803	821	940	962	990	1.008	1.157	1.432	1.720	2.020
67	30	KCN701950307	747	765	798	880	917	936	954	1.031	1.269	1.522	1.822
67	45	KCN701950457	821	836	855	977	1.000	1.028	1.046	1.201	1.480	1.776	2.076

Maggiorazione per meccanismo Linea Pure L. 30 Kessebohrer PUNTI 195

Mechanism Pure Line L. 30 Kessebohrer | Supplément pour le mécanisme Linea Pure L. 30 Kessebohrer | Recargo para mecanismo Linea Pure A.30 Kessebohrer | Aufpreis für Mechanismus Pure Line B. 30 Kessebohrer

Maggiorazione per meccanismo Linea Pure L. 45 Kessebohrer PUNTI 305

Mechanism Pure Line L. 45 Kessebohrer | Supplément pour le mécanisme Linea Pure L. 45 Kessebohrer | Recargo para mecanismo Linea Pure A.45 Kessebohrer | Aufpreis für Mechanismus Pure Line B. 45 Kessebohrer

Colonna 2 estraibili con meccanismo Linea Pro Sige

Tall unit 2 pull-outs with mechanism Linea Pro Sige
Colonne 2 extractibles avec mécanisme Linea Pro Sige
Column 2 extraíbles con mecanismo Linea Pro Sige
Hochschrank 2 Auszüge mit Mechanismus Linea Pro Sige

Apertura con gola verticale o maniglia
Opening with vertical groove or handle
Ouverture avec rainure verticale ou poignée
Apertura con uñero vertical o tirador
Öffnung mit vertikaler Griffleiste

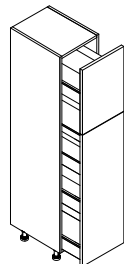

P/D	L/W	CODICE	0	1	2	3	4	5	6	7	8	9	10
57	30	KCN721950304	717	738	756	846	879	897	919	990	1.228	1.476	1.776
57	45	KCN721950454	791	803	821	940	962	990	1.008	1.157	1.432	1.720	2.020
67	30	KCN721950307	747	765	798	880	917	936	954	1.031	1.269	1.522	1.822
67	45	KCN721950457	821	836	855	977	1.000	1.028	1.046	1.201	1.480	1.776	2.076

Maggiorazione per meccanismo Linea Pure L. 30 Kessebohrer PUNTI 195

Mechanism Pure Line L. 30 Kessebohrer | Supplément pour le mécanisme Linea Pure L. 30 Kessebohrer | Recargo para mecanismo Linea Pure A.30 Kessebohrer | Aufpreis für Mechanismus Pure Line B. 30 Kessebohrer

Maggiorazione per meccanismo Linea Pure L. 45 Kessebohrer PUNTI 305

Mechanism Pure Line L. 45 Kessebohrer | Supplément pour le mécanisme Linea Pure L. 45 Kessebohrer | Recargo para mecanismo Linea Pure A.45 Kessebohrer | Aufpreis für Mechanismus Pure Line B. 45 Kessebohrer

Basi con maniglia
Base units with handle

Basi con gola
Base units with groove

Colonne
Tall units

Pensili
Wall units

Elementi speciali
Special elements

Maniglie gole zoccoli
Handles grooves plinth

Illuminazione
Lighting

Accessori
Accessories

Componenti e meccanismi
Components e mechanism

COLONNE

Tall units
Colonnes
Columnas
Hochschränke

H. 195

Colonna 2 estraibili con meccanismo Linea Pro Sige

Tall unit 2 pull-outs with mechanism Linea Pro Sige
Colonne 2 extractibles avec mécanisme Linea Pro Sige
Columna 2 extraíbles con mecanismo Linea Pro Sige
Hochschrank 2 Auszüge mit Mechanismus Linea Pro Sige

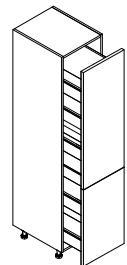

Apertura con gola verticale o maniglia
Opening with vertical groove or handle
Ouverture avec rainure verticale ou poignée
Apertura con uñero vertical o tirador
Öffnung mit vertikaler Griffleiste

P/D	L/W	CODICE	0	1	2	3	4	5	6	7	8	9	10
57	30	KCN711950304	717	738	756	846	879	897	919	990	1.228	1.476	1.776
57	45	KCN711950454	791	803	821	940	962	990	1.008	1.157	1.432	1.720	2.020
67	30	KCN711950307	747	765	798	880	917	936	954	1.031	1.269	1.522	1.822
67	45	KCN711950457	821	836	855	977	1.000	1.028	1.046	1.201	1.480	1.776	2.076

Maggiorazione per meccanismo Linea Pure L. 30 Kessebohmer PUNTI 195

Mechanism Pure Line L. 30 Kessebohmer | Supplément pour le mécanisme Linea Pure L. 30 Kessebohmer | Recargo para mecanismo Linea Pure A.30 Kessebohmer | Aufpreis für Mechanismus Pure Line B. 30 Kessebohmer

Maggiorazione per meccanismo Linea Pure L. 45 Kessebohmer PUNTI 305

Mechanism Pure Line L. 45 Kessebohmer | Supplément pour le mécanisme Linea Pure L. 45 Kessebohmer | Recargo para mecanismo Linea Pure A.45 Kessebohmer | Aufpreis für Mechanismus Pure Line B. 45 Kessebohmer

Colonna 1 anta con meccanismo Linea Pro Sige

Tall unit 1 door with mechanism Linea Pro Sige
Colonne 1 porte avec mécanisme Linea Pro Sige
Columna 1 puerta con mecanismo Linea Pro Sige
Hochschrank 1 Tür mit Mechanismus Linea Pro Sige

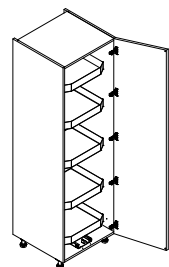

P/D	L/W	CODICE	0	1	2	3	4	5	6	7	8	9	10
57	60	KCN751950604	1.265	1.283	1.350	1.473	1.520	1.560	1.631	1.766	1.997	2.396	2.496
67	60	KCN751950607	1.280	1.302	1.370	1.492	1.537	1.577	1.649	1.786	2.021	2.425	2.525

Maggiorazione per meccanismo Arena Style Kessebohmer PUNTI 857

Arena Style Kessebohmer mechanism | Supplément pour le mécanisme Arena Style Kessebohmer | Recargo para mecanismo Arena Style Kessebohmer | Aufpreis für Arena Style Kessebohmer Mechanismus

Colonna 1 anta con meccanismo Linea Pro Sige

Tall unit 1 door with mechanism Linea Pro Sige
Colonne 1 porte avec mécanisme Linea Pro Sige
Columna 1 puerta con mecanismo Linea Pro Sige
Hochschrank 1 Tür mit Mechanismus Linea Pro Sige

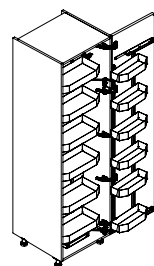

P/D	L/W	CODICE	0	1	2	3	4	5	6	7	8	9	10
57	45	KCN741950454	1.066	1.176	1.203	1.287	1.329	1.367	1.406	1.541	1.907	2.287	2.387
57	60	KCN741950604	1.137	1.256	1.277	1.407	1.441	1.470	1.598	1.740	2.154	2.585	2.685
67	45	KCN741950457	1.084	1.194	1.221	1.305	1.345	1.386	1.422	1.559	1.927	2.314	2.141
67	60	KCN741950607	1.153	1.273	1.296	1.424	1.460	1.486	1.617	1.759	2.178	2.613	2.713

Maggiorazione per meccanismo Linea Pure L. 45 Kessebohmer PUNTI 438

Mechanism Pure Line L. 45 Kessebohmer | Supplément pour le mécanisme Linea Pure L. 45 Kessebohmer | Recargo para mecanismo Linea Pure A.45 Kessebohmer | Aufpreis für Mechanismus Pure Line B. 45 Kessebohmer

Maggiorazione per meccanismo Linea Pure L. 60 Kessebohmer PUNTI 657

Mechanism Pure Line L. 60 Kessebohmer | Supplément pour le mécanisme Linea Pure L. 60 Kessebohmer | Recargo para mecanismo Linea Pure A.60 Kessebohmer | Aufpreis für Mechanismus Pure Line L. 60 Kessebohmer

COLONNE

Tall units
Colonnes
Columnas
Hochschränke

H. 195

Colonna 1 anta portascopio

Tall unit 1-door broom
Colonne 1 porte pour balai
Columna 1 puerta para escobas
Hochschrank 1 Tür Besenstiel

Apertura con gola verticale o maniglia
Opening with vertical groove or handle
Ouverture avec rainure verticale ou poignée
Apertura con uñero vertical o tirador
Öffnung mit vertikaler Griffleiste

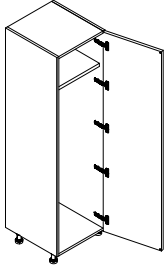

P/D	L/W	CODICE	0	1	2	3	4	5	6	7	8	9	10
57	45	KCN071950454	452	534	608	665	714	798	850	989	1.211	1.453	1.553
57	60	KCN071950604	543	643	736	824	880	959	1.067	1.237	1.515	1.819	1.919
67	45	KCN071950457	474	558	631	687	733	820	870	1.012	1.237	1.483	1.583
67	60	KCN071950607	554	666	760	845	902	981	1.091	1.258	1.541	1.848	1.948

Colonna 1 anta lavatrice - asciugatrice

Tall unit 1 door washer-dryer
Colonne 1 porte lave-linge-sèche-linge
Columna 1 puerta lavadora-secadora
Hochschrank 1 Tür Waschmaschine - Trockner

Apertura con gola verticale o maniglia
Opening with vertical groove or handle
Ouverture avec rainure verticale ou poignée
Apertura con uñero vertical o tirador
Öffnung mit vertikaler Griffleiste

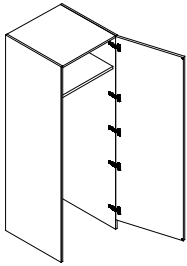

P/D	L/W	CODICE	0	1	2	3	4	5	6	7	8	9	10
67	69	KCN081950697	363	424	499	598	645	711	803	944	1.166	1.399	1.499

Colonna 2 ante lavatrice - asciugatrice

Tall unit 2 door washer-dryer
Colonne 2 portes lave-linge-sèche-linge
Columna 2 puertas lavadora-secadora
2-türige Waschmaschinen-Trockner-Hochschrank

Apertura solo con maniglia
Opening with handle only
Ouverture seulement avec la poignée
Apertura sólo con tirador
Öffnung nur mit Griff

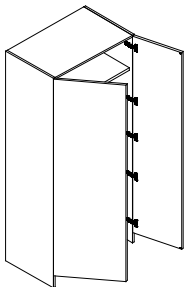

P/D	L/W	CODICE	0	1	2	3	4	5	6	7	8	9	10
67	90	KCN091950907	458	519	594	693	740	806	898	1.039	1.264	1.497	1.597

Basi con maniglia
Base units with handle

Basi con gola
Base units with groove

Colonne
Tall units

Pensili
Wall units

Elementi speciali
Special elements

Maniglie gole zoccoli
Handles grooves plinth

Illuminazione
Lighting

Accessori
Accessories

Componenti e meccanismi
Components e mechanism

COLONNE

Tall units
Colonnes
Columnas
Hochschränke

H. 195

Colonna angolo 1 anta
Corner tall unit 1 door
Colonne d'angle 1 porte
Columna ángulo 1 puerta
Eckehochschrank 1 Tür

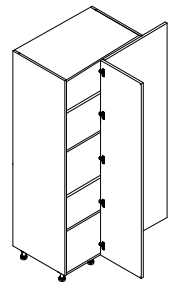

Apertura con gola verticale o maniglia
Opening with vertical groove or handle
Ouverture avec rainure verticale ou poignée
Apertura con uñero vertical o tirador
Öffnung mit vertikaler Griffleiste

P/D	L/W	CODICE	0	1	2	3	4	5	6	7	8	9	10
59,5	110	KCA011951104D/S	823	854	926	1.125	1.150	1.289	1.357	1.611	1.988	2.387	2.487
59,5	120	KCA011951204D/S	851	882	971	1.203	1.234	1.365	1.481	1.758	2.169	2.605	2.705
69,5	110	KCA011951107D/S	846	879	955	1.159	1.185	1.329	1.399	1.661	2.049	2.458	2.558
69,5	120	KCA011951207D/S	854	888	962	1.180	1.271	1.407	1.527	1.809	2.235	2.682	2.782

Colonna angolo 2 ante
Corner tall unit 2 doors
Colonne d'angle 2 portes
Columna ángulo 2 puertas
Eckehochschrank 2 Türen

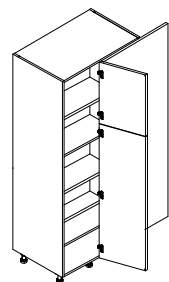

Apertura con gola verticale o maniglia
Opening with vertical groove or handle
Ouverture avec rainure verticale ou poignée
Apertura con uñero vertical o tirador
Öffnung mit vertikaler Griffleiste

P/D	L/W	CODICE	0	1	2	3	4	5	6	7	8	9	10
59,5	110	KCA041951104D/S	823	854	926	1.125	1.150	1.289	1.357	1.611	1.988	2.387	2.487
59,5	120	KCA041951204D/S	851	882	971	1.203	1.234	1.365	1.481	1.758	2.169	2.605	2.705
69,5	110	KCA041951107D/S	846	879	955	1.159	1.185	1.329	1.399	1.661	2.049	2.458	2.558
69,5	120	KCA041951207D/S	854	888	962	1.180	1.271	1.407	1.527	1.809	2.235	2.682	2.782

Colonna angolo 2 ante
Corner tall unit 2 doors
Colonne d'angle 2 portes
Columna ángulo 2 puertas
Eckehochschrank 2 Türen

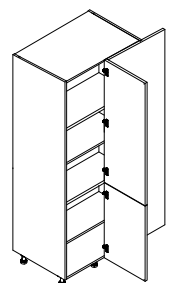

Apertura con gola verticale o maniglia
Opening with vertical groove or handle
Ouverture avec rainure verticale ou poignée
Apertura con uñero vertical o tirador
Öffnung mit vertikaler Griffleiste

P/D	L/W	CODICE	0	1	2	3	4	5	6	7	8	9	10
59,5	110	KCA031951104D/S	823	854	926	1.125	1.150	1.289	1.357	1.611	1.988	2.387	2.487
59,5	120	KCA031951204D/S	851	882	971	1.203	1.234	1.365	1.481	1.758	2.169	2.605	2.705
69,5	110	KCA031951107D/S	846	879	955	1.159	1.185	1.329	1.399	1.661	2.049	2.458	2.558
69,5	120	KCA031951207D/S	854	888	962	1.180	1.271	1.407	1.527	1.809	2.235	2.682	2.782

COLONNE

Tall units
Colonnes
Columns
Hochschränke

H. 195

Colonna angolo 1 ante con meccanismo Linea Pro Sige
Corner tall unit 1 door with mechanism Linea Pro Sige
Colonne d'angle 1 porte avec mécanisme Linea Pro Sige
Columna ángulo 1 puerta con mecanismo Linea Pro Sige
Eckehochschrank 1 Tür mit Mechanismus Linea Pro Sige

Apertura con gola verticale o maniglia
Opening with vertical groove or handle
Ouverture avec rainure verticale ou poignée
Apertura con uñero vertical o tirador
Öffnung mit vertikaler Griffleiste

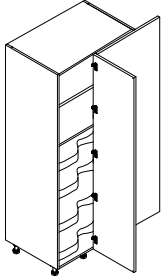

	P/D	L/W	CODICE	0	1	2	3	4	5	6	7	8	9	10
○	59,5	110	KCA761951104D/S	1.590	1.614	1.662	1.889	1.969	2.053	2.193	2.379	2.772	3.327	3.427
▲	59,5	125	KCA761951254D/S	1.597	1.627	1.697	1.887	1.965	2.106	2.175	2.429	2.835	3.403	3.503
○	69,5	120	KCA761951207D/S	1.727	1.756	1.828	2.067	2.155	2.260	2.429	2.632	3.063	3.677	3.777
▲	69,5	135	KCA761951357D/S	1.732	1.761	1.848	2.064	2.155	2.287	2.405	2.678	3.124	3.748	3.848

- **scocca da 90 cm** | 90 cm body | structure de 90 cm | estructura de 90 cm | 90 cm Korpus
- ▲ **scocca da 105 cm** | 105 cm body | structure de 105 cm | estructura de 105 cm | 105 cm Korpus

Maggiorazione per meccanismo Linea Pure Kessebohmer

Mechanism Pure Kessebohmer Line | Supplément pour le mécanisme Linea Pure Kessebohmer | Recargo para mecanismo Linea Pure Kessebohmer | Aufpreis für Mechanismus Pure Kessebohmer Line

Colonna angolo 2 ante con meccanismo Linea Pro Sige
Corner tall unit 2 doors with mechanism Linea Pro Sige
Colonne d'angle 2 portes avec mécanisme Linea Pro Sige
Columna ángulo 2 puertas con mecanismo Linea Pro Sige
2-türige Eckehochschrank mit Mechanismus Linea Pro Sige

Apertura con gola verticale o maniglia
Opening with vertical groove or handle
Ouverture avec rainure verticale ou poignée
Apertura con uñero vertical o tirador
Öffnung mit vertikaler Griffleiste

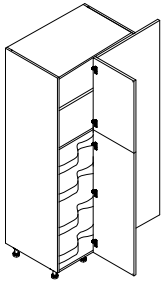

	P/D	L/W	CODICE	0	1	2	3	4	5	6	7	8	9	10
○	59,5	110	KCA781951104D/S	1.590	1.614	1.662	1.889	1.969	2.053	2.193	2.379	2.772	3.327	3.427
▲	59,5	125	KCA781951254D/S	1.597	1.627	1.697	1.887	1.965	2.106	2.175	2.429	2.835	3.403	3.503
○	69,5	120	KCA781951207D/S	1.727	1.756	1.828	2.067	2.155	2.260	2.429	2.632	3.063	3.677	3.777
▲	69,5	135	KCA781951357D/S	1.732	1.761	1.848	2.064	2.155	2.287	2.405	2.678	3.124	3.748	3.848

- **scocca da 90 cm** | 90 cm body | structure de 90 cm | estructura de 90 cm | 90 cm Korpus
- ▲ **scocca da 105 cm** | 105 cm body | structure de 105 cm | estructura de 105 cm | 105 cm Korpus

Maggiorazione per meccanismo Linea Pure Kessebohmer PUNTI 645

Mechanism Pure Kessebohmer Line | Supplément pour le mécanisme Linea Pure Kessebohmer | Recargo para mecanismo Linea Pure Kessebohmer | Aufpreis für Mechanismus Pure Kessebohmer Line

Colonna angolo 2 ante con meccanismo Linea Pro Sige
Corner tall unit 2 doors with mechanism Linea Pro Sige
Colonne d'angle 2 portes avec mécanisme Linea Pro Sige
Columna ángulo 2 puertas con mecanismo Linea Pro Sige
2-türige Eckehochschrank mit Mechanismus Linea Pro Sige

Apertura con gola verticale o maniglia
Opening with vertical groove or handle
Ouverture avec rainure verticale ou poignée
Apertura con uñero vertical o tirador
Öffnung mit vertikaler Griffleiste

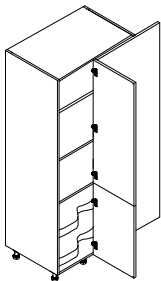

	P/D	L/W	CODICE	0	1	2	3	4	5	6	7	8	9	10
○	59,5	110	KCA771951104D/S	1.251	1.283	1.352	1.541	1.621	1.760	1.827	2.082	2.473	2.968	3.068
▲	59,5	125	KCA771951254D/S	1.287	1.318	1.388	1.583	1.664	1.806	1.876	2.137	2.542	3.049	3.149
○	69,5	120	KCA771951207D/S	1.342	1.372	1.455	1.675	1.764	1.895	2.013	2.288	2.717	3.260	3.360
▲	69,5	135	KCA771951357D/S	1.377	1.407	1.493	1.715	1.807	1.944	2.062	2.344	2.786	3.343	3.443

- **scocca da 90 cm** | 90 cm body | structure de 90 cm | estructura de 90 cm | 90 cm Korpus
- ▲ **scocca da 105 cm** | 105 cm body | structure de 105 cm | estructura de 105 cm | 105 cm Korpus

Maggiorazione per meccanismo Linea Pure Kessebohmer PUNTI 269

Mechanism Pure Kessebohmer Line | Supplément pour le mécanisme Linea Pure Kessebohmer | Recargo para mecanismo Linea Pure Kessebohmer | Aufpreis für Mechanismus Pure Kessebohmer Line

Basi con maniglia
Base units with handle

Basi con gola
Base units with groove

Colonne
Tall units

Pensili
Wall units

Elementi speciali
Special elements

Maniglie gole zoccoli
Handles grooves plinth

Illuminazione
Lighting

Accessori
Accessories

Componenti e meccanismi
Components e mechanism

COLONNE

Tall units
Colonnes
Columnas
Hochschränke

H. 195

Colonna 1 anta copriboiler

Tall unit 1 door for water header / boiler
Colonne 1 porte pour cumulus
Columna 1 puerta para cubrir un boiler
Abdeckung der Wasser-warme

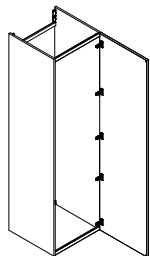

Apertura con gola verticale o maniglia
Opening with vertical groove or handle
Ouverture avec rainure verticale ou poignée
Apertura con uñero vertical o tirador
Öffnung mit vertikaler Griffleiste

P/D	L/W	CODICE	0	1	2	3	4	5	6	7	8	9	10
57	60	KCD011950604	266	294	333	396	405	451	499	593	723	897	947
67	60	KCD011950607	277	306	344	407	417	463	510	604	735	909	959

COLONNE FORNO

H. 195

Oven tall units
Colonnes four
Columnas horno
Backofen-Hochschranke

Colonna forno 2 ante (frontale superiore su misura)

Oven tall unit 2 doors (upper front made to measure)
Colonne four 2 portes (façade supérieure sur mesure)
Columna horno 2 puertas (frontal superior a medida)
Backofenschrank 2 Türen (obere Front nach Maß)

Apertura con gola verticale o maniglia
Opening with vertical groove or handle
Ouverture avec rainure verticale ou poignée
Apertura con uñero vertical o tirador
Öffnung mit vertikaler Griffleiste

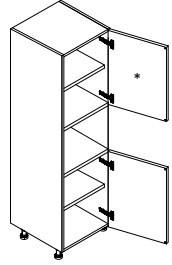

P/D	L/W	CODICE	0	1	2	3	4	5	6	7	8	9	10
57	60	KCP021950604	393	463	484	567	606	655	708	824	1.003	1.204	1.224
67	60	KCP021950607	412	482	502	586	623	673	726	843	1.025	1.229	1.257

* Frontale su misura | Customised front panel | Façade sur mesure | Frente medida especial | Fronten in Sondermasse

Colonna forno 2 ante

Oven tall unit 2 doors
Colonne four 2 portes
Columna horno 2 puertas
Backofenschrank 2 Türen

Apertura con gola verticale o maniglia
Opening with vertical groove or handle
Ouverture avec rainure verticale ou poignée
Apertura con uñero vertical o tirador
Öffnung mit vertikaler Griffleiste

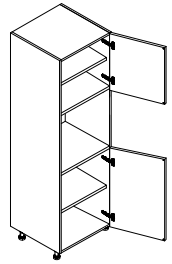

P/D	L/W	CODICE	0	1	2	3	4	5	6	7	8	9	10
57	60	KC0021950604	309	361	406	489	528	576	630	743	921	1.106	1.224
57	75	KC0021950754	329	378	424	506	543	595	646	762	944	1.132	1.257
67	60	KC0021950607	377	429	474	557	596	644	697	811	991	1.176	1.294
67	75	KC0021950757	397	446	492	574	611	663	714	830	1.014	1.202	1.327

□ forno L 75 cm | oven L 75 cm | four L 75 cm | horno L 75 cm | backofen B 75 cm

Colonna forno 1 anta + 1 estraibile + 1 cestone interno

Oven tall unit 1 door + 1 drawer + 1 inner basket
Colonne four 1 porte + 1 extractible + 1 tiroir intérieur
Columna horno 1 puerta + 1 cajón + 1 cajón interior
Backofenschrank 1 Tür + 1 Schublade + 1 Innenschubkast

Apertura con gola verticale o maniglia
Opening with vertical groove or handle
Ouverture avec rainure verticale ou poignée
Apertura con uñero vertical o tirador
Öffnung mit vertikaler Griffleiste

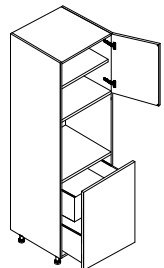

P/D	L/W	CODICE	0	1	2	3	4	5	6	7	8	9	10
57	60	KC0201950604	501	587	629	722	766	815	852	997	1.223	1.468	1.568
57	75	KC0201950754	599	686	728	821	865	913	949	1.096	1.347	1.617	1.717
67	60	KC0201950607	568	655	696	790	834	883	920	1.065	1.293	1.538	1.638
67	75	KC0201950757	667	754	796	889	933	981	1.017	1.164	1.417	1.687	1.787

□ forno L 75 cm | oven L 75 cm | four L 75 cm | horno L 75 cm | backofen B 75 cm

Basi con maniglia
Base units with handle

Basi con gola
Base units with groove

Colonne
Tall units

Pensili
Wall units

Elementi speciali
Special elements

Maniglie gole zoccoli
Handles grooves plinth

Illuminazione
Lighting

Accessori
Accessories

Componenti e meccanismi
Components e mechanism

COLONNE FORNO

Oven tall units
Colonnes four
Columnas horno
Backofen-Hochschränke

H. 195

Colonna forno 1 anta + 1 estraibile + 2 cassetti interni

Oven tall unit 1 door + 1 pull-out + 2 internal drawers
Colonne four 1 porte + 1 extractible + 2 tiroirs intérieurs
Columna horno 1 puerta + 1 extraíble + 2 cajones interiores
Backofenschrank 1 Tür + 1 Auszug + 2 Innenschubladen

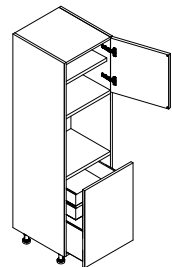

Apertura con gola verticale o maniglia
Opening with vertical groove or handle
Ouverture avec rainure verticale ou poignée
Apertura con uñero vertical o tirador
Öffnung mit vertikaler Griffleiste

P/D	L/W	CODICE	0	1	2	3	4	5	6	7	8	9	10
57	60	KC0211950604	568	655	696	790	834	883	920	1.065	1.293	1.538	1.638
57	75	KC0211950754	667	754	796	889	933	981	1.017	1.164	1.417	1.687	1.787
67	60	KC0211950607	636	723	764	857	902	951	987	1.133	1.363	1.608	1.708
67	75	KC0211950757	735	822	864	956	1.001	1.049	1.084	1.232	1.487	1.757	1.857

□ **forno L 75 cm** | oven L 75 cm | four L 75 cm | horno L 75 cm | backofen B 75 cm

Colonna forno 1 anta + 4 cassetti

Oven tall unit 1 door + 4 drawers
Colonne four 1 porte + 4 tiroirs
Columna horno 1 puerta + 4 cajones
Backofenschrank 1 Tür + 4 Schubladen

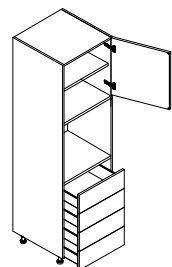

Apertura con gola verticale o maniglia
Opening with vertical groove or handle
Ouverture avec rainure verticale ou poignée
Apertura con uñero vertical o tirador
Öffnung mit vertikaler Griffleiste

P/D	L/W	CODICE	0	1	2	3	4	5	6	7	8	9	10
57	60	KC0241950604	595	695	737	851	902	929	1.019	1.141	1.410	1.694	1.716
57	75	KC0241950754	663	762	805	919	970	997	1.086	1.209	1.480	1.764	1.786
67	60	KC0241950607	763	862	909	1.020	1.073	1.099	1.186	1.310	1.621	1.946	2.046
67	75	KC0241950757	831	930	977	1.088	1.141	1.167	1.254	1.377	1.691	2.016	2.116

□ **forno L 75 cm** | oven L 75 cm | four L 75 cm | horno L 75 cm | backofen B 75 cm

Colonna forno 1 anta + 2 cassetti + 1 cestone

Oven tall unit 1 door + 2 drawers + 1 drawer
Colonne four 1 porte + 2 tiroirs + 1 tiroir
Columna horno 1 puerta + 2 cajones + 1 cajón
Backofenschrank 1 Tür + 2 Schubladen + 1 Schublade

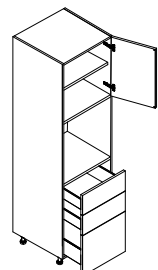

Apertura con gola verticale o maniglia
Opening with vertical groove or handle
Ouverture avec rainure verticale ou poignée
Apertura con uñero vertical o tirador
Öffnung mit vertikaler Griffleiste

P/D	L/W	CODICE	0	1	2	3	4	5	6	7	8	9	10
57	60	KC0231950604	546	639	684	786	835	874	925	1.067	1.317	1.581	1.681
57	75	KC0231950754	614	707	752	854	903	942	993	1.135	1.387	1.651	1.751
67	60	KC0231950607	682	774	819	920	970	1.008	1.061	1.203	1.484	1.782	1.882
67	75	KC0231950757	750	842	887	987	1.038	1.076	1.129	1.271	1.554	1.852	1.952

□ **forno L 75 cm** | oven L 75 cm | four L 75 cm | horno L 75 cm | backofen B 75 cm

COLONNE FORNO

H. 195

Oven tall units
Colonnes four
Columnas horno
Backofen-Hochschranke

Colonna forno 1 anta + 2 cestoni

Oven tall unit 1 door + 2 baskets
Colonne four 1 porte + 2 paniers
Columna horno 1 puerta + 2 cestas
Backofenschrank 1 Tür + 2 Schubkasten

Apertura con gola verticale o maniglia
Opening with vertical groove or handle
Ouverture avec rainure verticale ou poignée
Apertura con uñero vertical o tirador
Öffnung mit vertikaler Griffleiste

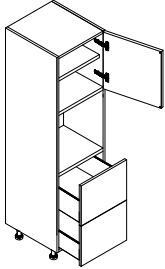

	P/D	L/W	CODICE	0	1	2	3	4	5	6	7	8	9	10
	57	60	KC0221950604	501	587	629	722	766	815	852	997	1.223	1.468	1.568
□	57	75	KC0221950754	568	655	696	790	834	883	920	1.065	1.293	1.538	1.638
	67	60	KC0221950607	599	686	728	821	865	913	949	1.096	1.347	1.617	1.717
□	67	75	KC0221950757	667	754	796	889	933	981	1.017	1.164	1.417	1.687	1.787

□ forno L 75 cm | oven L 75 cm | four L 75 cm | horno L 75 cm | backofen B 75 cm

Colonna forno 1 anta + 2 cestoni

Oven tall unit 1 door + 2 baskets
Colonne four 1 porte + 2 paniers
Columna horno 1 puerta + 2 cestas
Backofenschrank 1 Tür + 2 Schubkasten

Apertura con gola orizzontale
Horizontal groove opening
Ouverture rainure horizontale
Apertura con uñero horizontal
Öffnung mit horizontaler Griffleiste

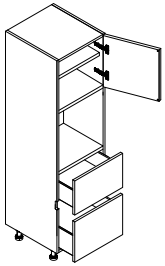

	P/D	L/W	CODICE	0	1	2	3	4	5	6	7	8	9	10
	57	60	KCH221950604	501	587	629	722	766	815	852	997	1.223	1.468	1.568
□	57	75	KCH221950754	568	655	696	790	834	883	920	1.065	1.293	1.538	1.638
	67	60	KCH221950607	599	686	728	821	865	913	949	1.096	1.347	1.617	1.717
□	67	75	KCH221950757	667	754	796	889	933	981	1.017	1.164	1.417	1.687	1.787

□ forno L 75 cm | oven L 75 cm | four L 75 cm | horno L 75 cm | backofen B 75 cm

Colonna forno + microonde 1 vasistas + 1 cestone

Oven Tall unit + microwave 1 vasistas + 1 drawer
Colonne four + micro 1 vasistas + 1 panier
Horno columna + microondas 1 cajón
Backofen + Mikrowelle Schrank 1 Klapptur + 1 Schublade

Apertura con gola verticale o maniglia
Opening with vertical groove or handle
Ouverture avec rainure verticale ou poignée
Apertura con uñero vertical o tirador
Öffnung mit vertikaler Griffleiste

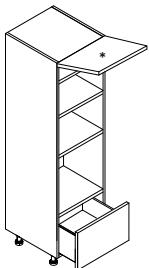

	P/D	L/W	CODICE	0	1	2	3	4	5	6	7	8	9	10
	57	60	KCM451950604	442	528	574	670	722	780	834	991	1.227	1.473	1.573
	67	60	KCM451950607	501	585	631	727	780	835	892	1.050	1.285	1.544	1.644

* Frontale su misura | Customised front panel | Façade sur mesure | Frente medida especial | Fronten in Sondermasse

Basi con maniglia
Base units with handle

Basi con gola
Base units with groove

Colonne
Tall units

Pensili
Wall units

Elementi speciali
Special elements

Maniglie gole zoccoli
Handles grooves plinth

Illuminazione
Lighting

Accessori
Accessories

Componenti e meccanismi
Components e mechanism

COLONNE FORNO

Oven tall units
Colonnes four
Columnas horno
Backofen-Hochschränke

H. 195

Colonna forno + cantinetta 1 anta + 1 frontale fisso

Tall unit oven + wine cellar 1 door + 1 fixed front
Colonne four + cave à vin 1 porte + 1 façade fixe
Columna para horno+ espacio para vinos + 1 frente fijo
Schrankofen + Weinkeller 1 Tür + 1 feste Front

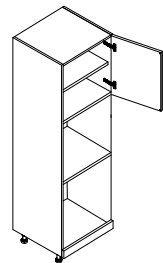

Apertura con gola verticale o maniglia
Opening with vertical groove or handle
Ouverture avec rainure verticale ou poignée
Apertura con uñero vertical o tirador
Öffnung mit vertikaler Griffleiste

P/D	L/W	CODICE	0	1	2	3	4	5	6	7	8	9	10
57	60	KCQ311950604	302	35	388	463	495	537	584	687	846	1.016	1.116
67	60	KCQ311950607	321	367	405	480	510	557	600	705	869	1.042	1.142

Colonna forno + microonde 1 vasistas + 1 anta

Oven tall unit + microwave 1 vasistas + 1 door
Colonne four + micro 1 vasistas + 1 porte
Columna horno + microondas 1 vasistas + 1 puerta
Schrankofen + Mikrowelle 1 Klapptür + 1 Tür

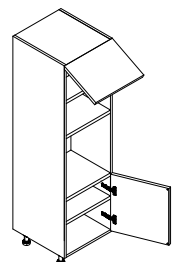

Apertura con gola verticale o maniglia
Opening with vertical groove or handle
Ouverture avec rainure verticale ou poignée
Apertura con uñero vertical o tirador
Öffnung mit vertikaler Griffleiste

P/D	L/W	CODICE	0	1	2	3	4	5	6	7	8	9	10
57	60	KCM421950604	328	396	443	532	544	594	611	647	778	939	1.039
67	60	KCM421950607	346	414	463	549	563	595	629	649	789	950	1.050

Colonna forno + microonde 1 vasistas + 1 cassetto + 1 cestone

Oven tall unit + microwave 1 vasistas + 1 drawer + 1 drawer
Colonne four + micro 1 vasistas + 1 tiroir + 1 panier
Columna horno + microondas 1 vasistas + 1 cajón + 1 cajón
Schrankofen + Mikrowelle 1 vasistas + 1 Schublade + 1 Schublade

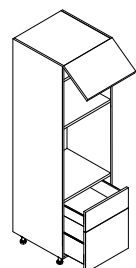

Apertura con gola verticale o maniglia
Opening with vertical groove or handle
Ouverture avec rainure verticale ou poignée
Apertura con uñero vertical o tirador
Öffnung mit vertikaler Griffleiste

P/D	L/W	CODICE	0	1	2	3	4	5	6	7	8	9	10
57	60	KCM441950604	510	594	638	729	773	824	858	1.005	1.237	1.484	1.584
67	60	KCM441950607	606	690	734	825	868	920	954	1.100	354	1.624	1.724

COLONNE FORNO

Oven tall units
Colonnes four
Columnas horno
Backofen-Hochschränke

H. 195

Colonna forno + microonde 1 vasistas + 1 cassetto + 1 cestone

Oven tall unit + microwave 1 vasistas + 1 drawer + 1 drawer
Colonne four + micro 1 vasistas + 1 tiroir + 1 panier
Columna horno + microondas 1 vasistas + 1 cajón + 1 cajón
Schrankofen + Mikrowelle 1 vasistas + 1 Schublade + 1 Schublade

Apertura con gola orizzontale
Horizontal groove opening
Ouverture rainure horizontale
Apertura con uñero horizontal
Öffnung mit horizontaler Griffleiste

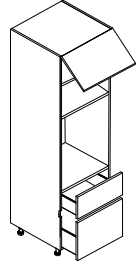

P/D	L/W	CODICE	0	1	2	3	4	5	6	7	8	9	10
57	60	KCI441950604	510	594	638	729	773	824	858	1.005	1.237	1.484	1.584
67	60	KCI441950607	606	690	734	825	868	920	954	1.100	354	1.624	1.724

Colonna forno sospesa 1 anta (sopra lavastoviglie)

Suspended oven tall unit 1 door (above dishwasher)
Colonne four suspendue 1 porte (au-dessus du lave-vaisselle)
Columna horno suspendida 1 puerta (sobre lavavajillas)
Haenge Backofenschrank 1 Tür (über Geschirrspüler)

Apertura con gola verticale o maniglia
Opening with vertical groove or handle
Ouverture avec rainure verticale ou poignée
Apertura con uñero vertical o tirador
Öffnung mit vertikaler Griffleiste

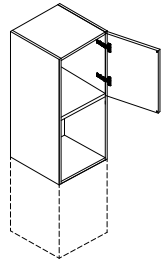

P/D	L/W	CODICE	0	1	2	3	4	5	6	7	8	9	10
57	60	KCS011170604	280	344	372	420	441	471	499	566	693	823	923
67	60	KCS011170607	289	353	381	433	457	485	514	292	712	848	948

Colonna forno 2 ante + 2 cestoni

Oven tall unit 2 doors + 2 baskets
Colonne four 2 portes + 2 paniers
Columna horno 2 puertas + 2 cestas
Backofenschrank 2 Türen + 2 Schubkasten

Apertura solo con maniglia
Opening with handle only
Ouverture seulement avec la poignée
Apertura sólo con tirador
Öffnung nur mit Griff

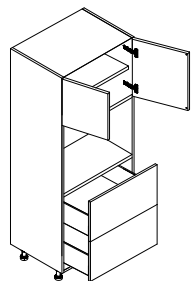

P/D	L/W	CODICE	0	1	2	3	4	5	6	7	8	9	10
57	90	KCO261950904	663	758	793	893	978	1.086	1.229	1.314	1.655	2.027	2.127
67	90	KCO261950907	731	825	861	961	1.046	1.154	1.297	1.382	1.725	2.097	2.197

Basi con maniglia
Base units with handle

Basi con gola
Base units with groove

Colonne
Tall units

Pensili
Wall units

Elementi speciali
Special elements

Maniglie gole zoccoli
Handles grooves plinth

Illuminazione
Lighting

Accessori
Accessories

Componenti e meccanismi
Components e mechanism

COLONNE FORNO

Oven tall units
Colonnes four
Columnas horno
Backofen-Hochschränke

H. 195

Colonna forno H. 48 4 ante

Oven tall unit H 48 4 doors
Colonne four H 48 4 portes
Columna horno H 48 4 puertas
Backofenschrank H 48 4 Türen

Apertura solo con maniglia
Opening with handle only
Ouverture seulement avec la poignée
Apertura sólo con tirador
Öffnung nur mit Griff

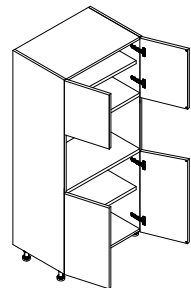

P/D	L/W	CODICE	0	1	2	3	4	5	6	7	8	9	10
57	90	KCP051950904	596	690	726	825	910	1.019	1.161	1.246	1.585	1.957	2.057
67	90	KCP051950907	663	758	793	893	978	1.086	1.229	1.314	1.655	2.027	2.127

Colonna forno H. 48 2 ante + 2 cestoni

Oven tall unit H 48 2 doors + 2 baskets
Colonne four H 48 2 portes + 2 paniers
Columna horno H 48 2 puertas + 2 cestas
Backofenschrank H 48 2 Türen + 2 Schubkasten

Apertura con gola orizzontale
Horizontal groove opening
Ouverture rainure horizontale
Apertura con uñero horizontal
Öffnung mit horizontaler Griffleiste

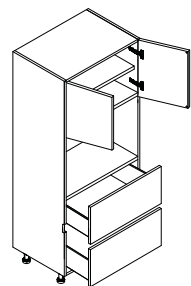

P/D	L/W	CODICE	0	1	2	3	4	5	6	7	8	9	10
57	90	KCJ261950904	663	758	793	893	978	1.086	1.229	1.314	1.655	2.027	2.127
67	90	KCJ261950907	731	825	861	961	1.046	1.154	1.297	1.382	1.725	2.097	2.197

Colonna angolo forno 2 ante

Corner tall unit for oven 2 doors
Colonne four d'angle 2 portes
Columna ángulo 2 puertas para horno
Backofen Ecke-Hochschrank 2 Türen

Apertura con gola verticale o maniglia
Opening with vertical groove or handle
Ouverture avec rainure verticale ou poignée
Apertura con uñero vertical o tirador
Öffnung mit vertikaler Griffleiste

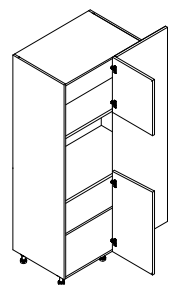

	P/D	L/W	CODICE	0	1	2	3	4	5	6	7	8	9	10
○	59,5	125	KCC021951254D/S	802	820	863	1.054	1.132	1.272	1.340	1.594	1.971	2.365	2.465
▲	69,5	135	KCC021951357D/S	824	839	884	1.072	1.151	1.289	1.357	1.612	1.990	2.388	2.488

- **scocca da 90 cm** | 90 cm body | structure de 90 cm | estructura de 90 cm | 90 cm Korpus
▲ **scocca da 105 cm** | 105 cm body | structure de 105 cm | estructura de 105 cm | 105 cm Korpus

COLONNE FRIGO

Fridge tall units
Colonnes frigo
Columnas nevera
Kühlschrank Hochschränke

H. 195

Colonna frigo H. 122,5 2 ante

Refrigerator tall unit H 122,5 2 doors
Colonne frigo H 122,5 2 portes
Columna nevera H 122,5 2 puertas
Kühlschrank Hochschrank H 122,5 2 Türen

Apertura con gola verticale o maniglia
Opening with vertical groove or handle
Ouverture avec rainure verticale ou poignée
Apertura con uñero vertical o tirador
Öffnung mit vertikaler Griffleiste

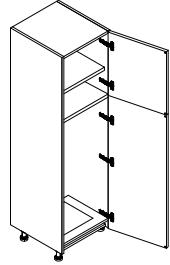

P/D	L/W	CODICE	0	1	2	3	4	5	6	7	8	9	10
57	60	KCF041950604	364	427	503	579	628	695	788	924	1.144	1.373	1.393
67	60	KCF041950607	380	444	524	598	645	711	803	944	1.166	1.399	1.419

Maggiorazione per apertura elettrica anta singola PUNTI 467

Surcharge for electric single door opening | Supplément pour ouverture électrique d'une porte seule | Recargo para apertura eléctrica puerta singular | Aufpreis für elektrische Türöffnung

Colonna frigo H. 178 1 anta

Refrigerator tall unit H 178 1 door
Colonne frigo H 178 1 porte
Columna nevera H 178 1 puerta
Kühlschrank Hochschrank H 178 1 Tür

Apertura con gola verticale o maniglia
Opening with vertical groove or handle
Ouverture avec rainure verticale ou poignée
Apertura con uñero vertical o tirador
Öffnung mit vertikaler Griffleiste

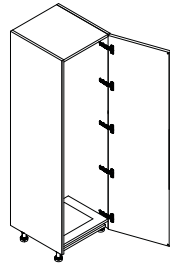

P/D	L/W	CODICE	0	1	2	3	4	5	6	7	8	9	10
57	60	KCF011950604	364	427	503	579	628	695	788	924	1.144	1.373	1.393
67	60	KCF011950607	380	444	524	598	645	711	803	944	1.166	1.399	1.419

Maggiorazione per apertura elettrica anta singola PUNTI 467

Surcharge for electric single door opening | Supplément pour ouverture électrique d'une porte seule | Recargo para apertura eléctrica puerta singular | Aufpreis für elektrische Türöffnung

Colonna frigo H. 178 2 ante

Refrigerator tall unit H 178 2 doors
Colonne frigo H 178 2 portes
Columna nevera H 178 2 puertas
Kühlschrank Hochschrank H 178 2 Türen

Apertura con gola verticale o maniglia
Opening with vertical groove or handle
Ouverture avec rainure verticale ou poignée
Apertura con uñero vertical o tirador
Öffnung mit vertikaler Griffleiste

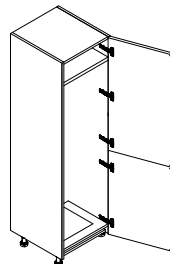

P/D	L/W	CODICE	0	1	2	3	4	5	6	7	8	9	10
57	60	KCF031950604	364	427	503	579	628	695	788	924	1.144	1.373	1.393
67	60	KCF031950607	380	444	524	598	645	711	803	944	1.166	1.399	1.419

Maggiorazione per apertura elettrica anta doppia PUNTI 934

Surcharge for electric double sash opening | Supplément pour l'ouverture électrique d'une porte double | Recargo para apertura eléctrica puerta doble | Aufpreis für elektrische Doppeltüröffnung

Basi con maniglia
Base units with handle

Basi con gola
Base units with groove

Colonne
Tall units

Pensili
Wall units

Elementi speciali
Special elements

Maniglie gole zoccoli
Handles grooves plinth

Illuminazione
Lighting

Accessori
Accessories

Componenti e meccanismi
Components e mechanism

COLONNE VETRINA

H. 195

Showcase tall units
Vitrine
Columnas vitrina
Glasstuer Hochschranke

Colonna vetrina 1 ante

Display tall unit 1 door
Vitrine 1 porte
Columna vitrina 1 puerta
Vitrinensäule 1 Tür

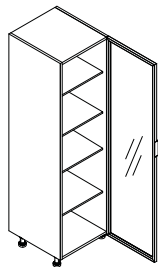

P/D	L/W	CODICE	0	1	2	3	4	5	6	7	8	9	10
34	45	KCV011950451	673	724	909	1.239	-	-	-	-	-	-	-
34	60	KCV011950601	771	829	1.041	1.419	-	-	-	-	-	-	-
57	45	KCV011950454	728	783	983	1.339	-	-	-	-	-	-	-
57	60	KCV011950604	852	916	1.150	1.568	-	-	-	-	-	-	-
67	45	KCV011950457	750	806	1.012	1.379	-	-	-	-	-	-	-
67	60	KCV011950607	875	941	1.182	1.610	-	-	-	-	-	-	-

Colonna vetrina 2 ante

Display tall unit 2 doors
Vitrine 2 portes
Columna vitrina 2 puertas
Hochschrank 2 Glasstüren

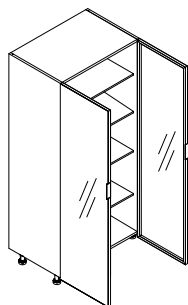

P/D	L/W	CODICE	0	1	2	3	4	5	6	7	8	9	10
34	90	KCV021950901	1.297	1.394	1.751	2.386	-	-	-	-	-	-	-
57	90	KCV021950904	1.327	1.426	1.791	2.441	-	-	-	-	-	-	-
67	90	KCV021950907	1.352	1.454	1.826	2.489	-	-	-	-	-	-	-

COLONNE USA

USA tall units
Colonnes américaines
Columnas USA
US-Hochschränke

H. 195

Colonna USA (30") forno + microonde 1 vasistas + 1 cestone

USA tall units (30") oven + microwave 1 drawer
Colonne USA (30") four + micro +1 vasistas+ 1 panier
Columna US (30") horno + microondas 1 cajón
US-Hochschrank (30") Backofen + Mikrowelle 1 Schublade

Apertura con gola verticale o maniglia
Opening with vertical groove or handle
Ouverture avec rainure verticale ou poignée
Apertura con uñero vertical o tirador
Öffnung mit vertikaler Griffleiste

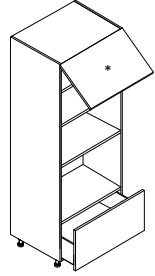

P/D	L/W	CODICE	0	1	2	3	4	5	6	7	8	9	10
57	76,2	KCM451950764	633	740	779	922	1.046	1.163	1.348	1.571	2.001	2.308	2.408
67	76,2	KCM451950767	701	808	847	989	1.114	1.231	1.416	1.639	2.071	2.378	2.478

* Frontale su misura | Customised front panel | Façade sur mesure | Frente medida especial | Fronten in Sondermasse

Colonna USA (30") forno 1 vasistas + 2 cestoni

USA tall unit (30") oven 1 vasistas + 2 baskets
Colonne USA (30") four 1 vasistas + 2 paniers
Columna USA (30") horno 1 vasistas + 2 cestas
USA Hochschrank (30") Ofen 1 vasistas + 2 Schubkasten

Apertura con gola verticale o maniglia
Opening with vertical groove or handle
Ouverture avec rainure verticale ou poignée
Apertura con uñero vertical o tirador
Öffnung mit vertikaler Griffleiste

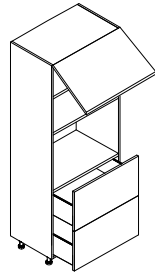

P/D	L/W	CODICE	0	1	2	3	4	5	6	7	8	9	10
57	76,2	KCO481950764	823	930	975	1.046	1.220	1.407	1.542	1.763	2.171	2.651	2.741
67	76,2	KCO481950767	890	998	1.043	1.114	1.288	1.474	1.610	1.831	2.241	2.721	2.811

Colonna USA (30") forno 2 ante + 2 cestoni

USA tall unit (30") oven 2 doors + 2 baskets
Colonne USA C (30") four 2 portes + 2 paniers
Columna USA (30") horno 2 puertas + 2 cestas
USA Hochschrank (30") 2 Türen + 2 Schubkasten

Apertura con gola orizzontale
Horizontal groove opening
Ouverture rainure horizontale
Apertura con uñero horizontal
Öffnung mit horizontaler Griffleiste

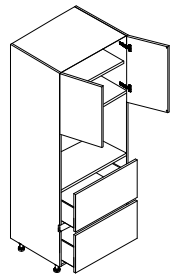

P/D	L/W	CODICE	0	1	2	3	4	5	6	7	8	9	10
57	76,2	KCH261950764	755	862	907	978	1.152	1.339	1.474	1.696	2.101	2.581	2.671
67	76,2	KCH261950767	823	930	975	1.046	1.220	1.407	1.542	1.763	2.171	2.651	2.741

Basi con maniglia
Base units with handle

Basi con gola
Base units with groove

Colonne
Tall units

Pensili
Wall units

Elementi speciali
Special elements

Maniglie gole zoccoli
Handles grooves plinth

Illuminazione
Lighting

Accessori
Accessories

Componenti e meccanismi
Components e mechanism

COLONNE

Tall units
Colonnes
Columnas
Hochschranke

H. 210

Riempitivo per colonna

Tall unit filler
Fileur pour colonne
Regleta para columna
Hochschrankfüller



L/W	CODICE	0	1	2	3	4	5	6	7	8	9	10
4-15	KCN902100151	146	161	190	244	258	268	296	354	438	525	575

Riempitivo per colonna 2 frontali

Tall unit filler 2 fronts
fileur pour colonnes 2 façades
Regleta para columna 2 frentes
Hochschrankfüller 2 Fronten



L/W	CODICE	0	1	2	3	4	5	6	7	8	9	10
4-15	KCN922100151	149	168	198	253	267	275	304	364	451	540	590

Riempitivo per colonna 2 frontali

Tall unit filler 2 fronts
fileur pour colonnes 2 façades
Regleta para columna 2 frentes
Hochschrankfüller 2 Fronten



L/W	CODICE	0	1	2	3	4	5	6	7	8	9	10
4-15	KCN912100151	149	168	198	253	267	275	304	364	451	540	590

COLONNE

Tall units
Colonnes
Columns
Hochschränke

H. 210

Colonna 1 anta

Tall unit 1 door
Colonne 1 porte
Columna 1 puerta
Hochschrank 1 Tür

Apertura con gola verticale o maniglia
Opening with vertical groove or handle
Ouverture avec rainure verticale ou poignée
Apertura con uñero vertical o tirador
Öffnung mit vertikaler Griffleiste

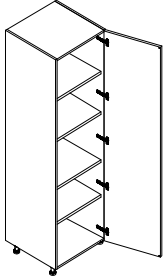

P/D	L/W	CODICE	0	1	2	3	4	5	6	7	8	9	10
34	30	KCN012100301	262	277	303	405	415	433	467	553	648	779	911
34	45	KCN012100451	298	314	371	474	493	512	567	679	841	1.009	1.145
34	60	KCN012100601	326	345	436	550	572	617	691	828	1.025	1.228	1.379
34	75	KCN012100751	391	414	524	661	688	739	828	995	1.230	1.475	1.619
57	30	KCN012100304	306	320	348	464	492	502	510	599	703	843	947
57	45	KCN012100454	340	358	416	518	557	570	610	724	894	1.073	1.188
57	60	KCN012100604	373	397	487	599	649	663	737	877	1.086	1.301	1.429
57	75	KCN012100754	448	475	585	720	780	793	885	1.052	1.303	1.562	1.676
67	30	KCN012100307	326	340	369	484	514	521	529	620	726	872	974
67	45	KCN012100457	361	377	437	537	572	590	629	738	919	1.103	1.219
67	60	KCN012100607	396	413	506	619	657	680	756	895	1.107	1.329	1.464
67	75	KCN012100757	474	496	608	741	801	817	906	1.075	1.328	1.595	1.715

Colonna 1 anta + 2 cestoni + 2 cassetti interni

Tall unit 1 door + 2 baskets + 2 internal drawers
Colonne 1 porte + 2 paniers + 2 tiroirs intérieurs
Columna 1 puerta + 2 cestas + 2 cajones interiores
Hochschrank 1 Tür + 2 Schubkasten + 2 Innenschubladen

Apertura con gola verticale o maniglia
Opening with vertical groove or handle
Ouverture avec rainure verticale ou poignée
Apertura con uñero vertical o tirador
Öffnung mit vertikaler Griffleiste

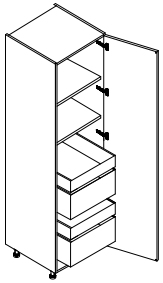

P/D	L/W	CODICE	0	1	2	3	4	5	6	7	8	9	10
57	45	KCK122100454	937	954	1.030	1.157	1.170	1.198	1.221	1.348	1.650	1.979	2.079
57	60	KCK122100604	967	993	1.105	1.245	1.284	1.322	1.358	1.511	1.852	2.222	2.322
57	75	KCK122100754	1.047	1.076	1.202	1.366	1.414	1.455	1.506	1.430	2.065	2.482	2.582
67	45	KCK122100457	922	940	1.022	1.160	1.176	1.205	1.233	1.368	1.692	2.031	2.131
67	60	KCK122100607	980	1.002	1.105	1.256	1.299	1.336	1.380	1.545	1.914	2.295	2.395
67	75	KCK122100757	1.054	1.082	1.207	1.380	1.433	1.471	1.533	1.725	2.135	2.561	2.661

Colonna 2 ante

Tall unit 2 doors
Colonne 2 portes
Columna 2 puertas
Hochschrank 2 Türen

Apertura solo con maniglia
Opening with handle only
Ouverture seulement avec la poignée
Apertura sólo con tirador
Öffnung nur mit Griff

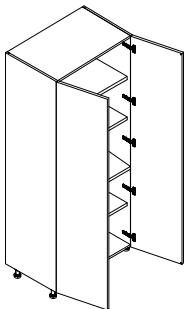

P/D	L/W	CODICE	0	1	2	3	4	5	6	7	8	9	10
34	90	KCN022100901	457	524	674	802	820	989	1.032	1.332	1.647	1.977	2.195
57	90	KCN022100904	525	602	757	883	910	1.065	1.110	1.441	1.780	2.135	2.259
67	90	KCN022100907	554	631	783	910	937	1.091	1.136	1.469	1.813	2.176	2.302

Basi con maniglia
Base units with handle

Basi con gola
Base units with groove

Colonne
Tall units

Pensili
Wall units

Elementi speciali
Special elements

Maniglie gole zoccoli
Handles grooves plinth

Illuminazione
Lighting

Accessori
Accessories

Componenti e meccanismi
Components e mechanism

COLONNE

Tall units
Colonnes
Columnas
Hochschranke

H. 210

Colonna 2 ante
Tall unit 2 doors
Colonne 2 portes
Columna 2 puertas
Hochschrank 2 Türen

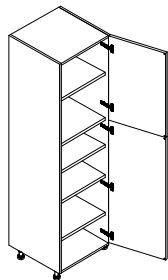

Apertura con gola verticale o maniglia
Opening with vertical groove or handle
Ouverture avec rainure verticale ou poignée
Apertura con uñero vertical o tirador
Öffnung mit vertikaler Griffleiste

P/D	L/W	CODICE	0	1	2	3	4	5	6	7	8	9	10
34	30	KCN042100301	253	312	354	405	423	461	495	593	733	880	966
34	45	KCN042100451	272	339	416	476	499	569	617	733	909	1.089	1.224
34	60	KCN042100601	304	378	474	566	590	658	755	894	1.108	1.330	1.482
34	75	KCN042100751	365	453	569	679	707	790	904	1.074	1.329	1.597	1.746
57	30	KCN042100304	321	361	405	452	490	507	537	642	789	947	1.004
57	45	KCN042100454	340	401	483	537	583	631	677	796	982	1.178	1.271
57	60	KCN042100604	355	437	537	624	675	716	812	953	1.177	1.410	1.537
57	75	KCN042100754	427	525	645	749	812	859	976	1.143	1.413	1.692	1.809
67	30	KCN042100307	341	377	426	471	506	527	559	658	813	974	1.032
67	45	KCN042100457	361	420	501	560	601	651	695	816	1.006	1.206	1.303
67	60	KCN042100607	374	457	558	644	695	733	827	971	1.196	1.436	1.574
67	75	KCN042100757	449	547	669	773	834	882	993	1.167	1.436	1.723	1.852

Colonna 4 ante
Tall unit 4-doors
Colonne 4 portes
Columna 4 puertas
4-türige Hochschrank

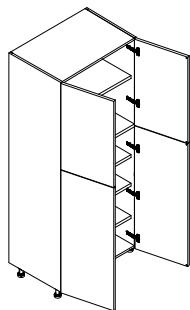

Apertura solo con maniglia
Opening with handle only
Ouverture seulement avec la poignée
Apertura sólo con tirador
Öffnung nur mit Griff

P/D	L/W	CODICE	0	1	2	3	4	5	6	7	8	9	10
34	90	KCN062100901	457	524	674	802	820	989	1.032	1.332	1.647	1.977	2.351
57	90	KCN062100904	525	602	757	883	910	1.065	1.110	1.441	1.780	2.135	2.423
67	90	KCN062100907	554	631	783	910	937	1.091	1.136	1.469	1.813	2.176	2.470

Colonna 2 ante
Tall unit 2 doors
Colonne 2 portes
Columna 2 puertas
Hochschrank 2 Türen

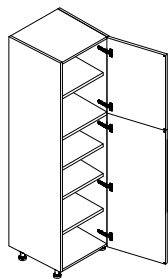

Apertura con gola verticale o maniglia
Opening with vertical groove or handle
Ouverture avec rainure verticale ou poignée
Apertura con uñero vertical o tirador
Öffnung mit vertikaler Griffleiste

P/D	L/W	CODICE	0	1	2	3	4	5	6	7	8	9	10
34	30	KCN032100301	253	312	354	405	423	461	495	593	733	880	966
34	45	KCN032100451	272	339	416	476	499	569	617	733	909	1.089	1.224
34	60	KCN032100601	304	378	474	566	590	658	755	894	1.108	1.330	1.482
34	75	KCN032100751	365	453	569	679	707	790	904	1.074	1.329	1.597	1.746
57	30	KCN032100304	321	361	405	452	490	507	537	642	789	947	1.004
57	45	KCN032100454	340	401	483	537	583	631	677	796	982	1.178	1.271
57	60	KCN032100604	355	437	537	624	675	716	812	953	1.177	1.410	1.537
57	75	KCN032100754	427	525	645	749	812	859	976	1.143	1.413	1.692	1.809
67	30	KCN032100307	341	377	426	471	506	527	559	658	813	974	1.032
67	45	KCN032100457	361	420	501	560	601	651	695	816	1.006	1.206	1.303
67	60	KCN032100607	374	457	558	644	695	733	827	971	1.196	1.436	1.574
67	75	KCN032100757	449	547	669	773	834	882	993	1.167	1.436	1.723	1.852

COLONNE

Tall units
Colonnes
Columnas
Hochschränke

H. 210

Colonna 4 ante

Tall unit 4-doors
Colonne 4 portes
Columna 4 puertas
4-türige Hochschrank

Apertura solo con maniglia

Opening with handle only
Ouverture seulement avec la poignée
Apertura sólo con tirador
Öffnung nur mit Griff

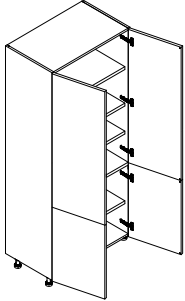

P/D	L/W	CODICE	0	1	2	3	4	5	6	7	8	9	10
34	90	KCN052100901	457	524	674	802	820	989	1.032	1.332	1.647	1.977	2.351
57	90	KCN052100904	525	602	757	883	910	1.065	1.110	1.441	1.780	2.135	2.423
67	90	KCN052100907	554	631	783	910	937	1.091	1.136	1.469	1.813	2.176	2.470

Colonna 2 ante + 2 cestoni + 2 cassetti interni

Tall unit 2 doors + 2 deep drawers
Colonne 2 portes + 2 paniers + 2 tiroirs intérieurs
Columna 2 puertas + 2 cajones interiores
Hochschrank 2 Türen + 2 Auszüge + 2 Schubkasten

Apertura con gola verticale o maniglia

Opening with vertical groove or handle
Ouverture avec rainure verticale ou poignée
Apertura con uñero vertical o tirador
Öffnung mit vertikaler Griffleiste

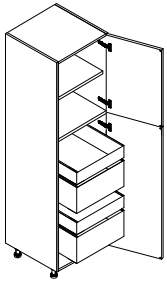

P/D	L/W	CODICE	0	1	2	3	4	5	6	7	8	9	10
57	45	KCK142100454	937	954	1.030	1.157	1.170	1.198	1.221	1.348	1.650	1.979	2.079
57	60	KCK142100604	967	993	1.105	1.245	1.284	1.322	1.358	1.511	1.852	2.222	2.322
57	75	KCK142100754	1.047	1.076	1.202	1.366	1.414	1.455	1.506	1.430	2.065	2.482	2.582
67	45	KCK142100457	922	940	1.022	1.160	1.176	1.205	1.233	1.368	1.692	2.031	2.131
67	60	KCK142100607	980	1.002	1.105	1.256	1.299	1.336	1.380	1.545	1.914	2.295	2.395
67	75	KCK142100757	1.054	1.082	1.207	1.380	1.433	1.471	1.533	1.725	2.135	2.561	2.661

Colonna 1 anta + 1 estraibile + 1 cestone interno

Tall unit 1 door + 1 pull-out + 1 inner basket
Colonne 1 porte + 1 extractible + 1 tiroir intérieur
Columna 1 puerta + 1 extraíble + 1 cajón interior
Hochschrank 1 Tür + 1 Auszug + 1 Innenschubkasten

Apertura con gola verticale o maniglia

Opening with vertical groove or handle
Ouverture avec rainure verticale ou poignée
Apertura con uñero vertical o tirador
Öffnung mit vertikaler Griffleiste

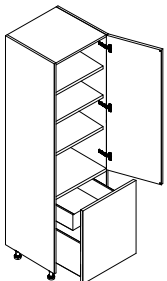

P/D	L/W	CODICE	0	1	2	3	4	5	6	7	8	9	10
57	45	KCN202100454	586	632	693	739	744	812	915	983	1.033	1.132	1.527
57	60	KCN202100604	659	705	787	833	868	936	1.101	1.169	1.206	1.370	1.806
57	75	KCN202100754	747	793	896	943	1.002	1.070	1.285	1.353	1.413	1.623	2.101
67	45	KCN202100457	634	681	741	788	793	861	964	1.032	1.083	1.182	1.577
67	60	KCN202100607	713	760	841	888	922	989	1.155	1.223	1.262	1.426	1.862
67	75	KCN202100757	806	854	956	1.003	1.062	1.130	1.344	1.412	1.474	1.684	2.162

Basi con maniglia
Base units with handle

Basi con gola
Base units with groove

Colonne
Tall units

Pensili
Wall units

Elementi speciali
Special elements

Maniglie gole zoccoli
Handles grooves plinth

Illuminazione
Lighting

Accessori
Accessories

Componenti e meccanismi
Components e mechanism

COLONNE

Tall units
Colonnes
Columnas
Hochschränke

H. 210

Colonna 1 anta + 4 cassetti

Tall unit 1 door + 4 drawers
Colonne 1 porte + 4 tiroirs
Columna 1 puerta + 4 cajones
Hochschrank 1 Tür + 4 Schubladen

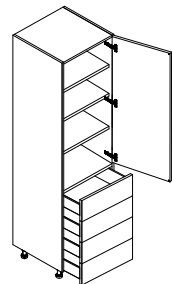

Apertura con gola verticale o maniglia
Opening with vertical groove or handle
Ouverture avec rainure verticale ou poignée
Apertura con uñero vertical o tirador
Öffnung mit vertikaler Griffleiste

P/D	L/W	CODICE	0	1	2	3	4	5	6	7	8	9	10
57	45	KCN242100454	641	688	782	828	870	938	1.046	1.114	1.433	1.296	1.791
57	60	KCN242100604	716	762	886	932	964	1.032	1.250	1.318	1.602	1.574	2.137
57	75	KCN242100754	793	840	991	1.038	1.073	1.141	1.464	1.532	1.773	1.775	2.486
67	45	KCN242100457	692	738	832	879	921	988	1.095	1.163	1.485	1.348	1.843
67	60	KCN242100607	773	820	942	988	1.021	1.089	1.308	1.375	1.660	1.633	2.196
67	75	KCN242100757	857	904	1.055	1.102	1.137	1.205	1.528	1.596	1.839	1.841	2.552

Colonna 1 anta + 2 cassetti + 1 cestone

Tall unit 1 door + 2 drawers + 1 basket
Colonne 1 porte + 2 tiroirs + 1 panier
Columna 1 puerta + 2 cajones + 1 cesta
Hochschrank 1 Tür + 2 Schubladen + 1 Schubkast

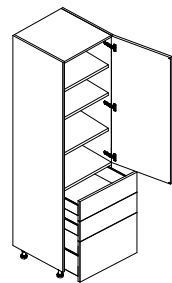

Apertura con gola verticale o maniglia
Opening with vertical groove or handle
Ouverture avec rainure verticale ou poignée
Apertura con uñero vertical o tirador
Öffnung mit vertikaler Griffleiste

P/D	L/W	CODICE	0	1	2	3	4	5	6	7	8	9	10
57	45	KCN232100454	594	640	724	770	788	856	966	1.034	1.265	1.218	1.673
57	60	KCN232100604	664	711	820	866	893	961	1.161	1.229	1.420	1.467	1.993
57	75	KCN232100754	739	786	922	968	1.011	1.079	1.363	1.431	1.580	1.673	2.318
67	45	KCN232100457	643	690	772	819	836	904	1.016	1.083	1.316	1.269	1.724
67	60	KCN232100607	720	766	875	922	949	1.017	1.216	1.284	1.477	1.523	2.050
67	75	KCN232100757	800	847	983	1.029	1.072	1.140	1.424	1.492	1.643	1.736	2.381

Colonna 1 anta + 2 cestoni

Tall unit 1 door + 2 baskets
Colonne 1 porte + 2 paniers
Columna 1 puerta + 2 cestas
Hochschrank 1 Tür + 2 Schubkasten

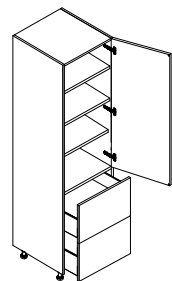

Apertura con gola verticale o maniglia
Opening with vertical groove or handle
Ouverture avec rainure verticale ou poignée
Apertura con uñero vertical o tirador
Öffnung mit vertikaler Griffleiste

P/D	L/W	CODICE	0	1	2	3	4	5	6	7	8	9	10
57	45	KCN222100454	546	593	664	711	705	773	888	955	1.097	1.140	1.555
57	60	KCN222100604	613	660	755	801	823	890	1.072	1.140	1.239	1.359	1.849
57	75	KCN222100754	685	731	851	897	949	1.017	1.261	1.329	1.387	1.570	2.149
67	45	KCN222100457	595	641	712	753	759	826	936	1.004	1.147	1.189	1.605
67	60	KCN222100607	665	713	808	855	876	944	1.125	1.193	1.294	1.414	1.904
67	75	KCN222100757	744	791	910	956	1.007	1.075	1.320	1.388	1.447	1.630	2.210

COLONNE

Tall units
Colonnes
Columnas
Hochschränke

H. 210

Colonna 1 anta + 2 cestoni

Tall unit 1 door + 2 baskets
Colonne 1 porte + 2 paniers
Columna 1 puerta + 2 cestas
Hochschrank 1 Tür + 2 Schubkasten

Apertura con gola orizzontale
Horizontal groove opening
Ouverture rainure horizontale
Apertura con uñero horizontal
Öffnung mit horizontaler Griffleiste

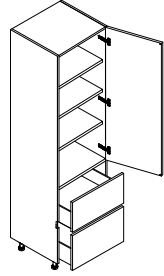

P/D	L/W	CODICE	0	1	2	3	4	5	6	7	8	9	10
57	45	KCG222100454	546	593	664	711	705	773	888	955	1.097	1.140	1.555
57	60	KCG222100604	613	660	755	801	823	890	1.072	1.140	1.239	1.359	1.849
57	75	KCG222100754	685	731	851	897	949	1.017	1.261	1.329	1.387	1.570	2.149
67	45	KCG222100457	595	641	712	753	759	826	936	1.004	1.147	1.189	1.605
67	60	KCG222100607	665	713	808	855	876	944	1.125	1.193	1.294	1.414	1.904
67	75	KCG222100757	744	791	910	956	1.007	1.075	1.320	1.388	1.447	1.630	2.210

Colonna 1 estraibile con meccanismo Linea Pro Sige

Tall unit 1 pull-out with mechanism Linea Pro Sige
Colonne 1 extractible avec mécanisme Linea Pro Sige
Columna 1 extraíble con mecanismo Linea Pro Sige
Hochschrank 1 Auszug mit Mechanismus Linea Pro Sige

Apertura con gola verticale o maniglia
Opening with vertical groove or handle
Ouverture avec rainure verticale ou poignée
Apertura con uñero vertical o tirador
Öffnung mit vertikaler Griffleiste

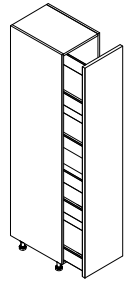

P/D	L/W	CODICE	0	1	2	3	4	5	6	7	8	9	10
57	30	KCN702100304	741	764	793	883	914	926	976	1.025	1.272	1.524	1.824
57	45	KCN702100454	831	851	880	993	1.046	1.080	1.113	1.224	1.512	1.814	2.114
67	30	KCN702100307	774	792	857	917	943	980	1.042	1.067	1.312	1.574	1.874
67	45	KCN702100457	857	877	904	1.016	1.071	1.104	1.137	1.247	1.538	1.845	2.145

Maggiorazione per meccanismo Linea Pure L. 30 Kessebohmer PUNTI 195

Mechanism Pure Line L. 30 Kessebohmer | Supplément pour le mécanisme Linea Pure L. 30 Kessebohmer | Recargo para mecanismo Linea Pure A.30 Kessebohmer | Aufpreis für Mechanismus Pure Line B. 30 Kessebohmer

Maggiorazione per meccanismo Linea Pure L. 45 Kessebohmer PUNTI 305

Mechanism Pure Line L. 45 Kessebohmer | Supplément pour le mécanisme Linea Pure L. 45 Kessebohmer | Recargo para mecanismo Linea Pure A.45 Kessebohmer | Aufpreis für Mechanik Pure Line B. 45 Kessebohmer

Colonna 2 estraibili con meccanismo Linea Pro Sige

Tall unit 2 pull-outs with mechanism Linea Pro Sige
Colonne 2 extractibles avec mécanisme Linea Pro Sige
Columna 2 extraíbles con mecanismo Linea Pro Sige
Hochschrank 2 Auszüge mit Mechanismus Linea Pro Sige

Apertura con gola verticale o maniglia
Opening with vertical groove or handle
Ouverture avec rainure verticale ou poignée
Apertura con uñero vertical o tirador
Öffnung mit vertikaler Griffleiste

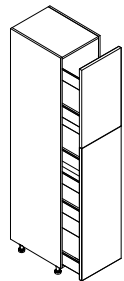

P/D	L/W	CODICE	0	1	2	3	4	5	6	7	8	9	10
57	30	KCN722100304	741	764	793	883	914	926	976	1.025	1.272	1.524	1.824
57	45	KCN722100454	831	851	880	993	1.046	1.080	1.113	1.224	1.512	1.814	2.114
67	30	KCN722100307	774	792	857	917	943	980	1.042	1.067	1.312	1.574	1.874
67	45	KCN722100457	857	877	904	1.016	1.071	1.104	1.137	1.247	1.538	1.845	2.145

Maggiorazione per meccanismo Linea Pure L. 30 Kessebohmer PUNTI 195

Mechanism Pure Line L. 30 Kessebohmer | Supplément pour le mécanisme Linea Pure L. 30 Kessebohmer | Recargo para mecanismo Linea Pure A.30 Kessebohmer | Aufpreis für Mechanismus Pure Line B. 30 Kessebohmer

Maggiorazione per meccanismo Linea Pure L. 45 Kessebohmer PUNTI 305

Mechanism Pure Line L. 45 Kessebohmer | Supplément pour le mécanisme Linea Pure L. 45 Kessebohmer | Recargo para mecanismo Linea Pure A.45 Kessebohmer | Aufpreis für Mechanik Pure Line B. 45 Kessebohmer

Basi con maniglia
Base units with handle

Basi con gola
Base units with groove

Colonne
Tall units

Pensili
Wall units

Elementi speciali
Special elements

Maniglie gole zoccoli
Handles grooves plinth

Illuminazione
Lighting

Accessori
Accessories

Componenti e meccanismi
Components e mechanism

COLONNE

Tall units
Colonnes
Columnas
Hochschränke

H. 210

Colonna 2 estraibili con meccanismo Linea Pro Sige

Tall unit 2 pull-outs with mechanism Linea Pro Sige
Colonne 2 extractibles avec mécanisme Linea Pro Sige
Columna 2 extraíbles con mecanismo Linea Pro Sige
Hochschrank 2 Auszüge mit Mechanismus Linea Pro Sige

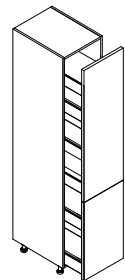

Apertura con gola verticale o maniglia
Opening with vertical groove or handle
Ouverture avec rainure verticale ou poignée
Apertura con uñero vertical o tirador
Öffnung mit vertikaler Griffleiste

P/D	L/W	CODICE	0	1	2	3	4	5	6	7	8	9	10
57	30	KCN712100304	741	764	793	883	914	926	976	1.025	1.272	1.524	1.824
57	45	KCN712100454	831	851	880	993	1.046	1.080	1.113	1.224	1.512	1.814	2.114
67	30	KCN712100307	774	792	857	917	943	980	1.042	1.067	1.312	1.574	1.874
67	45	KCN712100457	857	877	904	1.016	1.071	1.104	1.137	1.247	1.538	1.845	2.145

Maggiorazione per meccanismo Linea Pure L. 30 Kessebohmer PUNTI 195

Mechanism Pure Line L. 30 Kessebohmer | Supplément pour le mécanisme Linea Pure L. 30 Kessebohmer | Recargo para mecanismo Linea Pure A.30 Kessebohmer | Aufpreis für Mechanismus Pure Line B. 30 Kessebohmer

Maggiorazione per meccanismo Linea Pure L. 45 Kessebohmer PUNTI 305

Mechanism Pure Line L. 45 Kessebohmer | Supplément pour le mécanisme Linea Pure L. 45 Kessebohmer | Recargo para mecanismo Linea Pure A.45 Kessebohmer | Aufpreis für Mechanismus Pure Line B. 45 Kessebohmer

Colonna 1 anta con meccanismo Linea Pro Sige

Tall unit 1 door with mechanism Linea Pro Sige
Colonne 1 porte avec mécanisme Linea Pro Sige
Columna 1 puerta con mecanismo Linea Pro Sige
Hochschrank 1 Tür mit Mechanismus Linea Pro Sige

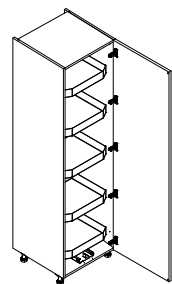

P/D	L/W	CODICE	0	1	2	3	4	5	6	7	8	9	10
57	60	KCN752100604	1.057	1.083	1.191	1.333	1.365	1.383	1.439	1.597	1.976	2.370	2.470
67	60	KCN752100607	1.075	1.100	1.211	1.352	1.383	1.404	1.458	1.614	1.998	2.396	2.496

Maggiorazione per meccanismo Arena Style Kessebohmer PUNTI 857

Mechanism Pure Kessebohmer Line | Supplément pour le mécanisme Arena Style Kessebohmer | Recargo para mecanismo Arena Style Kessebohmer | Aufpreis für Arena Style Kessebohmer Mechanismus

Colonna 1 anta con meccanismo Linea Pro Sige

Tall unit 1 door with mechanism Linea Pro Sige
Colonne 1 porte avec mécanisme Linea Pro Sige
Columna 1 puerta con mecanismo Linea Pro Sige
Hochschrank 1 Tür mit Mechanismus Linea Pro Sige

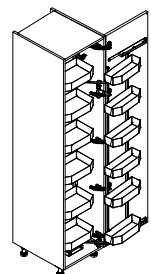

Apertura con gola verticale o maniglia
Opening with vertical groove or handle
Ouverture avec rainure verticale ou poignée
Apertura con uñero vertical o tirador
Öffnung mit vertikaler Griffleiste

P/D	L/W	CODICE	0	1	2	3	4	5	6	7	8	9	10
57	45	KCN742100454	1.104	1.217	1.265	1.386	1.393	1.436	1.453	1.594	1.973	2.367	2.467
57	60	KCN742100604	1.176	1.299	1.368	1.520	1.538	1.560	1.654	1.800	2.226	2.673	2.776
67	45	KCN742100457	1.123	1.235	1.285	1.405	1.412	1.455	1.472	1.612	1.996	2.394	2.494
67	60	KCN742100607	1.194	1.318	1.388	1.538	1.560	1.579	1.673	1.820	2.250	2.700	2.800

Maggiorazione per meccanismo Linea Pure L. 45 Kessebohmer PUNTI 438

Arena Style Kessebohmer mechanism | Supplément pour le mécanisme Linea Pure L. 45 Kessebohmer | Recargo para mecanismo Linea Pure A.45 Kessebohmer | Aufpreis für Mechanismus Pure Line B. 45 Kessebohmer

Maggiorazione per meccanismo Linea Pure L. 60 Kessebohmer PUNTI 657

Mechanism Pure Line L. 60 Kessebohmer | Supplément pour le mécanisme Linea Pure L. 60 Kessebohmer | Recargo para mecanismo Linea Pure A.60 Kessebohmer | Aufpreis für Mechanismus Pure Line L. 60 Kessebohmer

COLONNE

Tall units
Colonnes
Columnas
Hochschränke

H. 210

Colonna 1 anta portascopio

Tall unit 1-door broom
Colonne 1 porte pour balai
Columna 1 puerta para escobas
Hochschrank 1 Tür Besenstiel

Apertura con gola verticale o maniglia
Opening with vertical groove or handle
Ouverture avec rainure verticale ou poignée
Apertura con uñero vertical o tirador
Öffnung mit vertikaler Griffleiste

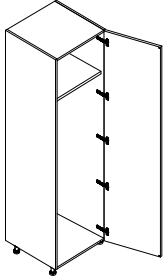

P/D	L/W	CODICE	0	1	2	3	4	5	6	7	8	9	10
57	45	KCN072100454	452	534	608	687	736	824	876	1.020	1.247	1.544	1.644
57	60	KCN072100604	543	643	736	824	905	987	1.100	1.274	1.561	1.931	2.031
67	45	KCN072100457	474	558	631	707	756	845	896	1.042	1.274	1.575	1.675
67	60	KCN072100607	564	666	760	869	928	1.011	1.124	1.296	1.588	1.962	2.062

Colonna 1 anta lavatrice - asciugatrice

Tall unit 1 door washer-dryer
Colonne 1 porte lave-linge- sèche-linge
Columna 1 puerta lavadora-secadora
Hochschrank 1 Tür Waschmaschine - Trockner

Apertura con gola verticale o maniglia
Opening with vertical groove or handle
Ouverture avec rainure verticale ou poignée
Apertura con uñero vertical o tirador
Öffnung mit vertikaler Griffleiste

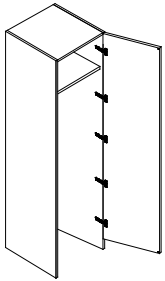

P/D	L/W	CODICE	0	1	2	3	4	5	6	7	8	9	10
67	69	KCN082100697	377	440	534	647	699	737	832	977	1.207	1.449	1.549

Colonna 2 ante lavatrice - asciugatrice

Tall unit 2 door washer-dryer
Colonne 2 portes lave-linge- sèche-linge
Columna 2 puertas lavadora-secadora
2-türige Waschmaschinen-Trockner-Hochschrank

Apertura con gola verticale o maniglia
Opening with vertical groove or handle
Ouverture avec rainure verticale ou poignée
Apertura con uñero vertical o tirador
Öffnung mit vertikaler Griffleiste

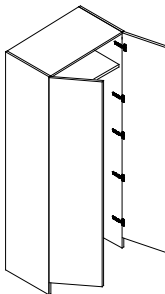

P/D	L/W	CODICE	0	1	2	3	4	5	6	7	8	9	10
67	90	KCN092100907	445	508	602	715	767	805	900	1.045	1.277	1.519	1.619

Basi con maniglia
Base units with handle

Basi con gola
Base units with groove

Colonne
Tall units

Pensili
Wall units

Elementi speciali
Special elements

Maniglie gole zoccoli
Handles grooves plinth

Illuminazione
Lighting

Accessori
Accessories

Componenti e meccanismi
Components e mechanism

COLONNE

Tall units
Colonnes
Columnas
Hochschränke

H. 210

Colonna angolo 1 anta
Corner tall unit 1 door
Colonne d'angle 1 porte
Columna ángulo 1 puerta
Eckehochschrank 1 Tür

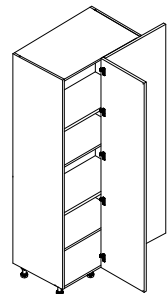

Apertura con gola verticale o maniglia
Opening with vertical groove or handle
Ouverture avec rainure verticale ou poignée
Apertura con uñero vertical o tirador
Öffnung mit vertikaler Griffleiste

	P/D	L/W	CODICE	0	1	2	3	4	5	6	7	8	9	10
○	59,5	110	KCA012101104D/S	828	855	937	1.148	1.219	1.285	1.349	1.603	1.984	2.381	2.481
▲	59,5	120	KCA012101204D/S	857	888	1.003	1.221	1.320	1.386	14.722	1.755	2.169	2.604	2.704
○	69,5	110	KCA012101107D/S	855	883	968	1.183	1.258	1.326	1.391	1.654	2.046	2.455	2.555
▲	69,5	120	KCA012101207D/S	884	915	1.036	1.260	1.363	1.430	1.517	1.808	2.237	2.684	2.784

- **scocca da 90 cm** | 90 cm body | structure de 90 cm | estructura de 90 cm | 90 cm Korpus
- ▲ **scocca da 105 cm** | 105 cm body | structure de 105 cm | estructura de 105 cm | 105 cm Korpus

Colonna angolo 2 ante
Corner tall unit 2 doors
Colonne d'angle 2 portes
Columna ángulo 2 puertas
Eckehochschrank 2 Türen

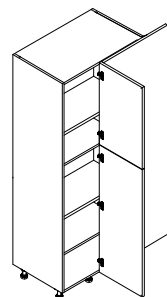

Apertura con gola verticale o maniglia
Opening with vertical groove or handle
Ouverture avec rainure verticale ou poignée
Apertura con uñero vertical o tirador
Öffnung mit vertikaler Griffleiste

	P/D	L/W	CODICE	0	1	2	3	4	5	6	7	8	9	10
○	59,5	110	KCA042101104D/S	828	855	937	1.148	1.219	1.285	1.349	1.603	1.984	2.381	2.481
▲	59,5	120	KCA042101204D/S	857	888	1.003	1.221	1.320	1.386	14.722	1.755	2.169	2.604	2.704
○	69,5	110	KCA042101107D/S	855	883	968	1.183	1.258	1.326	1.391	1.654	2.046	2.455	2.555
▲	69,5	120	KCA042101207D/S	884	915	1.036	1.260	1.363	1.430	1.517	1.808	2.237	2.684	2.784

- **scocca da 90 cm** | 90 cm body | structure de 90 cm | estructura de 90 cm | 90 cm Korpus
- ▲ **scocca da 105 cm** | 105 cm body | structure de 105 cm | estructura de 105 cm | 105 cm Korpus

Colonna angolo 2 ante
Corner tall unit 2 doors
Colonne d'angle 2 portes
Columna ángulo 2 puertas
Eckehochschrank 2 Türen

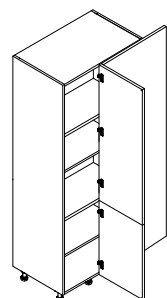

Apertura con gola verticale o maniglia
Opening with vertical groove or handle
Ouverture avec rainure verticale ou poignée
Apertura con uñero vertical o tirador
Öffnung mit vertikaler Griffleiste

	P/D	L/W	CODICE	0	1	2	3	4	5	6	7	8	9	10
○	59,5	110	KCA032101104D/S	828	855	937	1.148	1.219	1.285	1.349	1.603	1.984	2.381	2.481
▲	59,5	120	KCA032101204D/S	857	888	1.003	1.221	1.320	1.386	14.722	1.755	2.169	2.604	2.704
○	69,5	110	KCA032101107D/S	855	883	968	1.183	1.258	1.326	1.391	1.654	2.046	2.455	2.555
▲	69,5	120	KCA032101207D/S	884	915	1.036	1.260	1.363	1.430	1.517	1.808	2.237	2.684	2.784

- **scocca da 90 cm** | 90 cm body | structure de 90 cm | estructura de 90 cm | 90 cm Korpus
- ▲ **scocca da 105 cm** | 105 cm body | structure de 105 cm | estructura de 105 cm | 105 cm Korpus

COLONNE

Tall units
Colonnes
Columns
Hochschränke

H. 210

Colonna angolo 1 ante con meccanismo Linea Pro Sige
Corner tall unit 1 door with mechanism Linea Pro Sige
Colonne d'angle 1 porte avec mécanisme Linea Pro Sige
Columna ángulo 1 puerta con mecanismo Linea Pro Sige
Eckehochschrank 1 Tür mit Mechanismus Linea Pro Sige

Apertura con gola verticale o maniglia
Opening with vertical groove or handle
Ouverture avec rainure verticale ou poignée
Apertura con uñero vertical o tirador
Öffnung mit vertikaler Griffleiste

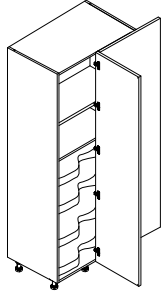

	P/D	L/W	CODICE	0	1	2	3	4	5	6	7	8	9	10
○	59,5	110	KCA762101104D/S	1.568	1.594	1.673	1.926	1.999	2.063	2.127	2.382	2.788	3.345	3.445
▲	59,5	125	KCA762101254D/S	1.698	1.729	1.837	2.104	2.203	2.270	2.353	2.635	3.079	3.695	3.795
○	69,5	120	KCA762101207D/S	1.614	1.641	1.723	1.985	2.059	2.124	2.191	2.453	2.872	3.445	3.555
▲	69,5	135	KCA762101357D/S	1.749	1.778	1.893	2.168	2.269	2.337	2.423	2.714	3.171	3.805	3.905

- **scocca da 90 cm** | 90 cm body | structure de 90 cm | estructura de 90 cm | 90 cm Korpus
- ▲ **scocca da 105 cm** | 105 cm body | structure de 105 cm | estructura de 105 cm | 105 cm Korpus

Maggiorazione per meccanismo Linea Pure Kessebohmer

Mechanism Pure Kessebohmer Line | Supplément pour le mécanisme Linea Pure Kessebohmer | Recargo para mecanismo Linea Pure Kessebohmer | Aufpreis für Mechanismus Pure Kessebohmer Line

Colonna angolo 2 ante con meccanismo Linea Pro Sige
Corner tall unit 2 doors with mechanism Linea Pro Sige
Colonne d'angle 2 portes avec mécanisme Linea Pro Sige
Columna ángulo 2 puertas con mecanismo Linea Pro Sige
2-türige Eckehochschrank mit Mechanismus Linea Pro Sige

Apertura con gola verticale o maniglia
Opening with vertical groove or handle
Ouverture avec rainure verticale ou poignée
Apertura con uñero vertical o tirador
Öffnung mit vertikaler Griffleiste

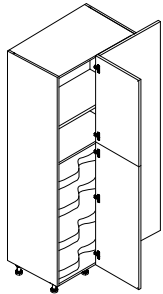

	P/D	L/W	CODICE	0	1	2	3	4	5	6	7	8	9	10
○	59,5	110	KCA782101104D/S	1.568	1.594	1.673	1.926	1.999	2.063	2.127	2.382	2.788	3.345	3.445
▲	59,5	125	KCA782101254D/S	1.698	1.729	1.837	2.104	2.203	2.270	2.353	2.635	3.079	3.695	3.795
○	69,5	120	KCA782101207D/S	1.614	1.641	1.723	1.985	2.059	2.124	2.191	2.453	2.872	3.445	3.555
▲	69,5	135	KCA782101357D/S	1.749	1.778	1.893	2.168	2.269	2.337	2.423	2.714	3.171	3.805	3.905

- **scocca da 90 cm** | 90 cm body | structure de 90 cm | estructura de 90 cm | 90 cm Korpus
- ▲ **scocca da 105 cm** | 105 cm body | structure de 105 cm | estructura de 105 cm | 105 cm Korpus

Maggiorazione per meccanismo Linea Pure Kessebohmer PUNTI 645

Mechanism Pure Kessebohmer Line | Supplément pour le mécanisme Linea Pure Kessebohmer | Recargo para mecanismo Linea Pure Kessebohmer | Aufpreis für Mechanismus Pure Kessebohmer Line

Colonna angolo 2 ante con meccanismo Linea Pro Sige
Corner tall unit 2 doors with mechanism Linea Pro Sige
Colonne d'angle 2 portes avec mécanisme Linea Pro Sige
Columna ángulo 2 puertas con mecanismo Linea Pro Sige
2-türige Eckehochschrank mit Mechanismus Linea Pro Sige

Apertura con gola verticale o maniglia
Opening with vertical groove or handle
Ouverture avec rainure verticale ou poignée
Apertura con uñero vertical o tirador
Öffnung mit vertikaler Griffleiste

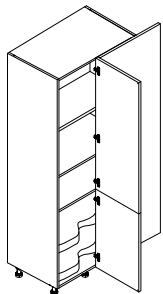

	P/D	L/W	CODICE	0	1	2	3	4	5	6	7	8	9	10
○	59,5	110	KCA772101104D/S	1.250	1.283	1.386	1.600	1.688	1.773	1.848	2.108	2.513	3.015	3.115
▲	59,5	125	KCA772101254D/S	1.336	1.367	1.492	1.733	1.833	1.911	2.031	2.315	2.760	3.311	3.411
○	69,5	120	KCA772101207D/S	1.287	1.319	1.424	1.644	1.734	1.824	1.895	2.164	2.584	3.099	3.199
▲	69,5	135	KCA772101357D/S	1.373	1.405	1.529	1.777	1.883	1.957	2.083	2.374	2.828	3.395	3.495

- **scocca da 90 cm** | 90 cm body | structure de 90 cm | estructura de 90 cm | 90 cm Korpus
- ▲ **scocca da 105 cm** | 105 cm body | structure de 105 cm | estructura de 105 cm | 105 cm Korpus

Maggiorazione per meccanismo Linea Pure Kessebohmer PUNTI 269

Mechanism Pure Kessebohmer Line | Supplément pour le mécanisme Linea Pure Kessebohmer | Recargo para mecanismo Linea Pure Kessebohmer | Aufpreis für Mechanismus Pure Kessebohmer Line

Basi con maniglia
Base units with handle

Basi con gola
Base units with groove

Colonne
Tall units

Pensili
Wall units

Elementi speciali
Special elements

Maniglie gole zoccoli
Handles grooves plinth

Illuminazione
Lighting

Accessori
Accessories

Componenti e meccanismi
Components e mechanism

COLONNE

Tall units
Colonne
Columnas
Hochschranke

H. 210

Cabina angolo 1 anta

Corner pantry 1 door
Dressing d'angle 1 porte
Cabina ángulo 1 puerta
Eckkabine 1 Tür

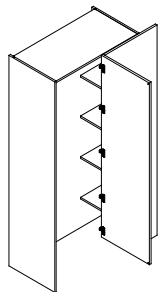

Apertura con gola verticale o maniglia
Opening with vertical groove or handle
Ouverture avec rainure verticale ou poignée
Apertura con uñero vertical o tirador
Öffnung mit vertikaler Griffleiste

P/D	L/W	CODICE	0	1	2	3	4	5	6	7	8	9	10
80	150	KCB012101508D/S	2.013	2.117	2.221	2.536	2.743	2.901	3.111	3.424	4.016	4.448	4.848

Colonna 1 anta copriboiler

Tall unit 1 door for water header / boiler
Colonne 1 porte pour cumulus
Columna 1 puerta para cubrir un boiler
Abdeckung der Wasser-warme

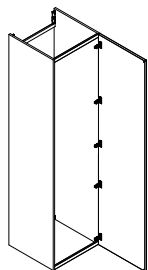

Apertura con gola verticale o maniglia
Opening with vertical groove or handle
Ouverture avec rainure verticale ou poignée
Apertura con uñero vertical o tirador
Öffnung mit vertikaler Griffleiste

P/D	L/W	CODICE	0	1	2	3	4	5	6	7	8	9	10
57	60	KCD012100604	402	430	469	532	541	587	634	728	863	1.037	1.087
67	60	KCD012100607	413	441	480	543	553	598	646	740	875	1.049	1.099

COLONNE FORNO

Oven tall units
Colonnes four
Columnas horno
Backofen-Hochschranke

H. 210

Colonna forno 2 ante (frontale superiore su misura)

Oven tall unit 2 doors (upper front made to measure)
Colonne four 2 portes (façade supérieure sur mesure)
Columna horno 2 puertas (frontal superior a medida)
Backofenschrank 2 Türen (obere Front nach Maß)

Apertura con gola verticale o maniglia
Opening with vertical groove or handle
Ouverture avec rainure verticale ou poignée
Apertura con uñero vertical o tirador
Öffnung mit vertikaler Griffleiste

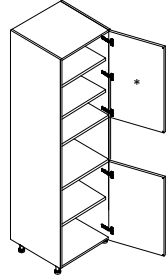

P/D	L/W	CODICE	0	1	2	3	4	5	6	7	8	9	10
57	60	KCP022100604	400	469	510	603	648	671	727	846	1.029	1.237	1.286
67	60	KCP022100607	420	485	530	622	665	689	742	862	1.053	1.263	1.321

* Frontale su misura | Customised front panel | Façade sur mesure | Frente medida especial | Fronten in Sondermasse

Colonna forno 2 ante

Oven tall unit 2 doors
Colonne four 2 portes
Columna horno 2 puertas
Backofenschrank 2 Türen

Apertura con gola verticale o maniglia
Opening with vertical groove or handle
Ouverture avec rainure verticale ou poignée
Apertura con uñero vertical o tirador
Öffnung mit vertikaler Griffleiste

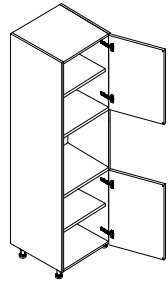

P/D	L/W	CODICE	0	1	2	3	4	5	6	7	8	9	10
57	60	KC0022100604	321	373	437	530	570	597	652	771	953	1.144	1.202
57	75	KC0022100754	372	433	507	614	663	791	756	893	1.104	1.326	1.415
67	60	KC0022100607	340	391	453	547	590	614	669	790	975	1.171	1.237
67	75	KC0022100757	395	453	526	635	683	713	775	916	1.130	1.357	1.454

□ forno L 75 cm | oven L 75 cm | four L 75 cm | horno L 75 cm | backofen B 75 cm

Colonna forno 1 anta + 1 estraibile + 1 cestone interno

Oven tall unit 1 door + 1 drawer + 1 inner basket
Colonne four 1 porte + 1 extractible + 1 tiroir intérieur
Columna horno 1 puerta + 1 cajón + 1 cajón interior
Backofenschrank 1 Tür + 1 Schublade + 1 Innenschubkast

Apertura con gola verticale o maniglia
Opening with vertical groove or handle
Ouverture avec rainure verticale ou poignée
Apertura con uñero vertical o tirador
Öffnung mit vertikaler Griffleiste

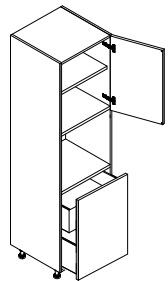

P/D	L/W	CODICE	0	1	2	3	4	5	6	7	8	9	10
57	60	KC0202100604	490	558	620	711	755	780	833	954	1.143	1.370	1.472
57	75	KC0202100754	598	646	718	825	874	903	965	1.106	1.325	1.588	1.707
67	60	KC0202100607	581	649	711	803	849	870	928	1.046	1.241	1.489	1.525
67	75	KC0202100757	708	754	825	931	983	1.010	1.073	1.211	1.438	1.725	1.765

□ forno L 75 cm | oven L 75 cm | four L 75 cm | horno L 75 cm | backofen B 75 cm

Basi con maniglia
Base units with handle

Basi con gola
Base units with groove

Colonne
Tall units

Pensili
Wall units

Elementi speciali
Special elements

Maniglie gole zoccoli
Handles grooves plinth

Illuminazione
Lighting

Accessori
Accessories

Componenti e meccanismi
Components e mechanism

COLONNE FORNO

Oven tall units
Colonnes four
Columnas horno
Backofen-Hochschränke

H. 210

Colonna forno 1 anta + 1 estraibile + 2 cassetti interni

Oven tall unit 1 door + 1 pull-out + 2 internal drawers
Colonne four 1 porte + 1 extractible + 2 tiroirs intérieurs
Columna horno 1 puerta + 1 extraíble + 2 cajones interiores
Backofenschrank 1 Tür + 1 Auszug + 2 Innenschubladen

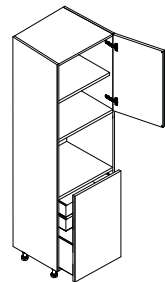

Apertura con gola verticale o maniglia
Opening with vertical groove or handle
Ouverture avec rainure verticale ou poignée
Apertura con uñero vertical o tirador
Öffnung mit vertikaler Griffleiste

P/D	L/W	CODICE	0	1	2	3	4	5	6	7	8	9	10
57	60	KC0212100604	558	626	688	779	823	848	901	1.021	1.213	1.440	1.542
57	75	KC0212100754	665	714	786	892	942	971	1.033	1.174	1.395	1.658	1.777
67	60	KC0212100607	649	717	779	871	917	938	996	1.114	1.311	1.559	1.595
67	75	KC0212100757	776	822	892	999	1.051	1.078	1.141	1.278	1.508	1.795	1.835

□ **forno L 75 cm** | oven L 75 cm | four L 75 cm | horno L 75 cm | backofen B 75 cm

Colonna forno 1 anta + 4 cassetti

Oven tall unit 1 door + 4 drawers
Colonne four 1 porte + 4 tiroirs
Columna horno 1 puerta + 4 cajones
Backofenschrank 1 Tür + 4 Schubladen

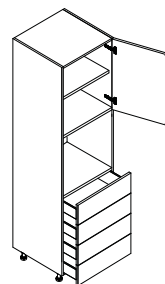

Apertura con gola verticale o maniglia
Opening with vertical groove or handle
Ouverture avec rainure verticale ou poignée
Apertura con uñero vertical o tirador
Öffnung mit vertikaler Griffleiste

P/D	L/W	CODICE	0	1	2	3	4	5	6	7	8	9	10
57	60	KC0242100604	614	718	792	921	962	978	1.053	1.180	1.459	1.751	1.803
57	75	KC0242100754	682	786	859	988	1.030	1.046	1.121	1.247	1.529	1.821	1.873
67	60	KC0242100607	792	796	973	1.104	1.139	1.160	1.228	1.355	1.678	2.014	2.114
67	75	KC0242100757	859	864	1.041	1.172	1.207	1.228	1.296	1.423	1.748	2.084	2.184

□ **forno L 75 cm** | oven L 75 cm | four L 75 cm | horno L 75 cm | backofen B 75 cm

Colonna forno 1 anta + 2 cassetti + 1 cestone

Oven tall unit 1 door + 2 drawers + 1 drawer
Colonne four 1 porte + 2 tiroirs + 1 tiroir
Columna horno 1 puerta + 2 cajones + 1 cajón
Backofenschrank 1 Tür + 2 Schubladen + 1 Schublade

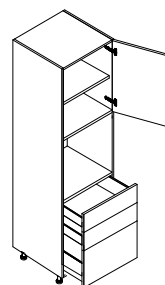

Apertura con gola verticale o maniglia
Opening with vertical groove or handle
Ouverture avec rainure verticale ou poignée
Apertura con uñero vertical o tirador
Öffnung mit vertikaler Griffleiste

P/D	L/W	CODICE	0	1	2	3	4	5	6	7	8	9	10
57	60	KC0232100604	566	661	731	849	900	920	956	1.104	1.362	1.634	1.734
57	75	KC0232100754	688	765	848	983	1.043	1.066	1.109	1.277	1.579	1.893	1.993
67	60	KC0232100607	702	799	877	991	1.041	1.067	1.094	1.243	1.531	1.839	1.939
67	75	KC0232100757	857	926	1.016	1.148	1.207	1.238	1.269	1.440	1.775	2.130	2.230

□ **forno L 75 cm** | oven L 75 cm | four L 75 cm | horno L 75 cm | backofen B 75 cm

COLONNE FORNO

Oven tall units
Colonnes four
Columnas horno
Backofen-Hochschranke

H. 210

Colonna forno 1 anta + 2 cestoni

Oven tall unit 1 door + 2 baskets
Colonne four 1 porte + 2 paniers
Columna horno 1 puerta + 2 cestas
Backofenschrank 1 Tür + 2 Schubkasten

Apertura con gola verticale o maniglia
Opening with vertical groove or handle
Ouverture avec rainure verticale ou poignée
Apertura con uñero vertical o tirador
Öffnung mit vertikaler Griffleiste

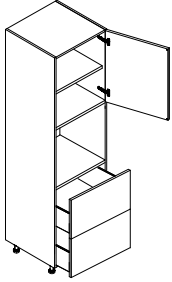

P/D	L/W	CODICE	0	1	2	3	4	5	6	7	8	9	10
57	60	KC0222100604	515	603	670	774	823	839	878	1.027	1.262	1.514	1.615
57	75	KC0222100754	629	699	777	897	953	972	1.016	1.191	1.462	1.755	1.855
67	60	KC0222100607	618	705	775	883	929	943	980	1.128	1.389	1.665	1.767
67	75	KC0222100757	754	818	899	1.022	1.077	1.091	1.135	1.308	1.609	1.929	2.029

□ forno L 75 cm | oven L 75 cm | four L 75 cm | horno L 75 cm | backofen B 75 cm

Colonna forno 1 anta + 2 cestoni

Oven tall unit 1 door + 2 baskets
Colonne four 1 porte + 2 paniers
Columna horno 1 puerta + 2 cestas
Backofenschrank 1 Tür + 2 Schubkasten

Apertura con gola orizzontale
Horizontal groove opening
Ouverture rainure horizontale
Apertura con uñero horizontal
Öffnung mit horizontaler Griffleiste

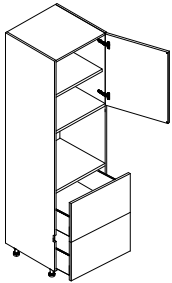

P/D	L/W	CODICE	0	1	2	3	4	5	6	7	8	9	10
57	60	KCH222100604	501	587	629	722	766	815	852	997	1.223	1.468	1.568
57	75	KCH222100754	568	655	696	790	834	883	920	1.065	1.293	1.538	1.638
67	60	KCH222100607	599	686	728	821	865	913	949	1.096	1.347	1.617	1.717
67	75	KCH222100757	667	754	796	889	933	981	1.017	1.164	1.417	1.687	1.787

□ forno L 75 cm | oven L 75 cm | four L 75 cm | horno L 75 cm | backofen B 75 cm

Colonna forno + microonde 1 anta + 1 cestone

Tall unit oven + microwave 1 door + 1 drawer
Colonne four + micro 1 porte + 1 panier
Columna horno + microondas 1 puerta + 1 cajón
Schrankofen + Mikrowelle 1 Tür + 1 Schublade

Apertura con gola verticale o maniglia
Opening with vertical groove or handle
Ouverture avec rainure verticale ou poignée
Apertura con uñero vertical o tirador
Öffnung mit vertikaler Griffleiste

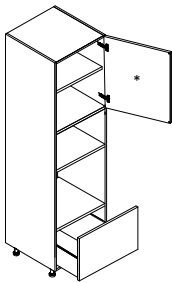

P/D	L/W	CODICE	0	1	2	3	4	5	6	7	8	9	10
57	60	KCM272100604	446	534	598	702	750	768	806	959	1.178	1.412	1.512
67	60	KCM272100607	506	594	662	764	815	830	867	1.016	1.253	1.503	1.603

* Frontale su misura | Customised front panel | Façade sur mesure | Frente medida especial | Fronten in Sondermasse

Basi con maniglia
Base units with handle

Basi con gola
Base units with groove

Colonne
Tall units

Pensili
Wall units

Elementi speciali
Special elements

Maniglie gole zoccoli
Handles grooves plinth

Illuminazione
Lighting

Accessori
Accessories

Componenti e meccanismi
Components e mechanism

COLONNE FORNO

Oven tall units
Colonnes four
Columnas horno
Backofen-Hochschränke

H. 210

Colonna forno + cantinetta 1 anta + 1 frontale fisso

Tall unit oven + wine cellar 1 door + 1 fixed front
Colonne four + cave à vin 1 porte + 1 façade fixe
Columna para horno+ espacio para vinos + 1 frente fijo
Schränken + Weinkeller 1 Tür + 1 feste Front

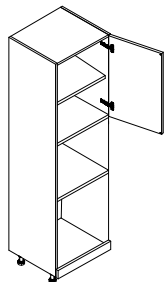

Apertura con gola verticale o maniglia
Opening with vertical groove or handle
Ouverture avec rainure verticale ou poignée
Apertura con uñero vertical o tirador
Öffnung mit vertikaler Griffleiste

P/D	L/W	CODICE	0	1	2	3	4	5	6	7	8	9	10
57	60	KCQ312100604	313	363	418	503	537	559	605	714	878	1.054	1.154
67	60	KCQ312100607	333	380	435	521	558	576	623	732	901	1.081	1.181

Colonna forno + microonde 2 ante

Oven tall unit + microwave 2 doors
Colonne four+ micro 2 portes
Horno columna + microondas 2 puertas
Schränken + Mikrowelle 2 Türen

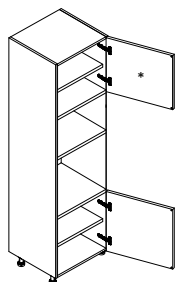

Apertura con gola verticale o maniglia
Opening with vertical groove or handle
Ouverture avec rainure verticale ou poignée
Apertura con uñero vertical o tirador
Öffnung mit vertikaler Griffleiste

P/D	L/W	CODICE	0	1	2	3	4	5	6	7	8	9	10
57	60	KCM022100604	339	409	476	574	592	624	670	765	933	1.116	1.216
67	60	KCM022100607	359	431	496	594	610	644	671	771	942	1.128	1.228

* **Frontale su misura** | Customised front panel | Façade sur mesure | Frente medida especial | Fronten in Sondermasse

Colonna forno + microonde 1 anta + 1 cassetto + 1 cestone

Tall unit oven + microwave 1 door + 1 drawer + 1 drawer
Colonne four + micro 1 porte + 1 tiroir + 1 panier
Columna horno + microondas 1 puerta + 1 cajón + 1 cajón
Schränken + Mikrowelle 1 Tür + 1 Schublade + 1 Schublade

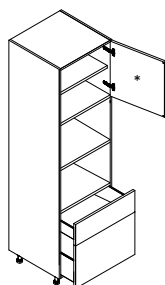

Apertura con gola verticale o maniglia
Opening with vertical groove or handle
Ouverture avec rainure verticale ou poignée
Apertura con uñero vertical o tirador
Öffnung mit vertikaler Griffleiste

P/D	L/W	CODICE	0	1	2	3	4	5	6	7	8	9	10
57	60	KCM282100604	552	610	680	784	832	849	886	1.036	1.275	1.528	1.628
67	60	KCM282100607	656	711	783	888	936	948	986	1.136	1.397	1.677	1.777

* **Frontale su misura** | Customised front panel | Façade sur mesure | Frente medida especial | Fronten in Sondermasse

COLONNE FORNO

Oven tall units
Colonnes four
Columnas horno
Backofen-Hochschränke

H. 210

Colonna forno + microonde 1 anta + 1 cassetto + 1 cestone

Tall unit oven + microwave 1 door + 1 drawer + 1 drawer
Colonne four + micro 1 porte + 1 tiroir + 1 panier
Columna horno + microondas 1 puerta + 1 cajón + 1 cajón
Schrankofen + Mikrowelle 1 Tür + 1 Schublade + 1 Schublade

Apertura con gola orizzontale
Horizontal groove opening
Ouverture rainure horizontale
Apertura con uñero horizontal
Öffnung mit horizontaler Griffleiste

P/D	L/W	CODICE	0	1	2	3	4	5	6	7	8	9	10
57	60	KCI282100604	552	610	680	784	832	849	886	1.036	1.275	1.528	1.628
67	60	KCI282100607	656	711	783	888	936	948	986	1.136	1.397	1.677	1.777

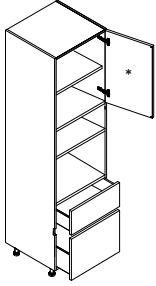

* Frontale su misura | Customised front panel | Façade sur mesure | Frente medida especial | Fronten in Sondermasse

Colonna forno sospesa 1 anta (sopra lavastoviglie)

Suspended oven tall unit 1 door (above dishwasher)
Colonne four suspendue 1 porte (au-dessus du lave-vaisselle)
Columna horno suspendida 1 puerta (sobre lavavajillas)
Haenge Backofenschrank 1 Tür (über Geschirrspüler)

Apertura con gola verticale o maniglia
Opening with vertical groove or handle
Ouverture avec rainure verticale ou poignée
Apertura con uñero vertical o tirador
Öffnung mit vertikaler Griffleiste

P/D	L/W	CODICE	0	1	2	3	4	5	6	7	8	9	10
57	60	KCS011320604	280	344	372	420	441	471	499	566	693	823	873
67	60	KCS011320607	289	353	381	433	457	485	514	583	712	848	898

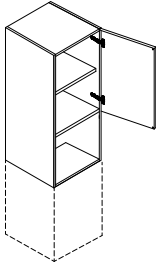

Colonna forno 2 ante + 2 cestoni

Oven tall unit 2 doors + 2 baskets
Colonne four 2 portes + 2 paniers
Columna horno 2 puertas + 2 cestas
Backofenschrank 2 Türen + 2 Schubkasten

Apertura con gola verticale o maniglia
Opening with vertical groove or handle
Ouverture avec rainure verticale ou poignée
Apertura con uñero vertical o tirador
Öffnung mit vertikaler Griffleiste

P/D	L/W	CODICE	0	1	2	3	4	5	6	7	8	9	10
57	90	KCO262100904	687	781	825	925	1.025	1.143	1.285	1.377	1.620	2.088	2.188
67	90	KCO262100907	755	849	892	993	1.093	1.211	1.353	1.445	1.690	2.158	2.258

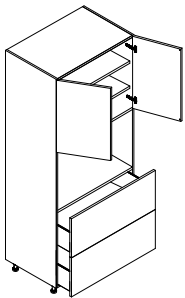

Basi con maniglia
Base units with handle

Basi con gola
Base units with groove

Colonne
Tall units

Pensili
Wall units

Elementi speciali
Special elements

Maniglie gole zoccoli
Handles grooves plinth

Illuminazione
Lighting

Accessori
Accessories

Componenti e meccanismi
Components e mechanism

COLONNE FORNO

Oven tall units
Colonnes four
Columnas horno
Backofen-Hochschränke

H. 210

Colonna forno H. 48 4 ante

Oven tall unit H 48 4 doors
Colonne four H 48 4 portes
Columna horno H 48 4 puertas
Backofenschrank H 48 4 Türen

Apertura solo con maniglia
Opening with handle only
Ouverture seulement avec la poignée
Apertura sólo con tirador
Öffnung nur mit Griff

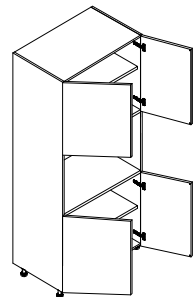

P/D	L/W	CODICE	0	1	2	3	4	5	6	7	8	9	10
57	90	KCP052100904	619	713	757	857	957	1.075	1.217	1.310	1.550	2.018	2.118
67	90	KCP052100907	687	781	825	925	1.025	1.143	1.285	1.377	1.620	2.088	2.188

Colonna forno H. 48 2 ante + 2 cestoni

Oven tall unit H 48 2 doors + 2 baskets
Colonne four H 48 2 portes + 2 paniers
Columna horno H 48 2 puertas + 2 cestas
Backofenschrank H 48 2 Türen + 2 Schubkasten

Apertura con gola orizzontale
Horizontal groove opening
Ouverture rainure horizontale
Apertura con uñero horizontal
Öffnung mit horizontaler Griffleiste

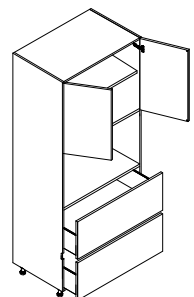

P/D	L/W	CODICE	0	1	2	3	4	5	6	7	8	9	10
57	90	KCJ262100904	687	781	825	925	1.025	1.143	1.285	1.377	1.620	2.088	2.188
67	90	KCJ262100907	755	849	892	993	1.093	1.211	1.353	1.445	1.690	2.158	2.258

Colonna angolo forno 2 ante

Corner tall unit for oven 2 doors
Colonne four d'angle 2 portes
Columna ángulo 2 puertas para horno
Backofen Ecke-Hochschrank 2 Türen

Apertura con gola verticale o maniglia
Opening with vertical groove or handle
Ouverture avec rainure verticale ou poignée
Apertura con uñero vertical o tirador
Öffnung mit vertikaler Griffleiste

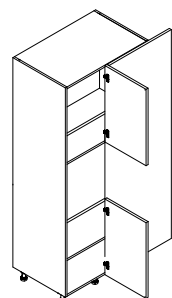

	P/D	L/W	CODICE	0	1	2	3	4	5	6	7	8	9	10
●	59,5	125	KCC022101254D/S	567	865	974	1.141	1.226	1.316	1.386	1.648	2.039	2.447	2.547
△	69,5	135	KCC022101357D/S	850	884	991	1.157	1.245	1.333	1.405	1.665	2.056	2.466	2.566

- **scocca da 75 cm** | 75 cm body | structure de 75 cm | estructura de 75 cm | 75 cm Korpus
- △ **scocca da 120 cm** | 120 cm body | structure de 120 cm | estructura de 120 cm | 120 cm Korpus

COLONNE FRIGO

Fridge tall units
Colonnes frigo
Columnas nevera
Kühlschrank Hochschränke

H. 210

Colonna frigo H. 122,5 2 ante

Refrigerator tall unit H 122,5 2 doors
Colonne frigo H 122,5 2 portes
Columna nevera H 122,5 2 puertas
Kühlschrank Hochschrank H 122,5 2 Türen

Apertura con gola verticale o maniglia
Opening with vertical groove or handle
Ouverture avec rainure verticale ou poignée
Apertura con uñero vertical o tirador
Öffnung mit vertikaler Griffleiste

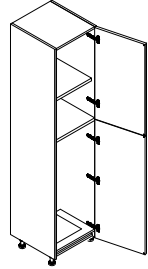

P/D	L/W	CODICE	0	1	2	3	4	5	6	7	8	9	10
57	60	KCF042100604	375	441	540	629	680	718	815	956	1.183	1.420	1.475
67	60	KCF042100607	397	464	562	647	699	737	832	977	1.207	1.449	1.502

Maggiorazione per apertura elettrica anta singola PUNTI 467

Surcharge for electric single door opening | Supplément pour ouverture électrique d'une porte seule | Recargo para apertura eléctrica puerta singular | Aufpreis für elektrische Türöffnung

Colonna frigo H. 178 1 anta

Refrigerator tall unit H 178 1 door
Colonne frigo H 178 1 porte
Columna nevera H 178 1 puerta
Kühlschrank Hochschrank H 178 1 Tür

Apertura con gola verticale o maniglia
Opening with vertical groove or handle
Ouverture avec rainure verticale ou poignée
Apertura con uñero vertical o tirador
Öffnung mit vertikaler Griffleiste

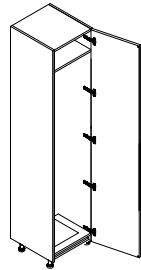

P/D	L/W	CODICE	0	1	2	3	4	5	6	7	8	9	10
57	60	KCF012100604	375	441	540	629	680	718	815	956	1.183	1.420	1.475
67	60	KCF012100607	397	464	562	647	699	737	832	977	1.207	1.449	1.502

Maggiorazione per apertura elettrica anta singola PUNTI 467

Surcharge for electric single door opening | Supplément pour ouverture électrique d'une porte seule | Recargo para apertura eléctrica puerta singular | Aufpreis für elektrische Türöffnung

Colonna frigo H. 178 2 ante

Refrigerator tall unit H 178 2 doors
Colonne frigo H 178 2 portes
Columna nevera H 178 2 puertas
Kühlschrank Hochschrank H 178 2 Türen

Apertura con gola verticale o maniglia
Opening with vertical groove or handle
Ouverture avec rainure verticale ou poignée
Apertura con uñero vertical o tirador
Öffnung mit vertikaler Griffleiste

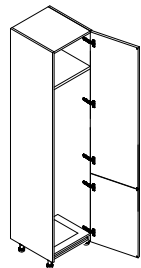

P/D	L/W	CODICE	0	1	2	3	4	5	6	7	8	9	10
57	60	KCF032100604	375	441	540	629	680	718	815	956	1.183	1.420	1.475
57	75	KCF032100754	451	530	649	755	817	861	978	111	1.420	1.704	1.743
67	60	KCF032100607	397	464	562	647	699	737	832	977	1.207	1.449	1.502
67	75	KCF032100757	475	557	673	779	840	885	998	1.173	1.449	1.739	1.772

Maggiorazione per apertura elettrica anta doppia PUNTI 934

Surcharge for electric double sash opening | Supplément pour l'ouverture électrique d'une porte double | Recargo para apertura eléctrica puerta doble | Aufpreis für elektrische Doppeltüröffnung

Basi con maniglia
Base units with handle

Basi con gola
Base units with groove

Colonne
Tall units

Pensili
Wall units

Elementi speciali
Special elements

Maniglie gole zoccoli
Handles grooves plinth

Illuminazione
Lighting

Accessori
Accessories

Componenti e meccanismi
Components e mechanism

COLONNE VETRINA

H. 210

Showcase tall units
Vitrine
Columnas vitrina
Glasstuer Hochschranke

Colonna vetrina 1 ante

Display tall unit 1 door
Vitrine 1 porte
Columna vitrina 1 puerta
Vitrinensäule 1 Tür

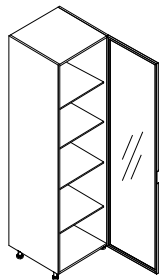

P/D	L/W	CODICE	0	1	2	3	4	5	6	7	8	9	10
34	45	KCV012100451	703	756	950	1.294	-	-	-	-	-	-	-
34	60	KCV012100601	807	868	1.090	1.485	-	-	-	-	-	-	-
57	45	KCV012100454	761	818	1.027	1.400	-	-	-	-	-	-	-
57	60	KCV012100604	891	958	1.203	1.640	-	-	-	-	-	-	-
67	45	KCV012100457	784	843	1.059	1.443	-	-	-	-	-	-	-
67	60	KCV012100607	916	984	1.236	1.685	-	-	-	-	-	-	-

Colonna vetrina 2 ante

Display tall unit 2 doors
Vitrine 2 portes
Columna vitrina 2 puertas
Hochschrank 2 Glasstüren

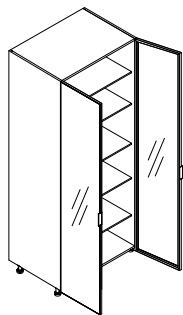

P/D	L/W	CODICE	0	1	2	3	4	5	6	7	8	9	10
34	90	KCV022100901	1.352	1.453	1.825	2.488	-	-	-	-	-	-	-
57	90	KCV022100904	1.385	1.489	1.869	2.548	-	-	-	-	-	-	-
67	90	KCV022100907	1.412	1.518	1.906	2.598	-	-	-	-	-	-	-

COLONNE USA

USA tall units
Colonnes américaines
Columns USA
US-Hochschränke

H. 210

Colonna USA (30") forno + microonde 2 ante + 1 cestone

USA tall unit (30") oven + microwave 2 doors + 1 drawer
Colonne USA (30") four + micro+ 2 portes + 1 panier
Columna USA (30") horno + microondas 2 puertas + 1 cajón
USA Hochschrank (30") Backofen + Mikrowelle 2 Türen + 1 Schublade

Apertura solo con maniglia

Opening with handle only
Ouverture seulement avec la poignée
Apertura sólo con tirador
Öffnung nur mit Griff

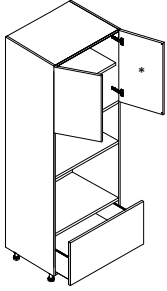

P/D	L/W	CODICE	0	1	2	3	4	5	6	7	8	9	10
57	76,2	KCM252100764	589	627	695	745	817	889	985	1.045	1.257	1.491	1.546
67	76,2	KCM252100767	657	695	763	813	885	956	1.052	1.113	1.327	1.561	1.616

* Frontale su misura | Customised front panel | Façade sur mesure | Frente medida especial | Fronten in Sondermasse

Colonna USA (30") forno 2 ante + 2 cestoni

USA tall unit (30") oven 2 doors + 2 baskets
Colonne USA C (30") four 2 portes + 2 paniers
Columna USA (30") horno 2 puertas + 2 cestas
USA Hochschrank (30") 2 Türen + 2 Schubkasten

Apertura con gola orizzontale

Horizontal groove opening
Ouverture rainure horizontale
Apertura con uñero horizontal
Öffnung mit horizontaler Griffleiste

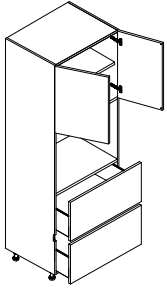

P/D	L/W	CODICE	0	1	2	3	4	5	6	7	8	9	10
57	76,2	KCH262100764	877	986	1.037	1.164	1.331	1.437	1.698	1.826	2.178	2.671	2.771
67	76,2	KCH262100767	945	1.053	1.105	1.232	1.399	1.504	1.765	1.893	2.248	2.741	2.841

Basi con maniglia
Base units with handle

Basi con gola
Base units with groove

Colonne
Tall units

Pensili
Wall units

Elementi speciali
Special elements

Maniglie gole zoccoli
Handles grooves plinth

Illuminazione
Lighting

Accessori
Accessories

Componenti e meccanismi
Components e mechanism

COLONNE

H. 225

Tall units
Colonnes
Columnas
Hochschränke

Riempitivo per colonna

Tall unit filler
Fileur pour colonne
Regleta para columna
Hochschrankfüller



L/W	CODICE	0	1	2	3	4	5	6	7	8	9	10
4-15	KCN902250151	141	168	198	253	265	275	304	364	451	541	591

Riempitivo per colonna 2 frontali

Tall unit filler 2 fronts
fileur pour colonnes 2 façades
Regleta para columna 2 frentes
Hochschrankfüller 2 Fronten



L/W	CODICE	0	1	2	3	4	5	6	7	8	9	10
4-15	KCN922250151	153	174	204	261	273	284	313	375	464	557	607

Riempitivo per colonna 2 frontali

Tall unit filler 2 fronts
fileur pour colonnes 2 façades
Regleta para columna 2 frentes
Hochschrankfüller 2 Fronten



L/W	CODICE	0	1	2	3	4	5	6	7	8	9	10
4-15	KCN912250151	153	174	204	261	273	284	313	375	464	557	607

COLONNE

Tall units
Colonnes
Columnas
Hochschränke

H. 225

Colonna 1 anta

Tall unit 1 door
Colonne 1 porte
Columna 1 puerta
Hochschrank 1 Tür

Apertura con gola verticale o maniglia
Opening with vertical groove or handle
Ouverture avec rainure verticale ou poignée
Apertura con uñero vertical o tirador
Öffnung mit vertikaler Griffleiste

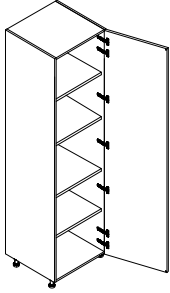

P/D	L/W	CODICE	0	1	2	3	4	5	6	7	8	9	10
34	30	KCN012250301	279	340	371	414	450	491	526	626	770	923	967
34	45	KCN012250451	298	366	432	485	528	577	652	755	928	1.113	1.215
34	60	KCN012250601	330	407	491	571	623	695	791	935	1.154	1.386	1.462
34	75	KCN012250751	398	475	559	639	691	762	858	1.003	1.224	1.456	1.532
57	30	KCN012250304	332	370	400	446	481	524	555	658	810	1.029	1.079
57	45	KCN012250454	348	415	476	532	571	651	695	819	1.007	1.281	1.331
57	60	KCN012250604	367	447	534	614	664	734	830	977	1.207	1.535	1.585
57	75	KCN012250754	435	515	601	682	732	802	898	1.045	1.277	1.605	1.655
67	30	KCN012250307	349	390	424	466	499	540	571	677	832	1.060	1.110
67	45	KCN012250457	370	433	498	552	593	666	714	836	1.030	1.311	1.361
67	60	KCN012250607	386	469	554	631	683	755	851	996	1.229	1.563	1.613
67	75	KCN012250757	454	536	622	699	751	823	919	1.064	1.299	1.633	1.683

Colonna 1 anta + 2 cestoni + 2 cassetti interni

Tall unit 1 door + 2 baskets + 2 internal drawers
Colonne 1 porte + 2 paniers + 2 tiroirs intérieurs
Columna 1 puerta + 2 cestas + 2 cajones interiores
Hochschrank 1 Tür + 2 Schubkasten + 2 Innenschubladen

Apertura con gola verticale o maniglia
Opening with vertical groove or handle
Ouverture avec rainure verticale ou poignée
Apertura con uñero vertical o tirador
Öffnung mit vertikaler Griffleiste

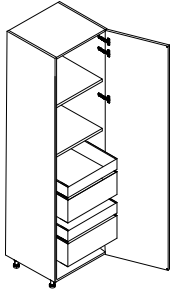

P/D	L/W	CODICE	0	1	2	3	4	5	6	7	8	9	10
57	45	KCK122250454	970	986	1.031	1.148	1.185	1.208	1.262	1.389	1.699	2.161	2.211
57	60	KCK122250604	1.012	1.036	1.107	1.235	1.283	1.324	1.404	1.558	1.907	2.425	2.475
57	75	KCK122250754	1.079	1.108	1.192	1.342	1.401	1.451	1.544	1.727	2.117	2.677	2.727
67	45	KCK122250457	1.073	1.088	1.132	1.249	1.288	1.310	1.365	1.493	1.827	2.322	2.372
67	60	KCK122250607	1.115	1.140	1.207	1.337	1.384	1.426	1.504	1.660	2.032	2.585	2.635
67	75	KCK122250757	1.181	1.211	1.292	1.443	1.503	1.552	1.645	1.828	2.243	2.837	2.887

Colonna 2 ante

Tall unit 2 doors
Colonne 2 portes
Columna 2 puertas
Hochschrank 2 Türen

Apertura solo con maniglia
Opening with handle only
Ouverture seulement avec la poignée
Apertura sólo con tirador
Öffnung nur mit Griff

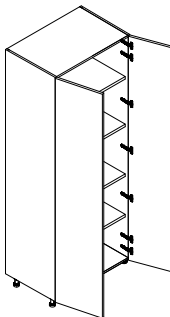

P/D	L/W	CODICE	0	1	2	3	4	5	6	7	8	9	10
34	90	KCN022250901	469	502	598	841	895	921	1.049	1.253	1.551	1.861	1.911
57	90	KCN022250904	525	560	651	895	952	974	1.057	1.338	1.654	2.104	2.396
67	90	KCN022250907	555	588	678	924	981	1.002	1.085	1.364	1.688	2.147	2.440

Basi con maniglia
Base units with handle

Basi con gola
Base units with groove

Colonne
Tall units

Pensili
Wall units

Elementi speciali
Special elements

Maniglie gole zoccoli
Handles grooves plinth

Illuminazione
Lighting

Accessori
Accessories

Componenti e meccanismi
Components e mechanism

COLONNE

Tall units
Colonnes
Columnas
Hochschranke

H. 225

Colonna 2 ante
Tall unit 2 doors
Colonne 2 portes
Columna 2 puertas
Hochschrank 2 Türen

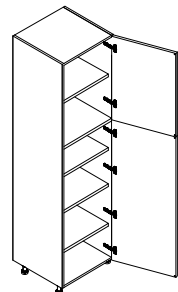

Apertura con gola verticale o maniglia
Opening with vertical groove or handle
Ouverture avec rainure verticale ou poignée
Apertura con uñero vertical o tirador
Öffnung mit vertikaler Griffleiste

P/D	L/W	CODICE	0	1	2	3	4	5	6	7	8	9	10
34	30	KCN042250301	279	340	371	414	450	491	526	626	770	923	1.027
34	45	KCN042250451	298	366	432	485	528	577	652	755	928	1.113	1.299
34	60	KCN042250601	330	407	491	571	623	695	791	935	1.154	1.386	1.571
34	75	KCN042250751	398	475	559	639	691	762	858	1.003	1.224	1.456	1.641
57	30	KCN042250304	332	370	404	446	481	524	555	658	810	1.029	1.069
57	45	KCN042250454	348	412	476	532	571	651	695	819	1.007	1.281	1.349
57	60	KCN042250604	367	447	534	614	664	734	830	977	1.207	1.535	1.629
57	75	KCN042250754	435	515	601	682	732	802	898	1.045	1.277	1.605	1.699
67	30	KCN042250307	349	390	424	466	499	540	571	677	832	1.060	1.098
67	45	KCN042250457	370	433	498	552	593	666	714	836	1.030	1.311	1.383
67	60	KCN042250607	386	469	554	631	683	755	851	996	1.229	1.563	1.668
67	75	KCN042250757	454	536	622	699	751	823	919	1.064	1.299	1.633	1.738

Colonna 4 ante
Tall unit 4-doors
Colonne 4 portes
Columna 4 puertas
4-türige Hochschrank

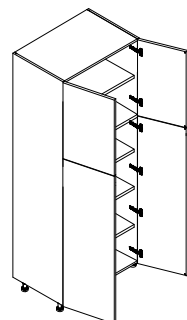

Apertura solo con maniglia
Opening with handle only
Ouverture seulement avec la poignée
Apertura sólo con tirador
Öffnung nur mit Griff

P/D	L/W	CODICE	0	1	2	3	4	5	6	7	8	9	10
34	90	KCN062250901	485	555	687	805	831	1.031	1.077	1.383	1.708	2.049	2.497
57	90	KCN062250904	540	620	750	865	892	1.094	1.139	1.477	1.826	2.321	2.571
67	90	KCN062250907	567	649	776	892	921	1.121	1.162	1.506	1.858	2.364	2.620

Colonna 2 ante
Tall unit 2 doors
Colonne 2 portes
Columna 2 puertas
Hochschrank 2 Türen

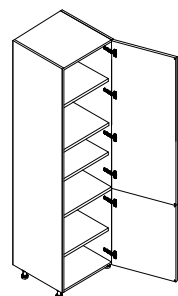

Apertura con gola verticale o maniglia
Opening with vertical groove or handle
Ouverture avec rainure verticale ou poignée
Apertura con uñero vertical o tirador
Öffnung mit vertikaler Griffleiste

P/D	L/W	CODICE	0	1	2	3	4	5	6	7	8	9	10
34	30	KCN032250301	279	340	371	414	450	491	526	626	770	923	1.027
34	45	KCN032250451	298	366	432	485	528	577	652	755	928	1.113	1.299
34	60	KCN032250601	330	407	491	571	623	695	791	935	1.154	1.386	1.571
34	75	KCN032250751	398	475	559	639	691	762	858	1.003	1.224	1.456	1.641
57	30	KCN032250304	332	370	404	446	481	524	555	658	810	1.029	1.069
57	45	KCN032250454	348	412	476	532	571	651	695	819	1.007	1.281	1.349
57	60	KCN032250604	367	447	534	614	664	734	830	977	1.207	1.535	1.629
57	75	KCN032250754	435	515	601	682	732	802	898	1.045	1.277	1.605	1.699
67	30	KCN032250307	349	390	424	466	499	540	571	677	832	1.060	1.098
67	45	KCN032250457	370	433	498	552	593	666	714	836	1.030	1.311	1.383
67	60	KCN032250607	386	469	554	631	683	755	851	996	1.229	1.563	1.668
67	75	KCN032250757	454	536	622	699	751	823	919	1.064	1.299	1.633	1.738

COLONNE

Tall units
Colonnes
Columnas
Hochschränke

H. 225

Colonna 4 ante

Tall unit 4-doors
Colonne 4 portes
Columna 4 puertas
4-türige Hochschrank

Apertura solo con maniglia

Opening with handle only
Ouverture seulement avec la poignée
Apertura sólo con tirador
Öffnung nur mit Griff

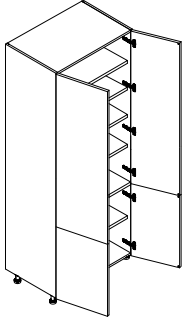

P/D	L/W	CODICE	0	1	2	3	4	5	6	7	8	9	10
34	90	KCN052250901	485	555	687	805	831	1.031	1.077	1.383	1.708	2.049	2.497
57	90	KCN052250904	540	620	750	865	892	1.094	1.139	1.477	1.826	2.321	2.571
67	90	KCN052250907	567	649	776	892	921	1.121	1.162	1.506	1.858	2.364	2.620

Colonna 2 ante + 3 cestoni interni

Tall unit 2 doors + 3 inner baskets
Colonne 2 portes + 3 paniers intérieurs
Columna 2 puertas + 3 cestas interiores
Hochschrank 2 Türen + 3 Innenschubkasten

Apertura con gola verticale o maniglia

Opening with vertical groove or handle
Ouverture avec rainure verticale ou poignée
Apertura con uñero vertical o tirador
Öffnung mit vertikaler Griffleiste

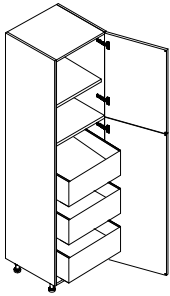

P/D	L/W	CODICE	0	1	2	3	4	5	6	7	8	9	10
57	45	KCK152250454	970	986	1.031	1.148	1.185	1.208	1.262	1.389	1.699	2.161	2.211
57	60	KCK152250604	1.012	1.036	1.107	1.235	1.283	1.324	1.404	1.558	1.907	2.425	2.475
57	75	KCK152250754	1.079	1.108	1.192	1.342	1.401	1.451	1.544	1.727	2.117	2.677	2.727
67	45	KCK152250457	1.073	1.088	1.132	1.249	1.288	1.310	1.365	1.493	1.827	2.322	2.372
67	60	KCK152250607	1.115	1.140	1.207	1.337	1.384	1.426	1.504	1.660	2.032	2.585	2.635
67	75	KCK152250757	1.181	1.211	1.292	1.443	1.503	1.552	1.645	1.828	2.243	2.837	2.887

Colonna 1 anta + 1 estraibile + 1 cestone interno

Tall unit 1 door + 1 pull-out + 1 inner basket
Colonne 1 porte + 1 extractible + 1 tiroirintérieur
Columna 1 puerta + 1 extraíble + 1 cajón interior
Hochschrank 1 Tür + 1 Auszug + 1 Innenschubkasten

Apertura con gola verticale o maniglia

Opening with vertical groove or handle
Ouverture avec rainure verticale ou poignée
Apertura con uñero vertical o tirador
Öffnung mit vertikaler Griffleiste

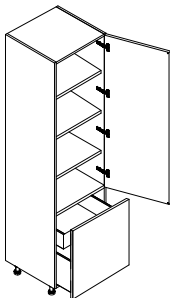

P/D	L/W	CODICE	0	1	2	3	4	5	6	7	8	9	10
57	45	KCN202250454	601	652	714	764	771	839	957	1.025	1.075	1.188	1.599
57	60	KCN202250604	677	728	812	862	900	968	1.151	1.219	1.259	1.438	1.892
57	75	KCN202250754	768	818	925	976	1.042	1.110	1.342	1.410	1.477	1.707	2.201
67	45	KCN202250457	652	701	764	814	822	889	1.008	1.076	1.127	1.239	1.651
67	60	KCN202250607	732	783	868	918	956	1.024	1.207	1.275	1.317	1.495	1.950
67	75	KCN202250757	828	879	986	1.037	1.103	1.171	1.403	1.471	1.540	1.770	2.264

Basi con maniglia
Base units with handle

Basi con gola
Base units with groove

Colonne
Tall units

Pensili
Wall units

Elementi speciali
Special elements

Maniglie gole zoccoli
Handles grooves plinth

Illuminazione
Lighting

Accessori
Accessories

Componenti e meccanismi
Components e mechanism

COLONNE

Tall units
Colonnes
Columnas
Hochschränke

H. 225

Colonna 1 anta + 4 cassetti

Tall unit 1 door + 4 drawers
Colonne 1 porte + 4 tiroirs
Columna 1 puerta + 4 cajones
Hochschrank 1 Tür + 4 Schubladen

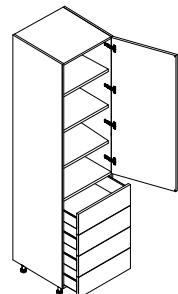

Apertura con gola verticale o maniglia
Opening with vertical groove or handle
Ouverture avec rainure verticale ou poignée
Apertura con uñero vertical o tirador
Öffnung mit vertikaler Griffleiste

P/D	L/W	CODICE	0	1	2	3	4	5	6	7	8	9	10
57	45	KCN242250454	657	707	804	854	897	965	1.087	1.155	1.352	1.476	1.864
57	60	KCN242250604	734	784	911	961	997	1.065	1.303	1.371	1.643	1.652	2.224
57	75	KCN242250754	814	864	1.020	1.071	1.113	1.180	1.527	1.595	1.832	1.860	2.587
67	45	KCN242250457	708	759	856	905	949	1.017	1.139	1.207	1.405	1.529	1.917
67	60	KCN242250607	792	842	969	1.019	1.055	1.123	1.361	1.429	1.703	1.712	2.284
67	75	KCN242250757	880	929	1.086	1.136	1.178	1.245	1.592	1.660	1.899	1.927	2.654

Colonna 1 anta + 2 cassetti + 1 cestone

Tall unit 1 door + 2 drawers + 1 basket
Colonne 1 porte + 2 tiroirs + 1 panier
Columna 1 puerta + 2 cajones + 1 cesta
Hochschrank 1 Tür + 2 Schubladen + 1 Schubkast

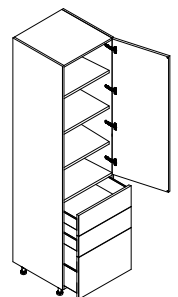

Apertura con gola verticale o maniglia
Opening with vertical groove or handle
Ouverture avec rainure verticale ou poignée
Apertura con uñero vertical o tirador
Öffnung mit vertikaler Griffleiste

P/D	L/W	CODICE	0	1	2	3	4	5	6	7	8	9	10
57	45	KCN232250454	609	660	745	794	815	883	1.009	1.077	1.274	1.308	1.746
57	60	KCN232250604	683	732	846	895	926	994	1.213	1.281	1.471	1.535	2.080
57	75	KCN232250754	760	810	951	1.000	1.050	1.117	1.425	1.493	1.639	1.757	2.418
67	45	KCN232250457	660	710	795	845	865	933	1.059	1.127	1.326	1.360	1.798
67	60	KCN232250607	739	789	902	952	983	1.051	1.270	1.338	1.529	1.593	2.138
67	75	KCN232250757	823	872	1.013	1.063	1.113	1.180	1.488	1.556	1.703	1.821	2.483

Colonna 1 anta + 2 cestoni

Tall unit 1 door + 2 baskets
Colonne 1 porte + 2 paniers
Columna 1 puerta + 2 cestas
Hochschrank 1 Tür + 2 Schubkasten

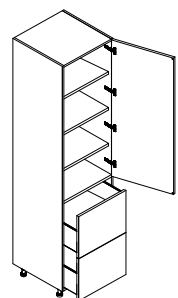

Apertura con gola verticale o maniglia
Opening with vertical groove or handle
Ouverture avec rainure verticale ou poignée
Apertura con uñero vertical o tirador
Öffnung mit vertikaler Griffleiste

P/D	L/W	CODICE	0	1	2	3	4	5	6	7	8	9	10
57	45	KCN222250454	562	612	686	736	732	800	930	998	1.140	1.196	1.628
57	60	KCN222250604	631	681	780	830	855	922	1.124	1.192	1.289	1.427	1.936
57	75	KCN222250754	706	756	880	930	987	1.055	1.324	1.392	1.446	1.654	2.250
67	45	KCN222250457	611	662	735	786	782	850	980	1.048	1.190	1.246	1.678
67	60	KCN222250607	686	735	834	885	910	978	1.179	1.246	1.346	1.484	1.992
67	75	KCN222250757	765	816	940	990	1.048	1.116	1.384	1.452	1.507	1.716	2.312

COLONNE

Tall units
Colonnes
Columnas
Hochschränke

H. 225

Colonna 1 anta + 2 cestoni

Tall unit 1 door + 2 baskets
Colonne 1 porte + 2 paniers
Columna 1 puerta + 2 cestas
Hochschrank 1 Tür + 2 Schubkasten

Apertura con gola orizzontale
Horizontal groove opening
Ouverture rainure horizontale
Apertura con uñero horizontal
Öffnung mit horizontaler Griffleiste

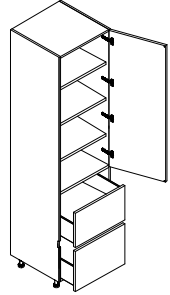

P/D	L/W	CODICE	0	1	2	3	4	5	6	7	8	9	10
57	45	KCG222250454	562	612	686	736	732	800	930	998	1.140	1.196	1.628
57	60	KCG222250604	631	681	780	830	855	922	1.124	1.192	1.289	1.427	1.936
57	75	KCG222250754	706	756	880	930	987	1.055	1.324	1.392	1.446	1.654	2.250
67	45	KCG222250457	611	662	735	786	782	850	980	1.048	1.190	1.246	1.678
67	60	KCG222250607	686	735	834	885	910	978	1.179	1.246	1.346	1.484	1.992
67	75	KCG222250757	765	816	940	990	1.048	1.116	1.384	1.452	1.507	1.716	2.312

Colonna 1 estraibile con meccanismo Linea Pro Sige

Tall unit 1 pull-out with mechanism Linea Pro Sige
Colonne 1 extractible avec mécanisme Linea Pro Sige
Columna 1 extraíble con mecanismo Linea Pro Sige
Hochschrank 1 Auszug mit Mechanismus Linea Pro Sige

Apertura con gola verticale o maniglia
Opening with vertical groove or handle
Ouverture avec rainure verticale ou poignée
Apertura con uñero vertical o tirador
Öffnung mit vertikaler Griffleiste

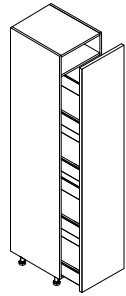

P/D	L/W	CODICE	0	1	2	3	4	5	6	7	8	9	10
57	30	KCN702250304	760	783	799	809	931	953	973	1.051	1.303	1.658	1.758
57	45	KCN702250454	834	853	870	996	1.020	1.051	1.070	1.227	1.519	1.932	2.032
67	30	KCN702250307	793	812	848	933	971	993	1.012	1.093	1.345	1.711	1.811
67	45	KCN702250457	870	889	906	1.034	1.061	1.090	1.110	1.273	1.571	1.996	2.096

Maggiorazione per meccanismo Linea Pure L. 30 Kessebohrer PUNTI 195

Mechanism Pure Line L. 30 Kessebohrer | Supplément pour le mécanisme Linea Pure L. 30 Kessebohrer | Recargo para mecanismo Linea Pure A.30 Kessebohrer | Aufpreis für Mechanismus Pure Line B. 30 Kessebohrer

Maggiorazione per meccanismo Linea Pure L. 45 Kessebohrer PUNTI 305

Mechanism Pure Line L. 45 Kessebohrer | Supplément pour le mécanisme Linea Pure L. 45 Kessebohrer | Recargo para mecanismo Linea Pure A.45 Kessebohrer | Aufpreis für Mechanismus Pure Line B. 45 Kessebohrer

Colonna 2 estraibili con meccanismo Linea Pro Sige

Tall unit 2 pull-outs with mechanism Linea Pro Sige
Colonne 2 extractibles avec mécanisme Linea Pro Sige
Columna 2 extraíbles con mecanismo Linea Pro Sige
Hochschrank 2 Auszüge mit Mechanismus Linea Pro Sige

Apertura con gola verticale o maniglia
Opening with vertical groove or handle
Ouverture avec rainure verticale ou poignée
Apertura con uñero vertical o tirador
Öffnung mit vertikaler Griffleiste

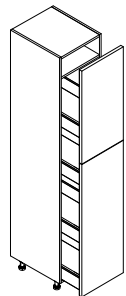

P/D	L/W	CODICE	0	1	2	3	4	5	6	7	8	9	10
57	30	KCN722250304	772	839	867	936	983	1.011	1.048	1.185	1.467	1.865	1.965
57	45	KCN722250454	818	902	955	1.051	1.102	1.139	1.184	1.367	1.692	2.153	2.253
67	30	KCN722250307	791	858	886	954	1.003	1.029	1.065	1.205	1.491	1.896	1.996
67	45	KCN722250457	835	920	977	1.070	1.121	1.156	1.204	1.386	1.712	2.180	2.280

Maggiorazione per meccanismo Linea Pure L. 30 Kessebohrer PUNTI 195

Mechanism Pure Line L. 30 Kessebohrer | Supplément pour le mécanisme Linea Pure L. 30 Kessebohrer | Recargo para mecanismo Linea Pure A.30 Kessebohrer | Aufpreis für Mechanismus Pure Line B. 30 Kessebohrer

Maggiorazione per meccanismo Linea Pure L. 45 Kessebohrer PUNTI 305

Mechanism Pure Line L. 45 Kessebohrer | Supplément pour le mécanisme Linea Pure L. 45 Kessebohrer | Recargo para mecanismo Linea Pure A.45 Kessebohrer | Aufpreis für Mechanismus Pure Line B. 45 Kessebohrer

Basi con maniglia
Base units with handle

Basi con gola
Base units with groove

Colonne
Tall units

Pensili
Wall units

Elementi speciali
Special elements

Maniglie gole zoccoli
Handles grooves plinth

Illuminazione
Lighting

Accessori
Accessories

Componenti e meccanismi
Components e mechanism

COLONNE

Tall units
Colonnes
Columnas
Hochschränke

H. 225

Colonna 2 estraibili con meccanismo Linea Pro Sige

Tall unit 2 pull-outs with mechanism Linea Pro Sige
Colonne 2 extractibles avec mécanisme Linea Pro Sige
Columna 2 extraíbles con mecanismo Linea Pro Sige
Hochschrank 2 Auszüge mit Mechanismus Linea Pro Sige

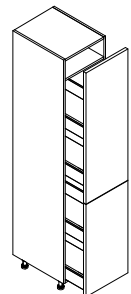

Apertura con gola verticale o maniglia
Opening with vertical groove or handle
Ouverture avec rainure verticale ou poignée
Apertura con uñero vertical o tirador
Öffnung mit vertikaler Griffleiste

P/D	L/W	CODICE	0	1	2	3	4	5	6	7	8	9	10
57	30	KCN712250304	772	839	867	936	983	1.011	1.048	1.185	1.467	1.865	1.965
57	45	KCN712250454	818	902	955	1.051	1.102	1.139	1.184	1.367	1.692	2.153	2.253
67	30	KCN712250307	791	858	886	954	1.003	1.029	1.065	1.205	1.491	1.896	1.996
67	45	KCN712250457	835	920	977	1.070	1.121	1.156	1.204	1.386	1.712	2.180	2.280

Maggiorazione per meccanismo Linea Pure L. 30 Kessebohmer PUNTI 195

Mechanism Pure Line L. 30 Kessebohmer | Supplément pour le mécanisme Linea Pure L. 30 Kessebohmer | Recargo para mecanismo Linea Pure A.30 Kessebohmer | Aufpreis für Mechanismus Pure Line B. 30 Kessebohmer

Maggiorazione per meccanismo Linea Pure L. 45 Kessebohmer PUNTI 305

Mechanism Pure Line L. 45 Kessebohmer | Supplément pour le mécanisme Linea Pure L. 45 Kessebohmer | Recargo para mecanismo Linea Pure A.45 Kessebohmer | Aufpreis für Mechanismus Pure Line B. 45 Kessebohmer

Colonna 1 anta con meccanismo Linea Pro Sige

Tall unit 1 door with mechanism Linea Pro Sige
Colonne 1 porte avec mécanisme Linea Pro Sige
Columna 1 puerta con mecanismo Linea Pro Sige
Hochschrank 1 Tür mit Mechanismus Linea Pro Sige

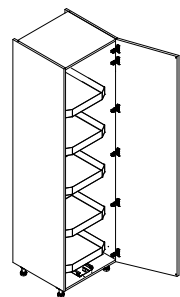

Apertura con gola verticale o maniglia
Opening with vertical groove or handle
Ouverture avec rainure verticale ou poignée
Apertura con uñero vertical o tirador
Öffnung mit vertikaler Griffleiste

P/D	L/W	CODICE	0	1	2	3	4	5	6	7	8	9	10
57	60	KCN752250604	1.342	1.359	1.433	1.562	1.612	1.654	1.730	1.873	2.118	2.693	2.793
67	60	KCN752250607	136	1.380	1.451	1.580	1.631	1.672	1.749	1.892	2.143	2.725	2.825

Maggiorazione per meccanismo Arena Style Kessebohmer PUNTI 857

Arena Style Kessebohmer mechanism | Supplément pour le mécanisme Arena Style Kessebohmer | Recargo para mecanismo Arena Style Kessebohmer | Aufpreis für Arena Style Kessebohmer Mechanismus

Colonna 1 anta con meccanismo Linea Pro Sige

Tall unit 1 door with mechanism Linea Pro Sige
Colonne 1 porte avec mécanisme Linea Pro Sige
Columna 1 puerta con mecanismo Linea Pro Sige
Hochschrank 1 Tür mit Mechanismus Linea Pro Sige

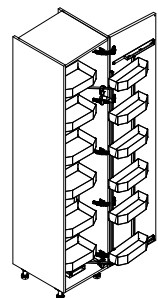

Apertura con gola verticale o maniglia
Opening with vertical groove or handle
Ouverture avec rainure verticale ou poignée
Apertura con uñero vertical o tirador
Öffnung mit vertikaler Griffleiste

P/D	L/W	CODICE	0	1	2	3	4	5	6	7	8	9	10
57	45	KCN742250454	1.131	1.245	1.276	1.365	1.408	1.449	1.491	1.634	2.022	2.571	2.671
57	60	KCN742250604	1.205	1.332	1.353	1.493	1.529	1.559	1.696	1.846	2.284	2.905	3.005
67	45	KCN742250457	1.150	1.267	1.296	1.383	1.426	1.469	1.508	1.653	2.044	2.599	2.699
67	60	KCN742250607	1.224	1.349	1.374	1.510	1.547	1.577	1.714	1.863	2.308	2.936	3.036

Maggiorazione per meccanismo Linea Pure L. 45 Kessebohmer PUNTI 438

Mechanism Pure Line L. 45 Kessebohmer | Supplément pour le mécanisme Linea Pure L. 45 Kessebohmer | Recargo para mecanismo Linea Pure A.45 Kessebohmer | Aufpreis für Mechanismus Pure Line B. 45 Kessebohmer

Maggiorazione per meccanismo Linea Pure L. 60 Kessebohmer PUNTI 657

Mechanism Pure Line L. 60 Kessebohmer | Supplément pour le mécanisme Linea Pure L. 60 Kessebohmer | Recargo para mecanismo Linea Pure A.60 Kessebohmer | Aufpreis für Mechanismus Pure Line L. 60 Kessebohmer

COLONNE

Tall units
Colonnes
Columnas
Hochschränke

H. 225

Colonna 1 anta portascopie

Tall unit 1-door broom
Colonne 1 porte pour balai
Columna 1 puerta para escobas
Hochschrank 1 Tür Besenstiel

Apertura con gola verticale o maniglia
Opening with vertical groove or handle
Ouverture avec rainure verticale ou poignée
Apertura con uñero vertical o tirador
Öffnung mit vertikaler Griffleiste

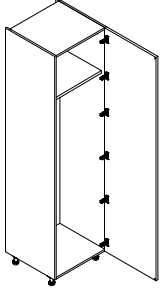

P/D	L/W	CODICE	0	1	2	3	4	5	6	7	8	9	10
57	45	KCN072250454	457	538	612	705	758	848	901	1.050	1.283	1.632	1.682
57	60	KCN072250604	549	649	742	873	931	1.016	1.132	1.310	1.607	2.043	2.093
67	45	KCN072250457	478	562	637	728	776	868	922	1.073	1.310	1.665	1.715
67	60	KCN072250607	569	672	766	894	955	1.040	1.156	1.333	1.633	2.076	2.116

Colonna 1 anta lavatrice - asciugatrice

Tall unit 1 door washer-dryer
Colonne 1 porte lave-linge- sèche-linge
Columna 1 puerta lavadora-secadora
Hochschrank 1 Tür Waschmaschine - Trockner

Apertura con gola verticale o maniglia
Opening with vertical groove or handle
Ouverture avec rainure verticale ou poignée
Apertura con uñero vertical o tirador
Öffnung mit vertikaler Griffleiste

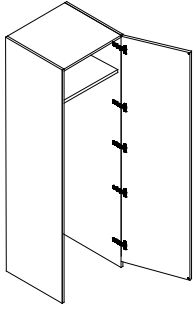

P/D	L/W	CODICE	0	1	2	3	4	5	6	7	8	9	10
67	69	KCN082250697	384	449	529	635	684	756	853	999	1.238	1.485	1.535

Colonna 2 ante lavatrice - asciugatrice

Tall unit 2 door washer-dryer
Colonne 2 portes lave-linge- sèche-linge
Columna 2 puertas lavadora-secadora
2-türige Waschmaschinen-Trockner-Hochschrank

Apertura con gola verticale o maniglia
Opening with vertical groove or handle
Ouverture avec rainure verticale ou poignée
Apertura con uñero vertical o tirador
Öffnung mit vertikaler Griffleiste

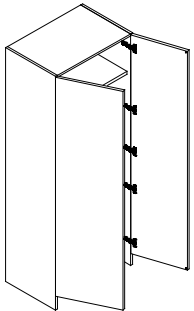

P/D	L/W	CODICE	0	1	2	3	4	5	6	7	8	9	10
67	90	KCN092250907	452	517	597	703	752	824	921	1.067	1.308	1.555	1.605

Basi con maniglia
Base units with handle

Basi con gola
Base units with groove

Colonne
Tall units

Pensili
Wall units

Elementi speciali
Special elements

Maniglie gole zoccoli
Handles grooves plinth

Illuminazione
Lighting

Accessori
Accessories

Componenti e meccanismi
Components e mechanism

COLONNE

Tall units
Colonnes
Columnas
Hochschränke

H. 225

Colonna angolo 1 anta
Corner tall unit 1 door
Colonne d'angle 1 porte
Columna ángulo 1 puerta
Eckehochschrank 1 Tür

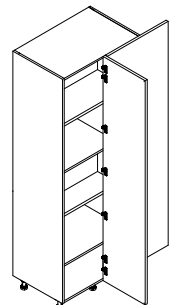

Apertura con gola verticale o maniglia
Opening with vertical groove or handle
Ouverture avec rainure verticale ou poignée
Apertura con uñero vertical o tirador
Öffnung mit vertikaler Griffleiste

	P/D	L/W	CODICE	0	1	2	3	4	5	6	7	8	9	10
●	59,5	110	KCA012251104D/S	870	904	982	1.137	1.219	1.367	1.440	1.708	2.109	2.682	2.782
△	59,5	120	KCA012251204D/S	902	934	1.030	1.213	1.307	1.447	1.376	1.862	2.300	2.925	3.025
●	69,5	110	KCA012251107D/S	884	915	991	1.145	1.228	1.374	137	1.713	2.115	2.691	2.791
△	69,5	120	KCA012251207D/S	914	946	1.041	1.218	1.314	1.452	1.574	1.862	2.300	2.927	3.027

- **scocca da 75 cm** | 75 cm body | structure de 75 cm | estructura de 75 cm | 75 cm Korpus
- △ **scocca da 120 cm** | 120 cm body | structure de 120 cm | estructura de 120 cm | 120 cm Korpus

Colonna angolo 2 ante
Corner tall unit 2 doors
Colonne d'angle 2 portes
Columna ángulo 2 puertas
Eckehochschrank 2 Türen

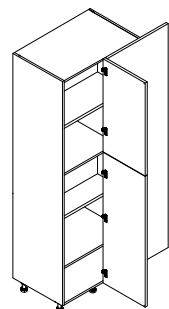

Apertura con gola verticale o maniglia
Opening with vertical groove or handle
Ouverture avec rainure verticale ou poignée
Apertura con uñero vertical o tirador
Öffnung mit vertikaler Griffleiste

	P/D	L/W	CODICE	0	1	2	3	4	5	6	7	8	9	10
●	59,5	110	KCA042251104D/S	870	904	982	1.137	1.219	1.367	1.440	1.708	2.109	2.682	2.782
△	59,5	120	KCA042251204D/S	902	934	1.030	1.213	1.307	1.447	1.376	1.862	2.300	2.925	3.025
●	69,5	110	KCA042251107D/S	884	915	991	1.145	1.228	1.374	137	1.713	2.115	2.691	2.791
△	69,5	120	KCA042251207D/S	914	946	1.041	1.218	1.314	1.452	1.574	1.862	2.300	2.927	3.027

- **scocca da 75 cm** | 75 cm body | structure de 75 cm | estructura de 75 cm | 75 cm Korpus
- △ **scocca da 120 cm** | 120 cm body | structure de 120 cm | estructura de 120 cm | 120 cm Korpus

Colonna angolo 2 ante
Corner tall unit 2 doors
Colonne d'angle 2 portes
Columna ángulo 2 puertas
Eckehochschrank 2 Türen

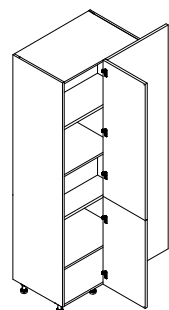

Apertura con gola verticale o maniglia
Opening with vertical groove or handle
Ouverture avec rainure verticale ou poignée
Apertura con uñero vertical o tirador
Öffnung mit vertikaler Griffleiste

	P/D	L/W	CODICE	0	1	2	3	4	5	6	7	8	9	10
●	59,5	110	KCA032251104D/S	870	904	982	1.137	1.219	1.367	1.440	1.708	2.109	2.682	2.782
△	59,5	120	KCA032251204D/S	902	934	1.030	1.213	1.307	1.447	1.376	1.862	2.300	2.925	3.025
●	69,5	110	KCA032251107D/S	884	915	991	1.145	1.228	1.374	137	1.713	2.115	2.691	2.791
△	69,5	120	KCA032251207D/S	914	946	1.041	1.218	1.314	1.452	1.574	1.862	2.300	2.927	3.027

- **scocca da 75 cm** | 75 cm body | structure de 75 cm | estructura de 75 cm | 75 cm Korpus
- △ **scocca da 120 cm** | 120 cm body | structure de 120 cm | estructura de 120 cm | 120 cm Korpus

COLONNE

Tall units
Colonnes
Columns
Hochschränke

H. 225

Colonna angolo 1 anta con meccanismo Linea Pro Sige

Corner tall unit 1 door with mechanism Linea Pro Sige
Colonne d'angle 1 porte avec mécanisme Linea Pro Sige
Columna ángulo 1 puerta con mecanismo Linea Pro Sige
Eckehochschrank 1 Tür mit Mechanismus Linea Pro Sige

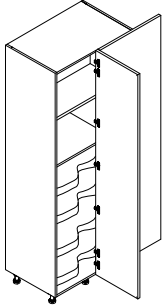

P/D	L/W	CODICE	0	1	2	3	4	5	6	7	8	9	10
○ 59,5	110	KCA762251104D/S	1.686	1.712	1.762	2.003	2.088	2.177	2.325	2.523	2.939	3.736	3.836
▲ 59,5	125	KCA762251254D/S	1.830	1.860	1.939	2.192	2.285	2.397	2.571	2.792	3.248	4.130	4.230
○ 69,5	120	KCA762251207D/S	1.720	1.746	1.797	2.043	2.128	2.219	2.374	2.571	2.998	3.915	4.015
▲ 69,5	135	KCA762251357D/S	1.866	1.896	1.979	2.237	2.330	2.443	2.627	2.846	3.312	4.325	4.425

- **scocca da 90 cm** | 90 cm body | structure de 90 cm | estructura de 90 cm | 90 cm Korpus
- ▲ **scocca da 105 cm** | 105 cm body | structure de 105 cm | estructura de 105 cm | 105 cm Korpus

Maggiorazione per meccanismo Linea Pure Kessebohmer PUNTI 645

Mechanism Pure Kessebohmer Line | Supplément pour le mécanisme Linea Pure Kessebohmer | Recargo para mecanismo Linea Pure Kessebohmer | Aufpreis für Mechanismus Pure Kessebohmer Line

Colonna angolo 2 ante con meccanismo Linea Pro Sige

Corner tall unit 2 doors with mechanism Linea Pro Sige
Colonne d'angle 2 portes avec mécanisme Linea Pro Sige
Columna ángulo 2 puertas con mecanismo Linea Pro Sige
2-türige Eckehochschrank mit Mechanismus Linea Pro Sige

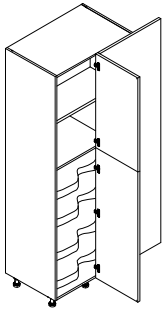

P/D	L/W	CODICE	0	1	2	3	4	5	6	7	8	9	10
○ 59,5	110	KCA782251104D/S	1.686	1.712	1.762	2.003	2.088	2.177	2.325	2.523	2.939	3.736	3.836
▲ 59,5	125	KCA782251254D/S	1.830	1.860	1.939	2.192	2.285	2.397	2.571	2.792	3.248	4.130	4.230
○ 69,5	120	KCA782251207D/S	1.720	1.746	1.797	2.043	2.128	2.219	2.374	2.571	2.998	3.915	4.015
▲ 69,5	135	KCA782251357D/S	1.866	1.896	1.979	2.237	2.330	2.443	2.627	2.846	3.312	4.325	4.425

- **scocca da 90 cm** | 90 cm body | structure de 90 cm | estructura de 90 cm | 90 cm Korpus
- ▲ **scocca da 105 cm** | 105 cm body | structure de 105 cm | estructura de 105 cm | 105 cm Korpus

Maggiorazione per meccanismo Linea Pure Kessebohmer PUNTI 645

Mechanism Pure Kessebohmer Line | Supplément pour le mécanisme Linea Pure Kessebohmer | Recargo para mecanismo Linea Pure Kessebohmer | Aufpreis für Mechanismus Pure Kessebohmer Line

Colonna angolo 2 ante con meccanismo Linea Pro Sige

Corner tall unit 2 doors with mechanism Linea Pro Sige
Colonne d'angle 2 portes avec mécanisme Linea Pro Sige
Columna ángulo 2 puertas con mecanismo Linea Pro Sige
2-türige Eckehochschrank mit Mechanismus Linea Pro Sige

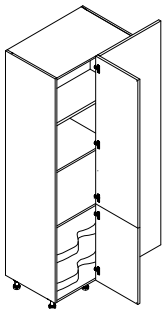

P/D	L/W	CODICE	0	1	2	3	4	5	6	7	8	9	10
○ 59,5	110	KCA772251104D/S	1.327	1.359	1.434	1.634	1.718	1.865	1.938	2.207	2.622	3.335	3.435
▲ 59,5	125	KCA772251254D/S	1.422	1.452	1.543	1.776	1.869	2.011	2.133	2.425	2.881	3.664	3.764
○ 69,5	120	KCA772251207D/S	1.365	1.398	1.472	1.678	1.764	1.915	1.989	2.264	2.694	3.426	3.526
▲ 69,5	135	KCA772251357D/S	1.461	1.492	1.581	1.820	1.918	2.059	2.185	2.483	2.952	3.756	3.856

- **scocca da 90 cm** | 90 cm body | structure de 90 cm | estructura de 90 cm | 90 cm Korpus
- ▲ **scocca da 105 cm** | 105 cm body | structure de 105 cm | estructura de 105 cm | 105 cm Korpus

Maggiorazione per meccanismo Linea Pure Kessebohmer PUNTI 269

Mechanism Pure Kessebohmer Line | Supplément pour le mécanisme Linea Pure Kessebohmer | Recargo para mecanismo Linea Pure Kessebohmer | Aufpreis für Mechanismus Pure Kessebohmer Line

Basi con maniglia
Base units with handle

Basi con gola
Base units with groove

Colonnes
Tall units

Pensili
Wall units

Elementi speciali
Special elements

Maniglie gole zoccoli
Handles grooves plinth

Illuminazione
Lighting

Accessori
Accessories

Componenti e meccanismi
Components e mechanism

COLONNE

H. 225

Tall units
Colonne
Columnas
Hochschranke

Cabina angolo 1 anta

Corner pantry 1 door
Dressing d'angle 1 porte
Cabina ángulo 1 puerta
Eckkabine 1 Tür

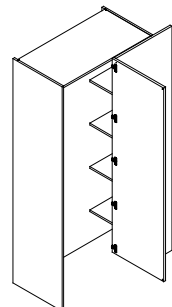

Apertura con gola verticale o maniglia
Opening with vertical groove or handle
Ouverture avec rainure verticale ou poignée
Apertura con uñero vertical o tirador
Öffnung mit vertikaler Griffleiste

P/D	L/W	CODICE	0	1	2	3	4	5	6	7	8	9	10
80	150	KCB012251508D/S	2.030	2.139	2.247	2.571	2.788	2.949	3.165	3.490	4.100	4.546	4.946

Colonna 1 anta copriboiler

Tall unit 1 door for water header / boiler
Colonne 1 porte pour cumulus
Columna 1 puerta para cubrir un boiler
Abdeckung der Wasser-warme

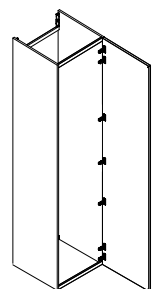

Apertura con gola verticale o maniglia
Opening with vertical groove or handle
Ouverture avec rainure verticale ou poignée
Apertura con uñero vertical o tirador
Öffnung mit vertikaler Griffleiste

P/D	L/W	CODICE	0	1	2	3	4	5	6	7	8	9	10
57	60	KCD012250604	469	498	536	599	609	655	702	796	933	1.107	1.157
67	60	KCD012250607	481	509	548	611	621	666	714	808	945	1.119	1.169

COLONNE FORNO

Oven tall units
Colonnes four
Columnas horno
Backofen-Hochschranke

H. 225

Colonna forno 2 ante (frontale superiore su misura)

Oven tall unit 2 doors (upper front made to measure)
Colonne four 2 portes (façade supérieure sur mesure)
Columna horno 2 puertas (frontal superior a medida)
Backofenschrank 2 Türen (obere Front nach Maß)

Apertura con gola verticale o maniglia
Opening with vertical groove or handle
Ouverture avec rainure verticale ou poignée
Apertura con uñero vertical o tirador
Öffnung mit vertikaler Griffleiste

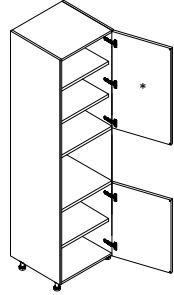

P/D	L/W	CODICE	0	1	2	3	4	5	6	7	8	9	10
57	60	KCP022250604	415	491	514	601	643	695	754	873	1.063	1.276	1.388
67	60	KCP022250607	437	510	534	621	661	715	768	892	1.087	1.304	1.427

* Frontale su misura | Customised front panel | Façade sur mesure | Frente medida especial | Fronten in Sondermasse

Colonna forno 2 ante

Oven tall unit 2 doors
Colonne four 2 portes
Columna horno 2 puertas
Backofenschrank 2 Türen

Apertura con gola verticale o maniglia
Opening with vertical groove or handle
Ouverture avec rainure verticale ou poignée
Apertura con uñero vertical o tirador
Öffnung mit vertikaler Griffleiste

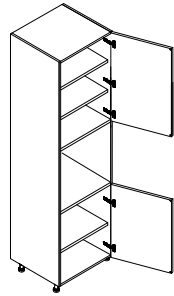

P/D	L/W	CODICE	0	1	2	3	4	5	6	7	8	9	10
57	60	KC0022250604	329	382	432	517	560	611	669	790	977	1.174	1.310
57	75	KC0022250754	381	444	500	601	648	708	775	916	1.133	1.360	1.541
67	60	KC0022250607	347	402	449	536	577	631	686	807	1.000	1.201	1.349
67	75	KC0022250757	404	466	521	622	669	731	793	936	1.159	1.392	1.584

□ forno L 75 cm | oven L 75 cm | four L 75 cm | horno L 75 cm | backofen B 75 cm

Colonna forno 1 anta + 1 estraibile + 1 cestone interno

Oven tall unit 1 door + 1 drawer + 1 inner basket
Colonne four 1 porte + 1 extractible + 1 tiroir intérieur
Columna horno 1 puerta + 1 cajón + 1 cajón interior
Backofenschrank 1 Tür + 1 Schublade + 1 Innenschubkast

Apertura con gola verticale o maniglia
Opening with vertical groove or handle
Ouverture avec rainure verticale ou poignée
Apertura con uñero vertical o tirador
Öffnung mit vertikaler Griffleiste

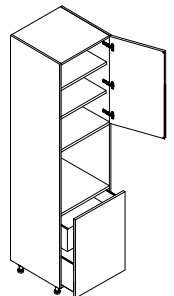

P/D	L/W	CODICE	0	1	2	3	4	5	6	7	8	9	10
57	60	KC0202250604	518	590	637	725	764	819	873	996	1.191	1.429	1.579
57	75	KC0202250754	634	683	739	840	886	949	1.012	1.153	1.379	1.655	1.832
67	60	KC0202250607	621	691	739	826	866	921	976	1.098	1.299	1.558	1.637
67	75	KC0202250757	758	800	857	957	1.004	1.067	1.130	1.272	1.505	1.805	1.895

□ forno L 75 cm | oven L 75 cm | four L 75 cm | horno L 75 cm | backofen B 75 cm

Basi con maniglia
Base units with handle

Basi con gola
Base units with groove

Colonne
Tall units

Pensili
Wall units

Elementi speciali
Special elements

Maniglie gole zoccoli
Handles grooves plinth

Illuminazione
Lighting

Accessori
Accessories

Componenti e meccanismi
Components e mechanism

COLONNE FORNO

H. 225

Oven tall units
Colonnes four
Columnas horno
Backofen-Hochschranke

Colonna forno 1 anta + 1 estraibile + 2 cassetti interni

Oven tall unit 1 door + 1 pull-out + 2 internal drawers
Colonne four 1 porte + 1 extractible + 2 tiroirs intérieurs
Columna horno 1 puerta + 1 extraíble + 2 cajones interiores
Backofenschrank 1 Tür + 1 Auszug + 2 Innenschubladen

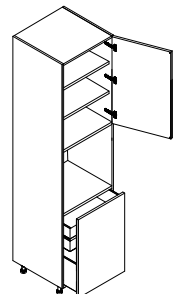

Apertura con gola verticale o maniglia
Opening with vertical groove or handle
Ouverture avec rainure verticale ou poignée
Apertura con uñero vertical o tirador
Öffnung mit vertikaler Griffleiste

P/D	L/W	CODICE	0	1	2	3	4	5	6	7	8	9	10
57	60	KC0212250604	586	658	705	792	832	887	941	1.064	1.261	1.499	1.649
57	75	KC0212250754	702	751	807	908	954	1.017	1.080	1.221	1.449	1.725	1.902
67	60	KC0212250607	689	759	807	894	934	988	1.044	1.166	1.369	1.628	1.707
67	75	KC0212250757	825	868	925	1.025	1.072	1.135	1.198	1.340	1.575	1.875	1.965

□ forno L 75 cm | oven L 75 cm | four L 75 cm | horno L 75 cm | backofen B 75 cm

Colonna forno 1 anta + 4 cassetti

Oven tall unit 1 door + 4 drawers
Colonne four 1 porte + 4 tiroirs
Columna horno 1 puerta + 4 cajones
Backofenschrank 1 Tür + 4 Schubladen

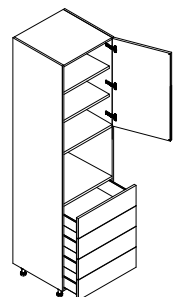

Apertura con gola verticale o maniglia
Opening with vertical groove or handle
Ouverture avec rainure verticale ou poignée
Apertura con uñero vertical o tirador
Öffnung mit vertikaler Griffleiste

P/D	L/W	CODICE	0	1	2	3	4	5	6	7	8	9	10
57	60	KC0242250604	630	736	783	902	955	986	1.080	1.210	1.495	1.794	1.911
57	75	KC0242250754	807	916	963	1.082	1.139	1.167	1.259	1.388	1.721	2.064	2.218
67	60	KC0242250607	697	804	851	970	1.023	1.053	1.148	1.277	1.565	1.864	1.981
67	75	KC0242250757	875	984	1.031	1.149	1.207	1.235	1.327	1.456	1.791	2.134	2.288

□ forno L 75 cm | oven L 75 cm | four L 75 cm | horno L 75 cm | backofen B 75 cm

Colonna forno 1 anta + 2 cassetti + 1 cestone

Oven tall unit 1 door + 2 drawers + 1 drawer
Colonne four 1 porte + 2 tiroirs + 1 tiroir
Columna horno 1 puerta + 2 cajones + 1 cajón
Backofenschrank 1 Tür + 2 Schubladen + 1 Schublade

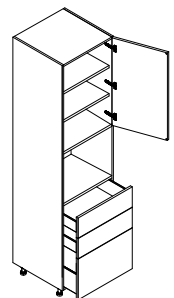

Apertura con gola verticale o maniglia
Opening with vertical groove or handle
Ouverture avec rainure verticale ou poignée
Apertura con uñero vertical o tirador
Öffnung mit vertikaler Griffleiste

P/D	L/W	CODICE	0	1	2	3	4	5	6	7	8	9	10
57	60	KC0232250604	578	678	726	832	887	926	982	1.132	1.397	1.676	1.716
57	75	KC0232250754	706	786	841	964	1.027	1.074	1.139	1.311	1.619	1.941	1.991
67	60	KC0232250607	723	823	867	976	1.029	1.070	1.124	1.276	1.574	1.888	1.938
67	75	KC0232250757	880	953	1.005	1.130	1.193	1.238	1.303	1.477	1.823	2.187	2.237

□ forno L 75 cm | oven L 75 cm | four L 75 cm | horno L 75 cm | backofen B 75 cm

COLONNE FORNO

H. 225

Oven tall units
Colonnes four
Columnas horno
Backofen-Hochschranke

Colonna forno 1 anta + 2 cestoni

Oven tall unit 1 door + 2 baskets
Colonne four 1 porte + 2 paniers
Columna horno 1 puerta + 2 cestas
Backofenschrank 1 Tür + 2 Schubkasten

Apertura con gola verticale o maniglia
Opening with vertical groove or handle
Ouverture avec rainure verticale ou poignée
Apertura con uñero vertical o tirador
Öffnung mit vertikaler Griffleiste

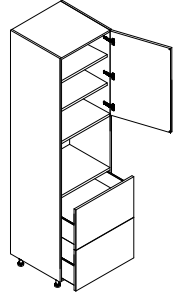

P/D	L/W	CODICE	0	1	2	3	4	5	6	7	8	9	10
57	60	KC0222250604	532	622	666	765	814	862	903	1.057	1.298	1.556	1.623
57	75	KC0222250754	647	722	773	887	943	999	1.048	1.226	1.504	1.803	1.881
67	60	KC0222250607	636	727	772	870	919	968	1.007	1.161	1.429	1.714	1.679
67	75	KC0222250757	775	843	895	1.010	1.064	1.121	1.167	1.346	1.655	1.986	2.036

forno L 75 cm | oven L 75 cm | four L 75 cm | horno L 75 cm | backofen B 75 cm

Colonna forno 1 anta + 2 cestoni

Oven tall unit 1 door + 2 baskets
Colonne four 1 porte + 2 paniers
Columna horno 1 puerta + 2 cestas
Backofenschrank 1 Tür + 2 Schubkasten

Apertura con gola orizzontale
Horizontal groove opening
Ouverture rainure horizontale
Apertura con uñero horizontal
Öffnung mit horizontaler Griffleiste

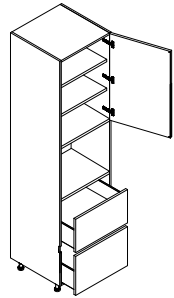

P/D	L/W	CODICE	0	1	2	3	4	5	6	7	8	9	10
57	60	KCH222250604	532	622	666	765	814	862	903	1.057	1.298	1.556	1.623
57	75	KCH222250754	647	722	773	887	943	999	1.048	1.226	1.504	1.803	1.881
67	60	KCH222250607	636	727	772	870	919	968	1.007	1.161	1.429	1.714	1.679
67	75	KCH222250757	775	843	895	1.010	1.064	1.121	1.167	1.346	1.655	1.986	2.036

forno L 75 cm | oven L 75 cm | four L 75 cm | horno L 75 cm | backofen B 75 cm

Colonna forno + microonde 1 anta + 1 cestone

Tall unit oven + microwave 1 door + 1 drawer
Colonne four + micro 1 porte + 1 panier
Columna horno + microondas 1 puerta + 1 cajón
Schrankofen + Mikrowelle 1 Tür + 1 Schublade

Apertura con gola verticale o maniglia
Opening with vertical groove or handle
Ouverture avec rainure verticale ou poignée
Apertura con uñero vertical o tirador
Öffnung mit vertikaler Griffleiste

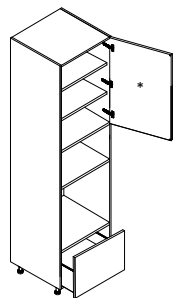

P/D	L/W	CODICE	0	1	2	3	4	5	6	7	8	9	10
57	60	KCM272250604	463	549	597	692	739	791	830	985	1.211	1.452	1.502
67	60	KCM272250607	524	611	657	756	801	853	891	1.048	1.285	1.544	1.594

* Frontale su misura | Customised front panel | Façade sur mesure | Frente medida especial | Fronten in Sondermasse

Basi con maniglia
Base units with handle

Basi con gola
Base units with groove

Colonne
Tall units

Pensili
Wall units

Elementi speciali
Special elements

Maniglie gole zoccoli
Handles grooves plinth

Illuminazione
Lighting

Accessori
Accessories

Componenti e meccanismi
Components e mechanism

COLONNE FORNO

Oven tall units
Colonnes four
Columnas horno
Backofen-Hochschränke

H. 225

Colonna forno + cantinetta 1 anta + 1 frontale fisso

Tall unit oven + wine cellar 1 door + 1 fixed front
Colonne four + cave à vin 1 porte + 1 façade fixe
Columna para horno+ espacio para vinos + 1 frente fijo
Schrankofen + Weinkeller 1 Tür + 1 feste Front

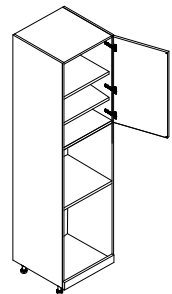

Apertura con gola verticale o maniglia
Opening with vertical groove or handle
Ouverture avec rainure verticale ou poignée
Apertura con uñero vertical o tirador
Öffnung mit vertikaler Griffleiste

P/D	L/W	CODICE	0	1	2	3	4	5	6	7	8	9	10
57	60	KCQ312250604	321	372	413	491	527	572	623	732	903	1.083	1.133
57	60	KCQ312250607	340	391	431	510	544	593	639	750	925	1.110	1.160

Colonna forno + microonde 2 ante

Oven tall unit + microwave 2 doors
Colonne four+ micro 2 portes
Horno columna + microondas 2 puertas
Schrankofen + Mikrowelle 2 Türen

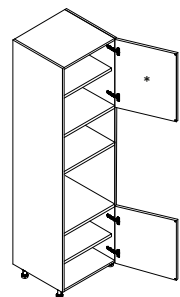

Apertura con gola verticale o maniglia
Opening with vertical groove or handle
Ouverture avec rainure verticale ou poignée
Apertura con uñero vertical o tirador
Öffnung mit vertikaler Griffleiste

P/D	L/W	CODICE	0	1	2	3	4	5	6	7	8	9	10
57	60	KCM022250604	349	424	493	594	611	645	694	792	965	1.153	1.203
67	60	KCM022250607	372	444	512	613	631	665	695	797	974	1.167	1.217

* **Frontale su misura** | Customised front panel | Façade sur mesure | Frente medida especial | Fronten in Sondermasse

Colonna forno + microonde 1 anta + 1 cassetto + 1 cestone

Tall unit oven + microwave 1 door + 1 drawer + 1 drawer
Colonne four + micro 1 porte + 1 tiroir + 1 panier
Columna horno + microondas 1 puerta + 1 cajón + 1 cajón
Schrankofen + Mikrowelle 1 Tür + 1 Schublade + 1 Schublade

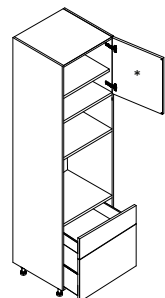

Apertura con gola verticale o maniglia
Opening with vertical groove or handle
Ouverture avec rainure verticale ou poignée
Apertura con uñero vertical o tirador
Öffnung mit vertikaler Griffleiste

P/D	L/W	CODICE	0	1	2	3	4	5	6	7	8	9	10
57	60	KCM282250604	538	630	677	773	821	873	911	1.065	1.311	1.573	1.623
67	60	KCM282250607	642	732	780	876	922	976	1.013	1.169	1.434	1.723	1.773

* **Frontale su misura** | Customised front panel | Façade sur mesure | Frente medida especial | Fronten in Sondermasse

COLONNE FORNO

Oven tall units
Colonnes four
Columnas horno
Backofen-Hochschranke

H. 225

Colonna forno + microonde 1 anta + 1 cassetto + 1 cestone

Tall unit oven + microwave 1 door + 1 drawer + 1 drawer
Colonne four + micro 1 porte + 1 tiroir + 1 panier
Columna horno + microondas 1 puerta + 1 cajón + 1 cajón
Schrankofen + Mikrowelle 1 Tür + 1 Schublade + 1 Schublade

Apertura con gola orizzontale
Horizontal groove opening
Ouverture rainure horizontale
Apertura con uñero horizontal
Öffnung mit horizontaler Griffleiste

P/D	L/W	CODICE	0	1	2	3	4	5	6	7	8	9	10
57	60	KCI282250604	538	630	677	773	821	873	911	1.065	1.311	1.573	1.623
67	60	KCI282250607	642	732	780	876	922	976	1.013	1.169	1.434	1.723	1.773

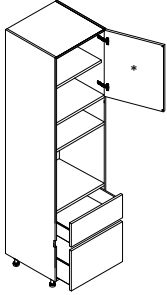

* Frontale su misura | Customised front panel | Façade sur mesure | Frente medida especial | Fronten in Sondermasse

Colonna forno sospesa 1 anta (sopra lavastoviglie)

Suspended oven tall unit 1 door (above dishwasher)
Colonne four suspendue 1 porte (au-dessus du lave-vaisselle)
Columna horno suspendida 1 puerta (sobre lavavajillas)
Haenge Backofenschrank 1 Tür (über Geschirrspüler)

Apertura con gola verticale o maniglia
Opening with vertical groove or handle
Ouverture avec rainure verticale ou poignée
Apertura con uñero vertical o tirador
Öffnung mit vertikaler Griffleiste

P/D	L/W	CODICE	0	1	2	3	4	5	6	7	8	9	10
57	60	KCS011470604	280	344	372	420	441	471	499	566	693	823	873
67	60	KCS011470607	289	353	381	433	457	485	514	583	712	848	898

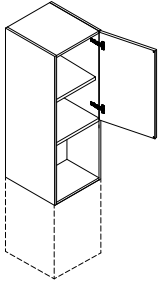

Colonna forno 2 ante + 2 cestoni

Oven tall unit 2 doors + 2 baskets
Colonne four 2 portes + 2 paniers
Columna horno 2 puertas + 2 cestas
Backofenschrank 2 Türen + 2 Schubkasten

Apertura solo con maniglia
Opening with handle only
Ouverture seulement avec la poignée
Apertura sólo con tirador
Öffnung nur mit Griff

P/D	L/W	CODICE	0	1	2	3	4	5	6	7	8	9	10
57	90	KCO262250904	710	805	857	958	1.073	1.199	1.342	1.440	1.776	2.150	2.244
67	90	KCO262250907	778	873	924	1.026	1.141	1.267	1.410	1.508	1.846	2.220	2.314

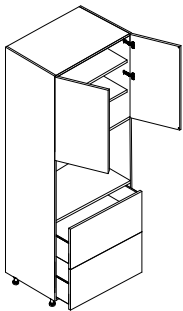

Basi con maniglia
Base units with handle

Basi con gola
Base units with groove

Colonne
Tall units

Pensili
Wall units

Elementi speciali
Special elements

Maniglie gole zoccoli
Handles grooves plinth

Illuminazione
Lighting

Accessori
Accessories

Componenti e meccanismi
Components e mechanism

COLONNE FORNO

H. 225

Oven tall units
Colonnes four
Columnas horno
Backofen-Hochschränke

Colonna forno H. 48 4 ante

Oven tall unit H 48 4 doors
Colonne four H 48 4 portes
Columna horno H 48 4 puertas
Backofenschrank H 48 4 Türen

Apertura solo con maniglia
Opening with handle only
Ouverture seulement avec la poignée
Apertura sólo con tirador
Öffnung nur mit Griff

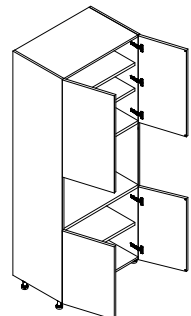

P/D	L/W	CODICE	0	1	2	3	4	5	6	7	8	9	10
57	90	KCP052250904	642	737	789	890	1.005	1.131	1.275	1.373	1.706	2.080	2.174
67	90	KCP052250907	710	805	857	958	1.073	1.199	1.342	1.440	1.776	2.150	2.244

Colonna forno H. 48 2 ante + 2 cestoni

Oven tall unit H 48 2 doors + 2 baskets
Colonne four H 48 2 portes + 2 paniers
Columna horno H 48 2 puertas + 2 cestas
Backofenschrank H 48 2 Türen + 2 Schubkasten

Apertura con gola orizzontale
Horizontal groove opening
Ouverture rainure horizontale
Apertura con uñero horizontal
Öffnung mit horizontaler Griffleiste

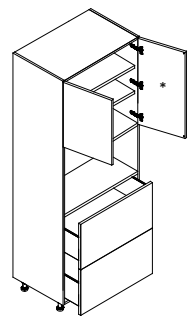

P/D	L/W	CODICE	0	1	2	3	4	5	6	7	8	9	10
57	90	KCJ262250904	710	805	857	958	1.073	1.199	1.342	1.440	1.776	2.150	2.244
67	90	KCJ262250907	778	873	924	1.026	1.141	1.267	1.410	1.508	1.846	2.220	2.314

* **Frontale su misura** | Customised front panel | Façade sur mesure | Frente medida especial | Fronten in Sondermasse

Colonna angolo forno 2 ante

Corner tall unit for oven 2 doors
Colonne four d'angle 2 portes
Columna ángulo 2 puertas para horno
Backofen Ecke-Hochschrank 2 Türen

Apertura con gola verticale o maniglia
Opening with vertical groove or handle
Ouverture avec rainure verticale ou poignée
Apertura con uñero vertical o tirador
Öffnung mit vertikaler Griffleiste

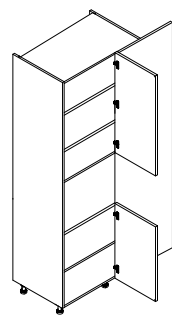

	P/D	L/W	CODICE	0	1	2	3	4	5	6	7	8	9	10
●	59,5	125	KCC022251254D/S	851	886	961	1.117	1.202	1.348	1.421	1.690	2.090	2.508	2.608
△	69,5	135	KCC022251357D/S	871	905	983	1.137	1.220	1.367	1.440	1.709	2.110	2.531	2.631

● **scocca da 75 cm** | 75 cm body | structure de 75 cm | estructura de 75 cm | 75 cm Korpus
△ **scocca da 120 cm** | 120 cm body | structure de 120 cm | estructura de 120 cm | 120 cm Korpus

COLONNE FRIGO

Fridge tall units
Colonnes frigo
Columnas nevera
Kühlschrank Hochschränke

H. 225

Colonna frigo H. 122,5 2 ante

Refrigerator tall unit H 122,5 2 doors
Colonne frigo H 122,5 2 portes
Columna nevera H 122,5 2 puertas
Kühlschrank Hochschrank H 122,5 2 Türen

Apertura con gola verticale o maniglia
Opening with vertical groove or handle
Ouverture avec rainure verticale ou poignée
Apertura con uñero vertical o tirador
Öffnung mit vertikaler Griffleiste

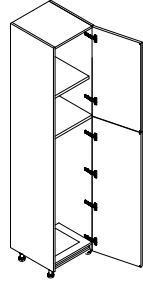

P/D	L/W	CODICE	0	1	2	3	4	5	6	7	8	9	10
57	60	KCF042250604	384	452	534	614	665	736	834	981	1.213	1.454	1.575
67	60	KCF042250607	404	472	557	635	684	756	853	999	1.238	1.485	1.603

Maggiorazione per apertura elettrica anta singola PUNTI 467

Surcharge for electric single door opening | Supplément pour ouverture électrique d'une porte seule | Recargo para apertura eléctrica puerta singular | Aufpreis für elektrische Türöffnung

Colonna frigo H. 178 1 anta

Refrigerator tall unit H 178 1 door
Colonne frigo H 178 1 porte
Columna nevera H 178 1 puerta
Kühlschrank Hochschrank H 178 1 Tür

Apertura con gola verticale o maniglia
Opening with vertical groove or handle
Ouverture avec rainure verticale ou poignée
Apertura con uñero vertical o tirador
Öffnung mit vertikaler Griffleiste

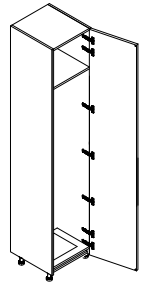

P/D	L/W	CODICE	0	1	2	3	4	5	6	7	8	9	10
57	60	KCF012250604	415	444	516	618	669	711	788	931	1.152	1.383	1.467
67	60	KCF012250607	430	460	532	636	689	732	809	960	1.187	1.424	1.495

Maggiorazione per apertura elettrica anta singola PUNTI 467

Surcharge for electric single door opening | Supplément pour ouverture électrique d'une porte seule | Recargo para apertura eléctrica puerta singular | Aufpreis für elektrische Türöffnung

Colonna frigo H. 122,5 2 ante

Refrigerator tall unit H 122,5 2 doors
Colonne frigo H 122,5 2 portes
Columna nevera H 122,5 2 puertas
Kühlschrank Hochschrank H 122,5 2 Türen

Apertura con gola verticale o maniglia
Opening with vertical groove or handle
Ouverture avec rainure verticale ou poignée
Apertura con uñero vertical o tirador
Öffnung mit vertikaler Griffleiste

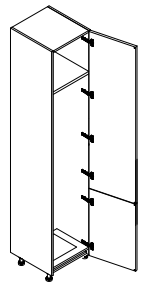

P/D	L/W	CODICE	0	1	2	3	4	5	6	7	8	9	10
57	60	KCF032250604	384	452	534	614	665	736	834	981	1.213	1.454	1.559
57	75	KCF032250754	463	543	642	738	799	884	1.002	1.177	1.456	1.746	1.841
67	60	KCF032250607	404	472	557	635	684	756	853	999	1.238	1.485	1.588
67	75	KCF032250757	485	567	666	762	821	906	1.023	1.201	1.485	1.783	1.871

Maggiorazione per apertura elettrica anta doppia PUNTI 934

Surcharge for electric double sash opening | Supplément pour l'ouverture électrique d'une porte double | Recargo para apertura eléctrica puerta doble | Aufpreis für elektrische Doppeltüröffnung

Basi con maniglia
Base units with handle

Basi con gola
Base units with groove

Colonne
Tall units

Pensili
Wall units

Elementi speciali
Special elements

Maniglie gole zoccoli
Handles grooves plinth

Illuminazione
Lighting

Accessori
Accessories

Componenti e meccanismi
Components e mechanism

COLONNE VETRINA

H. 225

Showcase tall units
Vitrine
Columnas vitrina
Glasstuer Hochschranke

Colonna vetrina 1 ante

Display tall unit 1 door
Vitrine 1 porte
Columna vitrina 1 puerta
Vitrinensäule 1 Tür

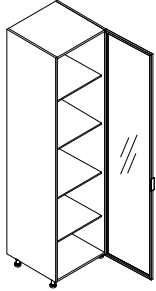

P/D	L/W	CODICE	0	1	2	3	4	5	6	7	8	9	10
34	45	KCV012250451	734	789	990	1.350	-	-	-	-	-	-	-
34	60	KCV012250601	843	906	1.138	1.551	-	-	-	-	-	-	-
57	45	KCV012250454	794	854	1.072	1.461	-	-	-	-	-	-	-
57	60	KCV012250604	930	999	1.255	1.711	-	-	-	-	-	-	-
67	45	KCV012250457	819	880	1.105	1.506	-	-	-	-	-	-	-
67	60	KCV012250607	956	1.027	1.290	1.758	-	-	-	-	-	-	-

Colonna vetrina 2 ante

Display tall unit 2 doors
Vitrine 2 portes
Columna vitrina 2 puertas
Hochschrank 2 Glasstüren

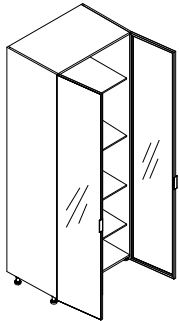

P/D	L/W	CODICE	0	1	2	3	4	5	6	7	8	9	10
34	90	KCV022250901	1.407	1.513	1.900	2.589	-	-	-	-	-	-	-
57	90	KCV022250904	1.443	1.551	1.948	2.655	-	-	-	-	-	-	-
67	90	KCV022250907	1.471	1.582	1.986	2.707	-	-	-	-	-	-	-

COLONNE USA

USA tall units
Colonne américaines
Columnas USA
US-Hochschränke

H. 225

Colonna USA (30") forno + microonde 2 ante + 1 cestone

USA tall unit (30") oven + microwave 2 doors + 1 drawer
Colonne USA (30") four + micro+ 2 portes + 1 panier
Columna USA (30") horno + microondas 2 puertas + 1 cajón
USA Hochschrank (30") Backofen + Mikrowelle 2 Türen + 1 Schublade

Apertura solo con maniglia

Opening with handle only
Ouverture seulement avec la poignée
Apertura sólo con tirador
Öffnung nur mit Griff

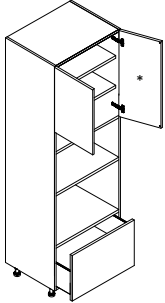

P/D	L/W	CODICE	0	1	2	3	4	5	6	7	8	9	10
57	76,2	KCM252250764	789	903	951	1.017	1.191	1.364	1.564	1.713	2.096	2.472	2.572
67	76,2	KCM252250767	857	971	1.019	1.084	1.259	1.432	1.632	1.781	2.166	2.542	2.642

* **Frontale su misura** | Customised front panel | Façade sur mesure | Frente medida especial | Fronten in Sondermasse

Colonna USA (30") forno 2 ante + 2 cestoni

USA tall unit (30") oven 2 doors + 2 baskets
Colonne USA C (30") four 2 portes + 2 paniers
Columna USA (30") horno 2 puertas + 2 cestas
USA Hochschrank (30") 2 Türen + 2 Schubkasten

Apertura solo con gola intermedia

Opening only with middle groove
Ouverture uniquement avec rainure intermédiaire
Apertura sólo con ranura intermedia
Schubladenöffnung nur mit Zwischennut

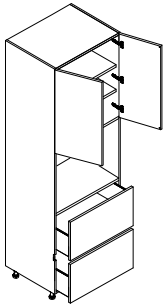

P/D	L/W	CODICE	0	1	2	3	4	5	6	7	8	9	10
57	76,2	KCH262250764	874	988	1.040	1.084	1.331	1.510	1.662	1.869	2.056	2.240	2.340
67	76,2	KCH262250767	942	1.056	1.108	1.152	1.399	1.578	1.730	1.937	2.126	2.310	2.410

Basi con maniglia
Base units with handle

Basi con gola
Base units with groove

Colonne
Tall units

Pensili
Wall units

Elementi speciali
Special elements

Maniglie gole zoccoli
Handles grooves plinth

Illuminazione
Lighting

Accessori
Accessories

Componenti e meccanismi
Components e mechanism

COLONNE

H. 240

Tall units
Colonnes
Columnas
Hochschranke

Riempitivo per colonna

Tall unit filler
Fileur pour colonne
Regleta para columna
Hochschrankfüller



L/W	CODICE	0	1	2	3	4	5	6	7	8	9	10
4-15	KCN902400151	167	187	220	284	297	307	340	407	505	605	655

Riempitivo per colonna 2 frontali

Tall unit filler 2 fronts
fileur pour colonnes 2 façades
Regleta para columna 2 frentes
Hochschrankfüller 2 Fronten



L/W	CODICE	0	1	2	3	4	5	6	7	8	9	10
4-15	KCN922400151	174	193	226	290	306	316	350	420	519	624	674

Riempitivo per colonna 2 frontali

Tall unit filler 2 fronts
fileur pour colonnes 2 façades
Regleta para columna 2 frentes
Hochschrankfüller 2 Fronten



L/W	CODICE	0	1	2	3	4	5	6	7	8	9	10
4-15	KCN912400151	174	193	226	290	306	316	350	420	519	624	674

COLONNE

Tall units
Colonnes
Columns
Hochschränke

H. 240

Colonna 1 anta

Tall unit 1 door
Colonne 1 porte
Columna 1 puerta
Hochschrank 1 Tür

Apertura con gola verticale o maniglia
Opening with vertical groove or handle
Ouverture avec rainure verticale ou poignée
Apertura con uñero vertical o tirador
Öffnung mit vertikaler Griffleiste

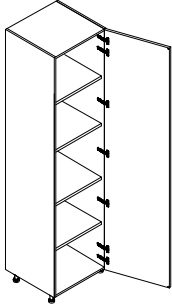

P/D	L/W	CODICE	0	1	2	3	4	5	6	7	8	9	10
34	30	KCN012400301	326	366	404	451	490	534	570	686	850	1.091	1.141
34	45	KCN012400451	344	413	487	544	589	674	725	860	1.065	1.367	1.417
34	60	KCN012400601	364	452	546	636	692	767	874	1.033	1.286	1.647	1.697
34	75	KCN012400751	443	552	664	772	837	929	1.057	1.249	1.553	1.985	2.035
57	30	KCN012400304	365	405	442	492	529	565	610	725	890	1.132	1.182
57	45	KCN012400454	383	452	527	585	629	715	764	900	1.107	1.408	1.458
57	60	KCN012400604	404	493	587	675	731	807	914	1.074	1.327	1.688	1.738
57	75	KCN012400754	483	592	704	812	878	969	1.097	1.288	1.593	2.025	2.075
67	30	KCN012400307	386	427	466	510	549	595	629	743	916	1.165	1.215
67	45	KCN012400457	405	474	546	606	652	733	785	830	1.133	1.442	1.492
67	60	KCN012400607	425	516	608	695	751	827	935	1.096	1.353	1.720	1.770
67	75	KCN012400757	509	620	730	834	901	993	1.122	1.315	1.624	2.064	2.114

Colonna 1 anta + 2 cestoni + 2 cassetti interni

Tall unit 1 door + 2 baskets + 2 internal drawers
Colonne 1 porte + 2 paniers + 2 tiroirs intérieurs
Columna 1 puerta + 2 cestas + 2 cajones interiores
Hochschrank 1 Tür + 2 Schubkasten + 2 Innenschubladen

Apertura con gola verticale o maniglia
Opening with vertical groove or handle
Ouverture avec rainure verticale ou poignée
Apertura con uñero vertical o tirador
Öffnung mit vertikaler Griffleiste

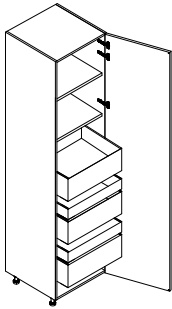

P/D	L/W	CODICE	0	1	2	3	4	5	6	7	8	9	10
57	45	KCK122400454	1.067	1.084	1.136	1.264	1.305	1.329	1.389	1.529	1.835	2.334	2.384
57	60	KCK122400604	1.114	1.141	1.216	1.357	1.410	1.458	1.542	1.713	2.059	2.619	2.669
57	75	KCK122400754	1.209	1.241	1.335	1.499	1.563	1.618	1.721	1.924	2.319	2.955	3.005
67	45	KCK122400457	1.180	1.198	1.246	1.374	1.417	1.441	1.502	1.641	1.974	2.448	2.498
67	60	KCK122400607	1.226	1.253	1.327	1.471	1.525	1.568	1.655	1.826	2.194	2.792	2.842
67	75	KCK122400757	1.321	1.353	1.444	1.611	1.675	1.730	1.832	2.036	2.454	3.128	3.178

Colonna 2 ante

Tall unit 2 doors
Colonne 2 portes
Columna 2 puertas
Hochschrank 2 Türen

Apertura solo con maniglia
Opening with handle only
Ouverture seulement avec la poignée
Apertura sólo con tirador
Öffnung nur mit Griff

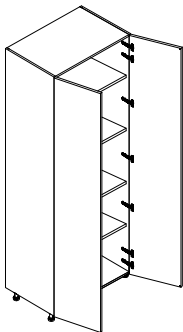

P/D	L/W	CODICE	0	1	2	3	4	5	6	7	8	9	10
34	90	KCN022400901	527	613	757	884	914	1.137	1.183	1.559	1.938	2.483	2.513
57	90	KCN022400904	595	682	825	952	982	1.205	1.251	1.627	2.008	2.553	2.603
67	90	KCN022400907	626	712	855	982	1.013	1.234	1.279	1.657	2.044	2.601	2.651

Basi con maniglia
Base units with handle

Basi con gola
Base units with groove

Colonne
Tall units

Pensili
Wall units

Elementi speciali
Special elements

Maniglie gole zoccoli
Handles grooves plinth

Illuminazione
Lighting

Accessori
Accessories

Componenti e meccanismi
Components e mechanism

COLONNE

Tall units
Colonnes
Columnas
Hochschränke

H. 240

Colonna 2 ante
Tall unit 2 doors
Colonne 2 portes
Columna 2 puertas
Hochschrank 2 Türen

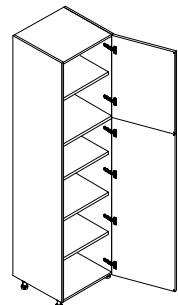

Apertura con gola verticale o maniglia
Opening with vertical groove or handle
Ouverture avec rainure verticale ou poignée
Apertura con uñero vertical o tirador
Öffnung mit vertikaler Griffleiste

P/D	L/W	CODICE	0	1	2	3	4	5	6	7	8	9	10
34	30	KCN042400301	326	366	404	451	490	534	570	686	850	1.091	1.141
34	45	KCN042400451	344	413	487	544	589	674	725	860	1.065	1.367	1.417
34	60	KCN042400601	364	452	546	636	692	767	874	1.033	1.286	1.647	1.697
34	75	KCN042400751	443	552	664	772	837	929	1.057	1.249	1.553	1.985	2.035
57	30	KCN042400304	365	405	442	492	529	565	610	725	890	1.132	1.182
57	45	KCN042400454	383	452	527	585	629	715	764	900	1.107	1.408	1.458
57	60	KCN042400604	404	493	587	675	731	807	914	1.074	1.327	1.688	1.738
57	75	KCN042400754	483	592	704	812	878	969	1.097	1.288	1.593	2.025	2.075
67	30	KCN042400307	386	427	466	510	549	595	629	743	916	1.165	1.215
67	45	KCN042400457	405	474	546	606	652	733	785	630	1.133	1.442	1.492
67	60	KCN042400607	425	516	608	695	751	827	935	1.096	1.353	1.720	1.770
67	75	KCN042400757	509	620	730	834	901	993	1.122	1.315	1.624	2.064	2.114

Colonna 4 ante
Tall unit 4-doors
Colonne 4 portes
Columna 4 puertas
4-türige Hochschrank

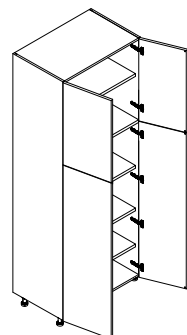

Apertura solo con maniglia
Opening with handle only
Ouverture seulement avec la poignée
Apertura sólo con tirador
Öffnung nur mit Griff

P/D	L/W	CODICE	0	1	2	3	4	5	6	7	8	9	10
34	90	KCN062400901	527	613	757	884	914	1.137	1.183	1.559	1.938	2.483	2.513
57	90	KCN062400904	595	682	825	952	982	1.205	1.251	1.627	2.008	2.553	2.603
67	90	KCN062400907	626	712	855	982	1.013	1.234	1.279	1.657	2.044	2.601	2.651

Colonna 2 ante
Tall unit 2 doors
Colonne 2 portes
Columna 2 puertas
Hochschrank 2 Türen

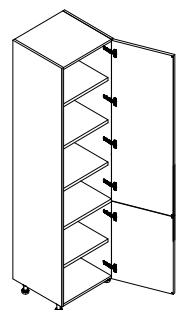

Apertura con gola verticale o maniglia
Opening with vertical groove or handle
Ouverture avec rainure verticale ou poignée
Apertura con uñero vertical o tirador
Öffnung mit vertikaler Griffleiste

P/D	L/W	CODICE	0	1	2	3	4	5	6	7	8	9	10
34	30	KCN032400301	326	366	404	451	490	534	570	686	850	1.091	1.141
34	45	KCN032400451	344	413	487	544	589	674	725	860	1.065	1.367	1.417
34	60	KCN032400601	364	452	546	636	692	767	874	1.033	1.286	1.647	1.697
34	75	KCN032400751	443	552	664	772	837	929	1.057	1.249	1.553	1.985	2.035
57	30	KCN032400304	365	405	442	492	529	565	610	725	890	1.132	1.182
57	45	KCN032400454	383	452	527	585	629	715	764	900	1.107	1.408	1.458
57	60	KCN032400604	404	493	587	675	731	807	914	1.074	1.327	1.688	1.738
57	75	KCN032400754	483	592	704	812	878	969	1.097	1.288	1.593	2.025	2.075
67	30	KCN032400307	386	427	466	510	549	595	629	743	916	1.165	1.215
67	45	KCN032400457	405	474	546	606	652	733	785	630	1.133	1.442	1.492
67	60	KCN032400607	425	516	608	695	751	827	935	1.096	1.353	1.720	1.770
67	75	KCN032400757	509	620	730	834	901	993	1.122	1.315	1.624	2.064	2.114

COLONNE

Tall units
Colonnes
Columnas
Hochschränke

H. 240

Colonna 4 ante

Tall unit 4-doors
Colonne 4 portes
Columna 4 puertas
4-türige Hochschrank

Apertura solo con maniglia

Opening with handle only
Ouverture seulement avec la poignée
Apertura sólo con tirador
Öffnung nur mit Griff

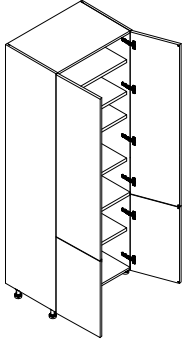

P/D	L/W	CODICE	0	1	2	3	4	5	6	7	8	9	10
34	90	KCN052400901	527	613	757	884	914	1.137	1.183	1.559	1.938	2.483	2.513
57	90	KCN052400904	595	682	825	952	982	1.205	1.251	1.627	2.008	2.553	2.603
67	90	KCN052400907	626	712	855	982	1.013	1.234	1.279	1.657	2.044	2.601	2.651

Colonna 2 ante + 3 cestoni interni

Tall unit 2 doors + 3 inner baskets
Colonne 2 portes + 3 paniers intérieurs
Columna 2 puertas + 3 cestas interiores
Hochschrank 2 Türen + 3 Innenschubkasten

Apertura con gola verticale o maniglia

Opening with vertical groove or handle
Ouverture avec rainure verticale ou poignée
Apertura con uñero vertical o tirador
Öffnung mit vertikaler Griffleiste

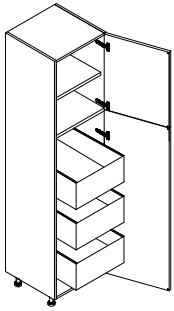

P/D	L/W	CODICE	0	1	2	3	4	5	6	7	8	9	10
57	45	KCK152400454	1.067	1.084	1.136	1.264	1.305	1.329	1.389	1.529	1.835	2.334	2.384
57	60	KCK152400604	1.114	1.141	1.216	1.357	1.410	1.458	1.542	1.713	2.059	2.619	2.669
57	75	KCK152400754	1.209	1.241	1.335	1.499	1.563	1.618	1.721	1.924	2.319	2.955	3.005
67	45	KCK152400457	1.180	1.198	1.246	1.374	1.417	1.441	1.502	1.641	1.974	2.448	2.498
67	60	KCK152400607	1.226	1.253	1.327	1.471	1.525	1.568	1.655	1.826	2.194	2.792	2.842
67	75	KCK152400757	1.321	1.353	1.444	1.611	1.675	1.730	1.832	2.036	2.454	3.128	3.178

Colonna 1 anta + 1 estraibile + 1 cestone interno

Tall unit 1 door + 1 pull-out + 1 inner basket
Colonne 1 porte + 1 extractible + 1 tiroirintérieur
Columna 1 puerta + 1 extraíble + 1 cajón interior
Hochschrank 1 Tür + 1 Auszug + 1 Innenschubkasten

Apertura con gola verticale o maniglia

Opening with vertical groove or handle
Ouverture avec rainure verticale ou poignée
Apertura con uñero vertical o tirador
Öffnung mit vertikaler Griffleiste

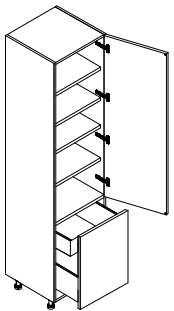

P/D	L/W	CODICE	0	1	2	3	4	5	6	7	8	9	10
57	45	KCN202400454	617	670	736	790	794	862	1.000	1.068	1.117	1.240	1.671
57	60	KCN202400604	695	749	838	891	933	1.001	1.200	1.268	1.314	1.507	1.979
57	75	KCN202400754	789	842	954	1.008	1.081	1.148	1.400	1.468	1.541	1.789	2.302
67	45	KCN202400457	668	722	788	841	846	914	1.051	1.119	1.170	1.293	1.725
67	60	KCN202400607	753	806	894	948	990	1.058	1.257	1.325	1.372	1.565	2.037
67	75	KCN202400757	851	904	1.017	1.071	1.144	1.212	1.462	1.530	1.606	1.853	2.366

Basi con maniglia
Base units with handle

Basi con gola
Base units with groove

Colonne
Tall units

Pensili
Wall units

Elementi speciali
Special elements

Maniglie gole zoccoli
Handles grooves plinth

Illuminazione
Lighting

Accessori
Accessories

Componenti e meccanismi
Components e mechanism

COLONNE

Tall units
Colonnes
Columnas
Hochschränke

H. 240

Colonna 1 anta + 4 cassetti

Tall unit 1 door + 4 drawers
Colonne 1 porte + 4 tiroirs
Columna 1 puerta + 4 cajones
Hochschrank 1 Tür + 4 Schubladen

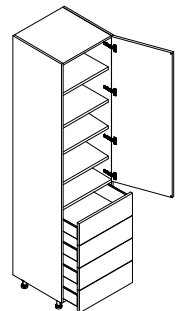

Apertura con gola verticale o maniglia
Opening with vertical groove or handle
Ouverture avec rainure verticale ou poignée
Apertura con uñero vertical o tirador
Öffnung mit vertikaler Griffleiste

P/D	L/W	CODICE	0	1	2	3	4	5	6	7	8	9	10
57	45	KCN242400454	673	726	825	879	920	987	1.130	1.198	1.405	1.518	1.936
57	60	KCN242400604	753	806	936	989	1.030	1.098	1.356	1.424	1.703	1.712	2.310
57	75	KCN242400754	835	889	1.051	1.103	1.151	1.219	1.589	1.657	1.891	1.941	2.687
67	45	KCN242400457	726	779	878	931	973	1.041	1.183	1.251	1.459	1.572	1.990
67	60	KCN242400607	812	865	996	1.050	1.089	1.157	1.415	1.483	1.765	1.773	2.371
67	75	KCN242400757	901	954	1.116	1.170	1.218	1.286	1.655	1.723	1.959	2.010	2.755

Colonna 1 anta + 2 cassetti + 1 cestone

Tall unit 1 door + 2 drawers + 1 basket
Colonne 1 porte + 2 tiroirs + 1 panier
Columna 1 puerta + 2 cajones + 1 cesta
Hochschrank 1 Tür + 2 Schubladen + 1 Schubkast

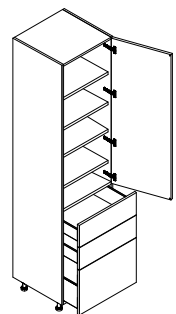

Apertura con gola verticale o maniglia
Opening with vertical groove or handle
Ouverture avec rainure verticale ou poignée
Apertura con uñero vertical o tirador
Öffnung mit vertikaler Griffleiste

P/D	L/W	CODICE	0	1	2	3	4	5	6	7	8	9	10
57	45	KCN232400454	626	679	766	820	837	905	1.051	1.119	1.327	1.350	1.818
57	60	KCN232400604	701	754	871	924	958	1.026	1.266	1.334	1.522	1.604	2.166
57	75	KCN232400754	781	834	980	1.033	1.089	1.157	1.488	1.556	1.698	1.838	2.519
67	45	KCN232400457	677	730	819	872	889	956	1.103	1.171	1.380	1.403	1.871
67	60	KCN232400607	759	812	928	982	1.017	1.084	1.324	1.392	1.581	1.663	2.225
67	75	KCN232400757	845	898	1.044	1.097	1.153	1.221	1.551	1.619	1.764	1.904	2.584

Colonna 1 anta + 2 cestoni

Tall unit 1 door + 2 baskets
Colonne 1 porte + 2 paniers
Columna 1 puerta + 2 cestas
Hochschrank 1 Tür + 2 Schubkasten

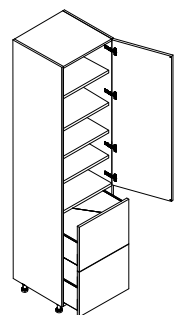

Apertura con gola verticale o maniglia
Opening with vertical groove or handle
Ouverture avec rainure verticale ou poignée
Apertura con uñero vertical o tirador
Öffnung mit vertikaler Griffleiste

P/D	L/W	CODICE	0	1	2	3	4	5	6	7	8	9	10
57	45	KCN222400454	578	631	708	761	755	823	973	1.041	1.182	1.249	1.700
57	60	KCN222400604	649	702	805	858	888	955	1.177	1.245	1.340	1.496	2.022
57	75	KCN222400754	727	780	909	962	1.027	1.095	1.386	1.454	1.505	1.735	2.350
67	45	KCN222400457	629	682	759	812	805	873	1.023	1.091	1.234	1.301	1.752
67	60	KCN222400607	705	759	861	915	944	1.012	1.233	1.301	1.398	1.554	2.080
67	75	KCN222400757	788	841	970	1.023	1.088	1.156	1.447	1.515	1.568	1.799	2.413

COLONNE

Tall units
Colonnes
Columns
Hochschränke

H. 240

Colonna 1 anta + 2 cestoni

Tall unit 1 door + 2 baskets
Colonne 1 porte + 2 paniers
Column 1 puerta + 2 cestas
Hochschrank 1 Tür + 2 Schubkasten

Apertura con gola orizzontale
Horizontal groove opening
Ouverture rainure horizontale
Apertura con uñero horizontal
Öffnung mit horizontaler Griffleiste

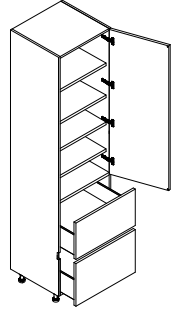

P/D	L/W	CODICE	0	1	2	3	4	5	6	7	8	9	10
57	45	KCG222400454	578	631	708	761	755	823	973	1.041	1.182	1.249	1.700
57	60	KCG222400604	649	702	805	858	888	955	1.177	1.245	1.340	1.496	2.022
57	75	KCG222400754	727	780	909	962	1.027	1.095	1.386	1.454	1.505	1.735	2.350
67	45	KCG222400457	629	682	759	812	805	873	1.023	1.091	1.234	1.301	1.752
67	60	KCG222400607	705	759	861	915	944	1.012	1.233	1.301	1.398	1.554	2.080
67	75	KCG222400757	788	841	970	1.023	1.088	1.156	1.447	1.515	1.568	1.799	2.413

Colonna 1 estraibile con meccanismo Linea Pro Sige

Tall unit 1 pull-out with mechanism Linea Pro Sige
Colonne 1 extractible avec mécanisme Linea Pro Sige
Column 1 extraíble con mecanismo Linea Pro Sige
Hochschrank 1 Auszug mit Mechanismus Linea Pro Sige

Apertura con gola verticale o maniglia
Opening with vertical groove or handle
Ouverture avec rainure verticale ou poignée
Apertura con uñero vertical o tirador
Öffnung mit vertikaler Griffleiste

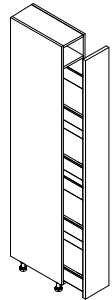

P/D	L/W	CODICE	0	1	2	3	4	5	6	7	8	9	10
57	30	KCN702400304	876	897	934	1.025	1.063	1.085	1.109	1.194	1.473	1.862	2.103
57	45	KCN702400454	955	976	1.013	1.136	1.160	1.194	1.213	1.389	1.711	2.164	2.607
67	30	KCN702400307	912	930	97	1.064	1.108	1.128	1.150	1.243	1.520	1.921	2.130
67	45	KCN702400457	996	1.016	1.054	1.178	1.207	1.238	1.259	1.439	1.766	2.235	2.637

Maggiorazione per meccanismo Linea Pure L. 30 Kessebohmer PUNTI 195

Mechanism Pure Line L. 30 Kessebohmer | Supplément pour le mécanisme Linea Pure L. 30 Kessebohmer | Recargo para mecanismo Linea Pure A.30 Kessebohmer | Aufpreis für Mechanismus Pure Line B. 30 Kessebohmer

Maggiorazione per meccanismo Linea Pure L. 45 Kessebohmer PUNTI 305

Mechanism Pure Line L. 45 Kessebohmer | Supplément pour le mécanisme Linea Pure L. 45 Kessebohmer | Recargo para mecanismo Linea Pure A.45 Kessebohmer | Aufpreis für Mechanik Pure Line B. 45 Kessebohmer

Colonna 2 estraibili con meccanismo Linea Pro Sige

Tall unit 2 pull-outs with mechanism Linea Pro Sige
Colonne 2 extractibles avec mécanisme Linea Pro Sige
Column 2 extraíbles con mecanismo Linea Pro Sige
Hochschrank 2 Auszüge mit Mechanismus Linea Pro Sige

Apertura con gola verticale o maniglia
Opening with vertical groove or handle
Ouverture avec rainure verticale ou poignée
Apertura con uñero vertical o tirador
Öffnung mit vertikaler Griffleiste

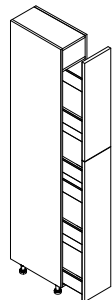

P/D	L/W	CODICE	0	1	2	3	4	5	6	7	8	9	10
57	30	KCN722400304	850	922	954	1.030	1.082	1.113	1.150	1.305	1.615	2.053	2.153
57	45	KCN722400454	897	991	1.052	1.155	1.213	1.251	1.304	1.504	1.862	2.367	2.467
67	30	KCN722400307	868	769	974	1.050	1.104	1.131	1.173	1.326	1.641	2.086	2.186
67	45	KCN722400457	919	1.012	1.074	1.176	1.234	1.272	1.323	1.526	1.884	2.396	2.496

Maggiorazione per meccanismo Linea Pure L. 30 Kessebohmer PUNTI 195

Mechanism Pure Line L. 30 Kessebohmer | Supplément pour le mécanisme Linea Pure L. 30 Kessebohmer | Recargo para mecanismo Linea Pure A.30 Kessebohmer | Aufpreis für Mechanismus Pure Line B. 30 Kessebohmer

Maggiorazione per meccanismo Linea Pure L. 45 Kessebohmer PUNTI 305

Mechanism Pure Line L. 45 Kessebohmer | Supplément pour le mécanisme Linea Pure L. 45 Kessebohmer | Recargo para mecanismo Linea Pure A.45 Kessebohmer | Aufpreis für Mechanik Pure Line B. 45 Kessebohmer

Basi con maniglia
Base units with handle

Basi con gola
Base units with groove

Colonne
Tall units

Pensili
Wall units

Elementi speciali
Special elements

Maniglie gole zoccoli
Handles grooves plinth

Illuminazione
Lighting

Accessori
Accessories

Componenti e meccanismi
Components e mechanism

COLONNE

Tall units
Colonnes
Columnas
Hochschränke

H. 240

Colonna 2 estraibili con meccanismo Linea Pro Sige

Tall unit 2 pull-outs with mechanism Linea Pro Sige
Colonne 2 extractibles avec mécanisme Linea Pro Sige
Columna 2 extraíbles con mecanismo Linea Pro Sige
Hochschrank 2 Auszüge mit Mechanismus Linea Pro Sige

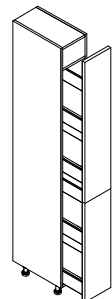

Apertura con gola verticale o maniglia
Opening with vertical groove or handle
Ouverture avec rainure verticale ou poignée
Apertura con uñero vertical o tirador
Öffnung mit vertikaler Griffleiste

P/D	L/W	CODICE	0	1	2	3	4	5	6	7	8	9	10
57	30	KCN712400304	850	922	954	1.030	1.082	1.113	1.150	1.305	1.615	2.053	2.153
57	45	KCN712400454	897	991	1.052	1.155	1.213	1.251	1.304	1.504	1.862	2.367	2.467
67	30	KCN712400307	868	769	974	1.050	1.104	1.131	1.173	1.326	1.641	2.086	2.186
67	45	KCN712400457	919	1.012	1.074	1.176	1.234	1.272	1.323	1.526	1.884	2.396	2.496

Maggiorazione per meccanismo Linea Pure L. 30 Kessebohmer PUNTI 195

Mechanism Pure Line L. 30 Kessebohmer | Supplément pour le mécanisme Linea Pure L. 30 Kessebohmer | Recargo para mecanismo Linea Pure A.30 Kessebohmer | Aufpreis für Mechanismus Pure Line B. 30 Kessebohmer

Maggiorazione per meccanismo Linea Pure L. 45 Kessebohmer PUNTI 305

Mechanism Pure Line L. 45 Kessebohmer | Supplément pour le mécanisme Linea Pure L. 45 Kessebohmer | Recargo para mecanismo Linea Pure A.45 Kessebohmer | Aufpreis für Mechanismus Pure Line B. 45 Kessebohmer

Colonna 1 anta con meccanismo Linea Pro Sige

Tall unit 1 door with mechanism Linea Pro Sige
Colonne 1 porte avec mécanisme Linea Pro Sige
Columna 1 puerta con mecanismo Linea Pro Sige
Hochschrank 1 Tür mit Mechanismus Linea Pro Sige

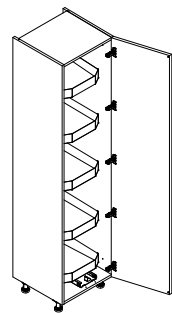

Apertura con gola verticale o maniglia
Opening with vertical groove or handle
Ouverture avec rainure verticale ou poignée
Apertura con uñero vertical o tirador
Öffnung mit vertikaler Griffleiste

P/D	L/W	CODICE	0	1	2	3	4	5	6	7	8	9	10
57	60	KCN752400604	1.475	1.498	1.575	1.718	1.773	1.820	1.903	2.059	2.287	2.910	3.010
67	60	KCN752400607	1.496	1.519	1.598	1.739	1.795	1.839	1.924	2.083	2.314	2.943	3.043

Maggiorazione per meccanismo Arena Style Kessebohmer PUNTI 857

Arena Style Kessebohmer mechanism | Supplément pour le mécanisme Arena Style Kessebohmer | Recargo para mecanismo Arena Style Kessebohmer | Aufpreis für Arena Style Kessebohmer Mechanismus

Colonna 1 anta con meccanismo Linea Pro Sige

Tall unit 1 door with mechanism Linea Pro Sige
Colonne 1 porte avec mécanisme Linea Pro Sige
Columna 1 puerta con mecanismo Linea Pro Sige
Hochschrank 1 Tür mit Mechanismus Linea Pro Sige

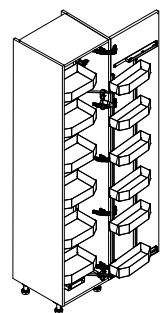

Apertura con gola verticale o maniglia
Opening with vertical groove or handle
Ouverture avec rainure verticale ou poignée
Apertura con uñero vertical o tirador
Öffnung mit vertikaler Griffleiste

P/D	L/W	CODICE	0	1	2	3	4	5	6	7	8	9	10
57	45	KCN742400454	1.245	1.372	1.405	1.502	1.550	1.595	1.639	1.798	2.184	2.777	2.877
57	60	KCN742400604	1.326	1.466	1.489	1.641	1.681	1.714	1.863	2.030	2.466	3.137	3.237
67	45	KCN742400457	1.267	1.393	1.424	1.524	1.568	1.615	1.660	1.819	2.206	2.808	2.908
67	60	KCN742400607	1.346	1.484	1.510	1.663	1.703	1.734	1.887	2.052	2.492	3.171	3.271

Maggiorazione per meccanismo Linea Pure L. 45 Kessebohmer PUNTI 438

Mechanism Pure Line L. 45 Kessebohmer | Supplément pour le mécanisme Linea Pure L. 45 Kessebohmer | Recargo para mecanismo Linea Pure A.45 Kessebohmer | Aufpreis für Mechanismus Pure Line B. 45 Kessebohmer

Maggiorazione per meccanismo Linea Pure L. 60 Kessebohmer PUNTI 657

Mechanism Pure Line L. 60 Kessebohmer | Supplément pour le mécanisme Linea Pure L. 60 Kessebohmer | Recargo para mecanismo Linea Pure A.60 Kessebohmer | Aufpreis für Mechanismus Pure Line L. 60 Kessebohmer

COLONNE

Tall units
Colonnes
Columnas
Hochschränke

H. 240

Colonna 1 anta portascopie

Tall unit 1-door broom
Colonne 1 porte pour balai
Columna 1 puerta para escobas
Hochschrank 1 Tür Besenstiel

Apertura con gola verticale o maniglia
Opening with vertical groove or handle
Ouverture avec rainure verticale ou poignée
Apertura con uñero vertical o tirador
Öffnung mit vertikaler Griffleiste

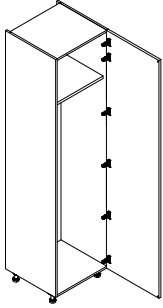

P/D	L/W	CODICE	0	1	2	3	4	5	6	7	8	9	10
57	45	KCN072400454	558	653	736	820	878	978	1.038	1.204	1.465	1.797	1.897
57	60	KCN072400604	663	776	885	1.007	1.073	1.167	1.296	1.494	1.824	2.241	2.341
67	45	KCN072400457	628	733	832	934	995	1.092	1.191	1.374	1.677	2.052	2.152
67	60	KCN072400607	687	805	913	1.031	1.099	1.192	1.322	1.519	1.855	2.276	2.376

Colonna 1 anta lavatrice - asciugatrice

Tall unit 1 door washer-dryer
Colonne 1 porte lave-linge- sèche-linge
Columna 1 puerta lavadora-secadora
Hochschrank 1 Tür Waschmaschine - Trockner

Apertura con gola verticale o maniglia
Opening with vertical groove or handle
Ouverture avec rainure verticale ou poignée
Apertura con uñero vertical o tirador
Öffnung mit vertikaler Griffleiste

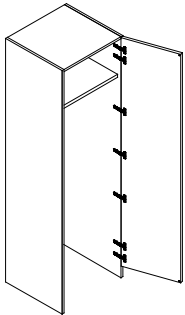

P/D	L/W	CODICE	0	1	2	3	4	5	6	7	8	9	10
67	69	KCN082400697	423	495	581	698	754	830	938	1.099	1.361	1.633	1.683

Colonna 2 ante lavatrice - asciugatrice

Tall unit 2 door washer-dryer
Colonne 2 portes lave-linge- sèche-linge
Columna 2 puertas lavadora-secadora
2-türige Waschmaschinen-Trockner-Hochschrank

Apertura solo con maniglia
Opening with handle only
Ouverture seulement avec la poignée
Apertura sólo con tirador
Öffnung nur mit Griff

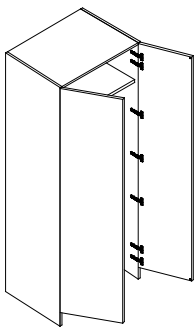

P/D	L/W	CODICE	0	1	2	3	4	5	6	7	8	9	10
67	90	KCN092400907	491	563	649	766	822	898	1.006	1.167	1.431	1.703	1.753

Basi con maniglia
Base units with handle

Basi con gola
Base units with groove

Colonne
Tall units

Pensili
Wall units

Elementi speciali
Special elements

Maniglie gole zoccoli
Handles grooves plinth

Illuminazione
Lighting

Accessori
Accessories

Componenti e meccanismi
Components e mechanism

COLONNE

Tall units
Colonnes
Columnas
Hochschränke

H. 240

Colonna angolo 1 anta
Corner tall unit 1 door
Colonne d'angle 1 porte
Columna ángulo 1 puerta
Eckehochschrank 1 Tür

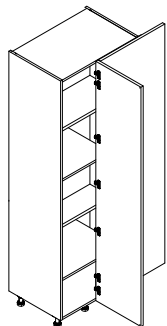

	P/D	L/W	CODICE	0	1	2	3	4	5	6	7	8	9	10
●	59,5	110	KCA012401104D/S	919	952	1.011	1.276	1.368	1.468	1.632	1.848	2.276	2.884	2.984
△	59,5	120	KCA012401204D/S	926	954	1.039	1.318	1.418	1.541	1.737	1.976	2.444	3.108	3.208
●	69,5	110	KCA012401107D/S	955	990	1.080	1.298	1.389	1.551	1.630	1.924	2.366	2.999	3.099
△	69,5	120	KCA012401207D/S	963	998	1.088	1.340	1.446	1.600	1.732	2.050	2.531	3.220	3.320

- **scocca da 75 cm** | 75 cm body | structure de 75 cm | estructura de 75 cm | 75 cm Korpus
- △ **scocca da 120 cm** | 120 cm body | structure de 120 cm | estructura de 120 cm | 120 cm Korpus

Colonna angolo 2 ante
Corner tall unit 2 doors
Colonne d'angle 2 portes
Columna ángulo 2 puertas
Eckehochschrank 2 Türen

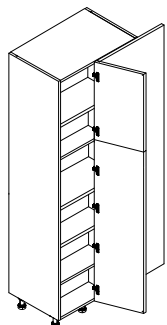

	P/D	L/W	CODICE	0	1	2	3	4	5	6	7	8	9	10
●	59,5	110	KCA042401104D/S	913	948	1.029	1.249	1.343	1.504	1.584	1.879	2.319	2.949	3.049
△	59,5	120	KCA042401204D/S	946	980	1.081	1.336	1.439	1.593	1.729	2.050	2.529	3.218	3.318
●	69,5	110	KCA042401107D/S	924	960	1.040	1.259	1.350	1.511	1.592	1.886	2.326	2.958	3.058
△	69,5	120	KCA042401207D/S	955	9.817	1.088	1.340	1.446	1.600	1.732	2.050	2.531	3.220	3.320

- **scocca da 75 cm** | 75 cm body | structure de 75 cm | estructura de 75 cm | 75 cm Korpus
- △ **scocca da 120 cm** | 120 cm body | structure de 120 cm | estructura de 120 cm | 120 cm Korpus

Colonna angolo 2 ante
Corner tall unit 2 doors
Colonne d'angle 2 portes
Columna ángulo 2 puertas
Eckehochschrank 2 Türen

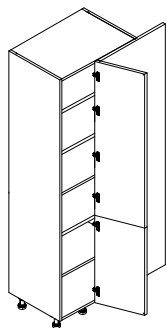

	P/D	L/W	CODICE	0	1	2	3	4	5	6	7	8	9	10
●	59,5	110	KCA032401104D/S	913	948	1.029	1.249	1.343	1.504	1.584	1.879	2.319	2.949	3.049
△	59,5	120	KCA032401204D/S	946	980	1.081	1.336	1.439	1.593	1.729	2.050	2.529	3.218	3.318
●	69,5	110	KCA032401107D/S	924	960	1.040	1.259	1.350	1.511	1.592	1.886	2.326	2.958	3.058
△	69,5	120	KCA032401207D/S	955	9.817	1.088	1.340	1.446	1.600	1.732	2.050	2.531	3.220	3.320

- **scocca da 75 cm** | 75 cm body | structure de 75 cm | estructura de 75 cm | 75 cm Korpus
- △ **scocca da 120 cm** | 120 cm body | structure de 120 cm | estructura de 120 cm | 120 cm Korpus

COLONNE

Tall units
Colonnes
Columns
Hochschränke

H. 240

Colonna angolo 1 ante con meccanismo Linea Pro Sige
Corner tall unit 1 door with mechanism Linea Pro Sige
Colonne d'angle 1 porte avec mécanisme Linea Pro Sige
Columna ángulo 1 puerta con mecanismo Linea Pro Sige
Eckehochschrank 1 Tür mit Mechanismus Linea Pro Sige

Apertura con gola verticale o maniglia
Opening with vertical groove or handle
Ouverture avec rainure verticale ou poignée
Apertura con uñero vertical o tirador
Öffnung mit vertikaler Griffleiste

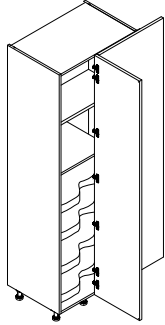

P/D	L/W	CODICE	0	1	2	3	4	5	6	7	8	9	10
○ 59,5	110	KCA762401104D/S	1.944	1.972	2.029	2.302	2.397	2.498	2.667	2.888	3.360	4.375	4.475
▲ 59,5	125	KCA762401254D/S	2.106	2.141	2.229	2.515	2.619	2.745	2.947	3.190	3.708	4.829	4.929
○ 69,5	120	KCA762401207D/S	1.981	2.012	2.067	2.346	2.443	2.545	2.717	2.944	3.425	4.461	4.561
▲ 69,5	135	KCA762401357D/S	2.149	2.183	2.273	2.566	2.671	2.799	3.004	3.253	3.782	4.925	5.025

- **scocca da 90 cm** | 90 cm body | structure de 90 cm | estructura de 90 cm | 90 cm Korpus
- ▲ **scocca da 105 cm** | 105 cm body | structure de 105 cm | estructura de 105 cm | 105 cm Korpus

Maggiorazione per meccanismo Linea Pure Kessebohmer PUNTI 645
Mechanism Pure Kessebohmer Line | Supplément pour le mécanisme Linea Pure Kessebohmer | Recargo para mecanismo Linea Pure Kessebohmer | Aufpreis für Mechanismus Pure Kessebohmer Line

Colonna angolo 2 ante con meccanismo Linea Pro Sige
Corner tall unit 2 doors with mechanism Linea Pro Sige
Colonne d'angle 2 portes avec mécanisme Linea Pro Sige
Columna ángulo 2 puertas con mecanismo Linea Pro Sige
2-türige Eckehochschrank mit Mechanismus Linea Pro Sige

Apertura con gola verticale o maniglia
Opening with vertical groove or handle
Ouverture avec rainure verticale ou poignée
Apertura con uñero vertical o tirador
Öffnung mit vertikaler Griffleiste

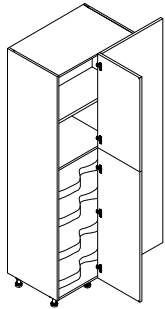

P/D	L/W	CODICE	0	1	2	3	4	5	6	7	8	9	10
○ 59,5	110	KCA782401104D/S	1.944	1.972	2.029	2.302	2.397	2.498	2.667	2.888	3.360	4.375	4.475
▲ 59,5	125	KCA782401254D/S	2.106	2.141	2.229	2.515	2.619	2.745	2.947	3.190	3.708	4.829	4.929
○ 69,5	120	KCA782401207D/S	1.981	2.012	2.067	2.346	2.443	2.545	2.717	2.944	3.425	4.461	4.561
▲ 69,5	135	KCA782401357D/S	2.149	2.183	2.273	2.566	2.671	2.799	3.004	3.253	3.782	4.925	5.025

- **scocca da 90 cm** | 90 cm body | structure de 90 cm | estructura de 90 cm | 90 cm Korpus
- ▲ **scocca da 105 cm** | 105 cm body | structure de 105 cm | estructura de 105 cm | 105 cm Korpus

Maggiorazione per meccanismo Linea Pure Kessebohmer PUNTI 645
Mechanism Pure Kessebohmer Line | Supplément pour le mécanisme Linea Pure Kessebohmer | Recargo para mecanismo Linea Pure Kessebohmer | Aufpreis für Mechanismus Pure Kessebohmer Line

Colonna angolo 2 ante con meccanismo Linea Pro Sige
Corner tall unit 2 doors with mechanism Linea Pro Sige
Colonne d'angle 2 portes avec mécanisme Linea Pro Sige
Columna ángulo 2 puertas con mecanismo Linea Pro Sige
2-türige Eckehochschrank mit Mechanismus Linea Pro Sige

Apertura con gola verticale o maniglia
Opening with vertical groove or handle
Ouverture avec rainure verticale ou poignée
Apertura con uñero vertical o tirador
Öffnung mit vertikaler Griffleiste

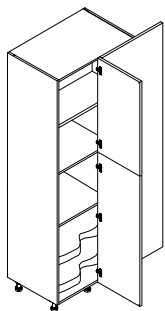

P/D	L/W	CODICE	0	1	2	3	4	5	6	7	8	9	10
○ 59,5	110	KCA772401104D/S	1.461	1.496	1.577	1.798	1.891	2.052	2.131	2.426	2.884	3.668	3.768
▲ 59,5	125	KCA772401254D/S	1.564	1.600	1.698	1.955	2.057	2.212	2.347	2.669	3.168	4.030	4.130
○ 69,5	120	KCA772401207D/S	1.502	1.536	1.620	1.846	1.940	2.108	2.187	2.491	2.964	3.768	3.868
▲ 69,5	135	KCA772401357D/S	1.648	1.684	1.788	2.055	2.164	2.327	2.470	2.805	3.335	4.355	4.455

- **scocca da 90 cm** | 90 cm body | structure de 90 cm | estructura de 90 cm | 90 cm Korpus
- ▲ **scocca da 105 cm** | 105 cm body | structure de 105 cm | estructura de 105 cm | 105 cm Korpus

Maggiorazione per meccanismo Linea Pure Kessebohmer PUNTI 269
Mechanism Pure Kessebohmer Line | Supplément pour le mécanisme Linea Pure Kessebohmer | Recargo para mecanismo Linea Pure Kessebohmer | Aufpreis für Mechanismus Pure Kessebohmer Line

Basi con maniglia
Base units with handle

Basi con gola
Base units with groove

Colonne
Tall units

Pensili
Wall units

Elementi speciali
Special elements

Maniglie gole zoccoli
Handles grooves plinth

Illuminazione
Lighting

Accessori
Accessories

Componenti e meccanismi
Components e mechanism

COLONNE

Tall units
Colonnes
Columnas
Hochschränke

H. 240

Colonna 1 anta copriboiler

Tall unit 1 door for water header / boiler
Colonne 1 porte pour cumulus
Columna 1 puerta para cubrir un boiler
Abdeckung der Wasser-warme

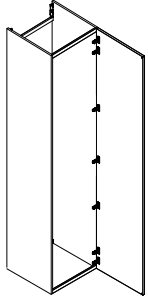

Apertura con gola verticale o maniglia
Opening with vertical groove or handle
Ouverture avec rainure verticale ou poignée
Apertura con uñero vertical o tirador
Öffnung mit vertikaler Griffleiste

P/D	L/W	CODICE	0	1	2	3	4	5	6	7	8	9	10
57	60	KCD012400604	537	566	604	667	677	723	770	864	1.003	1.177	1.227
67	60	KCD012400607	549	577	616	679	689	734	782	876	1.015	1.189	1.239

COLONNE FORNO

Oven tall units
Colonnes four
Columnas horno
Backofen-Hochschranke

H. 240

Colonna forno 2 ante (frontale superiore su misura)

Oven tall unit 2 doors (upper front made to measure)
Colonne four 2 portes (façade supérieure sur mesure)
Columna horno 2 puertas (frontal superior a medida)
Backofenschrank 2 Türen (obere Front nach Maß)

Apertura con gola verticale o maniglia
Opening with vertical groove or handle
Ouverture avec rainure verticale ou poignée
Apertura con uñero vertical o tirador
Öffnung mit vertikaler Griffleiste

P/D	L/W	CODICE	0	1	2	3	4	5	6	7	8	9	10
57	60	KCP022400604	459	537	566	662	707	764	826	960	1.168	1.404	1.493
67	60	KCP022400607	482	562	587	683	727	786	848	982	1.194	1.433	1.533

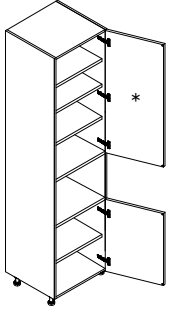

* Frontale su misura | Customised front panel | Façade sur mesure | Frente medida especial | Fronten in Sondermasse

Colonna forno 2 ante

Oven tall unit 2 doors
Colonne four 2 portes
Columna horno 2 puertas
Backofenschrank 2 Türen

Apertura con gola verticale o maniglia
Opening with vertical groove or handle
Ouverture avec rainure verticale ou poignée
Apertura con uñero vertical o tirador
Öffnung mit vertikaler Griffleiste

P/D	L/W	CODICE	0	1	2	3	4	5	6	7	8	9	10
57	60	KCO022400604	363	420	474	568	617	672	734	867	1.074	1.289	1.397
57	75	KCO022400754	421	486	550	661	714	780	852	1.005	1.245	1.494	1.641
67	60	KCO022400607	381	441	495	592	635	695	755	889	1.099	1.319	1.437
67	75	KCO022400757	443	512	574	686	736	805	874	1.029	1.275	1.528	1.686

□ forno L 75 cm | oven L 75 cm | four L 75 cm | horno L 75 cm | backofen B 75 cm

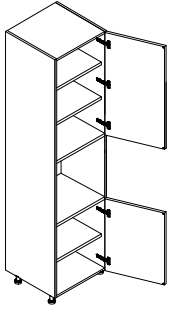

Colonna forno 1 anta + 1 estraibile + 1 cestone interno

Oven tall unit 1 door + 1 drawer + 1 inner basket
Colonne four 1 porte + 1 extractible + 1 tiroir intérieur
Columna horno 1 puerta + 1 cajón + 1 cajón interior
Backofenschrank 1 Tür + 1 Schublade + 1 Innenschubkast

Apertura con gola verticale o maniglia
Opening with vertical groove or handle
Ouverture avec rainure verticale ou poignée
Apertura con uñero vertical o tirador
Öffnung mit vertikaler Griffleiste

P/D	L/W	CODICE	0	1	2	3	4	5	6	7	8	9	10
57	60	KCO202400604	560	634	692	791	835	895	954	1.089	1.303	1.564	1.666
57	75	KCO202400754	690	782	852	972	1.027	1.100	1.174	1.339	1.601	1.921	1.933
67	60	KCO202400607	663	734	793	892	937	997	1.057	1.191	1.412	1.694	1.724
67	75	KCO202400757	818	908	979	1.099	1.153	1.228	1.302	1.466	1.736	2.084	2.184

□ forno L 75 cm | oven L 75 cm | four L 75 cm | horno L 75 cm | backofen B 75 cm

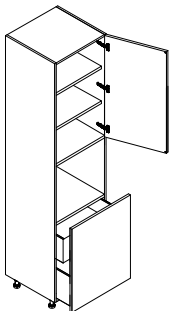

Basi con maniglia
Base units with handle

Basi con gola
Base units with groove

Colonne
Tall units

Pensili
Wall units

Elementi speciali
Special elements

Maniglie gole zoccoli
Handles grooves plinth

Illuminazione
Lighting

Accessori
Accessories

Componenti e meccanismi
Components e mechanism

COLONNE FORNO

H. 240

Oven tall units
Colonnes four
Columnas horno
Backofen-Hochschränke

Colonna forno 1 anta + 1 estraibile + 2 cassetti interni

Oven tall unit 1 door + 1 pull-out + 2 internal drawers
Colonne four 1 porte + 1 extractible + 2 tiroirs intérieurs
Columna horno 1 puerta + 1 extraíble + 2 cajones interiores
Backofenschrank 1 Tür + 1 Auszug + 2 Innenschubladen

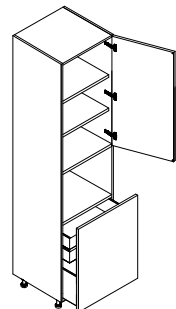

Apertura con gola verticale o maniglia
Opening with vertical groove or handle
Ouverture avec rainure verticale ou poignée
Apertura con uñero vertical o tirador
Öffnung mit vertikaler Griffleiste

P/D	L/W	CODICE	0	1	2	3	4	5	6	7	8	9	10
57	60	KC0212400604	628	702	760	858	903	963	1.022	1.157	1.373	1.634	1.736
□	57	75	KC0212400754	758	850	920	1.040	1.095	1.168	1.242	1.407	1.671	2.003
	67	60	KC0212400607	730	802	861	960	1.005	1.065	1.125	1.259	1.482	1.794
□	67	75	KC0212400757	886	976	1.047	1.167	1.221	1.296	1.370	1.534	1.806	2.254

□ **forno L 75 cm** | oven L 75 cm | four L 75 cm | horno L 75 cm | backofen B 75 cm

Colonna forno 1 anta + 4 cassetti

Oven tall unit 1 door + 4 drawers
Colonne four 1 porte + 4 tiroirs
Columna horno 1 puerta + 4 cajones
Backofenschrank 1 Tür + 4 Schubladen

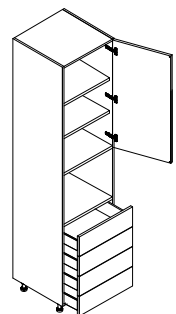

Apertura con gola verticale o maniglia
Opening with vertical groove or handle
Ouverture avec rainure verticale ou poignée
Apertura con uñero vertical o tirador
Öffnung mit vertikaler Griffleiste

P/D	L/W	CODICE	0	1	2	3	4	5	6	7	8	9	10
57	60	KC0242400604	671	780	837	968	1.027	1.062	1.161	1.303	1.608	1.929	1.997
□	57	75	KC0242400754	849	959	1.019	1.148	1.210	1.244	1.341	1.481	1.833	2.318
	67	60	KC0242400607	739	848	905	1.036	1.095	1.130	1.229	1.371	1.678	1.999
□	67	75	KC0242400757	917	1.027	1.086	1.215	1.277	1.311	1.408	1.549	1.903	2.388

□ **forno L 75 cm** | oven L 75 cm | four L 75 cm | horno L 75 cm | backofen B 75 cm

Colonna forno 1 anta + 2 cassetti + 1 cestone

Oven tall unit 1 door + 2 drawers + 1 drawer
Colonne four 1 porte + 2 tiroirs + 1 tiroir
Columna horno 1 puerta + 2 cajones + 1 cajón
Backofenschrank 1 Tür + 2 Schubladen + 1 Schublade

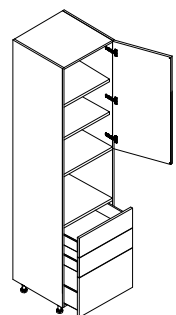

Apertura con gola verticale o maniglia
Opening with vertical groove or handle
Ouverture avec rainure verticale ou poignée
Apertura con uñero vertical o tirador
Öffnung mit vertikaler Griffleiste

P/D	L/W	CODICE	0	1	2	3	4	5	6	7	8	9	10
57	60	KC0232400604	637	745	798	917	976	1.020	1.081	1.245	1.537	1.844	1.944
□	57	75	KC0232400754	794	904	954	1.073	1.131	1.176	1.238	1.404	1.730	2.076
	67	60	KC0232400607	777	863	925	1.061	1.130	1.181	1.252	1.443	1.779	2.136
□	67	75	KC0232400757	968	1.049	1.107	1.243	1.310	1.362	1.434	1.627	2.005	2.504

□ **forno L 75 cm** | oven L 75 cm | four L 75 cm | horno L 75 cm | backofen B 75 cm

COLONNE FORNO

Oven tall units
Colonnes four
Columnas horno
Backofen-Hochschranke

H. 240

Colonna forno 1 anta + 2 cestoni

Oven tall unit 1 door + 2 baskets
Colonne four 1 porte + 2 paniers
Columna horno 1 puerta + 2 cestas
Backofenschrank 1 Tür + 2 Schubkasten

Apertura con gola verticale o maniglia
Opening with vertical groove or handle
Ouverture avec rainure verticale ou poignée
Apertura con uñero vertical o tirador
Öffnung mit vertikaler Griffleiste

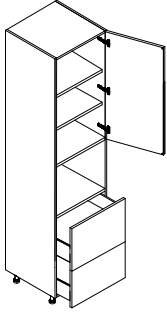

P/D	L/W	CODICE	0	1	2	3	4	5	6	7	8	9	10
57	60	KCO222400604	585	684	733	843	893	949	993	1.162	1.427	1.712	1.762
57	75	KCO222400754	699	799	850	956	1.010	1.064	1.108	1.278	1.573	1.885	1.981
67	60	KCO222400607	712	792	851	977	1.036	1.100	1.150	1.348	1.654	1.982	2.032
67	75	KCO222400757	852	926	985	1.109	1.169	1.234	1.284	1.481	1.822	2.183	2.233

Colonna forno 1 anta + 2 cestoni

Oven tall unit 1 door + 2 baskets
Colonne four 1 porte + 2 paniers
Columna horno 1 puerta + 2 cestas
Backofenschrank 1 Tür + 2 Schubkasten

Apertura con gola orizzontale
Horizontal groove opening
Ouverture rainure horizontale
Apertura con uñero horizontal
Öffnung mit horizontaler Griffleiste

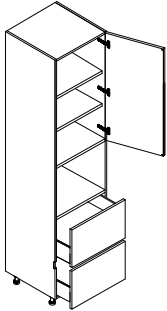

P/D	L/W	CODICE	0	1	2	3	4	5	6	7	8	9	10
57	60	KCH222400604	585	684	733	843	893	949	993	1.162	1.427	1.712	1.762
57	75	KCH222400754	699	799	850	956	1.010	1.064	1.108	1.278	1.573	1.885	1.981
67	60	KCH222400607	712	792	851	977	1.036	1.100	1.150	1.348	1.654	1.982	2.032
67	75	KCH222400757	852	926	985	1.109	1.169	1.234	1.284	1.481	1.822	2.183	2.233

Colonna forno + microonde 1 anta + 1 cestone

Tall unit oven + microwave 1 door + 1 drawer
Colonne four + micro 1 porte + 1 panier
Columna horno + microondas 1 puerta + 1 cajón
Schrankofen + Mikrowelle 1 Tür + 1 Schublade

Apertura con gola verticale o maniglia
Opening with vertical groove or handle
Ouverture avec rainure verticale ou poignée
Apertura con uñero vertical o tirador
Öffnung mit vertikaler Griffleiste

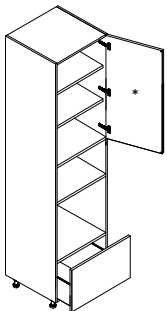

P/D	L/W	CODICE	0	1	2	3	4	5	6	7	8	9	10
57	60	KCM272400604	507	602	657	760	815	868	914	1.083	1.330	1.597	1.647
67	60	KCM272400607	574	672	724	830	883	938	981	1.150	1.415	1.697	1.747

* Frontale su misura | Customised front panel | Façade sur mesure | Frente medida especial | Fronten in Sondermasse

Basi con maniglia
Base units with handle

Basi con gola
Base units with groove

Colonne
Tall units

Pensili
Wall units

Elementi speciali
Special elements

Maniglie gole zoccoli
Handles grooves plinth

Illuminazione
Lighting

Accessori
Accessories

Componenti e meccanismi
Components e mechanism

COLONNE FORNO

Oven tall units
Colonnes four
Columnas horno
Backofen-Hochschränke

H. 240

Colonna forno + cantinetta 1 anta + 1 frontale fisso

Tall unit oven + wine cellar 1 door + 1 fixed front
Colonne four + cave à vin 1 porte + 1 façade fixe
Columna para horno+ espacio para vinos + 1 frente fijo
Schrankofen + Weinkeller 1 Tür + 1 feste Front

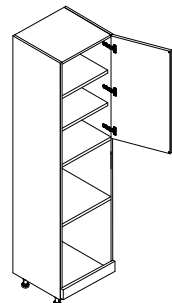

Apertura con gola verticale o maniglia
Opening with vertical groove or handle
Ouverture avec rainure verticale ou poignée
Apertura con uñero vertical o tirador
Öffnung mit vertikaler Griffleiste

P/D	L/W	CODICE	0	1	2	3	4	5	6	7	8	9	10
57	60	KCQ312400604	355	408	456	542	584	634	689	807	1.000	1.198	1.248
57	60	KCQ312400607	373	431	476	566	602	656	708	832	1.025	1.229	1.279

Colonna forno + microonde 2 ante

Oven tall unit + microwave 2 doors
Colonne four+ micro 2 portes
Horno columna + microondas 2 puertas
Schrankofen + Mikrowelle 2 Türen

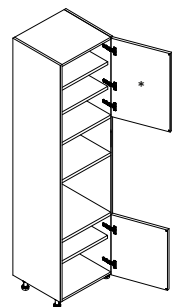

Apertura con gola verticale o maniglia
Opening with vertical groove or handle
Ouverture avec rainure verticale ou poignée
Apertura con uñero vertical o tirador
Öffnung mit vertikaler Griffleiste

P/D	L/W	CODICE	0	1	2	3	4	5	6	7	8	9	10
57	60	KCM022400604	377	458	532	639	660	695	748	853	1.041	1.244	1.294
67	60	KCM022400607	400	480	553	662	680	718	749	859	1.050	1.257	1.307

* **Frontale su misura** | Customised front panel | Façade sur mesure | Frente medida especial | Fronten in Sondermasse

Colonna forno + microonde 1 anta + 1 cassetto + 1 cestone

Tall unit oven + microwave 1 door + 1 drawer + 1 drawer
Colonne four + micro 1 porte + 1 tiroir + 1 panier
Columna horno + microondas 1 puerta + 1 cajón + 1 cajón
Schrankofen + Mikrowelle 1 Tür + 1 Schublade + 1 Schublade

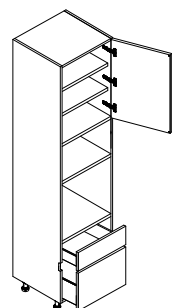

Apertura con gola verticale o maniglia
Opening with vertical groove or handle
Ouverture avec rainure verticale ou poignée
Apertura con uñero vertical o tirador
Öffnung mit vertikaler Griffleiste

P/D	L/W	CODICE	0	1	2	3	4	5	6	7	8	9	10
57	60	KCM282400604	595	692	743	851	902	960	1.000	1.173	1.441	1.729	1.779
67	60	KCM282400607	707	805	857	963	1.014	1.073	1.115	1.285	1.573	1.893	1.943

* **Frontale su misura** | Customised front panel | Façade sur mesure | Frente medida especial | Fronten in Sondermasse

COLONNE FORNO

Oven tall units
Colonnes four
Columnas horno
Backofen-Hochschranke

H. 240

Colonna forno + microonde 1 anta + 1 cassetto + 1 cestone

Tall unit oven + microwave 1 door + 1 drawer + 1 drawer
Colonne four + micro 1 porte + 1 tiroir + 1 panier
Columna horno + microondas 1 puerta + 1 cajón + 1 cajón
Schrankofen + Mikrowelle 1 Tür + 1 Schublade + 1 Schublade

Apertura con gola orizzontale
Horizontal groove opening
Ouverture rainure horizontale
Apertura con uñero horizontal
Öffnung mit horizontaler Griffleiste

P/D	L/W	CODICE	0	1	2	3	4	5	6	7	8	9	10
57	60	KCI282400604	595	692	743	851	902	960	1.000	1.173	1.441	1.729	1.779
67	60	KCI282400607	707	805	857	963	1.014	1.073	1.115	1.285	1.573	1.893	1.943

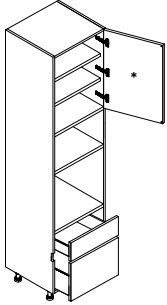

* Frontale su misura | Customised front panel | Façade sur mesure | Frente medida especial | Fronten in Sondermasse

Colonna forno sospesa 1 anta (sopra lavastoviglie)

Suspended oven tall unit 1 door (above dishwasher)
Colonne four suspendue 1 porte (au-dessus du lave-vaisselle)
Columna horno suspendida 1 puerta (sobre lavavajillas)
Haenge Backofenschrank 1 Tür (über Geschirrspüler)

Apertura con gola verticale o maniglia
Opening with vertical groove or handle
Ouverture avec rainure verticale ou poignée
Apertura con uñero vertical o tirador
Öffnung mit vertikaler Griffleiste

P/D	L/W	CODICE	0	1	2	3	4	5	6	7	8	9	10
57	60	KCS011620604	304	366	395	446	469	500	529	599	736	874	934
67	60	KCS011620607	312	374	405	459	484	515	545	619	755	898	948

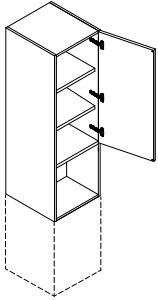

Colonna forno 2 ante + 2 cestoni

Oven tall unit 2 doors + 2 baskets
Colonne four 2 portes + 2 paniers
Columna horno 2 puertas + 2 cestas
Backofenschrank 2 Türen + 2 Schubkasten

Apertura solo con maniglia
Opening with handle only
Ouverture seulement avec la poignée
Apertura sólo con tirador
Öffnung nur mit Griff

P/D	L/W	CODICE	0	1	2	3	4	5	6	7	8	9	10
57	90	KCO262400904	774	879	935	1.048	1.174	1.312	1.470	1.578	1.927	2.358	2.458
67	90	KCO262400907	842	947	1.003	1.116	1.242	1.380	1.537	1.646	1.997	2.428	2.528

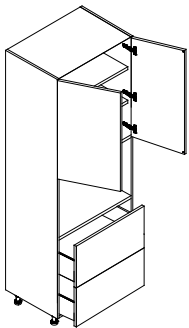

Basi con maniglia
Base units with handle

Basi con gola
Base units with groove

Colonne
Tall units

Pensili
Wall units

Elementi speciali
Special elements

Maniglie gole zoccoli
Handles grooves plinth

Illuminazione
Lighting

Accessori
Accessories

Componenti e meccanismi
Components e mechanism

COLONNE FORNO

H. 240

Oven tall units
Colonnes four
Columnas horno
Backofen-Hochschränke

Colonna forno H. 48 4 ante

Oven tall unit H 48 4 doors
Colonne four H 48 4 portes
Columna horno H 48 4 puertas
Backofenschrank H 48 4 Türen

Apertura solo con maniglia
Opening with handle only
Ouverture seulement avec la poignée
Apertura sólo con tirador
Öffnung nur mit Griff

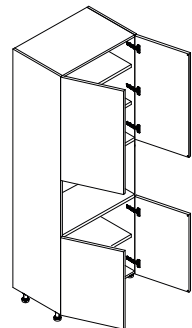

P/D	L/W	CODICE	0	1	2	3	4	5	6	7	8	9	10
57	90	KCP052400904	706	811	867	980	1.106	1.245	1.402	1.510	1.857	2.288	2.388
67	90	KCP052400907	774	879	935	1.048	1.174	1.312	1.470	1.578	1.927	2.358	2.458

Colonna forno H. 48 2 ante + 2 cestoni

Oven tall unit H 48 2 doors + 2 baskets
Colonne four H 48 2 portes + 2 paniers
Columna horno H 48 2 puertas + 2 cestas
Backofenschrank H 48 2 Türen + 2 Schubkasten

Apertura con gola orizzontale
Horizontal groove opening
Ouverture rainure horizontale
Apertura con uñero horizontal
Öffnung mit horizontaler Griffleiste

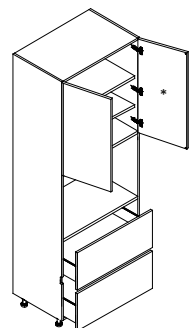

P/D	L/W	CODICE	0	1	2	3	4	5	6	7	8	9	10
57	90	KCJ262400904	774	879	935	1.048	1.174	1.312	1.470	1.578	1.927	2.358	2.458
67	90	KCJ262400907	842	947	1.003	1.116	1.242	1.380	1.537	1.646	1.997	2.428	2.528

* **Frontale su misura** | Customised front panel | Façade sur mesure | Frente medida especial | Fronten in Sondermasse

COLONNE FRIGO

Fridge tall units
Colonnes frigo
Columnas nevera
Kühlschrank Hochschränke

H. 240

Colonna frigo H. 122,5 2 ante

Refrigerator tall unit H 122,5 2 doors
Colonne frigo H 122,5 2 portes
Columna nevera H 122,5 2 puertas
Kühlschrank Hochschrank H 122,5 2 Türen

Apertura con gola verticale o maniglia
Opening with vertical groove or handle
Ouverture avec rainure verticale ou poignée
Apertura con uñero vertical o tirador
Öffnung mit vertikaler Griffleiste

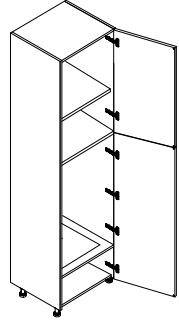

P/D	L/W	CODICE	0	1	2	3	4	5	6	7	8	9	10
57	60	KCF042400604	424	499	588	675	732	808	918	1.080	1.334	1.600	1.661
67	60	KCF042400607	443	520	611	698	754	830	938	1.099	1.361	1.633	1.691

Maggiorazione per apertura elettrica anta singola PUNTI 467

Surcharge for electric single door opening | Supplément pour ouverture électrique d'une porte seule | Recargo para apertura eléctrica puerta singular | Aufpreis für elektrische Türöffnung

Colonna frigo H. 178 1 anta

Refrigerator tall unit H 178 1 door
Colonne frigo H 178 1 porte
Columna nevera H 178 1 puerta
Kühlschrank Hochschrank H 178 1 Tür

Apertura con gola verticale o maniglia
Opening with vertical groove or handle
Ouverture avec rainure verticale ou poignée
Apertura con uñero vertical o tirador
Öffnung mit vertikaler Griffleiste

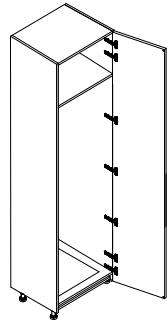

P/D	L/W	CODICE	0	1	2	3	4	5	6	7	8	9	10
57	60	KCF012400604	499	532	609	717	773	821	904	1.063	1.308	1.559	1.659
67	60	KCF012400607	512	544	626	738	796	845	930	1.093	1.345	1.607	1.707

Maggiorazione per apertura elettrica anta singola PUNTI 467

Surcharge for electric single door opening | Supplément pour ouverture électrique d'une porte seule | Recargo para apertura eléctrica puerta singular | Aufpreis für elektrische Türöffnung

Colonna frigo H. 178 2 ante

Refrigerator tall unit H 178 2 doors
Colonne frigo H 178 2 portes
Columna nevera H 178 2 puertas
Kühlschrank Hochschrank H 178 2 Türen

Apertura con gola verticale o maniglia
Opening with vertical groove or handle
Ouverture avec rainure verticale ou poignée
Apertura con uñero vertical o tirador
Öffnung mit vertikaler Griffleiste

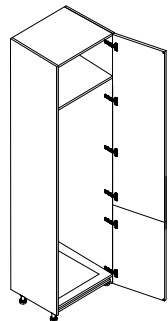

P/D	L/W	CODICE	0	1	2	3	4	5	6	7	8	9	10
57	60	KCF032400604	424	499	588	675	732	808	918	1.080	1.334	1.600	1.645
57	75	KCF032400754	508	598	705	812	880	970	1.100	1.296	1.601	1.920	1.941
67	60	KCF032400607	443	520	611	698	754	830	938	1.099	1.361	1.633	1.675
67	75	KCF032400757	534	624	733	839	903	996	1.126	1.319	1.633	1.960	1.973

Maggiorazione per apertura elettrica anta doppia PUNTI 934

Surcharge for electric double sash opening | Supplément pour l'ouverture électrique d'une porte double | Recargo para apertura eléctrica puerta doble | Aufpreis für elektrische Doppeltüröffnung

Basi con maniglia
Base units with handle

Basi con gola
Base units with groove

Colonne
Tall units

Pensili
Wall units

Elementi speciali
Special elements

Maniglie gole zoccoli
Handles grooves plinth

Illuminazione
Lighting

Accessori
Accessories

Componenti e meccanismi
Components e mechanism

COLONNE USA

USA tall units
Colonne américaines
Columnas USA
US-Hochschränke

H. 240

Colonna USA (30") forno + microonde 2 ante + 1 cestone

USA tall unit (30") oven + microwave 2 doors + 1 drawer
Colonne USA (30") four + micro+ 2 portes + 1 panier
Columna USA (30") horno + microondas 2 puertas + 1 cajón
USA Hochschrank (30") Backofen + Mikrowelle 2 Türen + 1 Schublade

Apertura solo con maniglia
Opening with handle only
Ouverture seulement avec la poignée
Apertura sólo con tirador
Öffnung nur mit Griff

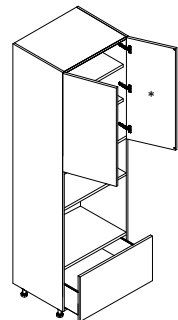

P/D	L/W	CODICE	0	1	2	3	4	5	6	7	8	9	10
57	76,2	KCM252400764	857	971	1.019	1.084	1.259	1.432	1.632	1.781	2.166	2.542	2.642
67	76,2	KCM252400767	924	1.039	1.086	1.152	1.327	1.500	1.699	1.849	2.236	2.612	2.712

* **Frontale su misura** | Customised front panel | Façade sur mesure | Frente medida especial | Fronten in Sondermasse

Colonna USA (30") forno 2 ante + 2 cestoni

USA tall unit (30") oven 2 doors + 2 baskets
Colonne USA C (30") four 2 portes + 2 paniers
Columna USA (30") horno 2 puertas + 2 cestas
USA Hochschrank (30") 2 Türen + 2 Schubkasten

Apertura con gola orizzontale
Horizontal groove opening
Ouverture rainure horizontale
Apertura con uñero horizontal
Öffnung mit horizontaler Griffleiste

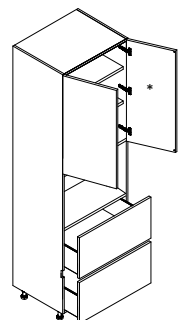

P/D	L/W	CODICE	0	1	2	3	4	5	6	7	8	9	10
57	76,2	KCH262400764	942	1.056	1.108	1.152	1.399	1.578	1.730	1.937	2.126	2.310	2.410
67	76,2	KCH262400767	1.010	1.124	1.176	1.220	1.467	1.646	1.797	2.005	2.196	2.380	2.480

PENSILI SOPRACOLONNA

H. 39

Overhead cabinets
Armoires suspendues
Overhead cabinets
Hängeschränke

Sopracolonna 2 ante

Sopracolumn 2 doors
Sopracolonne 2 portes
Sobre columna 2 puertas
Soprakolumne 2 Türen

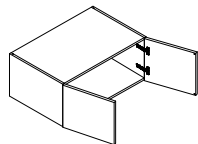

Apertura solo con maniglia

Opening with handle only
Ouverture seulement avec la poignée
Apertura sólo con tirador
Öffnung nur mit Griff

P/D	L/W	CODICE	0	1	2	3	4	5	6	7	8	9	10
57	90	KSV020390904	153	181	193	221	238	247	265	306	375	449	499
57	120	KSV020391204	158	190	209	238	262	272	299	340	418	500	550

Sopracolonna 1 vasistas

Sopracolumn 1 vasistas
Sopracolumn 1 vasistas
Sobre columna 1 abatible
Soprakolumne 1 vasistas

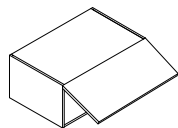

Apertura solo con maniglia

Opening with handle only
Ouverture seulement avec la poignée
Apertura sólo con tirador
Öffnung nur mit Griff

P/D	L/W	CODICE	0	1	2	3	4	5	6	7	8	9	10
57	90	KSV400390904	299	307	341	378	416	435	469	537	662	793	843
57	120	KSV400391204	309	318	353	390	430	448	483	554	682	818	868

Maggiorazione per apertura elettrica anta vasistas PUNTI 467

Surcharge for electric vasistas door opening | Supplément pour l'ouverture électrique de la porte vasistas | Recargo para apertura eléctrica puerta abatible | Aufpreis für die elektrische Öffnung der Klapptür

Basi con maniglia
Base units with handle

Basi con gola
Base units with groove

Colonne
Tall units

Pensili
Wall units

Elementi speciali
Special elements

Maniglie gole zoccoli
Handles grooves plinth

Illuminazione
Lighting

Accessori
Accessories

Componenti e meccanismi
Components e mechanism

PENSILI SOPRACOLONNA

H. 45,5

Overhead cabinets
Armoires suspendues
Overhead cabinets
Hängeschränke

Sopracolonna 2 ante
Sopracolumn 2 doors
Sopracolonne 2 portes
Sobre columna 2 puertas
Soprakolumne 2 Türen

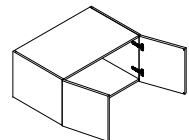

Apertura solo con maniglia
Opening with handle only
Ouverture seulement avec la poignée
Apertura sólo con tirador
Öffnung nur mit Griff

P/D	L/W	CODICE	0	1	2	3	4	5	6	7	8	9	10
57	90	KSV020450904	200	243	269	312	348	355	396	464	570	682	732
57	120	KSV020451204	210	254	278	335	362	366	407	473	583	699	749

Sopracolonna 1 vasistas
Sopracolumn 1 vasistas
Sopracolumn 1 vasistas
Sobre columna 1 abatible
Soprakolumne 1 vasistas

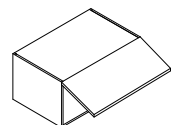

Apertura solo con maniglia
Opening with handle only
Ouverture seulement avec la poignée
Apertura sólo con tirador
Öffnung nur mit Griff

P/D	L/W	CODICE	0	1	2	3	4	5	6	7	8	9	10
57	90	KSV400450904	307	339	362	400	440	443	468	588	721	865	915
57	120	KSV400451204	321	352	375	407	442	457	481	600	736	883	933

Maggiorazione per apertura elettrica anta vasistas PUNTI 467

Surcharge for electric vasistas door opening | Supplément pour l'ouverture électrique de la porte vasistas | Recargo para apertura eléctrica puerta abatible | Aufpreis für die elektrische Öffnung der Klapptür

PENSILI SOPRACOLONNA

H. 57

Overhead cabinets
Armoires suspendues
Overhead cabinets
Hängeschränke

Sopracolonna 2 ante
Sopracolumn 2 doors
Sopracolonne 2 portes
Sobre columna 2 puertas
Soprakolumne 2 Türen

Apertura solo con maniglia
Opening with handle only
Ouverture seulement avec la poignée
Apertura sólo con tirador
Öffnung nur mit Griff

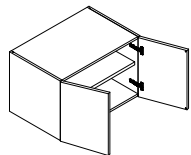

P/D	L/W	CODICE	0	1	2	3	4	5	6	7	8	9	10
57	90	KSV020570904	204	252	290	365	412	425	459	559	690	827	877
57	120	KSV020571204	213	263	303	375	424	437	469	567	703	843	993

Sopracolonna 1 vasistas
Sopracolumn 1 vasistas
Sopracolumn 1 vasistas
Sobre columna 1 abatible
Soprakolumne 1 vasistas

Apertura solo con maniglia
Opening with handle only
Ouverture seulement avec la poignée
Apertura sólo con tirador
Öffnung nur mit Griff

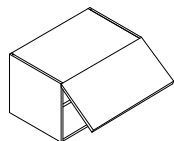

P/D	L/W	CODICE	0	1	2	3	4	5	6	7	8	9	10
57	90	KSV400570904	319	331	366	412	459	467	534	619	762	915	965
57	120	KSV400571204	329	341	378	425	473	481	550	637	786	944	994

Maggiorazione per apertura elettrica anta vasistas PUNTI 467

Surcharge for electric vasistas door opening | Supplément pour l'ouverture électrique de la porte vasistas | Recargo para apertura eléctrica puerta abatible | Aufpreis für die elektrische Öffnung der Klapptür

Basi con maniglia
Base units with handle

Basi con gola
Base units with groove

Colonne
Tall units

Pensili
Wall units

Elementi speciali
Special elements

Maniglie gole zoccoli
Handles grooves plinth

Illuminazione
Lighting

Accessori
Accessories

Componenti e meccanismi
Components e mechanism

PENSILI SOPRACOLONNA VETRINA

H 39

Overhead cabinets
Armoires suspendues
Overhead cabinets
Hängeschränke

Sopracolonna vetrina 1 anta

Overcabinet 1 door
Placard 1 porte
Vitrina sobre columna 1 puerta
Hängeschränk 1 Tür

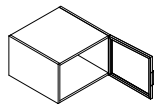

P/D	L/W	CODICE	0	1	2	3	4	5	6	7	8	9	10
57	45	KSW010390454	376	404	507	692	-	-	-	-	-	-	-
57	60	KSW010390604	399	428	538	733	-	-	-	-	-	-	-

Sopracolonna vetrina 2 ante

Showcase 2 doors
Vitrine 2 portes
Vitrina sobre columna 2 puertas
Schaukasten 2 Türen

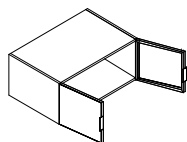

P/D	L/W	CODICE	0	1	2	3	4	5	6	7	8	9	10
57	90	KSW020390904	677	728	914	1.246	-	-	-	-	-	-	-

PENSILI SOPRACOLONNA VETRINA

H 45,5

Overhead cabinets
Armoires suspendues
Overhead cabinets
Hängeschränke

Sopracolonna vetrina 1 anta

Overcabinet 1 door
Placard 1 porte
Vitrina sobre columna 1 puerta
Hängeschränk 1 Tür

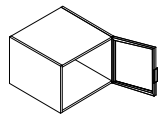

P/D	L/W	CODICE	0	1	2	3	4	5	6	7	8	9	10
57	45	KSW010450454	387	416	522	711	-	-	-	-	-	-	-
57	60	KSW010450604	410	441	554	755	-	-	-	-	-	-	-

Sopracolonna vetrina 2 ante

Showcase 2 doors
Vitrine 2 portes
Vitrina sobre columna 2 puertas
Schaukasten 2 Türen

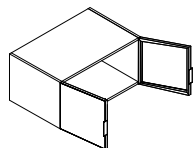

P/D	L/W	CODICE	0	1	2	3	4	5	6	7	8	9	10
57	90	KSW020450904	695	747	938	1.278	-	-	-	-	-	-	-

Basi con maniglia
Base units with handle

Basi con gola
Base units with groove

Colonne
Tall units

Pensili
Wall units

Elementi speciali
Special elements

Maniglie gole zoccoli
Handles grooves plinth

Illuminazione
Lighting

Accessori
Accessories

Componenti e meccanismi
Components e mechanism

PENSILI SOPRACOLONNA VETRINA

H. 57

Overhead cabinets
Armoires suspendues
Overhead cabinets
Hängeschränke

Sopracolonna vetrina 1 anta

Overcabinet 1 door
Placard 1 porte
Vitrina sobre columna 1 puerta
Hängeschränk 1 Tür

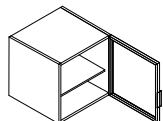

P/D	L/W	CODICE	0	1	2	3	4	5	6	7	8	9	10
57	45	KSW010570454	448	482	605	825	-	-	-	-	-	-	-
57	60	KSW010570604	490	527	661	902	-	-	-	-	-	-	-

Sopracolonna vetrina 2 ante

Showcase 2 doors
Vitrine 2 portes
Vitrina sobre columna 2 puertas
Schaukasten 2 Türen

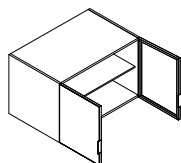

P/D	L/W	CODICE	0	1	2	3	4	5	6	7	8	9	10
57	90	KSW020570904	804	865	1.086	1.480	-	-	-	-	-	-	-

COLONNE COMPOSTE

Compound tall units
 Colonne composées
 Compound tall units
 Zusammengesetzte Hochschränke

Per colonna composta si intende colonna di serie + sovracolonna di serie + anta unica

Composite column means series column + series overcolumn + single sash
 Colonne composite signifie colonne en série + colonne en surplomb + vantail unique
 Columna compuesta quiere decir columna estándar + columna apilable estándar + puerta singular
 Kombi Schrank bedeutet Hochschrank + Haengeschränk + Einzeltür

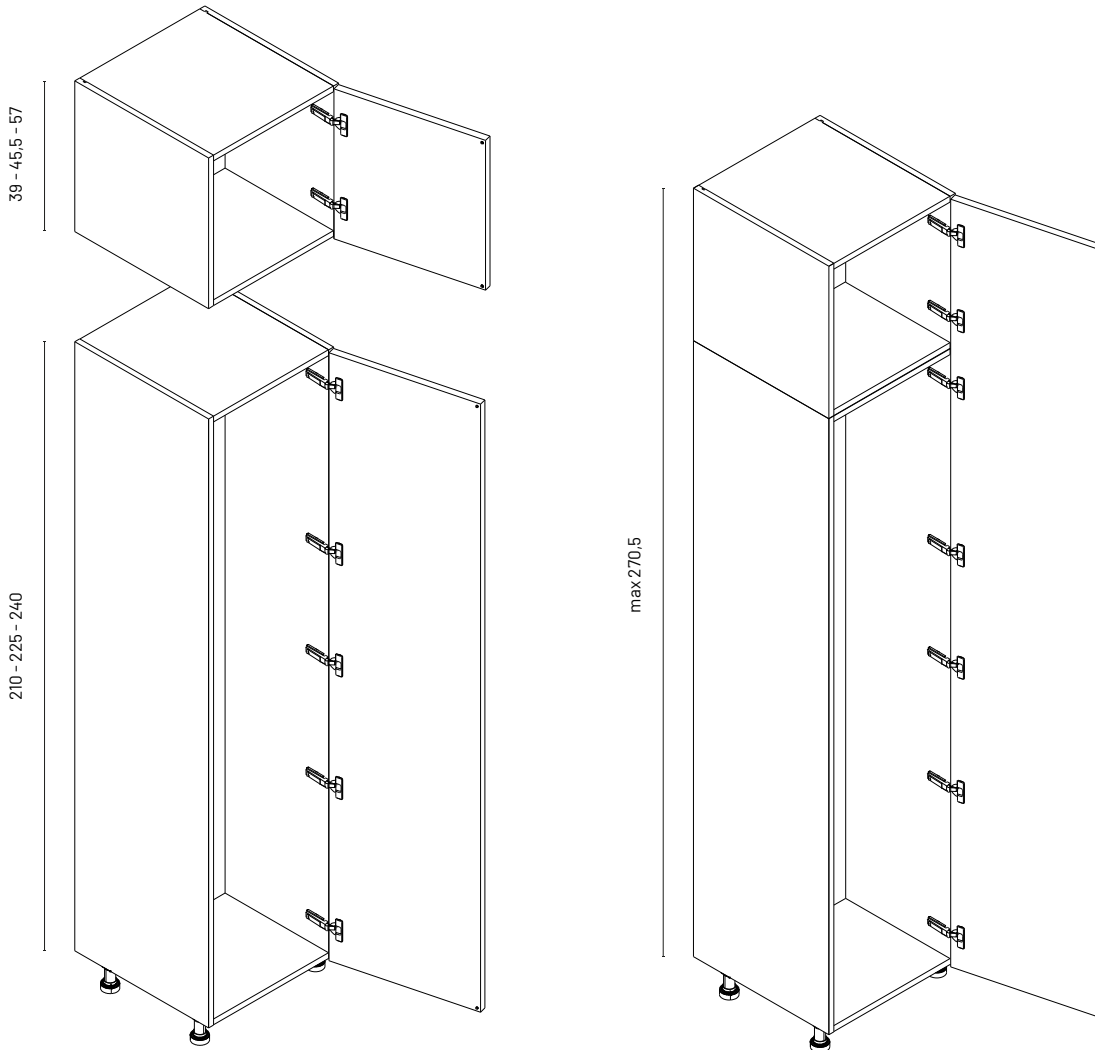

TOTALE PREZZO COLONNA COMPOSTA

Total price compound tall unit | Prix total colonne composée | Precio total columna compuesta | Gesamtpreis zusammengesetzte Spalte

COLONNE (- PREZZO ANTA)

Tall units (- door price)
 Colonne (- prix porte)
 Columnas (- precio puerta)
 Hochschränke (- Türpreis)

+

SOVRACOLONNA (- PREZZO ANTA)

Overcolumn (- door price)
 Surcolonne (- prix de l'ouvrant)
 Sobrecolumna (- precio puerta)
 Overcolumn (- Flügelpreis)

+

ANTA SINGOLA

Single door
 Porte simple
 Puerta singular
 Einzeltür

+

EVENTUALI RIDUZIONI SUI MOBILI

Any reductions on furniture
 Réductions possibles sur les meubles
 Eventuales reducciones en los muebles
 Mögliche Sonderanfertigungen

NOTA: le scocche vengono spedite singolarmente con l'anta unica a parte | NOTE: the shells are shipped individually with the single sash separately | NOTE : les coques sont expédiées individuellement avec la porte simple séparément | NOTA: las estructuras se envían individualmente con la puerta entera por separado | HINWEIS: Die Strukturen werden einzeln mit der Tür separat geliefert

Basi con maniglia
 Base units with handle

Basi con gola
 Base units with groove

Colonne
 Tall units

Pensili
 Wall units

Elementi speciali
 Special elements

Maniglie gole zoccoli
 Handles grooves plinth

Illuminazione
 Lighting

Accessori
 Accessories

Componenti e meccanismi
 Components e mechanism

PENSILI

Wall cabinets
Modules suspendus
Colgantes
Hängeschränke

H. 39	P. 189
<ul style="list-style-type: none">PENSILI Wall cabinets Modules suspendus Colgantes Hängeschränke P. 189PENSILI SCOLAPIATTI Dish drainer wall units Modules suspendus avec égouttoir à vaisselle Colgantes escurridores Hängeschränke mit Abtropfflächen P. 191PENSILI CAPPA Wall cabinets hood Modules suspendus hotte Colgantes con campana Hängeschränke Haube P. 192PENSILI VETRINA Display cabinets Vitrines Vitriñas colgantes Hängeschränke mit Glasstür P. 193	
H. 45,5	P. 194
<ul style="list-style-type: none">PENSILI Wall cabinets Modules suspendus Colgantes Hängeschränke P. 194PENSILI SCOLAPIATTI Dish drainer wall units Modules suspendus avec égouttoir à vaisselle Colgantes escurridores Hängeschränke mit Abtropfflächen P. 196PENSILI CAPPA Wall cabinets hood Modules suspendus hotte Colgantes con campana Hängeschränke Haube P. 197PENSILI COMPOSTI Composite wall units Modules suspendis compés Colgantes compuestos Kombi-Hängeschränke P. 198PENSILI VETRINA Display cabinets Vitrines Vitriñas colgantes Hängeschränke mit Glasstür P. 201	
H. 57	P. 202
<ul style="list-style-type: none">PENSILI Wall cabinets Modules suspendus Colgantes Hängeschränke P. 202PENSILI SCOLAPIATTI Dish drainer wall units Modules suspendus avec égouttoir à vaisselle Colgantes escurridores Hängeschränke mit Abtropfflächen P. 205PENSILI CAPPA Wall cabinets hood Modules suspendus hotte Colgantes con campana Hängeschränke Haube P. 207PENSILI COMPOSTI Composite wall units Modules suspendis compés Colgantes compuestos Kombi-Hängeschränke P. 208PENSILI VETRINA Display cabinets Vitrines Vitriñas colgantes Hängeschränke mit Glasstür P. 211	
H. 72	P. 212
<ul style="list-style-type: none">PENSILI Wall cabinets Modules suspendus Colgantes Hängeschränke P. 212PENSILI SCOLAPIATTI Dish drainer wall units Modules suspendus avec égouttoir à vaisselle Colgantes escurridores Hängeschränke mit Abtropfflächen P. 215PENSILI CAPPA Wall cabinets hood Modules suspendus hotte Colgantes con campana Hängeschränke Haube P. 217PENSILI VETRINA Display cabinets Vitrines Vitriñas colgantes Hängeschränke mit Glasstür P. 219	
H. 87	P. 220
<ul style="list-style-type: none">PENSILI Wall cabinets Modules suspendus Colgantes Hängeschränke P. 220PENSILI SCOLAPIATTI Dish drainer wall units Modules suspendus avec égouttoir à vaisselle Colgantes escurridores Hängeschränke mit Abtropfflächen P. 223PENSILI CAPPA Wall cabinets hood Modules suspendus hotte Colgantes con campana Hängeschränke Haube P. 225PENSILI VETRINA Display cabinets Vitrines Vitriñas colgantes Hängeschränke mit Glasstür P. 227	
H. 102	P. 228
<ul style="list-style-type: none">PENSILI Wall cabinets Modules suspendus Colgantes Hängeschränke P. 228PENSILI SCOLAPIATTI Dish drainer wall units Modules suspendus avec égouttoir à vaisselle Colgantes escurridores Hängeschränke mit Abtropfflächen P. 231PENSILI CAPPA Wall cabinets hood Modules suspendus hotte Colgantes con campana Hängeschränke Haube P. 233PENSILI VETRINA Display cabinets Vitrines Vitriñas colgantes Hängeschränke mit Glasstür P. 235	

Basi con maniglia
Base units with handle

Basi con gola
Base units with groove

Colonne
Tall units

Pensili
Wall units

Elementi speciali
Special elements

Maniglie gole zoccoli
Handles grooves plinth

Illuminazione
Lighting

Accessori
Accessories

Componenti e meccanismi
Components e mechanism

MAGGIORAZIONI PENSILI

Overhead surcharges
Supplément pour papier peint
Recargos por papel pintado
Zuschläge für Tapeten

Consulta l'elenco completo delle maggiorazioni a pag. 30

See the full list of surcharges on page 30

Voir la liste complète des suppléments à la page 30

Consulte la lista completa de recargos a la página 30

Siehe die vollständige Liste der Zuschläge auf Seite 30

MAGGIORAZIONI ENHANCEMENTS SUPPLÉMENTS RECARGOS AUFPREISEN	PUNTI POINTS PUNTOS PUNKTE
CAPPA FINITURA INOX PER PIANO INDUZIONE For stainless steel finish hood for induction cooktop Pour hotte en acier inoxydable pour plaque de cuisson à induction Para campana con acabado en acero inoxidable para placa de inducción Für Edelstahl-Dunstabzugshaube für Induktionskochfeld	100
CAPPA FINITURA NERO PER PIANO INDUZIONE For black finish hood for induction cooktop Pour hotte à finition noire pour plaque à induction Para campana de acabado negro para placa de inducción Für schwarz lackierte Haube für Induktionskochfeld	150
CAPPA FINITURA NERO PER PIANO GAS For black finish hood for gas top Pour hotte à finition noire pour plaque de cuisson au gaz Para campana en acabado negro para encimera de gas Für schwarz lackierte Haube für Gaskochfeld	50
APERTURA ELETTRICA ANTA VASISTAS For electric vasistas door opening Pour l'ouverture de la porte vasistas à commande électrique Para apertura eléctrica de puertas vasistas Für elektrisch betriebene vasistas Türöffnung	467
APERTURA ELETTRICA ANTA SALISCENDI For electric up-and-down sash opening Pour l'ouverture électrique de la porte de haut en bas Para apertura eléctrica de puerta basculante Für elektrische Türöffnung nach oben und unten	429
APERTURA ELETTRICA ANTE PACCHETTO VERTICALE For electrically opening vertical package doors Pour les portes de colis verticales à ouverture électrique Para puertas de paquetes verticales de apertura eléctrica Für elektrisch öffnende vertikale Pakettüren	429
TRASFORMATORE PER APERTURA ELETTRICA 220V (UE) / 110V (UL - USA) Transformer for electrical opening 220V (EU) / 110V (UL - USA) Transformateur pour ouverture électrique 220V (EU) / 110V (UL - USA) Transformador para apertura eléctrica 220V (EU) / 110V (UL - USA) Transformator für elektrische Öffnung 220V (EU) / 110V (UL - USA)	164

PENSILI

Wall cabinets
Modules suspendus
Colgantes
Hängeschränke

H. 39

Riempitivo per pensile con fianco

Wall unit filler with side
Fileur pour modules suspendus avec côté
Relleno para colgante con lateral
Füllung für Hängeschränk mit Ausseneite



P/D	L/W	CODICE	0	1	2	3	4	5	6	7	8	9	10
34	4-15	KPN900390151	95	106	109	126	134	142	155	182	219	263	303

Pensile 1 anta

Wall unit 1 door
module suspendu 1 porte
Colgante 1 puerta
Hängeschränk 1 Tür

Apertura con profilo o maniglia
Opening with profile or handle
Ouverture avec profil ou poignée
Apertura con perfil o tirador
Öffnung mit Profil oder Griff

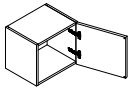

P/D	L/W	CODICE	0	1	2	3	4	5	6	7	8	9	10
34	45	KPN010390451	126	146	155	184	495	213	223	281	345	415	465

Pensile 2 ante

2 door wall unit
module suspendu 2 portes
Colgante 2 puertas
2-türiger Hängeschränk

Apertura con profilo o maniglia
Opening with profile or handle
Ouverture avec profil ou poignée
Apertura con perfil o tirador
Öffnung mit Profil oder Griff

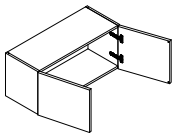

P/D	L/W	CODICE	0	1	2	3	4	5	6	7	8	9	10
34	90	KPN020390901	175	204	233	281	310	320	359	437	540	645	690

Basi con maniglia
Base units with handle

Basi con gola
Base units with groove

Colonne
Tall units

Pensili
Wall units

Elementi speciali
Special elements

Maniglie gole zoccoli
Handles grooves plinth

Illuminazione
Lighting

Accessori
Accessories

Componenti e meccanismi
Components e mechanism

PENSILI

Wall cabinets
Modules suspendus
Colgantes
Hängeschränke

H. 39

Pensile 1 vasistas

Wall unit 1 vasistas
module suspendu 1 vasistas
Colgante 1 puerta abatible
Hängeschränk 1 Klapptür

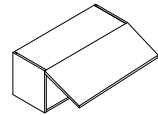

Apertura con profilo o maniglia
Opening with profile or handle
Ouverture avec profil ou poignée
Apertura con perfil o tirador
Öffnung mit Profil oder Griff

P/D	L/W	CODICE	0	1	2	3	4	5	6	7	8	9	10
34	45	KPN400390451	164	184	193	218	252	258	264	332	409	490	540
34	60	KPN400390601	201	222	236	265	301	306	322	392	484	581	631
34	75	KPN400390751	243	261	278	312	348	357	384	478	592	710	760
34	90	KPN400390901	283	299	321	359	397	407	446	564	698	837	887
34	105	KPN400391051	295	306	335	375	404	425	477	583	721	865	915
34	120	KPN400391201	305	309	345	393	440	451	510	593	733	879	829

PENSILI SCOLAPIATTI

Dish drainer wall units
 Modules suspendus avec égouttoir à vaisselle
 Colgantes escurridores
 Hängeschränke mit Abtropfflächen

H. 39

Pensile scolapiatti 1 vasistas

Dish drainer wall unit 1 vasistas
 Egouttoir à vaisselle mural 1 vasistas
 Colgante escurreplatos 1 p.abatible
 Geschirrabtropfer Hängeschrank 1 Klapptür

Apertura con profilo o maniglia
 Opening with profile or handle
 Ouverture avec profil ou poignée
 Apertura con perfil o tirador
 Öffnung mit Profil oder Griff

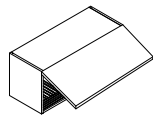

P/D	L/W	CODICE	0	1	2	3	4	5	6	7	8	9	10
34	60	KPS400390601	286	307	321	353	390	402	413	490	589	692	742
34	75	KPS400390751	326	61	371	406	448	458	482	584	705	831	881
34	90	KPS400390901	364	396	418	460	505	514	550	677	821	969	1.019
34	105	KPS400391051	409	440	468	511	538	564	619	732	880	1.033	1.083
34	120	KPS400391201	510	535	572	621	672	686	748	834	990	1.145	1.195

Basi con maniglia
 Base units with handle

Basi con gola
 Base units with groove

Colonne
 Tall units

Pensili
 Wall units

Elementi speciali
 Special elements

Maniglie gole zoccoli
 Handles grooves plinth

Illuminazione
 Lighting

Accessori
 Accessories

Componenti e meccanismi
 Components e mechanism

PENSILI CAPPA

Wall cabinets hood
Modules suspendus hotte
Colgantes con campana
Hängeschränke Haube

H. 39

Pensile cappa 1 vasistas

Wall-mounted hood 1 vasistas
module suspendu hotte 1 vasistas
Colgante campana 1 puerta abatible
Wandhaube 1 mit Klapptür

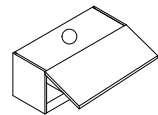

Apertura con profilo o maniglia
Opening with profile or handle
Ouverture avec profil ou poignée
Apertura con perfil o tirador
Öffnung mit Profil oder Griff

P/D	L/W	CODICE	0	1	2	3	4	5	6	7	8	9	10
34	60	KPC400390601	608	623	636	661	685	707	746	766	1.017	1.060	1.110
34	75	KPC400390751	629	645	662	690	718	744	784	809	1.070	1.110	1.160
34	90	KPC400390901	649	667	686	718	750	781	822	851	1.103	1.160	1.210
34	120	KPC400391201	746	769	792	831	872	913	954	989	1.248	1.333	1.373

Inclusa di serie cappa inox per piani a gas (per ulteriori tipologie vedere pag. 188)

Included as standard stainless steel hood for gas cooktops (for more types see p. 188) | Hotte standard en acier inoxydable pour plaques de cuisson à gaz incluse (pour d'autres types, voir page 188) | Campana estándar de acero inoxidable para placas de gas incluida (para más tipos, consulte la página 188) | Standard-Edelstahlhaube für Gaskochfelder inklusive (weitere Typen siehe Seite 188)

PENSILI VETRINA

Display cabinets
Vitrines
Vitrinas colgantes
Hängeschränke mit Glasstür

H. 39

Pensile vetrina 1 anta

Display cabinet 1 door
Vitrine suspendue 1 porte
Vitrina colgante 1 puerta
Hängeschränk 1 Glasstür

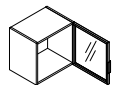

P/D	L/W	CODICE	0	1	2	3	4	5	6	7	8	9	10
34	45	KPV010390451	312	336	421	574	-	-	-	-	-	-	-
34	60	KPV010390601	331	356	447	609	-	-	-	-	-	-	-

Pensile vetrina 2 ante

2 door display cabinet
Vitrine suspendue 2 portes
Vitrina colgantede puertas
Hängeschränk 2 Glasstür

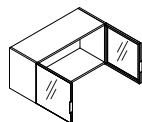

P/D	L/W	CODICE	0	1	2	3	4	5	6	7	8	9	10
34	90	KPV020390901	602	647	813	1.108	-	-	-	-	-	-	-

Basi con maniglia
Base units with handle

Basi con gola
Base units with groove

Colonne
Tall units

Pensili
Wall units

Elementi speciali
Special elements

Maniglie gole zoccoli
Handles grooves plinth

Illuminazione
Lighting

Accessori
Accessories

Componenti e meccanismi
Components e mechanism

PENSILI

Wall cabinets
Modules suspendus
Colgantes
Hängeschränke

H. 45,5

Riempitivo per pensile con fianco

Wall unit filler with side
Fileur pour modules suspendus avec côté
Relleno para colgante con lateral
Füllung für Hängeschränk mit Ausseneite



P/D	L/W	CODICE	0	1	2	3	4	5	6	7	8	9	10
34	4-15	KPN900450151	105	115	119	139	148	156	170	190	231	278	318

Pensile 1 anta

Wall unit 1 door
module suspendu 1 porte
Colgante 1 puerta
Hängeschränk 1 Tür

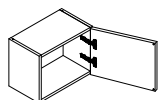

Apertura con profilo o maniglia
Opening with profile or handle
Ouverture avec profil ou poignée
Apertura con perfil o tirador
Öffnung mit Profil oder Griff

P/D	L/W	CODICE	0	1	2	3	4	5	6	7	8	9	10
34	45	KPN010450451	133	151	165	190	209	219	229	287	351	421	461
34	60	KPN010450601	144	159	184	222	230	256	286	345	423	509	549

Pensile 2 ante

2 door wall unit
module suspendu 2 portes
Colgante 2 puertas
2-türiger Hängeschränk

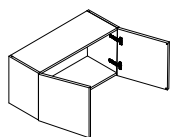

Apertura con profilo o maniglia
Opening with profile or handle
Ouverture avec profil ou poignée
Apertura con perfil o tirador
Öffnung mit Profil oder Griff

P/D	L/W	CODICE	0	1	2	3	4	5	6	7	8	9	10
34	90	KPN020450901	181	212	236	288	313	326	364	442	545	652	692

PENSILI

Wall cabinets
Modules suspendus
Colgantes
Hängeschränke

H. 45,5

Pensile 1 vasistas

Wall unit 1 vasistas
module suspendu 1 vasistas
Colgante 1 puerta abatible
Hängeschränk 1 Klapptür

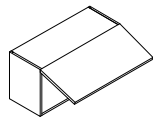

Apertura con profilo o maniglia
Opening with profile or handle
Ouverture avec profil ou poignée
Apertura con perfil o tirador
Öffnung mit Profil oder Griff

P/D	L/W	CODICE	0	1	2	3	4	5	6	7	8	9	10
34	45	KPN400450451	243	255	267	295	313	319	331	393	483	579	609
34	60	KPN400450601	274	288	307	337	372	380	402	469	575	689	729
34	75	KPN400450751	287	298	324	357	395	407	436	503	619	742	782
34	90	KPN400450901	299	307	341	378	416	435	469	537	662	793	833
34	105	KPN400451051	310	315	359	398	437	456	500	582	730	850	898
34	120	KPN400451201	332	337	379	417	457	480	538	629	777	930	970

Basi con maniglia
Base units with handle

Basi con gola
Base units with groove

Colonne
Tall units

Pensili
Wall units

Elementi speciali
Special elements

Maniglie gole zoccoli
Handles grooves plinth

Illuminazione
Lighting

Accessori
Accessories

Componenti e meccanismi
Components e mechanism

PENSILI SCOLAPIATTI

Dish drainer wall units
 Modules suspendus avec égouttoir à vaisselle
 Colgantes escurridores
 Hängeschränke mit Abtropfflächen

H. 45,5

Pensile scolapiatti 1 anta

Dish drainer wall unit 1 door
 Evier à vaisselle mural 1 porte
 Colgante escurridor 1 puerta
 Geschirrspülbecken Hängeschrank 1 Tür

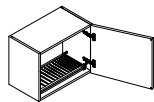

P/D	L/W	CODICE	0	1	2	3	4	5	6	7	8	9	10
34	60	KPS010450601	191	209	234	271	276	304	333	392	475	558	598

Apertura con profilo o maniglia
 Opening with profile or handle
 Ouverture avec profil ou poignée
 Apertura con perfil o tirador
 Öffnung mit Profil oder Griff

Pensile scolapiatti 2 ante

2 door dish rack
 Porte-vaisselle 2 portes
 Colgante escurridor 2 puertas
 2-türiger Geschirrständer

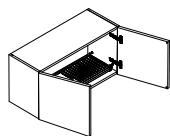

P/D	L/W	CODICE	0	1	2	3	4	5	6	7	8	9	10
34	90	KPS020450901	234	276	302	356	382	396	437	523	631	747	787

Apertura con profilo o maniglia
 Opening with profile or handle
 Ouverture avec profil ou poignée
 Apertura con perfil o tirador
 Öffnung mit Profil oder Griff

Pensile scolapiatti 1 vasistas

Dish drainer wall unit 1 vasistas
 Egouttoir à vaisselle mural 1 vasistas
 Colgante escurreplatos 1 p.abatible
 Geschirrabtropfer Hängeschrank 1 Klapptür

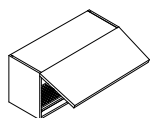

P/D	L/W	CODICE	0	1	2	3	4	5	6	7	8	9	10
34	60	KPS400450601	243	255	267	295	313	319	331	393	483	579	609
34	75	KPS400450751	274	288	307	337	372	380	402	469	575	689	739
34	90	KPS400450901	287	298	324	357	395	407	436	503	619	742	782
34	105	KPS400451051	299	307	341	378	416	435	469	537	662	793	833
34	120	KPS400451201	332	337	379	417	457	480	538	629	777	930	970

Apertura con profilo o maniglia
 Opening with profile or handle
 Ouverture avec profil ou poignée
 Apertura con perfil o tirador
 Öffnung mit Profil oder Griff

PENSILI CAPPA

Wall cabinets hood
Modules suspendus hotte
Colgantes con campana
Hängeschränke Haube

H. 45,5

Pensile cappa 1 anta

Wall unit hood 1 door
module suspendu hotte 1 porte
Colgante campana 1 puerta
Hängeschrank Haube 1 Tür

Apertura con profilo o maniglia
Opening with profile or handle
Ouverture avec profil ou poignée
Apertura con perfil o tirador
Öffnung mit Profil oder Griff

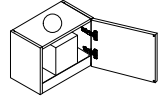

P/D	L/W	CODICE	0	1	2	3	4	5	6	7	8	9	10
34	60	KPC010450601	559	569	580	590	652	677	712	737	874	978	1.092

Inclusa di serie cappa inox per piani a gas (per ulteriori tipologie vedere pag. 188)

Included as standard stainless steel hood for gas cooktops (for more types see p. 188) | Hotte standard en acier inoxydable pour plaques de cuisson à gaz incluse (pour d'autres types, voir page 188) | Campana estándar de acero inoxidable para placas de gas incluida (para más tipos, consulte la página 188) | Standard-Edelstahlhaube für Gaskochfelder inklusive (weitere Typen siehe Seite 188)

Pensile cappa 2 ante

2 door hood wall unit
module suspendu hotte 2 portes
Colgante campana 2 puertas
2-türiger HaubenHängeschrank

Apertura con profilo o maniglia
Opening with profile or handle
Ouverture avec profil ou poignée
Apertura con perfil o tirador
Öffnung mit Profil oder Griff

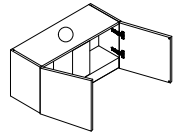

P/D	L/W	CODICE	0	1	2	3	4	5	6	7	8	9	10
34	90	KPC020450901	600	631	660	681	741	782	858	898	1.097	1.268	1.439
34	120	KPC020451201	681	719	756	781	853	903	972	1.022	1.238	1.423	1.607

Inclusa di serie cappa inox per piani a gas (per ulteriori tipologie vedere pag. 188)

Included as standard stainless steel hood for gas cooktops (for more types see p. 188) | Hotte standard en acier inoxydable pour plaques de cuisson à gaz incluse (pour d'autres types, voir page 188) | Campana estándar de acero inoxidable para placas de gas incluida (para más tipos, consulte la página 188) | Standard-Edelstahlhaube für Gaskochfelder inklusive (weitere Typen siehe Seite 188)

Pensile cappa 1 vasistas

Wall-mounted hood 1 vasistas
module suspendu hotte 1 vasistas
Colgante campana 1 puerta abatible
Wandhaube 1 mit Klapptür

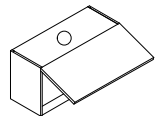

P/D	L/W	CODICE	0	1	2	3	4	5	6	7	8	9	10
34	60	KPC400450601	657	671	685	709	733	756	794	815	1.067	1.110	1.160
34	75	KPC400450751	677	694	710	738	766	792	832	857	1.120	1.160	1.210
34	90	KPC400450901	697	716	734	766	798	829	870	899	1.153	1.210	1.260
34	120	KPC400451201	794	818	840	880	921	961	1.002	1.038	1.298	1.383	1.423

Inclusa di serie cappa inox per piani a gas (per ulteriori tipologie vedere pag. 188)

Included as standard stainless steel hood for gas cooktops (for more types see p. 188) | Hotte standard en acier inoxydable pour plaques de cuisson à gaz incluse (pour d'autres types, voir page 188) | Campana estándar de acero inoxidable para placas de gas incluida (para más tipos, consulte la página 188) | Standard-Edelstahlhaube für Gaskochfelder inklusive (weitere Typen siehe Seite 188)

Basi con maniglia
Base units with handle

Basi con gola
Base units with groove

Colonne
Tall units

Pensili
Wall units

Elementi speciali
Special elements

Maniglie gole zoccoli
Handles grooves plinth

Illuminazione
Lighting

Accessori
Accessories

Componenti e meccanismi
Components e mechanism

PENSILI COMPOSTI

Composite wall units
Modules suspendis compôsés
Colgantes compuestos
Kombi-Hängeschränke

H. 45,5

Pensile composto (2 vani ripiani) 1 vasistas

Composite wall unit (2 shelf compartments) 1 vasistas
Elément mural composite (2 compartiments d'étagère) 1 vasistas
Colgante compuesto (1 compartimentos baldas) 1 abatible
Kombi-Hängeschränk (2 Regalfächer) 1 Klapptür

Apertura con profilo o maniglia
Opening with profile or handle
Ouverture avec profil ou poignée
Apertura con perfil o tirador
Öffnung mit Profil oder Griff

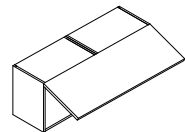

P/D	L/W	CODICE	0	1	2	3	4	5	6	7	8	9	10
34	120	KPW400451201	463	499	543	606	637	692	728	807	876	1.051	1.191

Pensile composto (2 vani ripiani) 1 vasistas

Composite wall unit (2 shelf compartments) 1 vasistas
Elément mural composite (2 compartiments d'étagère) 1 vasistas
Colgante compuesto (1 compartimentos baldas) 1 abatible
Kombi-Hängeschränk (2 Regalfächer) 1 Klapptür

Apertura con profilo o maniglia
Opening with profile or handle
Ouverture avec profil ou poignée
Apertura con perfil o tirador
Öffnung mit Profil oder Griff

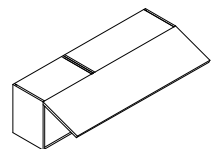

P/D	L/W	CODICE	0	1	2	3	4	5	6	7	8	9	10
34	150	KPW400451501	478	515	589	668	702	762	800	888	963	1.156	1.306

Non disponibile nelle finiture Fenix NTA, cannelé, acciaio inox e metal.

Not available in Fenix NTA, cannelé, stainless steel and metal finishes. | Non disponible dans les finitions Fenix NTA, cannelé, acier inoxydable et métal. | No disponible en los acabados Fenix NTA, cannelé, acero inoxidable y metal. | Nicht erhältlich in den Ausführungen Fenix NTA, Cannelé, Edelstahl und Metall.

Pensile composto (1 vano ripiani + cappa) 1 vasistas

Composite wall unit (1 shelf compartment + hood) 1 vasistas
Elément mural composite (1 compartiment d'étagère + hotte) 1 vasistas
Colgante compuesto (1 compart. baldas + campana) 1 abatible
Kombi-Hängeschränk (1 Regalfach + Abzugshaube) 1 Klapptür

Apertura con profilo o maniglia
Opening with profile or handle
Ouverture avec profil ou poignée
Apertura con perfil o tirador
Öffnung mit Profil oder Griff

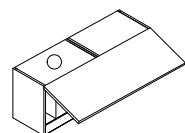

P/D	L/W	CODICE	0	1	2	3	4	5	6	7	8	9	10
34	120	KPY400451201	930	959	991	1.046	1.106	1.136	1.196	1.283	1.642	1.799	1.889

Inclusa di serie cappa inox per piani a gas (per ulteriori tipologie vedere pag. 188)

Included as standard stainless steel hood for gas cooktops (for more types see p. 188) | Hotte standard en acier inoxydable pour plaques de cuisson à gaz incluse (pour d'autres types, voir page 188) | Campana estándar de acero inoxidable para placas de gas incluida (para más tipos, consulte la página 188) | Standard-Edelstahlhaube für Gaskochfelder inklusive (weitere Typen siehe Seite 188)

PENSILI COMPOSTI

H. 45,5

Composite wall units
Modules suspendis compósés
Colgantes compuestos
Kombi-Hängeschränke

Pensile composto (1 vano ripiani + cappa) 1 vasistas

Composite wall unit (1 shelf compartment + hood) 1 vasistas
Elément mural composite (1 compartiment d'étagère + hotte) 1 vasistas
Colgante compuesto (1 compart. baldas + campana) 1 abatible
Kombi-Hängeschränk (1 Regalfach + Abzugshaube) 1 Klapptür

Apertura con profilo o maniglia
Opening with profile or handle
Ouverture avec profil ou poignée
Apertura con perfil o tirador
Öffnung mit Profil oder Griff

P/D	L/W	CODICE	0	1	2	3	4	5	6	7	8	9	10
34	150	KPY400451501	971	1.004	1.041	1.103	1.171	1.210	1.272	1.368	1.728	1.899	1.989

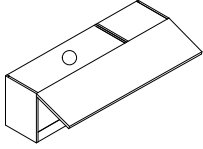

Inclusa di serie cappa inox per piani a gas (per ulteriori tipologie vedere pag. 188)

Included as standard stainless steel hood for gas cooktops (for more types see p. 188) | Hotte standard en acier inoxydable pour plaques de cuisson à gaz incluse (pour d'autres types, voir page 188) | Campana estándar de acero inoxidable para placas de gas incluida (para más tipos, consulte la página 188) | Standard-Edelstahlhaube für Gaskochfelder inklusive (weitere Typen siehe Seite 188)

Non disponibile nelle finiture Fenix NTA, cannelé, acciaio inox e metal.

Not available in Fenix NTA, cannelé, stainless steel and metal finishes. | Non disponible dans les finitions Fenix NTA, cannelé, acier inoxydable et métal. | No disponible en los acabados Fenix NTA, cannelé, acero inoxidable y metal. | Nicht erhältlich in den Ausführungen Fenix NTA, Cannelé, Edelstahl und Metall.

Pensile composto (2 vani ripiani + cappa) 1 vasistas

Composite wall unit (2 shelf compartments + hood) 1 vasistas
Unité murale composite (2 compartiments d'étagère + hotte) 1 vasistas
Colgante compuesto (2 compart. baldas + campana) 1 abatible
Kombi-Hängeschränk (2 Regalfächer + Abzugshaube) 1 Klapptür

Apertura con profilo o maniglia
Opening with profile or handle
Ouverture avec profil ou poignée
Apertura con perfil o tirador
Öffnung mit Profil oder Griff

P/D	L/W	CODICE	0	1	2	3	4	5	6	7	8	9	10
34	150	KPZ400451501	1.029	1.062	1.099	1.161	1.229	1.268	1.336	1.426	1.788	1.959	2.059

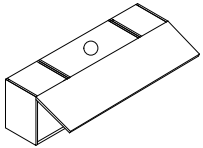

Inclusa di serie cappa inox per piani a gas (per ulteriori tipologie vedere pag. 188)

Included as standard stainless steel hood for gas cooktops (for more types see p. 188) | Hotte standard en acier inoxydable pour plaques de cuisson à gaz incluse (pour d'autres types, voir page 188) | Campana estándar de acero inoxidable para placas de gas incluida (para más tipos, consulte la página 188) | Standard-Edelstahlhaube für Gaskochfelder inklusive (weitere Typen siehe Seite 188)

Non disponibile nelle finiture Fenix NTA, cannelé, acciaio inox e metal.

Not available in Fenix NTA, cannelé, stainless steel and metal finishes. | Non disponible dans les finitions Fenix NTA, cannelé, acier inoxydable et métal. | No disponible en los acabados Fenix NTA, cannelé, acero inoxidable y metal. | Nicht erhältlich in den Ausführungen Fenix NTA, Cannelé, Edelstahl und Metall.

Pensile composto (2 vani ripiani + scolapiatti) 1 vasistas

Composite wall unit (2 shelf compartments + dish rack) 1 vasistas
Elément mural composite (2 compartiments d'étagère + support de vaisselle) 1 vasistas
Colgante compuesto (2 compart. baldas + escurridor) 1 abatible
Kombi-Hängeschränk (2 Regalfächer + Geschirrschubkast) 1 Klapptür

Apertura con profilo o maniglia
Opening with profile or handle
Ouverture avec profil ou poignée
Apertura con perfil o tirador
Öffnung mit Profil oder Griff

P/D	L/W	CODICE	0	1	2	3	4	5	6	7	8	9	10
34	120	KPX400451201	530	569	619	684	720	781	823	911	976	1.185	1.305

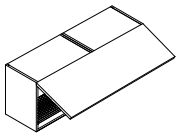

Basi con maniglia
Base units with handle

Basi con gola
Base units with groove

Colonne
Tall units

Pensili
Wall units

Elementi speciali
Special elements

Maniglie gole zoccoli
Handles grooves plinth

Illuminazione
Lighting

Accessori
Accessories

Componenti e meccanismi
Components e mechanism

PENSILI COMPOSTI

Composite wall units
Modules suspendis compvés
Colgantes compuestos
Kombi-Hängeschränke

H. 45,5

Pensile composto (2 vani ripiani + scolapiatti) 1 vasistas

Composite wall unit (2 shelf compartments + dish rack) 1 vasistas
Elément mural composite (2 compartiments d'étagère + support de vaisselle) 1 vasistas
Colgante compuesto (2 compart. baldas + escurridor) 1 abatible
Kombi-Hängeschränk (2 Regalfächer + Geschirrschubkast) 1 Klapptür

Apertura con profilo o maniglia
Opening with profile or handle
Ouverture avec profil ou poignée
Apertura con perfil o tirador
Öffnung mit Profil oder Griff

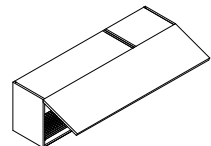

P/D	L/W	CODICE	0	1	2	3	4	5	6	7	8	9	10
34	150	KPX400451501	612	652	729	812	853	925	973	1.081	1.171	1.404	1.554

Non disponibile nelle finiture Fenix NTA, canneté, acciaio inox e metal.

Not available in Fenix NTA, canneté, stainless steel and metal finishes. | Non disponible dans les finitions Fenix NTA, canneté, acier inoxydable et métal. | No disponible en los acabados Fenix NTA, canneté, acero inoxidable y metal. | Nicht erhältlich in den Ausführungen Fenix NTA, Cannelé, Edelstahl und Metall.

PENSILI VETRINA

H. 45,5

Display cabinets
Vitrines
Vitrinas colgantes
Hängeschränke mit Glasstür

Pensile vetrina 1 anta

Display cabinet 1 door
Vitrine suspendue 1 porte
Vitrina colgante 1 puerta
Hängeschränk 1 Glasstür

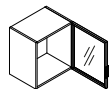

P/D	L/W	CODICE	0	1	2	3	4	5	6	7	8	9	10
34	45	KPV010450451	320	344	432	589	-	-	-	-	-	-	-
34	60	KPV010450601	340	366	459	626	-	-	-	-	-	-	-

Pensile vetrina 2 ante

2 door display cabinet
Vitrine suspendue 2 portes
Vitrina colgantede puertas
Hängeschränk 2 Glasstür

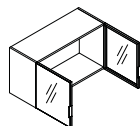

P/D	L/W	CODICE	0	1	2	3	4	5	6	7	8	9	10
34	90	KPV020450901	616	663	832	1.134	-	-	-	-	-	-	-

Basi con maniglia
Base units with handle

Basi con gola
Base units with groove

Colonne
Tall units

Pensili
Wall units

Elementi speciali
Special elements

Maniglie gole zoccoli
Handles grooves plinth

Illuminazione
Lighting

Accessori
Accessories

Componenti e meccanismi
Components e mechanism

PENSILI

Wall cabinets
Modules suspendus
Colgantes
Hängeschränke

H. 57

Riempitivo per pensile con fianco

Wall unit filler with side
Fileur pour modules suspendus avec côté
Relleno para colgante con lateral
Füllung für Hängeschränk mit Ausseneite



P/D	L/W	CODICE	0	1	2	3	4	5	6	7	8	9	10
34	4-15	KPN900570151	111	123	126	147	156	165	179	199	242	289	329

Pensile 1 anta

Wall unit 1 door
module suspendu 1 porte
Colgante 1 puerta
Hängeschränk 1 Tür

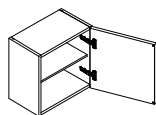

Apertura con profilo o maniglia
Opening with profile or handle
Ouverture avec profil ou poignée
Apertura con perfil o tirador
Öffnung mit Profil oder Griff

P/D	L/W	CODICE	0	1	2	3	4	5	6	7	8	9	10
34	45	KPN010570451	133	157	174	203	225	236	253	316	391	467	541
34	60	KPN010570601	144	170	189	230	252	270	296	365	451	541	615

Pensile 2 ante

2 door wall unit
module suspendu 2 portes
Colgante 2 puertas
2-türiger Hängeschränk

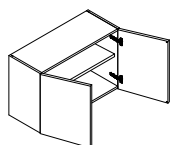

Apertura con profilo o maniglia
Opening with profile or handle
Ouverture avec profil ou poignée
Apertura con perfil o tirador
Öffnung mit Profil oder Griff

P/D	L/W	CODICE	0	1	2	3	4	5	6	7	8	9	10
34	90	KPN020570901	182	220	252	311	337	372	396	521	643	772	846

PENSILI

Wall cabinets
Modules suspendus
Colgantes
Hängeschränke

H. 57

Pensile 1 vasistas

Wall unit 1 vasistas
module suspendu 1 vasistas
Colgante 1 puerta abatible
Hängeschränk 1 Klapptür

Apertura con profilo o maniglia
Opening with profile or handle
Ouverture avec profil ou poignée
Apertura con perfil o tirador
Öffnung mit Profil oder Griff

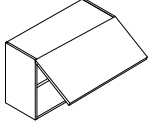

P/D	L/W	CODICE	0	1	2	3	4	5	6	7	8	9	10
34	45	KPN400570451	288	298	313	344	375	382	405	469	580	695	745
34	60	KPN400570601	299	307	328	367	404	413	443	514	638	763	813
34	75	KPN400570751	307	319	346	390	430	439	492	595	736	881	931
34	90	KPN400570901	319	331	366	412	459	467	534	619	762	915	965
34	105	KPN400571051	335	343	386	441	484	495	557	631	782	939	989
34	120	KPN400571201	349	358	408	467	507	520	571	649	804	964	1.014

Pensile 1 anta saliscendi

Wall unit 1 door
module suspendu 1 porte des hauts et des bas
Colgante 1 puerta
Hängeschränk 1 Tür

Apertura con profilo o maniglia
Opening with profile or handle
Ouverture avec profil ou poignée
Apertura con perfil o tirador
Öffnung mit Profil oder Griff

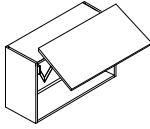

P/D	L/W	CODICE	0	1	2	3	4	5	6	7	8	9	10
34	60	KPN460570601	326	335	354	393	431	439	469	542	675	810	860
34	75	KPN460570751	336	349	373	424	459	467	518	635	787	945	995
34	90	KPN460570901	346	358	392	439	485	495	562	646	798	958	1.008
34	105	KPN460571051	362	375	416	467	509	524	583	670	828	995	1.045
34	120	KPN460571201	375	383	435	495	534	543	599	674	839	1.004	1.054

Pensile angolo 2 ante

Corner wall unit 2 doors
module suspendu d'angle 2 portes
Colgante ángulo 2 puertas
Eck-Hängeschränk 2 Türen

Apertura con profilo o maniglia
Opening with profile or handle
Ouverture avec profil ou poignée
Apertura con perfil o tirador
Öffnung mit Profil oder Griff

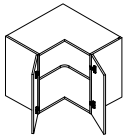

P/D	L/W	CODICE	0	1	2	3	4	5	6	7	8	9	10
65	65	KPA020570656	224	236	247	304	338	345	358	439	544	652	692

Basi con maniglia
Base units with handle

Basi con gola
Base units with groove

Colonne
Tall units

Pensili
Wall units

Elementi speciali
Special elements

Maniglie gole zoccoli
Handles grooves plinth

Illuminazione
Lighting

Accessori
Accessories

Componenti e meccanismi
Components e mechanism

PENSILI

Wall cabinets
Modules suspendus
Colgantes
Hängeschränke

H. 57

Pensile angolo 1 anta

Corner wall unit 1 door
module suspendu d'angle 1 porte
Colgante ángulo 1 puerta
Eck-Hängeschränk 1 Tür

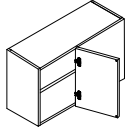

Apertura con profilo o maniglia
Opening with profile or handle
Ouverture avec profil ou poignée
Apertura con perfil o tirador
Öffnung mit Profil oder Griff

P/D	L/W	CODICE	0	1	2	3	4	5	6	7	8	9	10
34	95	KPA010570951D/S	204	245	281	346	375	414	441	578	716	858	908

PENSILI SCOLAPIATTI

H. 57

Dish drainer wall units
 Modules suspendus avec égouttoir à vaisselle
 Colgantes escurridores
 Hängeschränke mit Abtropfflächen

Pensile scolapiatti 1 vasistas

Dish drainer wall unit 1 vasistas
 Egouttoir à vaisselle mural 1 vasistas
 Colgante escurreplatos 1 p.abatible
 Geschirrabtropfer Hängeschrank 1 Klapptür

Apertura con profilo o maniglia
 Opening with profile or handle
 Ouverture avec profil ou poignée
 Apertura con perfil o tirador
 Öffnung mit Profil oder Griff

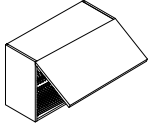

P/D	L/W	CODICE	0	1	2	3	4	5	6	7	8	9	10
34	60	KPS400570601	361	372	392	434	471	483	514	589	721	856	956
34	75	KPS400570751	375	386	414	463	503	517	566	679	828	985	1.085
34	90	KPS400570901	390	401	438	491	536	550	618	705	861	1.024	1.124
34	105	KPS400571051	405	415	463	518	569	583	643	725	885	1.051	1.151
34	120	KPS400571201	544	560	609	660	705	722	785	853	1.031	1.203	1.303

Pensile scolapiatti 1 anta saliscendi

Dish drainer wall unit 1 door lift-up
 Unité murale d'égouttage 1 porte relevable
 Colgante escurridor 1 puerta elevable
 Geschirrabtropfer Hängeschrank 1 Tür nach oben

Apertura con profilo o maniglia
 Opening with profile or handle
 Ouverture avec profil ou poignée
 Apertura con perfil o tirador
 Öffnung mit Profil oder Griff

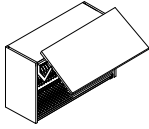

P/D	L/W	CODICE	0	1	2	3	4	5	6	7	8	9	10
34	60	KPS460570601	649	738	811	904	981	1.030	1.126	1.289	1.561	1.872	1.922
34	75	KPS460570751	404	415	443	489	534	547	595	678	831	986	1.086
34	90	KPS460570901	420	432	467	515	566	580	646	736	900	1.068	1.168
34	105	KPS460571051	493	517	553	601	619	646	704	821	993	1.167	1.267
34	120	KPS460571201	566	579	627	688	733	751	800	882	1.059	1.235	1.335

Pensile scolapiatti 1 anta

Dish drainer wall unit 1 door
 Evier à vaisselle mural 1 porte
 Colgante escurridor 1 puerta
 Geschirrspülbecken Hängeschrank 1 Tür

Apertura con profilo o maniglia
 Opening with profile or handle
 Ouverture avec profil ou poignée
 Apertura con perfil o tirador
 Öffnung mit Profil oder Griff

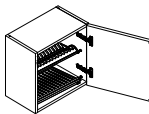

P/D	L/W	CODICE	0	1	2	3	4	5	6	7	8	9	10
34	45	KPS010570451	187	211	229	259	283	297	312	381	461	544	614
34	60	KPS010570601	200	225	244	286	311	331	356	433	524	619	701

Basi con maniglia
 Base units with handle

Basi con gola
 Base units with groove

Colonne
 Tall units

Pensili
 Wall units

Elementi speciali
 Special elements

Maniglie gole zoccoli
 Handles grooves plinth

Illuminazione
 Lighting

Accessori
 Accessories

Componenti e meccanismi
 Components e mechanism

PENSILI SCOLAPIATTI

Dish drainer wall units
Modules suspendus avec égouttoir à vaisselle
Colgantes escurridores
Hängeschränke mit Abtropfflächen

H. 57

Pensile scolapiatti 2 ante

2 door dish rack
Porte-vaisselle 2 portes
Colgante escurridor 2 puertas
2-türiger Geschirrständer

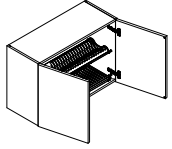

Apertura con profilo o maniglia
Opening with profile or handle
Ouverture avec profil ou poignée
Apertura con perfil o tirador
Öffnung mit Profil oder Griff

P/D	L/W	CODICE	0	1	2	3	4	5	6	7	8	9	10
34	90	KPS020570901	246	285	319	381	408	449	471	605	734	871	941

PENSILI CAPPA

Wall cabinets hood
Modules suspendus hotte
Colgantes con campana
Hängeschränke Haube

H. 57

Pensile cappa 1 anta

Wall unit hood 1 door
module suspendu hotte 1 porte
Colgante campana 1 puerta
Hängeschrank Haube 1 Tür

Apertura con profilo o maniglia
Opening with profile or handle
Ouverture avec profil ou poignée
Apertura con perfil o tirador
Öffnung mit Profil oder Griff

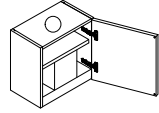

P/D	L/W	CODICE	0	1	2	3	4	5	6	7	8	9	10
34	60	KPC010570601	588	598	609	619	681	706	741	766	899	1.008	1.117

Inclusa di serie cappa inox per piani a gas (per ulteriori tipologie vedere pag. 188)

Included as standard stainless steel hood for gas cooktops (for more types see p. 188) | Hotte standard en acier inoxydable pour plaques de cuisson à gaz incluse (pour d'autres types, voir page 188) | Campana estándar de acero inoxidable para placas de gas incluida (para más tipos, consulte la página 188) | Standard-Edelstahlhaube für Gaskochfelder inklusive (weitere Typen siehe Seite 188)

Pensile cappa 2 ante

2 door hood wall unit
module suspendu hotte 2 portes
Colgante campana 2 puertas
2-türiger HaubenHängeschrank

Apertura con profilo o maniglia
Opening with profile or handle
Ouverture avec profil ou poignée
Apertura con perfil o tirador
Öffnung mit Profil oder Griff

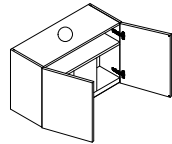

P/D	L/W	CODICE	0	1	2	3	4	5	6	7	8	9	10
34	90	KPC020570901	649	679	708	729	790	830	907	947	1.254	1.318	1.530
34	120	KPC020571201	729	767	804	829	901	952	1.020	1.071	1.397	1.473	1.769

Inclusa di serie cappa inox per piani a gas (per ulteriori tipologie vedere pag. 188)

Included as standard stainless steel hood for gas cooktops (for more types see p. 188) | Hotte standard en acier inoxydable pour plaques de cuisson à gaz incluse (pour d'autres types, voir page 188) | Campana estándar de acero inoxidable para placas de gas incluida (para más tipos, consulte la página 188) | Standard-Edelstahlhaube für Gaskochfelder inklusive (weitere Typen siehe Seite 188)

Pensile cappa 1 vasistas

Wall-mounted hood 1 vasistas
module suspendu hotte 1 vasistas
Colgante campana 1 puerta abatible
Wandhaube 1 mit Klapptür

Apertura con profilo o maniglia
Opening with profile or handle
Ouverture avec profil ou poignée
Apertura con perfil o tirador
Öffnung mit Profil oder Griff

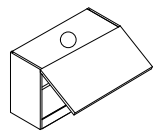

P/D	L/W	CODICE	0	1	2	3	4	5	6	7	8	9	10
34	60	KPC400570601	692	708	725	750	782	809	843	867	1.113	1.231	1.350
34	75	KPC400570751	715	734	75	783	821	854	890	921	1.196	1.306	1.417
34	90	KPC400570901	738	760	783	816	859	897	938	973	1.254	1.381	1.509
34	120	KPC400571201	821	849	876	917	973	1.024	1.077	1.124	1.424	1.586	1.748

Inclusa di serie cappa inox per piani a gas (per ulteriori tipologie vedere pag. 188)

Included as standard stainless steel hood for gas cooktops (for more types see p. 188) | Hotte standard en acier inoxydable pour plaques de cuisson à gaz incluse (pour d'autres types, voir page 188) | Campana estándar de acero inoxidable para placas de gas incluida (para más tipos, consulte la página 188) | Standard-Edelstahlhaube für Gaskochfelder inklusive (weitere Typen siehe Seite 188)

Basi con maniglia
Base units with handle

Basi con gola
Base units with groove

Colonne
Tall units

Pensili
Wall units

Elementi speciali
Special elements

Maniglie gole zoccoli
Handles grooves plinth

Illuminazione
Lighting

Accessori
Accessories

Componenti e meccanismi
Components e mechanism

PENSILI COMPOSTI

Composite wall units
Modules suspendis compôsés
Colgantes compuestos
Kombi-Hängeschränke

H. 57

Pensile composto (2 vani ripiani) 1 vasistas

Composite wall unit (2 shelf compartments) 1 vasistas
Elément mural composite (2 compartiments d'étagère) 1 vasistas
Colgante compuesto (1 compartimentos baldas) 1 abatible
Kombi-Hängeschränk (2 Regalfächer) 1 Klapptür

Apertura con profilo o maniglia
Opening with profile or handle
Ouverture avec profil ou poignée
Apertura con perfil o tirador
Öffnung mit Profil oder Griff

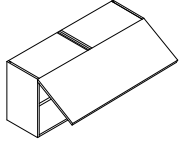

P/D	L/W	CODICE	0	1	2	3	4	5	6	7	8	9	10
34	120	KPW400571201	473	510	572	649	682	739	779	861	937	1.122	1.264

Pensile composto (2 vani ripiani) 1 vasistas

Composite wall unit (2 shelf compartments) 1 vasistas
Elément mural composite (2 compartiments d'étagère) 1 vasistas
Colgante compuesto (1 compartimentos baldas) 1 abatible
Kombi-Hängeschränk (2 Regalfächer) 1 Klapptür

Apertura con profilo o maniglia
Opening with profile or handle
Ouverture avec profil ou poignée
Apertura con perfil o tirador
Öffnung mit Profil oder Griff

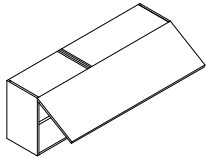

P/D	L/W	CODICE	0	1	2	3	4	5	6	7	8	9	10
34	150	KPW400571501	534	571	692	767	807	877	922	1.021	1.108	1.329	1.429

Non disponibile nelle finiture Fenix NTA, canneté, acciaio inox e metal.

Not available in Fenix NTA, canneté, stainless steel and metal finishes. | Non disponible dans les finitions Fenix NTA, canneté, acier inoxydable et métal. | No disponible en los acabados Fenix NTA, canneté, acero inoxidable y metal. | Nicht erhältlich in den Ausführungen Fenix NTA, Cannelé, Edelstahl und Metall.

Pensile composto (1 vano ripiani + cappa) 1 vasistas

Composite wall unit (1 shelf compartment + hood) 1 vasistas
Elément mural composite (1 compartiment d'étagère + hotte) 1 vasistas
Colgante compuesto (1 compart. baldas + campana) 1 abatible
Kombi-Hängeschränk (1 Regalfach + Abzugshaube) 1 Klapptür

Apertura con profilo o maniglia
Opening with profile or handle
Ouverture avec profil ou poignée
Apertura con perfil o tirador
Öffnung mit Profil oder Griff

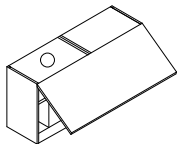

P/D	L/W	CODICE	0	1	2	3	4	5	6	7	8	9	10
34	120	KPY400571201	1.027	1.056	1.088	1.143	1.203	1.233	1.293	1.380	1.742	1.899	1.989

Inclusa di serie cappa inox per piani a gas (per ulteriori tipologie vedere pag. 188)

Included as standard stainless steel hood for gas cooktops (for more types see p. 188) | Hotte standard en acier inoxydable pour plaques de cuisson à gaz incluse (pour d'autres types, voir page 188) | Campana estándar de acero inoxidable para placas de gas incluida (para más tipos, consulte la página 188) | Standard-Edelstahlhaube für Gaskochfelder inklusive (weitere Typen siehe Seite 188)

PENSILI COMPOSTI

Composite wall units
Modules suspendis compósés
Colgantes compuestos
Kombi-Hängeschränke

H. 57

Pensile composto (1 vano ripiani + cappa) 1 vasistas

Composite wall unit (1 shelf compartment + hood) 1 vasistas
Elément mural composite (1 compartiment détagère + hotte) 1 vasistas
Colgante compuesto (1 compart. baldas + campana) 1 abatible
Kombi-Hängeschränk (1 Regalfach + Abzugshaube) 1 Klapptür

Apertura con profilo o maniglia
Opening with profile or handle
Ouverture avec profil ou poignée
Apertura con perfil o tirador
Öffnung mit Profil oder Griff

P/D	L/W	CODICE	0	1	2	3	4	5	6	7	8	9	10
34	150	KPY400571501	1.068	1.101	1.138	1.200	1.268	1.307	1.369	1.465	1.828	1.999	2.089

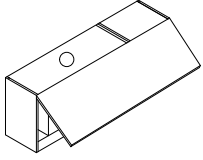

Inclusa di serie cappa inox per piani a gas (per ulteriori tipologie vedere pag. 188)

Included as standard stainless steel hood for gas cooktops (for more types see p. 188) | Hotte standard en acier inoxydable pour plaques de cuisson à gaz incluse (pour d'autres types, voir page 188) | Campana estándar de acero inoxidable para placas de gas incluida (para más tipos, consulte la página 188) | Standard-Edelstahlhaube für Gaskochfelder inklusive (weitere Typen siehe Seite 188)

Non disponibile nelle finiture Fenix NTA, cannelé, acciaio inox e metal.

Not available in Fenix NTA, cannelé, stainless steel and metal finishes. | Non disponible dans les finitions Fenix NTA, cannelé, acier inoxydable et métal. | No disponible en los acabados Fenix NTA, cannelé, acero inoxidable y metal. | Nicht erhältlich in den Ausführungen Fenix NTA, Cannelé, Edelstahl und Metall.

Pensile composto (2 vani ripiani + cappa) 1 vasistas

Composite wall unit (2 shelf compartments + hood) 1 vasistas
Unité murale composite (2 compartiments détagère + hotte) 1 vasistas
Colgante compuesto (2 compart. baldas + campana) 1 abatible
Kombi-Hängeschränk (2 Regalfächer + Abzugshaube) 1 Klapptür

Apertura con profilo o maniglia
Opening with profile or handle
Ouverture avec profil ou poignée
Apertura con perfil o tirador
Öffnung mit Profil oder Griff

P/D	L/W	CODICE	0	1	2	3	4	5	6	7	8	9	10
34	150	KPZ400571501	1.126	1.159	1.196	1.258	1.326	1.365	1.433	1.523	1.888	2.059	2.159

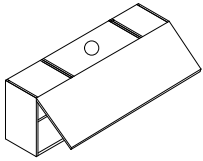

Inclusa di serie cappa inox per piani a gas (per ulteriori tipologie vedere pag. 188)

Included as standard stainless steel hood for gas cooktops (for more types see p. 188) | Hotte standard en acier inoxydable pour plaques de cuisson à gaz incluse (pour d'autres types, voir page 188) | Campana estándar de acero inoxidable para placas de gas incluida (para más tipos, consulte la página 188) | Standard-Edelstahlhaube für Gaskochfelder inklusive (weitere Typen siehe Seite 188)

Non disponibile nelle finiture Fenix NTA, cannelé, acciaio inox e metal.

Not available in Fenix NTA, cannelé, stainless steel and metal finishes. | Non disponible dans les finitions Fenix NTA, cannelé, acier inoxydable et métal. | No disponible en los acabados Fenix NTA, cannelé, acero inoxidable y metal. | Nicht erhältlich in den Ausführungen Fenix NTA, Cannelé, Edelstahl und Metall.

Pensile composto (1 vano ripiani + scolapiatti) 1 vasistas

Composite wall unit (1 shelf compartment + dish drainer) 1 vasistas
Elément mural composite (1 compartiment étagère + égouttoir à vaisselle) 1 vasistas
Colgante compuesto (1 compart. baldas + escurridor) 1 abatible
Kombi-Hängeschränk (1 Regalfach + Abtropffläche) 1 Klapptür

Apertura con profilo o maniglia
Opening with profile or handle
Ouverture avec profil ou poignée
Apertura con perfil o tirador
Öffnung mit Profil oder Griff

P/D	L/W	CODICE	0	1	2	3	4	5	6	7	8	9	10
34	120	KPX400571201	564	602	714	793	834	906	955	1.061	1.153	1.363	1.463

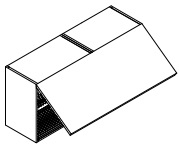

Basi con maniglia
Base units with handle

Basi con gola
Base units with groove

Colonne
Tall units

Pensili
Wall units

Elementi speciali
Special elements

Maniglie gole zoccoli
Handles grooves plinth

Illuminazione
Lighting

Accessori
Accessories

Componenti e meccanismi
Components e mechanism

PENSILI COMPOSTI

Composite wall units
Modules suspendis compôsés
Colgantes compuestos
Kombi-Hängeschränke

H. 57

Pensile composto (1 vano ripiani + scolapiatti) 1 vasistas

Composite wall unit (1 shelf compartment + dish drainer) 1 vasistas

Elément mural composite (1 compartiment étagère + égouttoir à vaisselle) 1 vasistas

Colgante compuesto (1 compart. baldas + escurridor) 1 abatible

Kombi-Hängeschränk (1 Regalfach + Abtropffläche) 1 Klapptür

Apertura con profilo o maniglia

Opening with profile or handle

Ouverture avec profil ou poignée

Apertura con perfil o tirador

Öffnung mit Profil oder Griff

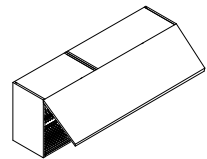

P/D	L/W	CODICE	0	1	2	3	4	5	6	7	8	9	10
34	150	KPX400571501	644	683	809	890	937	1.019	1.073	1.190	1.293	1.530	1.630

Non disponibile nelle finiture Fenix NTA, canneté, acciaio inox e metal.

Not available in Fenix NTA, canneté, stainless steel and metal finishes. | Non disponible dans les finitions Fenix NTA, canneté, acier inoxydable et métal. | No disponible en los acabados Fenix NTA, canneté, acero inoxidable y metal. | Nicht erhältlich in den Ausführungen Fenix NTA, Cannelé, Edelstahl und Metall.

PENSILI VETRINA

Display cabinets
Vitrines
Vitrinas colgantes
Hängeschränke mit Glasstür

H. 57

Pensile vetrina 1 anta

Display cabinet 1 door
Vitrine suspendue 1 porte
Vitrina colgante 1 puerta
Hängeschränk 1 Glasstür

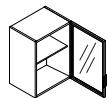

P/D	L/W	CODICE	0	1	2	3	4	5	6	7	8	9	10
34	45	KPV010570451	368	396	497	677	-	-	-	-	-	-	-
34	60	KPV010570601	397	426	535	730	-	-	-	-	-	-	-

Pensile vetrina 2 ante

2 door display cabinet
Vitrine suspendue 2 portes
Vitrina colgantede puertas
Hängeschränk 2 Glasstür

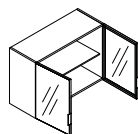

P/D	L/W	CODICE	0	1	2	3	4	5	6	7	8	9	10
34	90	KPV020570901	719	773	971	1.324	-	-	-	-	-	-	-

Basi con maniglia
Base units with handle

Basi con gola
Base units with groove

Colonne
Tall units

Pensili
Wall units

Elementi speciali
Special elements

Maniglie gole zoccoli
Handles grooves plinth

Illuminazione
Lighting

Accessori
Accessories

Componenti e meccanismi
Components e mechanism

PENSILI

Wall cabinets
Modules suspendus
Colgantes
Hängeschränke

H. 72

Riempitivo per pensile con fianco

Wall unit filler with side
Fileur pour modules suspendus avec côté
Relleno para colgante con lateral
Füllung für Hängeschränk mit Ausseneite

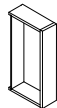

P/D	L/W	CODICE	0	1	2	3	4	5	6	7	8	9	10
34	4-15	KPN900720151	115	126	132	152	160	170	186	207	252	303	343

Pensile 1 anta

Wall unit 1 door
module suspendu 1 porte
Colgante 1 puerta
Hängeschränk 1 Tür

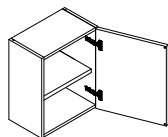

Apertura con profilo o maniglia
Opening with profile or handle
Ouverture avec profil ou poignée
Apertura con perfil o tirador
Öffnung mit Profil oder Griff

P/D	L/W	CODICE	0	1	2	3	4	5	6	7	8	9	10
34	15	KPN010720151	108	124	126	145	159	165	168	213	269	321	371
34	30	KPN010720301	119	143	151	177	198	202	217	273	340	407	457
34	45	KPN010720451	136	161	181	217	239	258	277	341	422	508	558
34	60	KPN010720601	153	168	189	233	261	276	315	391	482	578	628
34	75	KPN010720751	162	170	192	246	281	295	354	439	542	648	698

Pensile 2 ante

2 door wall unit
module suspendu 2 portes
Colgante 2 puertas
2-türiger Hängeschränk

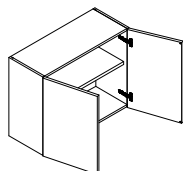

Apertura con profilo o maniglia
Opening with profile or handle
Ouverture avec profil ou poignée
Apertura con perfil o tirador
Öffnung mit Profil oder Griff

P/D	L/W	CODICE	0	1	2	3	4	5	6	7	8	9	10
34	60	KPN020720601	167	198	211	267	289	309	333	442	548	657	707
34	90	KPN020720901	187	226	262	331	359	405	437	562	693	831	881

PENSILI

Wall cabinets
Modules suspendus
Colgantes
Hängeschränke

H. 72

Pensile 2 ante pacchetto verticale

2 door wall unit vertical package
module suspendu 2 portes paquet vertical
Colgante 2 puertas
2-türiger Hängeschränk mit Falttür

Apertura con profilo o maniglia
Opening with profile or handle
Ouverture avec profil ou poignée
Apertura con perfil o tirador
Öffnung mit Profil oder Griff

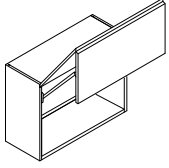

P/D	L/W	CODICE	0	1	2	3	4	5	6	7	8	9	10
34	45	KPN470720451	341	395	407	458	506	530	549	631	770	943	993
34	60	KPN470720601	356	409	432	485	534	559	570	696	860	1.033	1.083
34	75	KPN470720751	371	422	451	512	566	595	624	757	934	1.121	1.171
34	90	KPN470720901	384	434	469	540	598	631	678	816	1.008	1.209	1.259
34	105	KPN470721051	398	463	510	576	614	670	754	892	1.106	1.327	1.377
34	120	KPN470721201	410	491	554	635	700	743	826	971	1.204	1.444	1.494

Pensile 2 vasistas

Wall unit 2 vasistas
module suspendu 2 vasistas
Colgante 2 puertas abatibles
Hängeschränk 2 Klapptür

Apertura con profilo o maniglia
Opening with profile or handle
Ouverture avec profil ou poignée
Apertura con perfil o tirador
Öffnung mit Profil oder Griff

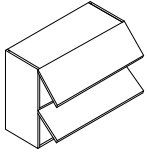

P/D	L/W	CODICE	0	1	2	3	4	5	6	7	8	9	10
34	45	KPN410720451	238	270	287	333	375	400	407	521	643	772	807
34	60	KPN410720601	312	349	372	425	474	498	510	631	782	939	989
34	75	KPN410720751	383	415	439	499	528	564	620	802	993	1.192	1.242
34	90	KPN410720901	456	481	520	589	646	680	724	858	1.062	1.275	1.325
34	105	KPN410721051	472	511	562	639	700	738	803	942	1.165	1.398	1.448
34	120	KPN410721201	489	541	603	690	756	794	883	1.024	1.267	1.520	1.570

Pensile forno microonde 1 vasistas

Microwave oven wall unit 1 vasistas
Four à micro-ondes à poser sur le mur 1 vasistas
Colgante horno microondas 1 p.abatible
Mikrowellenherd Hängeschränk 1 Klapptür

Apertura con profilo o maniglia
Opening with profile or handle
Ouverture avec profil ou poignée
Apertura con perfil o tirador
Öffnung mit Profil oder Griff

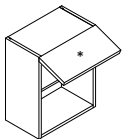

P/D	L/W	CODICE	0	1	2	3	4	5	6	7	8	9	10
34	60	KPM400720601	312	321	344	384	424	434	466	541	673	807	857

* Frontale su misura | Customised front panel | Façade sur mesure | Frente medida especial | Fronten in Sondermasse

Basi con maniglia
Base units with handle

Basi con gola
Base units with groove

Colonne
Tall units

Pensili
Wall units

Elementi speciali
Special elements

Maniglie gole zoccoli
Handles grooves plinth

Illuminazione
Lighting

Accessori
Accessories

Componenti e meccanismi
Components e mechanism

PENSILI

Wall cabinets
Modules suspendus
Colgantes
Hängeschränke

H. 72

Pensile copriboiler 1 anta

Wall unit 1 door for water header / boiler
Couvercle d'armoire murale 1 porte
Colgante 1 puerta para tapar el boiler
Hängeschränkabdeckung 1 Tür

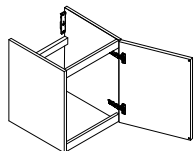

Apertura con profilo o maniglia
Opening with profile or handle
Ouverture avec profil ou poignée
Apertura con perfil o tirador
Öffnung mit Profil oder Griff

P/D	L/W	CODICE	0	1	2	3	4	5	6	7	8	9	10
57	60	KPB010720604	164	196	217	245	253	294	307	377	466	559	599

Pensile angolo 2 ante

Corner wall unit 2 doors
module suspendu d'angle 2 portes
Colgante ángulo 2 puertas
Eck-Hängeschränk 2 Türen

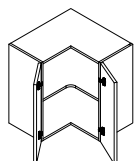

Apertura con profilo o maniglia
Opening with profile or handle
Ouverture avec profil ou poignée
Apertura con perfil o tirador
Öffnung mit Profil oder Griff

P/D	L/W	CODICE	0	1	2	3	4	5	6	7	8	9	10
65	65	KPA020720656	249	262	276	333	367	374	404	507	628	754	780

Pensile angolo 1 anta

Corner wall unit 1 door
module suspendu d'angle 1 porte
Colgante ángulo 1 puerta
Eck-Hängeschränk 1 Tür

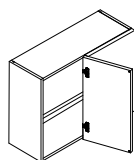

Apertura con profilo o maniglia
Opening with profile or handle
Ouverture avec profil ou poignée
Apertura con perfil o tirador
Öffnung mit Profil oder Griff

P/D	L/W	CODICE	0	1	2	3	4	5	6	7	8	9	10
34	95	KPA010720951D/S	227	265	314	410	442	500	544	683	845	1.013	1.063

PENSILI SCOLAPIATTI

H. 72

Dish drainer wall units
 Modules suspendus avec égouttoir à vaisselle
 Colgantes escurridores
 Hängeschränke mit Abtropfflächen

Pensile scolapiatti 1 anta

Dish drainer wall unit 1 door
 Evier à vaisselle mural 1 porte
 Colgante escurridor 1 puerta
 Geschirrspülbecken Hängeschränk 1 Tür

Apertura con profilo o maniglia
 Opening with profile or handle
 Ouverture avec profil ou poignée
 Apertura con perfil o tirador
 Öffnung mit Profil oder Griff

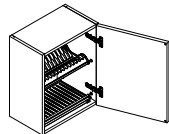

P/D	L/W	CODICE	0	1	2	3	4	5	6	7	8	9	10
34	45	KPS010720451	191	218	238	275	298	318	338	407	493	584	634
34	60	KPS010720601	210	220	242	290	319	337	379	461	557	659	709

Pensile scolapiatti 2 ante

2 door dish rack
 Porte-vaisselle 2 portes
 Colgante escurridor 2 puertas
 2-türiger Geschirrständer

Apertura con profilo o maniglia
 Opening with profile or handle
 Ouverture avec profil ou poignée
 Apertura con perfil o tirador
 Öffnung mit Profil oder Griff

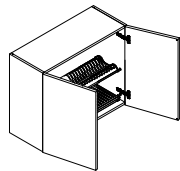

P/D	L/W	CODICE	0	1	2	3	4	5	6	7	8	9	10
34	90	KPS020720901	253	292	328	401	433	485	512	647	788	934	998
34	120	KPS020721201	374	453	509	622	670	755	796	1.005	1.221	1.465	1.525

Pensile scolapiatti 2 ante pacchetto verticale

2 door dish rack vertical package
 Panier à vaisselle 2 portes paquet vertical
 Colgante escurridor 2 puertas paquete vertical
 2-Falztür Geschirregal

Apertura con profilo o maniglia
 Opening with profile or handle
 Ouverture avec profil ou poignée
 Apertura con perfil o tirador
 Öffnung mit Profil oder Griff

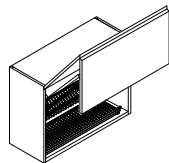

P/D	L/W	CODICE	0	1	2	3	4	5	6	7	8	9	10
34	45	KPS470720451	394	447	472	532	581	607	623	755	929	1.112	1.212
34	60	KPS470720601	423	476	501	561	610	636	652	784	959	1.142	1.242
34	75	KPS470720751	444	496	523	577	608	649	714	852	1.042	1.240	1.340
34	90	KPS470720901	461	510	550	626	686	722	769	917	1.121	1.334	1.434
34	105	KPS470721051	532	599	653	721	760	821	906	1.056	1.285	1.519	1.619
34	120	KPS470721201	600	683	750	836	906	953	1.041	1.192	1.444	1.698	1.798

Basi con maniglia
 Base units with handle

Basi con gola
 Base units with groove

Colonne
 Tall units

Pensili
 Wall units

Elementi speciali
 Special elements

Maniglie gole zoccoli
 Handles grooves plinth

Illuminazione
 Lighting

Accessori
 Accessories

Componenti e meccanismi
 Components e mechanism

PENSILI SCOLAPIATTI

Dish drainer wall units
Modules suspendus avec égouttoir à vaisselle
Colgantes escurridores
Hängeschränke mit Abtropfflächen

H. 72

Pensile scolapiatti 2 vasistas

Dish drainer wall unit 2 vasistas
Egouttoir à vaisselle mural 2 vasistas
Colgante escurridor 2 p.abatibles
2 - Klapptür Geschirrspüler Hängeschränk

Apertura con profilo o maniglia
Opening with profile or handle
Ouverture avec profil ou poignée
Apertura con perfil o tirador
Öffnung mit Profil oder Griff

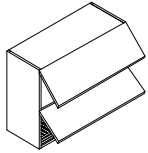

P/D	L/W	CODICE	0	1	2	3	4	5	6	7	8	9	10
34	60	KPS410720601	375	414	437	496	544	570	587	718	876	1.041	1.141
34	75	KPS410720751	461	493	517	579	610	649	707	903	1.106	1.316	1.416
34	90	KPS410720901	509	563	601	674	736	772	818	962	1.180	1.405	1.505
34	105	KPS410721051	566	640	687	757	796	857	973	1.124	1.365	1.612	1.712
34	120	KPS410721201	657	739	807	893	964	1.008	1.098	1.250	1.513	1.780	1.880

PENSILI CAPPA

Wall cabinets hood
 Modules suspendus hotte
 Colgantes con campana
 Hängeschränke Haube

H. 72

Pensile cappa 1 anta

Wall unit hood 1 door
 module suspendu hotte 1 porte
 Colgante campana 1 puerta
 Hängeschrank Haube 1 Tür

Apertura con profilo o maniglia
 Opening with profile or handle
 Ouverture avec profil ou poignée
Apertura con perfil o tirador
 Öffnung mit Profil oder Griff

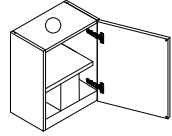

P/D	L/W	CODICE	0	1	2	3	4	5	6	7	8	9	10
34	60	KPC010720601	620	632	644	656	728	758	802	832	953	1.048	1.143
34	75	KPC010720751	655	667	679	691	762	792	837	867	989	1.084	1.179

Inclusa di serie cappa inox per piani a gas (per ulteriori tipologie vedere pag. 188)

Included as standard stainless steel hood for gas cooktops (for more types see p. 188) | Hotte standard en acier inoxydable pour plaques de cuisson à gaz incluse (pour d'autres types, voir page 188) | Campana estándar de acero inoxidable para placas de gas incluida (para más tipos, consulte la página 188) | Standard-Edelstahlhaube für Gaskochfelder inklusive (weitere Typen siehe Seite 188)

Pensile cappa 2 ante

2 door hood wall unit
 module suspendu hotte 2 portes
 Colgante campana 2 puertas
 2-türiger HaubenHängeschrank

Apertura con profilo o maniglia
 Opening with profile or handle
 Ouverture avec profil ou poignée
Apertura con perfil o tirador
 Öffnung mit Profil oder Griff

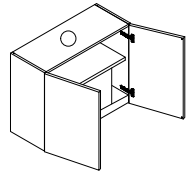

P/D	L/W	CODICE	0	1	2	3	4	5	6	7	8	9	10
34	90	KPC020720901	690	722	754	779	854	902	965	1.012	1.211	1.379	1.547
34	120	KPC020721201	765	807	848	878	966	1.026	1.114	1.176	1.374	1.536	1.698

Inclusa di serie cappa inox per piani a gas (per ulteriori tipologie vedere pag. 188)

Included as standard stainless steel hood for gas cooktops (for more types see p. 188) | Hotte standard en acier inoxydable pour plaques de cuisson à gaz incluse (pour d'autres types, voir page 188) | Campana estándar de acero inoxidable para placas de gas incluida (para más tipos, consulte la página 188) | Standard-Edelstahlhaube für Gaskochfelder inklusive (weitere Typen siehe Seite 188)

Pensile cappa 2 vasistas

Wall-mounted hood 2 vasistas
 module suspendu hotte 2 vasistas
 Colgante campana 2 puertas abatibles
 Wandhaube 2 Klapptür

Apertura con profilo o maniglia
 Opening with profile or handle
 Ouverture avec profil ou poignée
Apertura con perfil o tirador
 Öffnung mit Profil oder Griff

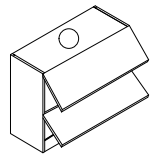

P/D	L/W	CODICE	0	1	2	3	4	5	6	7	8	9	10
34	60	KPC410720601	789	818	846	887	913	951	1.009	1.041	1.335	1.477	1.557
34	75	KPC410720751	811	843	875	923	954	1.000	1.059	1.097	1.404	1.541	1.710
34	90	KPC410720901	832	868	904	960	994	1.049	1.109	1.153	1.451	1.605	1.828
34	120	KPC410721201	932	975	1.018	1.090	1.134	1.203	1.287	1.346	1.656	1.802	2.140

Inclusa di serie cappa inox per piani a gas (per ulteriori tipologie vedere pag. 188)

Included as standard stainless steel hood for gas cooktops (for more types see p. 188) | Hotte standard en acier inoxydable pour plaques de cuisson à gaz incluse (pour d'autres types, voir page 188) | Campana estándar de acero inoxidable para placas de gas incluida (para más tipos, consulte la página 188) | Standard-Edelstahlhaube für Gaskochfelder inklusive (weitere Typen siehe Seite 188)

Basi con maniglia
 Base units with handle

Basi con gola
 Base units with groove

Colonne
 Tall units

Pensili
 Wall units

Elementi speciali
 Special elements

Maniglie gole zoccoli
 Handles grooves plinth

Illuminazione
 Lighting

Accessori
 Accessories

Componenti e meccanismi
 Components e mechanism

PENSILI CAPPA

Wall cabinets hood
Modules suspendus hotte
Colgantes con campana
Hängeschranke Haube

H. 72

Pensile cappa 2 ante pacchetto verticale

2 door hood wall unit vertical package
module suspendu hotte 2 portes e paquet vertical
Colgante campana 2 puertas paquete vertical
2-türiges Hauben-Hängeschrank-mit Falttür

Apertura con profilo o maniglia
Opening with profile or handle
Ouverture avec profil ou poignée
Apertura con perfil o tirador
Öffnung mit Profil oder Griff

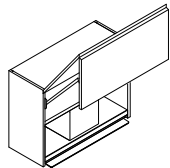

P/D	L/W	CODICE	0	1	2	3	4	5	6	7	8	9	10
34	60	KPC470720601	762	789	815	831	898	954	1.017	1.062	1.302	1.506	1.523
34	75	KPC470720751	803	831	858	876	947	1.005	1.072	1.119	1.371	1.588	1.676
34	90	KPC470720901	844	873	902	921	995	1.056	1.126	1.177	1.417	1.670	1.795
34	120	KPC470721201	926	958	989	1.010	1.092	1.159	1.236	1.291	1.628	1.834	2.111

Inclusa di serie cappa inox per piani a gas (per ulteriori tipologie vedere pag. 188)

Included as standard stainless steel hood for gas cooktops (for more types see p. 188) | Hotte standard en acier inoxydable pour plaques de cuisson à gaz incluse (pour d'autres types, voir page 188) | Campana estándar de acero inoxidable para placas de gas incluida (para más tipos, consulte la página 188) | Standard-Edelstahlhaube für Gaskochfelder inklusive (weitere Typen siehe Seite 188)

PENSILI VETRINA

H. 72

Display cabinets
Vitrines
Vitrinas colgantes
Hängeschränke mit Glasstür

Pensile vetrina 1 anta

Display cabinet 1 door
Vitrine suspendue 1 porte
Vitrina colgante 1 puerta
Hängeschränk 1 Glasstür

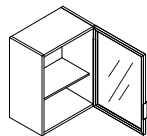

P/D	L/W	CODICE	0	1	2	3	4	5	6	7	8	9	10
34	45	KPV010720451	389	418	524	715	-	-	-	-	-	-	-
34	60	KPV010720601	426	458	575	784	-	-	-	-	-	-	-

Pensile vetrina 2 ante

2 door display cabinet
Vitrine suspendue 2 portes
Vitrina colgantede puertas
Hängeschränk 2 Glasstür

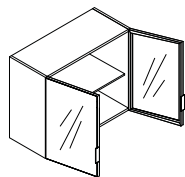

P/D	L/W	CODICE	0	1	2	3	4	5	6	7	8	9	10
34	90	KPV020720901	755	812	1.020	1.390	-	-	-	-	-	-	-

Basi con maniglia
Base units with handle

Basi con gola
Base units with groove

Colonne
Tall units

Pensili
Wall units

Elementi speciali
Special elements

Maniglie gole zoccoli
Handles grooves plinth

Illuminazione
Lighting

Accessori
Accessories

Componenti e meccanismi
Components e mechanism

PENSILI

Wall cabinets
Modules suspendus
Colgantes
Hängeschränke

H. 87

Riempitivo per pensile con fianco

Wall unit filler with side
Fileur pour modules suspendus avec côté
Relleno para colgante con lateral
Füllung für Hängeschränk mit Ausseneite

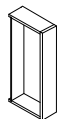

P/D	L/W	CODICE	0	1	2	3	4	5	6	7	8	9	10
34	4-15	KPN900870151	119	134	137	159	170	178	196	213	260	313	353

Pensile 1 anta

Wall unit 1 door
module suspendu 1 porte
Colgante 1 puerta
Hängeschränk 1 Tür

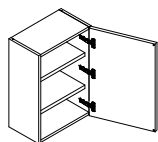

Apertura con profilo o maniglia
Opening with profile or handle
Ouverture avec profil ou poignée
Apertura con perfil o tirador
Öffnung mit Profil oder Griff

P/D	L/W	CODICE	0	1	2	3	4	5	6	7	8	9	10
34	15	KPN010870151	119	145	149	166	178	183	199	230	282	339	389
34	30	KPN010870301	140	166	171	203	233	141	269	328	405	486	536
34	45	KPN010870451	152	176	203	243	269	294	327	397	490	588	638
34	60	KPN010870601	175	189	226	277	312	327	393	480	592	711	761
34	75	KPN010870751	218	256	288	362	395	443	469	569	707	848	898

Pensile 2 ante

2 door wall unit
module suspendu 2 portes
Colgante 2 puertas
2-türiger Hängeschränk

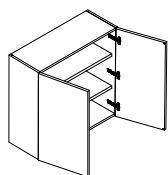

Apertura con profilo o maniglia
Opening with profile or handle
Ouverture avec profil ou poignée
Apertura con perfil o tirador
Öffnung mit Profil oder Griff

P/D	L/W	CODICE	0	1	2	3	4	5	6	7	8	9	10
34	60	KPN020870601	201	242	254	319	348	390	424	515	639	765	851
34	90	KPN020870901	235	265	321	404	440	500	558	679	841	1.008	1.076

PENSILI

Wall cabinets
Modules suspendus
Colgantes
Hängeschränke

H. 87

Pensile copriboiler 1 anta

Wall unit 1 door for water header / boiler
Couvercle d'armoire murale 1 porte
Colgante 1 puerta para tapar el boiler
Hängeschränkabdeckung 1 Tür

Apertura con profilo o maniglia
Opening with profile or handle
Ouverture avec profil ou poignée
Apertura con perfil o tirador
Öffnung mit Profil oder Griff

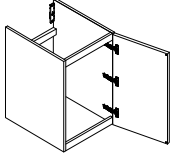

P/D	L/W	CODICE	0	1	2	3	4	5	6	7	8	9	10
57	60	KPB010870604	182	206	241	295	304	341	383	467	578	693	743

Pensile forno microonde 1 anta

Microwave oven cabinet 1 door
Armoire pour four à micro-ondes 1 porte
Colgante horno microondas 1 puerta
Mikrowellenherd Schrank 1 Tür

Apertura con profilo o maniglia
Opening with profile or handle
Ouverture avec profil ou poignée
Apertura con perfil o tirador
Öffnung mit Profil oder Griff

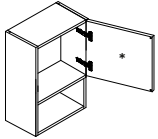

P/D	L/W	CODICE	0	1	2	3	4	5	6	7	8	9	10
34	60	KPM010870601	344	354	379	424	467	477	511	596	740	887	937

* **Frontale su misura** | Customised front panel | Façade sur mesure | Frente medida especial | Fronten in Sondermasse

Pensile angolo 2 ante

Corner wall unit 2 doors
module suspendu d'angle 2 portes
Colgante ángulo 2 puertas
Eck-Hängeschränk 2 Türen

Apertura con profilo o maniglia
Opening with profile or handle
Ouverture avec profil ou poignée
Apertura con perfil o tirador
Öffnung mit Profil oder Griff

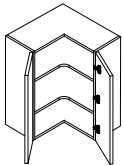

P/D	L/W	CODICE	0	1	2	3	4	5	6	7	8	9	10
65	65	KPA020870656	304	319	340	404	436	474	506	619	764	918	942

Basi con maniglia
Base units with handle

Basi con gola
Base units with groove

Colonne
Tall units

Pensili
Wall units

Elementi speciali
Special elements

Maniglie gole zoccoli
Handles grooves plinth

Illuminazione
Lighting

Accessori
Accessories

Componenti e meccanismi
Components e mechanism

PENSILI

Wall cabinets
Modules suspendus
Colgantes
Hängeschränke

H. 87

Pensile angolo 1 anta

Corner wall unit 1 door
module suspendu d'angle 1 porte
Colgante ángulo 1 puerta
Eck-Hängeschrank 1 Tür

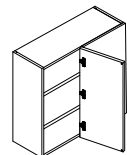

Apertura con profilo o maniglia
Opening with profile or handle
Ouverture avec profil ou poignée
Apertura con perfil o tirador
Öffnung mit Profil oder Griff

P/D	L/W	CODICE	0	1	2	3	4	5	6	7	8	9	10
34	95	KPA010870951D/S	278	319	396	494	542	618	695	841	1.042	1.250	1.300

Pensile 2 ante pacchetto verticale

2 door wall unit vertical package
module suspendu 2 portes paquet vertical
Colgante 2 puertas
2-türiger Hängeschrank mit Falttür

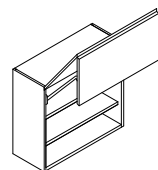

Apertura con profilo o maniglia
Opening with profile or handle
Ouverture avec profil ou poignée
Apertura con perfil o tirador
Öffnung mit Profil oder Griff

P/D	L/W	CODICE	0	1	2	3	4	5	6	7	8	9	10
34	45	KPN470870451	408	472	500	566	626	655	671	825	1.028	1.240	1.290
34	60	KPN470870601	442	506	534	600	660	689	705	859	1.063	1.275	1.325
34	75	KPN470870751	460	519	564	650	722	762	821	989	1.227	1.476	1.526
34	90	KPN470870901	476	535	580	666	738	779	837	1.006	1.244	1.493	1.543
34	105	KPN470871051	491	589	666	768	850	903	1.004	1.182	1.467	1.765	1.815
34	120	KPN470871201	507	605	683	785	866	920	1.020	1.199	1.484	1.782	1.832

Pensile 2 vasistas

Wall unit 2 vasistas
module suspendu 2 vasistas
Colgante 2 puertas abatibles
Hängeschrank 2 Klapptür

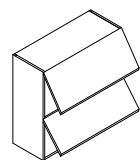

Apertura con profilo o maniglia
Opening with profile or handle
Ouverture avec profil ou poignée
Apertura con perfil o tirador
Öffnung mit Profil oder Griff

P/D	L/W	CODICE	0	1	2	3	4	5	6	7	8	9	10
34	45	KPN410870451	247	296	307	349	404	412	421	532	655	784	834
34	60	KPN410870601	305	355	375	423	478	490	515	627	774	930	980
34	75	KPN410870751	369	414	449	509	572	589	651	839	1.051	1.273	1.323
34	90	KPN410870901	432	477	512	572	635	652	714	902	1.116	1.338	1.388
34	105	KPN410871051	447	493	528	588	651	667	729	918	1.132	1.354	1.404
34	120	KPN410871201	464	495	552	629	704	724	818	947	1.174	1.406	1.456

PENSILI SCOLAPIATTI

H. 87

Dish drainer wall units
 Modules suspendus avec égouttoir à vaisselle
 Colgantes escurridores
 Hängeschränke mit Abtropfflächen

Pensile scolapiatti 1 anta

Dish drainer wall unit 1 door
 Evier à vaisselle mural 1 porte
 Colgante escurridor 1 puerta
 Geschirrspülbecken Hängeschrank 1 Tür

Apertura con profilo o maniglia
 Opening with profile or handle
 Ouverture avec profil ou poignée
 Apertura con perfil o tirador
 Öffnung mit Profil oder Griff

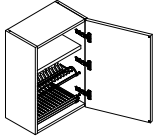

P/D	L/W	CODICE	0	1	2	3	4	5	6	7	8	9	10
34	45	KPS010870451	210	232	259	303	330	354	390	466	567	671	721
34	60	KPS010870601	233	250	288	344	377	395	464	552	677	803	853

Pensile scolapiatti 2 ante

2 door dish rack
 Porte-vaisselle 2 portes
 Colgante escurridor 2 puertas
 2-türiger Geschirrständer

Apertura con profilo o maniglia
 Opening with profile or handle
 Ouverture avec profil ou poignée
 Apertura con perfil o tirador
 Öffnung mit Profil oder Griff

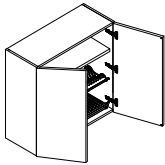

P/D	L/W	CODICE	0	1	2	3	4	5	6	7	8	9	10
34	90	KPS020870901	328	380	393	476	517	579	642	771	944	1.121	1.177
34	120	KPS020871201	444	525	609	738	801	899	993	1.197	1.460	1.753	1.803

Pensile scolapiatti 2 ante pacchetto verticale

2 door dish rack vertical package
 Panier à vaisselle 2 portes paquet vertical
 Colgante escurridor 2 puertas paquete vertical
 2-Falttür Geschirregal

Apertura con profilo o maniglia
 Opening with profile or handle
 Ouverture avec profil ou poignée
 Apertura con perfil o tirador
 Öffnung mit Profil oder Griff

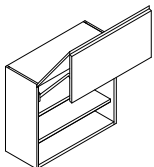

P/D	L/W	CODICE	0	1	2	3	4	5	6	7	8	9	10
34	45	KPS470870451	418	477	504	566	621	648	665	807	997	1.205	1.255
34	60	KPS470870601	457	516	543	605	660	687	704	846	1.037	1.245	1.295
34	75	KPS470870751	476	535	563	625	679	706	724	865	1.057	1.265	1.315
34	90	KPS470870901	499	553	501	675	741	781	832	989	1.212	1.453	1.503
34	105	KPS470871051	573	628	575	750	816	856	907	1.064	1.289	1.530	1.580
34	120	KPS470871201	649	738	811	904	981	1.030	1.126	1.289	1.561	1.872	1.922

Basi con maniglia
 Base units with handle

Basi con gola
 Base units with groove

Colonne
 Tall units

Pensili
 Wall units

Elementi speciali
 Special elements

Maniglie gole zoccoli
 Handles grooves plinth

Illuminazione
 Lighting

Accessori
 Accessories

Componenti e meccanismi
 Components e mechanism

PENSILI SCOLAPIATTI

Dish drainer wall units
Modules suspendus avec égouttoir à vaisselle
Colgantes escurridores
Hängeschränke mit Abtropfflächen

H. 87

Pensile scolapiatti 2 vasistas

Dish drainer wall unit 2 vasistas
Egouttoir à vaisselle mural 2 vasistas
Colgante escurridor 2 p.abatibles
2 - Klapptür Geschirrspüler Hängeschrank

Apertura con profilo o maniglia
Opening with profile or handle
Ouverture avec profil ou poignée
Apertura con perfil o tirador
Öffnung mit Profil oder Griff

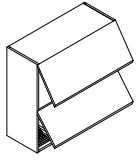

P/D	L/W	CODICE	0	1	2	3	4	5	6	7	8	9	10
34	60	KPS410870601	379	438	466	528	582	609	627	768	957	1.165	1.215
34	75	KPS410870751	399	458	485	547	601	629	646	788	977	1.185	1.235
34	90	KPS410870901	421	475	423	598	663	703	755	912	1.132	1.373	1.423
34	105	KPS410871051	496	550	498	672	738	778	829	986	1.209	1.450	1.500
34	120	KPS410871201	571	661	733	826	903	953	1.049	1.212	1.481	1.792	1.842

PENSILI CAPPA

Wall cabinets hood
Modules suspendus hotte
Colgantes con campana
Hängeschränke Haube

H. 87

Pensile cappa 1 anta

Wall unit hood 1 door
module suspendu hotte 1 porte
Colgante campana 1 puerta
Hängeschrank Haube 1 Tür

Apertura con profilo o maniglia
Opening with profile or handle
Ouverture avec profil ou poignée
Apertura con perfil o tirador
Öffnung mit Profil oder Griff

P/D	L/W	CODICE	0	1	2	3	4	5	6	7	8	9	10
34	60	KPC010870601	683	690	696	721	802	836	888	908	1.042	1.148	1.413
34	75	KPC010870751	720	727	733	758	839	873	924	945	1.080	1.186	1.451

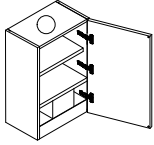

Inclusa di serie cappa inox per piani a gas (per ulteriori tipologie vedere pag. 188)

Included as standard stainless steel hood for gas cooktops (for more types see p. 188) | Hotte standard en acier inoxydable pour plaques de cuisson à gaz incluse (pour d'autres types, voir page 188) | Campana estándar de acero inoxidable para placas de gas incluida (para más tipos, consulte la página 188) | Standard-Edelstahlhaube für Gaskochfelder inklusive (weitere Typen siehe Seite 188)

Pensile cappa 2 ante

2 door hood wall unit
module suspendu hotte 2 portes
Colgante campana 2 puertas
2-türiger HaubenHängeschrank

Apertura con profilo o maniglia
Opening with profile or handle
Ouverture avec profil ou poignée
Apertura con perfil o tirador
Öffnung mit Profil oder Griff

P/D	L/W	CODICE	0	1	2	3	4	5	6	7	8	9	10
34	90	KPC020870901	757	778	799	851	938	992	1.067	1.121	1.402	1.496	1.824
34	120	KPC020871201	822	869	916	939	1.044	1.111	1.214	1.254	1.609	1.651	2.124

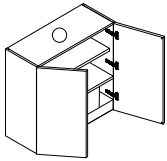

Inclusa di serie cappa inox per piani a gas (per ulteriori tipologie vedere pag. 188)

Included as standard stainless steel hood for gas cooktops (for more types see p. 188) | Hotte standard en acier inoxydable pour plaques de cuisson à gaz incluse (pour d'autres types, voir page 188) | Campana estándar de acero inoxidable para placas de gas incluida (para más tipos, consulte la página 188) | Standard-Edelstahlhaube für Gaskochfelder inklusive (weitere Typen siehe Seite 188)

Pensile cappa 2 vasistas

Wall-mounted hood 2 vasistas
module suspendu hotte 2 vasistas
Colgante campana 2 puertas abatibles
Wandhaube 2 Klapptür

Apertura con profilo o maniglia
Opening with profile or handle
Ouverture avec profil ou poignée
Apertura con perfil o tirador
Öffnung mit Profil oder Griff

P/D	L/W	CODICE	0	1	2	3	4	5	6	7	8	9	10
34	60	KPC410870601	837	867	896	937	970	1.012	1.079	1.115	1.228	1.586	1.616
34	75	KPC410870751	862	896	930	978	1.017	1.067	1.135	1.178	1.312	1.661	1.711
34	90	KPC410870901	888	925	963	1.019	1.063	1.121	1.191	1.241	1.386	1.736	1.811
34	120	KPC410871201	997	1.043	1.088	1.159	1.217	1.291	1.373	1.438	1.607	1.961	2.150

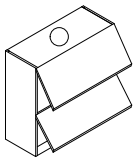

Inclusa di serie cappa inox per piani a gas (per ulteriori tipologie vedere pag. 188)

Included as standard stainless steel hood for gas cooktops (for more types see p. 188) | Hotte standard en acier inoxydable pour plaques de cuisson à gaz incluse (pour d'autres types, voir page 188) | Campana estándar de acero inoxidable para placas de gas incluida (para más tipos, consulte la página 188) | Standard-Edelstahlhaube für Gaskochfelder inklusive (weitere Typen siehe Seite 188)

Basi con maniglia
Base units with handle

Basi con gola
Base units with groove

Colonne
Tall units

Pensili
Wall units

Elementi speciali
Special elements

Maniglie gole zoccoli
Handles grooves plinth

Illuminazione
Lighting

Accessori
Accessories

Componenti e meccanismi
Components e mechanism

PENSILI CAPPA

Wall cabinets hood
Modules suspendus hotte
Colgantes con campana
Hängeschränke Haube

H. 87

Pensile cappa 2 ante pacchetto verticale

2 door hood wall unit vertical package
module suspendu hotte 2 portes e paquet vertical
Colgante campana 2 puertas paquete vertical
2-türiges Hauben-Hängeschränke mit Falttür

Apertura con profilo o maniglia
Opening with profile or handle
Ouverture avec profil ou poignée
Apertura con perfil o tirador
Öffnung mit Profil oder Griff

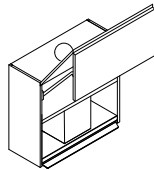

P/D	L/W	CODICE	0	1	2	3	4	5	6	7	8	9	10
34	60	KPC470870601	915	945	974	1.015	1.048	1.089	1.156	1.192	1.308	1.666	1.696
34	75	KPC470870751	940	974	1.008	1.055	1.094	1.145	1.213	1.255	1.392	1.741	1.791
34	90	KPC470870901	965	1.003	1.041	1.096	1.141	1.199	1.269	1.318	1.466	1.816	1.891
34	120	KPC470871201	1.075	1.120	1.166	1.237	1.295	1.369	1.450	1.515	1.687	2.041	2.230

Inclusa di serie cappa inox per piani a gas (per ulteriori tipologie vedere pag. 188)

Included as standard stainless steel hood for gas cooktops (for more types see p. 188) | Hotte standard en acier inoxydable pour plaques de cuisson à gaz incluse (pour d'autres types, voir page 188) | Campana estándar de acero inoxidable para placas de gas incluida (para más tipos, consulte la página 188) | Standard-Edelstahlhaube für Gaskochfelder inklusive (weitere Typen siehe Seite 188)

PENSILI VETRINA

Display cabinets
Vitrines
Vitrinas colgantes
Hängeschränke mit Glasstür

H. 87

Pensile vetrina 1 anta

Display cabinet 1 door
Vitrine suspendue 1 porte
Vitrina colgante 1 puerta
Hängeschränk 1 Glasstür

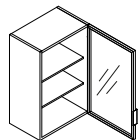

P/D	L/W	CODICE	0	1	2	3	4	5	6	7	8	9	10
34	45	KPV010870451	447	481	604	823	-	-	-	-	-	-	-
34	60	KPV010870601	492	529	665	906	-	-	-	-	-	-	-

Pensile vetrina 2 ante

2 door display cabinet
Vitrine suspendue 2 portes
Vitrina colgantede puertas
Hängeschränk 2 Glasstür

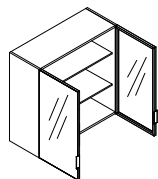

P/D	L/W	CODICE	0	1	2	3	4	5	6	7	8	9	10
34	90	KPV020870901	879	945	1.187	1.618	-	-	-	-	-	-	-

Basi con maniglia
Base units with handle

Basi con gola
Base units with groove

Colonne
Tall units

Pensili
Wall units

Elementi speciali
Special elements

Maniglie gole zoccoli
Handles grooves plinth

Illuminazione
Lighting

Accessori
Accessories

Componenti e meccanismi
Components e mechanism

PENSILI

Wall cabinets
Modules suspendus
Colgantes
Hängeschränke

H. 102

Riempitivo per pensile con fianco

Wall unit filler with side
Fileur pour modules suspendus avec côté
Relleno para colgante con lateral
Füllung für Hängeschränk mit Ausseneite

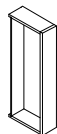

P/D	L/W	CODICE	0	1	2	3	4	5	6	7	8	9	10
34	4-15	KPN901020151	140	155	176	204	215	226	238	274	332	399	449

Pensile 1 anta

Wall unit 1 door
module suspendu 1 porte
Colgante 1 puerta
Hängeschränk 1 Tür

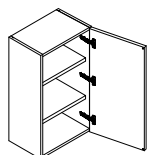

Apertura con profilo o maniglia
Opening with profile or handle
Ouverture avec profil ou poignée
Apertura con perfil o tirador
Öffnung mit Profil oder Griff

P/D	L/W	CODICE	0	1	2	3	4	5	6	7	8	9	10
34	15	KPN011020151	152	178	200	234	255	288	321	364	461	560	610
34	30	KPN011020301	194	220	242	275	297	330	363	405	504	603	653
34	45	KPN011020451	212	243	286	327	350	400	432	501	619	743	793
34	60	KPN011020601	235	256	309	372	400	442	506	590	728	875	925
34	75	KPN011020751	316	328	353	419	434	517	564	699	862	1.032	1.082

Pensile 2 ante

2 door wall unit
module suspendu 2 portes
Colgante 2 puertas
2-türiger Hängeschränk

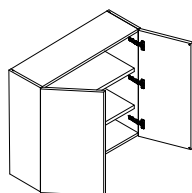

Apertura con profilo o maniglia
Opening with profile or handle
Ouverture avec profil ou poignée
Apertura con perfil o tirador
Öffnung mit Profil oder Griff

P/D	L/W	CODICE	0	1	2	3	4	5	6	7	8	9	10
34	60	KPN021020601	307	318	343	409	424	507	554	690	852	1.022	1.072
34	90	KPN021020901	326	345	433	512	562	661	722	885	1.092	1.311	1.351

PENSILI

Wall cabinets
Modules suspendus
Colgantes
Hängeschränke

H. 102

Pensile copriboiler 1 anta

Wall unit 1 door for water header / boiler
Couvercle d'armoire murale 1 porte
Colgante 1 puerta para tapar el boiler
Hängeschränkabdeckung 1 Tür

Apertura con profilo o maniglia
Opening with profile or handle
Ouverture avec profil ou poignée
Apertura con perfil o tirador
Öffnung mit Profil oder Griff

P/D	L/W	CODICE	0	1	2	3	4	5	6	7	8	9	10
57	60	KPB011020604	210	238	276	340	349	395	442	536	665	839	889

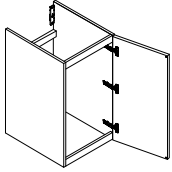

Pensile forno microonde 1 anta

Microwave oven cabinet 1 door
Armoire pour four à micro-ondes 1 porte
Colgante horno microondas 1 puerta
Mikrowellenherd Schrank 1 Tür

Apertura con profilo o maniglia
Opening with profile or handle
Ouverture avec profil ou poignée
Apertura con perfil o tirador
Öffnung mit Profil oder Griff

P/D	L/W	CODICE	0	1	2	3	4	5	6	7	8	9	10
34	60	KPM011020601	393	403	428	472	515	526	560	644	790	937	987

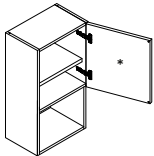

* **Frontale su misura** | Customised front panel | Façade sur mesure | Frente medida especial | Fronten in Sondermasse

Pensile angolo 2 ante

Corner wall unit 2 doors
module suspendu d'angle 2 portes
Colgante ángulo 2 puertas
Eck-Hängeschränk 2 Türen

Apertura con profilo o maniglia
Opening with profile or handle
Ouverture avec profil ou poignée
Apertura con perfil o tirador
Öffnung mit Profil oder Griff

P/D	L/W	CODICE	0	1	2	3	4	5	6	7	8	9	10
65	65	KPA021020656	389	404	426	489	521	592	614	760	939	1.126	1.176

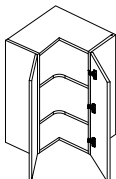

Basi con maniglia
Base units with handle

Basi con gola
Base units with groove

Colonne
Tall units

Pensili
Wall units

Elementi speciali
Special elements

Maniglie gole zoccoli
Handles grooves plinth

Illuminazione
Lighting

Accessori
Accessories

Componenti e meccanismi
Components e mechanism

PENSILI

Wall cabinets
Modules suspendus
Colgantes
Hängeschränke

H. 102

Pensile angolo 1 anta

Corner wall unit 1 door
module suspendu d'angle 1 porte
Colgante ángulo 1 puerta
Eck-Hängeschränk 1 Tür

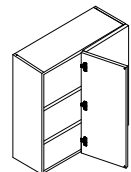

Apertura con profilo o maniglia
Opening with profile or handle
Ouverture avec profil ou poignée
Apertura con perfil o tirador
Öffnung mit Profil oder Griff

P/D	L/W	CODICE	0	1	2	3	4	5	6	7	8	9	10
34	95	KPA011020951D/S	364	384	481	571	627	734	802	983	1.216	1.459	1.509

Pensile 2 ante pacchetto verticale

2 door wall unit vertical package
module suspendu 2 portes paquet vertical
Colgante 2 puertas
2-türiger Hängeschränk mit Falttür

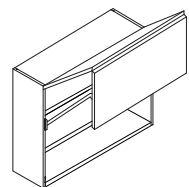

Apertura con profilo o maniglia
Opening with profile or handle
Ouverture avec profil ou poignée
Apertura con perfil o tirador
Öffnung mit Profil oder Griff

P/D	L/W	CODICE	0	1	2	3	4	5	6	7	8	9	10
34	45	KPN471020451	486	550	577	644	703	732	749	903	1.108	1.320	1.370
34	60	KPN471020601	520	584	611	678	737	766	783	937	1.143	1.355	1.405
34	75	KPN471020751	537	597	641	728	799	840	898	1.067	1.307	1.556	1.606
34	90	KPN471020901	554	613	658	744	816	857	915	1.083	1.324	1.573	1.623
34	105	KPN471021051	568	666	744	846	927	981	1.082	1.260	1.547	1.845	1.895
34	120	KPN471021201	585	683	760	862	944	997	1.098	1.277	1.564	1.862	1.912

Pensile 2 vasistas

Wall unit 2 vasistas
module suspendu 2 vasistas
Colgante 2 puertas abatibles
Hängeschränk 2 Klapptür

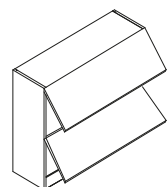

Apertura con profilo o maniglia
Opening with profile or handle
Ouverture avec profil ou poignée
Apertura con perfil o tirador
Öffnung mit Profil oder Griff

P/D	L/W	CODICE	0	1	2	3	4	5	6	7	8	9	10
34	45	KPN411020451	447	511	538	605	664	694	710	864	1.068	1.280	1.330
34	60	KPN411020601	481	545	572	639	698	728	744	898	1.103	1.315	1.365
34	75	KPN411020751	499	558	602	689	760	801	859	1.028	1.267	1.516	1.566
34	90	KPN411020901	515	574	619	705	777	818	876	1.045	1.284	1.533	1.583
34	105	KPN411021051	530	628	705	807	889	942	1.043	1.221	1.507	1.805	1.855
34	120	KPN411021201	546	644	722	824	905	958	1.059	1.238	1.524	1.822	1.872

PENSILI SCOLAPIATTI

H. 102

Dish drainer wall units
 Modules suspendus avec égouttoir à vaisselle
 Colgantes escurridores
 Hängeschränke mit Abtropfflächen

Pensile scolapiatti 1 anta

Dish drainer wall unit 1 door
 Evier à vaisselle mural 1 porte
 Colgante escurridor 1 puerta
 Geschirrspülbecken Hängeschränk 1 Tür

Apertura con profilo o maniglia
 Opening with profile or handle
 Ouverture avec profil ou poignée
 Apertura con perfil o tirador
 Öffnung mit Profil oder Griff

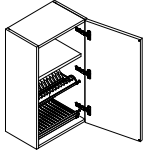

P/D	L/W	CODICE	0	1	2	3	4	5	6	7	8	9	10
34	45	KPS011020451	273	303	348	390	417	468	501	576	703	833	883
34	60	KPS011020601	316	337	393	459	489	534	601	690	840	993	1.043

Pensile scolapiatti 2 ante

2 door dish rack
 Porte-vaisselle 2 portes
 Colgante escurridor 2 puertas
 2-türiger Geschirrständer

Apertura con profilo o maniglia
 Opening with profile or handle
 Ouverture avec profil ou poignée
 Apertura con perfil o tirador
 Öffnung mit Profil oder Griff

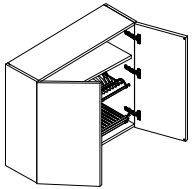

P/D	L/W	CODICE	0	1	2	3	4	5	6	7	8	9	10
34	90	KPS021020901	417	437	529	617	666	771	835	1.008	1.232	1.462	1.512

Pensile scolapiatti 2 ante pacchetto verticale

2 door dish rack vertical package
 Panier à vaisselle 2 portes paquet vertical
 Colgante escurridor 2 puertas paquete vertical
 2-Falttür Geschirregal

Apertura con profilo o maniglia
 Opening with profile or handle
 Ouverture avec profil ou poignée
 Apertura con perfil o tirador
 Öffnung mit Profil oder Griff

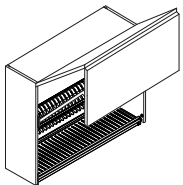

P/D	L/W	CODICE	0	1	2	3	4	5	6	7	8	9	10
34	45	KPS471020451	496	555	582	644	698	726	743	885	1.077	1.285	1.335
34	60	KPS471020601	534	594	621	683	737	764	782	923	1.117	1.325	1.375
34	75	KPS471020751	554	613	640	702	757	784	801	943	1.137	1.345	1.395
34	90	KPS471020901	576	631	578	753	819	858	910	1.067	1.292	1.533	1.583
34	105	KPS471021051	651	705	653	827	893	933	985	1.142	1.369	1.610	1.660
34	120	KPS471021201	727	816	889	982	1.058	1.108	1.204	1.367	1.641	1.952	2.002

Basi con maniglia
 Base units with handle

Basi con gola
 Base units with groove

Colonne
 Tall units

Pensili
 Wall units

Elementi speciali
 Special elements

Maniglie gole zoccoli
 Handles grooves plinth

Illuminazione
 Lighting

Accessori
 Accessories

Componenti e meccanismi
 Components e mechanism

PENSILI SCOLAPIATTI

Dish drainer wall units
 Modules suspendus avec égouttoir à vaisselle
 Colgantes escurridores
 Hängeschränke mit Abtropfflächen

H. 102

Pensile scolapiatti 2 vasistas

Dish drainer wall unit 2 vasistas
 Egouttoir à vaisselle mural 2 vasistas
 Colgante escurridor 2 p.abatibles
 2 - Klapptür Geschirrspüler Hängeschrank

Apertura con profilo o maniglia
 Opening with profile or handle
 Ouverture avec profil ou poignée
 Apertura con perfil o tirador
 Öffnung mit Profil oder Griff

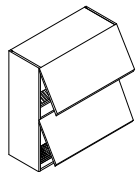

P/D	L/W	CODICE	0	1	2	3	4	5	6	7	8	9	10
34	60	KPS411020601	418	477	504	566	621	648	665	807	997	1.205	1.255
34	75	KPS411020751	457	516	543	605	660	687	704	846	1.037	1.245	1.295
34	90	KPS411020901	476	535	563	625	679	706	724	865	1.057	1.265	1.315
34	105	KPS411021051	499	553	501	675	741	781	832	989	1.212	1.453	1.503
34	120	KPS411021201	573	628	575	750	816	856	907	1.064	1.289	1.530	1.580

PENSILI CAPPA

Wall cabinets hood
Modules suspendus hotte
Colgantes con campana
Hängeschränke Haube

H. 102

Pensile cappa 1 anta

Wall unit hood 1 door
module suspendu hotte 1 porte
Colgante campana 1 puerta
Hängeschrank Haube 1 Tür

Apertura con profilo o maniglia
Opening with profile or handle
Ouverture avec profil ou poignée
Apertura con perfil o tirador
Öffnung mit Profil oder Griff

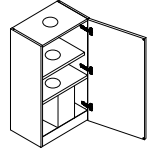

P/D	L/W	CODICE	0	1	2	3	4	5	6	7	8	9	10
34	60	KPC011020601	789	801	813	839	955	1.003	1.059	1.110	1.214	1.350	1.507
34	75	KPC011020751	829	860	890	943	1.082	1.159	1.239	1.315	1.530	1.703	1.753

Inclusa di serie cappa inox per piani a gas (per ulteriori tipologie vedere pag. 188)

Included as standard stainless steel hood for gas cooktops (for more types see p. 188) | Hotte standard en acier inoxydable pour plaques de cuisson à gaz incluse (pour d'autres types, voir page 188) | Campana estándar de acero inoxidable para placas de gas incluida (para más tipos, consulte la página 188) | Standard-Edelstahlhaube für Gaskochfelder inklusive (weitere Typen siehe Seite 188)

Pensile cappa 2 ante

2 door hood wall unit
module suspendu hotte 2 portes
Colgante campana 2 puertas
2-türiger HaubenHängeschrank

Apertura con profilo o maniglia
Opening with profile or handle
Ouverture avec profil ou poignée
Apertura con perfil o tirador
Öffnung mit Profil oder Griff

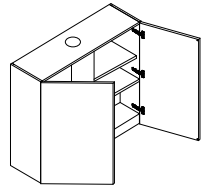

P/D	L/W	CODICE	0	1	2	3	4	5	6	7	8	9	10
34	90	KPC021020901	858	889	920	972	1.111	1.188	1.268	1.344	1.490	1.733	1.972
34	120	KPC021021201	936	967	997	1.050	1.188	1.266	1.345	1.422	1.570	1.813	2.052

Inclusa di serie cappa inox per piani a gas (per ulteriori tipologie vedere pag. 188)

Included as standard stainless steel hood for gas cooktops (for more types see p. 188) | Hotte standard en acier inoxydable pour plaques de cuisson à gaz incluse (pour d'autres types, voir page 188) | Campana estándar de acero inoxidable para placas de gas incluida (para más tipos, consulte la página 188) | Standard-Edelstahlhaube für Gaskochfelder inklusive (weitere Typen siehe Seite 188)

Pensile cappa 2 vasistas

Wall-mounted hood 2 vasistas
module suspendu hotte 2 vasistas
Colgante campana 2 puertas abatibles
Wandhaube 2 Klapptür

Apertura con profilo o maniglia
Opening with profile or handle
Ouverture avec profil ou poignée
Apertura con perfil o tirador
Öffnung mit Profil oder Griff

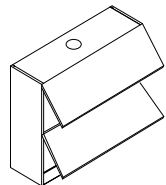

P/D	L/W	CODICE	0	1	2	3	4	5	6	7	8	9	10
34	60	KPC411020601	915	945	974	1.015	1.048	1.089	1.156	1.192	1.308	1.666	1.696
34	75	KPC411020751	940	974	1.008	1.055	1.094	1.145	1.213	1.255	1.392	1.741	1.791
34	90	KPC411020901	965	1.003	1.041	1.096	1.141	1.199	1.289	1.318	1.466	1.816	1.891
34	120	KPC411021201	1.075	1.120	1.166	1.237	1.295	1.369	1.450	1.515	1.687	2.041	2.230

Inclusa di serie cappa inox per piani a gas (per ulteriori tipologie vedere pag. 188)

Included as standard stainless steel hood for gas cooktops (for more types see p. 188) | Hotte standard en acier inoxydable pour plaques de cuisson à gaz incluse (pour d'autres types, voir page 188) | Campana estándar de acero inoxidable para placas de gas incluida (para más tipos, consulte la página 188) | Standard-Edelstahlhaube für Gaskochfelder inklusive (weitere Typen siehe Seite 188)

Basi con maniglia
Base units with handle

Basi con gola
Base units with groove

Colonne
Tall units

Pensili
Wall units

Elementi speciali
Special elements

Maniglie gole zoccoli
Handles grooves plinth

Illuminazione
Lighting

Accessori
Accessories

Componenti e meccanismi
Components e mechanism

PENSILI CAPPA

Wall cabinets hood
Modules suspendus hotte
Colgantes con campana
Hängeschränke Haube

H. 102

Pensile cappa 2 ante pacchetto verticale

2 door hood wall unit vertical package
module suspendu hotte 2 portes e paquet vertical
Colgante campana 2 puertas paquete vertical
2-türiges Hauben-Hängeschrank-mit Falttür

Apertura con profilo o maniglia
Opening with profile or handle
Ouverture avec profil ou poignée
Apertura con perfil o tirador
Öffnung mit Profil oder Griff

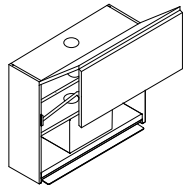

P/D	L/W	CODICE	0	1	2	3	4	5	6	7	8	9	10
34	60	KPC471020601	992	1.022	1.051	1.092	1.125	1.167	1.234	1.270	1.388	1.746	1.776
34	75	KPC471020751	1.018	1.051	1.085	1.133	1.172	1.222	1.290	1.333	1.472	1.821	1.871
34	90	KPC471020901	1.043	1.081	1.118	1.174	1.218	1.277	1.346	1.396	1.546	1.896	1.971
34	120	KPC471021201	1.152	1.198	1.244	1.314	1.373	1.446	1.528	1.593	1.767	2.121	2.310

Inclusa di serie cappa inox per piani a gas (per ulteriori tipologie vedere pag. 188)

Included as standard stainless steel hood for gas cooktops (for more types see p. 188) | Hotte standard en acier inoxydable pour plaques de cuisson à gaz incluse (pour d'autres types, voir page 188) | Campana estándar de acero inoxidable para placas de gas incluida (para más tipos, consulte la página 188) | Standard-Edelstahlhaube für Gaskochfelder inklusive (weitere Typen siehe Seite 188)

PENSILI VETRINA

Display cabinets
Vitrines
Vitrinas colgantes
Hängeschränke mit Glasstür

H. 102

Pensile vetrina 1 anta

Display cabinet 1 door
Vitrine suspendue 1 porte
Vitrina colgante 1 puerta
Hängeschränk 1 Glasstür

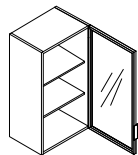

P/D	L/W	CODICE	0	1	2	3	4	5	6	7	8	9	10
34	45	KPV011020451	473	508	638	870	-	-	-	-	-	-	-
34	60	KPV011020601	522	561	705	961	-	-	-	-	-	-	-

Pensile vetrina 2 ante

2 door display cabinet
Vitrine suspendue 2 portes
Vitrina colgantede puertas
Hängeschränk 2 Glasstür

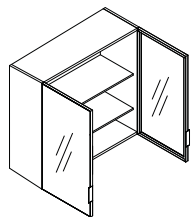

P/D	L/W	CODICE	0	1	2	3	4	5	6	7	8	9	10
34	90	KPV021020901	925	995	1.249	1.703	-	-	-	-	-	-	-

Basi con maniglia
Base units with handle

Basi con gola
Base units with groove

Colonne
Tall units

Pensili
Wall units

Elementi speciali
Special elements

Maniglie gole zoccoli
Handles grooves plinth

Illuminazione
Lighting

Accessori
Accessories

Componenti e meccanismi
Components e mechanism

ELEMENTI SPECIALI

Special Elements
Éléments spéciaux
Elementos especiales
Besondere Elemente

ELEMENTI A GIORNO Open units Éléments ouverts Elementos abiertos Éléments ouverts	P. 238
COLONNE RIENTRANTI Pocket doors tall units Colonne portes rentrantes Columnas retráctiles Versenkte Hochschränke	P. 252
COLONNE FOLDING Folding tall units Colonne folding Columnas folding Klappbare Hochschränke	P. 256
CASSETTI ESTERNI External drawers Tiroir extérieur laqué mat Cajones exteriores Externe Schubladen	P. 259

Componenti e meccanismi Components e mechanism	Accessori Accessories	Illuminazione Lighting	Maniglie gole zoccoli Handles grooves plinth	Elementi speciali Special elements	Pensili Wall units	Colonne Tall units	Basi con gola Base units with groove	Basi con maniglia Base units with handle
--	---------------------------------	----------------------------------	--	--	------------------------------	------------------------------	--	--

FINITURE ELEMENTI A GIORNO

Open element finishes
Finitions des éléments ouverts
Acabados de elementos abiertos
Offene Elementausführungen

Elementi contenitori a parete con struttura sp. 22 mm, schiena sp. 18 mm e divisori sp. 22 mm. Completi di attaccaglie a scomparsa regolabili, vengono consegnati montati.

Per questi elementi è previsto il fuori misura.

Wall-mounted storage elements with 22 mm thick frame, 18 mm thick back and 22 mm thick dividers. Complete with adjustable concealed attachments, they are delivered assembled.

Oversize is provided for these elements.

Éléments de rangement muraux avec cadre de 22 mm d'épaisseur, dos de 18 mm d'épaisseur et séparateurs de 22 mm d'épaisseur. Ils sont livrés assemblés et équipés d'attaches dissimulées réglables.

Sur mesure disponible pour ces éléments.

Elementos de almacenaje con estructura esp. 22 mm, trasera 18 mm y divisorios 22 mm de grosor. Completos con fijaciones ocultas ajustables, se entregan montados.

Para estos elementos son posibles medidas especiales.

Wandablageelemente mit 22 mm starkem Rahmen, 18 mm starkem Rücken und 22 mm starken Trennwänden. Sie werden komplett montiert mit verstellbaren, verdeckten Befestigungen.

Für diese Elemente sind Übergrößen erhältlich.

FINITURE FINISHES FINITIONS ACABADOS AUSFÜHRUNG	SETTIMANE WEEKS SEMAINES SEMANAS WOCHEN	FASCIA DI PREZZO PRICE RANGE CATÉGORIE DE PRIX CATEGORÍA DE PRECIO PREISKLASSE
<ul style="list-style-type: none"> MATERICO TEXTURED FINISH MU0 Bianco, MU1 Sabbia, MU2 Alpaca, MU3 Quarzo MS0 Centauri, MS1 Eris, MS2 Bronzo, MS3 Metallo MR0 Perla, MR1 Argilla, MR2 Lava ML0 Noce California, ML1 Noce Alabama, ML2 Rovere Virginia, ML3 Rovere Termotrattato 	4	0
<ul style="list-style-type: none"> LACCATO OPACO MATT LACQUER O10 Bianco, O00 Panna, O01 Crema, O02 Grigio Perla, O03 Grigio Seta, O04 Corda, O05 Moka, O06 Blu Cobalto, O07 Grigio Aston, O08 Grigio Antracite, O09 Nero 	5	3
<ul style="list-style-type: none"> FENIX NTM® FENIX NTM® FM0 Bianco Kos, FM1 Beige Arizona, FM2 Castoro Ottawa, FM3 Grigio Londra, FM4 Rosso Jaipur, FM5 Verde Comodoro, FM6 Nero Ingo 	5	4
<ul style="list-style-type: none"> LACCATO LUCIDO GLOSSY LACQUERED L10Bianco, L00 Panna, L01 Crema, L02 Grigio Perla, L03 Grigio Seta, L04 Corda, L05 Moka, L06 Blu Cobalto, L07 Grigio Aston, L08 Grigio Antracite, L09 Nero 	6	5
<ul style="list-style-type: none"> LACCATO METALLO LACQUERED METAL L00 Ottone, L01 Acciaio, L02 Bronzo LS0 Oro, LS1 Ottone, LS2 Bronzo scuro, LS3 Titanio LA0 Ottone, LA1 Bronzo scuro, LA2 Silicio 	8	9
<ul style="list-style-type: none"> ESSENZA 1 WOOD 1 ER0 Rovere Visone, ER1 Rovere Castoro, ER2 Rovere Carbone, ER3 Rovere Cenere 	8	7
<ul style="list-style-type: none"> ESSENZA 2 WOOD 2 EE0 Noce Canaletto, EE1 Rovere Termotrattato 	8	9

BASI A GIORNO

Open base units
Bases ouvertes
Bases abiertas
Offene Unterschränke

H. 39

Base a giorno H. 39

Base abierta H. 39
Base ouverte H. 39
Base abierta H. 39
Offener Unterschrank H. 39

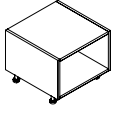

P/D	L/W	CODICE	0	1	2	3	4	5	6	7	8	9	10
36,8	45	KMG010390451	93	-	-	285	306	330	-	716	-	848	-
36,8	60	KMG010390601	107	-	-	327	339	367	-	837	-	996	-
36,8	75	KMG010390751	126	-	-	375	400	432	-	964	-	1.150	-
36,8	90	KMG010390901	139	-	-	417	446	482	-	1.086	-	1.298	-
36,8	105	KMG010391051	152	-	-	460	499	539	-	1.207	-	1.446	-
36,8	120	KMG010391201	165	-	-	502	552	596	-	1.328	-	1.594	-
59,8	45	KMG010390454	100	-	-	377	400	432	-	981	-	1.171	-
59,8	60	KMG010390604	120	-	-	431	466	503	-	1.139	-	1.364	-
59,8	75	KMG010390754	145	-	-	493	547	591	-	1.302	-	1.562	-
59,8	90	KMG010390904	165	-	-	547	604	653	-	1.459	-	1.755	-
59,8	105	KMG010391054	180	-	-	602	676	730	-	1.617	-	1.948	-
59,8	120	KMG010391204	200	-	-	657	748	808	-	1.775	-	2.140	-
64,8	45	KMG010390455	104	-	-	390	402	434	-	1.016	-	1.236	-
64,8	60	KMG010390605	124	-	-	447	472	509	-	1.181	-	1.438	-
64,8	75	KMG010390755	149	-	-	511	557	602	-	1.353	-	1.646	-
64,8	90	KMG010390905	169	-	-	569	618	668	-	1.518	-	1.848	-
64,8	105	KMG010391055	188	-	-	627	695	750	-	1.684	-	2.051	-
64,8	120	KMG010391205	208	-	-	684	761	822	-	1.849	-	2.253	-
69,8	45	KMG010390457	111	-	-	410	428	462	-	1.074	-	1.306	-
69,8	60	KMG010390607	131	-	-	470	503	543	-	1.247	-	1.518	-
69,8	75	KMG010390757	158	-	-	537	594	641	-	1.426	-	1.736	-
69,8	90	KMG010390907	179	-	-	597	658	710	-	1.599	-	1.948	-
69,8	105	KMG010391057	199	-	-	658	729	787	-	1.773	-	2.160	-
69,8	120	KMG010391207	220	-	-	718	809	874	-	1.946	-	2.372	-
74,8	45	KMG010390458	117	-	-	430	450	486	-	1.131	-	1.376	-
74,8	60	KMG010390608	139	-	-	493	533	576	-	1.312	-	1.598	-
74,8	75	KMG010390758	167	-	-	562	612	661	-	1.499	-	1.825	-
74,8	90	KMG010390908	188	-	-	626	697	753	-	1.681	-	2.047	-
74,8	105	KMG010391058	210	-	-	689	771	833	-	1.862	-	2.269	-
74,8	120	KMG010391208	232	-	-	752	856	924	-	2.043	-	2.490	-

Basi con maniglia
Base units with handle

Basi con gola
Base units with groove

Colonne
Tall units

Pensili
Wall units

Elementi speciali
Special elements

Maniglie gole zoccoli
Handles grooves plinth

Illuminazione
Lighting

Accessori
Accessories

Componenti e meccanismi
Components e mechanism

BASI A GIORNO

Open base units
Bases ouvertes
Bases abiertas
Offene Unterschränke

H. 40,5

Base a giorno H. 40,5

Base abierta H. 40,5
Base ouverte H. 40,5
Base abierta H. 40,5
Offener Unterschrank H. 40,5

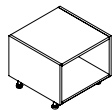

P/D	L/W	CODICE	0	1	2	3	4	5	6	7	8	9	10
36,8	45	KMG010400451	93	-	-	285	306	330	-	716	-	848	-
36,8	60	KMG010400601	107	-	-	327	339	367	-	837	-	996	-
36,8	75	KMG010400751	126	-	-	375	400	432	-	964	-	1.150	-
36,8	90	KMG010400901	139	-	-	417	446	482	-	1.086	-	1.298	-
36,8	105	KMG010401051	152	-	-	460	499	539	-	1.207	-	1.446	-
36,8	120	KMG010401201	165	-	-	502	552	596	-	1.328	-	1.594	-
59,8	45	KMG010400454	100	-	-	377	400	432	-	981	-	1.171	-
59,8	60	KMG010400604	120	-	-	431	466	503	-	1.139	-	1.364	-
59,8	75	KMG010400754	145	-	-	493	547	591	-	1.302	-	1.562	-
59,8	90	KMG010400904	165	-	-	547	604	653	-	1.459	-	1.755	-
59,8	105	KMG010401054	180	-	-	602	676	730	-	1.617	-	1.948	-
59,8	120	KMG010401204	200	-	-	657	748	808	-	1.775	-	2.140	-
64,8	45	KMG010400455	104	-	-	390	402	434	-	1.016	-	1.236	-
64,8	60	KMG010400605	124	-	-	447	472	509	-	1.181	-	1.438	-
64,8	75	KMG010400755	149	-	-	511	557	602	-	1.353	-	1.646	-
64,8	90	KMG010400905	169	-	-	569	618	668	-	1.518	-	1.848	-
64,8	105	KMG010401055	188	-	-	627	695	750	-	1.684	-	2.051	-
64,8	120	KMG010401205	208	-	-	684	761	822	-	1.849	-	2.253	-
69,8	45	KMG010400457	111	-	-	410	428	462	-	1.074	-	1.306	-
69,8	60	KMG010400607	131	-	-	470	503	543	-	1.247	-	1.518	-
69,8	75	KMG010400757	158	-	-	537	594	641	-	1.426	-	1.736	-
69,8	90	KMG010400907	179	-	-	597	658	710	-	1.599	-	1.948	-
69,8	105	KMG010401057	199	-	-	658	729	787	-	1.773	-	2.160	-
69,8	120	KMG010401207	220	-	-	718	809	874	-	1.946	-	2.372	-
74,8	45	KMG010400458	117	-	-	430	450	486	-	1.131	-	1.376	-
74,8	60	KMG010400608	139	-	-	493	533	576	-	1.312	-	1.598	-
74,8	75	KMG010400758	167	-	-	562	612	661	-	1.499	-	1.825	-
74,8	90	KMG010400908	188	-	-	626	697	753	-	1.681	-	2.047	-
74,8	105	KMG010401058	210	-	-	689	771	833	-	1.862	-	2.269	-
74,8	120	KMG010401208	232	-	-	752	856	924	-	2.043	-	2.490	-

BASI A GIORNO

Open base units
Bases ouvertes
Bases abiertas
Offene Unterschränke

H. 45,5

Base a giorno H. 45,5

Base abierta H. 45,5
Base ouverte H. 45,5
Base abierta H. 45,5
Offener Unterschrank H. 45.5

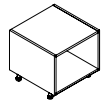

P/D	L/W	CODICE	0	1	2	3	4	5	6	7	8	9	10
36,8	45	KMG010450451	99	-	-	304	310	335	-	771	-	915	-
36,8	60	KMG010450601	113	-	-	348	354	383	-	897	-	1.069	-
36,8	75	KMG010450751	133	-	-	398	415	449	-	1.029	-	1.229	-
36,8	90	KMG010450901	147	-	-	442	467	505	-	1.156	-	1.383	-
36,8	105	KMG010451051	161	-	-	486	523	565	-	1.282	-	1.538	-
36,8	120	KMG010451201	175	-	-	530	579	625	-	1.409	-	1.692	-
59,8	45	KMG010450454	110	-	-	401	428	462	-	1.051	-	1.257	-
59,8	60	KMG010450604	130	-	-	458	504	544	-	1.214	-	1.456	-
59,8	75	KMG010450754	155	-	-	521	586	633	-	1.382	-	1.661	-
59,8	90	KMG010450904	175	-	-	577	648	700	-	1.545	-	1.860	-
59,8	105	KMG010451054	195	-	-	634	723	781	-	1.708	-	2.059	-
59,8	120	KMG010451204	215	-	-	690	798	862	-	1.871	-	2.258	-
64,8	45	KMG010450455	113	-	-	416	431	466	-	1.090	-	1.326	-
64,8	60	KMG010450605	133	-	-	475	512	552	-	1.260	-	1.535	-
64,8	75	KMG010450755	160	-	-	541	598	646	-	1.437	-	1.749	-
64,8	90	KMG010450905	180	-	-	600	664	717	-	1.607	-	1.957	-
64,8	105	KMG010451055	200	-	-	659	744	803	-	1.778	-	2.166	-
64,8	120	KMG010451205	221	-	-	719	813	878	-	1.948	-	2.375	-
69,8	45	KMG010450457	120	-	-	437	455	492	-	1.151	-	1.401	-
69,8	60	KMG010450607	141	-	-	499	540	583	-	1.329	-	1.619	-
69,8	75	KMG010450757	169	-	-	567	632	683	-	1.513	-	1.843	-
69,8	90	KMG010450907	190	-	-	630	701	757	-	1.692	-	2.061	-
69,8	105	KMG010451057	212	-	-	692	776	838	-	1.870	-	2.279	-
69,8	120	KMG010451207	233	-	-	754	858	927	-	2.049	-	2.498	-
74,8	45	KMG010450458	127	-	-	458	480	518	-	1.212	-	1.475	-
74,8	60	KMG010450608	149	-	-	523	573	619	-	1.398	-	1.703	-
74,8	75	KMG010450758	178	-	-	594	653	705	-	1.590	-	1.937	-
74,8	90	KMG010450908	200	-	-	659	743	802	-	1.777	-	2.164	-
74,8	105	KMG010451058	223	-	-	724	821	886	-	1.963	-	2.392	-
74,8	120	KMG010451208	246	-	-	789	908	981	-	2.149	-	2.620	-

Basi con maniglia
Base units with handle

Basi con gola
Base units with groove

Colonne
Tall units

Pensili
Wall units

Elementi speciali
Special elements

Maniglie gole zoccoli
Handles grooves plinth

Illuminazione
Lighting

Accessori
Accessories

Componenti e meccanismi
Components e mechanism

BASI A GIORNO

Open base units
Bases ouvertes
Bases abiertas
Offene Unterschränke

H. 48,5

Base a giorno H. 48,5

Base abierta H. 48,5
Base ouverte H. 48,5
Base abierta H. 48,5
Offener Unterschrank H. 48,5

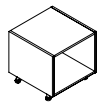

P/D	L/W	CODICE	0	1	2	3	4	5	6	7	8	9	10
36,8	45	KMG010480451	99	-	-	304	310	335	-	771	-	915	-
36,8	60	KMG010480601	113	-	-	348	354	383	-	897	-	1.069	-
36,8	75	KMG010480751	133	-	-	398	415	449	-	1.029	-	1.229	-
36,8	90	KMG010480901	147	-	-	442	467	505	-	1.156	-	1.383	-
36,8	105	KMG010481051	161	-	-	486	523	565	-	1.282	-	1.538	-
36,8	120	KMG010481201	175	-	-	530	579	625	-	1.409	-	1.692	-
59,8	45	KMG010480454	110	-	-	401	428	462	-	1.051	-	1.257	-
59,8	60	KMG010480604	130	-	-	458	504	544	-	1.214	-	1.456	-
59,8	75	KMG010480754	155	-	-	521	586	633	-	1.382	-	1.661	-
59,8	90	KMG010480904	175	-	-	577	648	700	-	1.545	-	1.860	-
59,8	105	KMG010481054	195	-	-	634	723	781	-	1.708	-	2.059	-
59,8	120	KMG010481204	215	-	-	690	798	862	-	1.871	-	2.258	-
64,8	45	KMG010480455	113	-	-	416	431	466	-	1.090	-	1.326	-
64,8	60	KMG010480605	133	-	-	475	512	552	-	1.260	-	1.535	-
64,8	75	KMG010480755	160	-	-	541	598	646	-	1.437	-	1.749	-
64,8	90	KMG010480905	180	-	-	600	664	717	-	1.607	-	1.957	-
64,8	105	KMG010481055	200	-	-	659	744	803	-	1.778	-	2.166	-
64,8	120	KMG010481205	221	-	-	719	813	878	-	1.948	-	2.375	-
69,8	45	KMG010480457	120	-	-	437	455	492	-	1.151	-	1.401	-
69,8	60	KMG010480607	141	-	-	499	540	583	-	1.329	-	1.619	-
69,8	75	KMG010480757	169	-	-	567	632	683	-	1.513	-	1.843	-
69,8	90	KMG010480907	190	-	-	630	701	757	-	1.692	-	2.061	-
69,8	105	KMG010481057	212	-	-	692	776	838	-	1.870	-	2.279	-
69,8	120	KMG010481207	233	-	-	754	858	927	-	2.049	-	2.498	-
74,8	45	KMG010480458	127	-	-	458	480	518	-	1.212	-	1.475	-
74,8	60	KMG010480608	149	-	-	523	573	619	-	1.398	-	1.703	-
74,8	75	KMG010480758	178	-	-	594	653	705	-	1.590	-	1.937	-
74,8	90	KMG010480908	200	-	-	659	743	802	-	1.777	-	2.164	-
74,8	105	KMG010481058	223	-	-	724	821	886	-	1.963	-	2.392	-
74,8	120	KMG010481208	246	-	-	789	908	981	-	2.149	-	2.620	-

BASI A GIORNO

Open base units
Bases ouvertes
Bases abiertas
Offene Unterschränke

H. 58,5

Base a giorno H. 58,5

Base abierta H. 58,5
Base ouverte H. 58,5
Base abierta H. 58,5
Offener Unterschrank H. 58.5

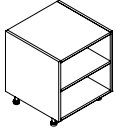

P/D	L/W	CODICE	0	1	2	3	4	5	6	7	8	9	10
36,8	45	KMG010580451	123	-	-	393	411	444	-	1.010	-	1.207	-
36,8	60	KMG010580601	143	-	-	454	470	508	-	1.186	-	1.421	-
36,8	75	KMG010580751	168	-	-	521	555	600	-	1.366	-	1.640	-
36,8	90	KMG010580901	188	-	-	582	630	681	-	1.541	-	1.854	-
36,8	105	KMG010581051	207	-	-	643	698	754	-	1.717	-	2.068	-
36,8	120	KMG010581201	227	-	-	704	776	838	-	1.892	-	2.282	-
59,8	45	KMG010580454	145	-	-	525	568	614	-	1.390	-	1.670	-
59,8	60	KMG010580604	175	-	-	605	674	728	-	1.619	-	1.951	-
59,8	75	KMG010580754	210	-	-	691	791	854	-	1.854	-	2.237	-
59,8	90	KMG010580904	235	-	-	771	887	958	-	2.084	-	2.517	-
59,8	105	KMG010581054	265	-	-	851	978	1.057	-	2.313	-	2.798	-
59,8	120	KMG010581204	295	-	-	931	1.085	1.171	-	2.543	-	3.079	-
64,8	45	KMG010580455	149	-	-	542	575	621	-	1.435	-	1.747	-
64,8	60	KMG010580605	178	-	-	625	686	740	-	1.672	-	2.037	-
64,8	75	KMG010580755	213	-	-	714	807	872	-	1.915	-	2.333	-
64,8	90	KMG010580905	241	-	-	796	907	980	-	2.153	-	2.623	-
64,8	105	KMG010581055	270	-	-	879	1.003	1.083	-	2.390	-	2.914	-
64,8	120	KMG010581205	298	-	-	961	1.103	1.191	-	2.628	-	3.204	-
69,8	45	KMG010580457	157	-	-	565	608	656	-	1.503	-	1.830	-
69,8	60	KMG010580607	187	-	-	651	723	780	-	1.748	-	2.130	-
69,8	75	KMG010580757	223	-	-	743	850	918	-	1.999	-	2.435	-
69,8	90	KMG010580907	252	-	-	828	953	1.029	-	2.244	-	2.735	-
69,8	105	KMG010581057	282	-	-	913	1.043	1.127	-	2.490	-	3.035	-
69,8	120	KMG010581207	312	-	-	999	1.157	1.250	-	2.735	-	3.335	-
74,8	45	KMG010580458	165	-	-	589	636	687	-	1.571	-	1.913	-
74,8	60	KMG010580608	196	-	-	677	760	820	-	1.824	-	2.223	-
74,8	75	KMG010580758	233	-	-	772	875	945	-	2.083	-	2.538	-
74,8	90	KMG010580908	264	-	-	860	998	1.078	-	2.336	-	2.847	-
74,8	105	KMG010581058	294	-	-	948	1.092	1.179	-	2.589	-	3.157	-
74,8	120	KMG010581208	325	-	-	1.036	1.211	1.308	-	2.842	-	3.466	-

Basi con maniglia
Base units with handle

Basi con gola
Base units with groove

Colonne
Tall units

Pensili
Wall units

Elementi speciali
Special elements

Maniglie gole zoccoli
Handles grooves plinth

Illuminazione
Lighting

Accessori
Accessories

Componenti e meccanismi
Components e mechanism

BASI A GIORNO

H. 61,5

Open base units
Bases ouvertes
Bases abiertas
Offene Unterschränke

Base a giorno H. 61,5

Base abierta H. 61,5
Base ouverte H. 61,5
Base abierta H. 61,5
Offener Unterschrank H. 61.5

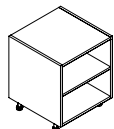

P/D	L/W	CODICE	0	1	2	3	4	5	6	7	8	9	10
36,8	45	KMG010610451	123	-	-	393	411	444	-	1.010	-	1.207	-
36,8	60	KMG010610601	143	-	-	454	470	508	-	1.186	-	1.421	-
36,8	75	KMG010610751	168	-	-	521	555	600	-	1.366	-	1.640	-
36,8	90	KMG010610901	188	-	-	582	630	681	-	1.541	-	1.854	-
36,8	105	KMG010611051	207	-	-	643	698	754	-	1.717	-	2.068	-
36,8	120	KMG010611201	227	-	-	704	776	838	-	1.892	-	2.282	-
59,8	45	KMG010610454	145	-	-	525	568	614	-	1.390	-	1.670	-
59,8	60	KMG010610604	175	-	-	605	674	728	-	1.619	-	1.951	-
59,8	75	KMG010610754	210	-	-	691	791	854	-	1.854	-	2.237	-
59,8	90	KMG010610904	235	-	-	771	887	958	-	2.084	-	2.517	-
59,8	105	KMG010611054	265	-	-	851	978	1.057	-	2.313	-	2.798	-
59,8	120	KMG010611204	295	-	-	931	1.085	1.171	-	2.543	-	3.079	-
64,8	45	KMG010610455	149	-	-	542	575	621	-	1.435	-	1.747	-
64,8	60	KMG010610605	178	-	-	625	686	740	-	1.672	-	2.037	-
64,8	75	KMG010610755	213	-	-	714	807	872	-	1.915	-	2.333	-
64,8	90	KMG010610905	241	-	-	796	907	980	-	2.153	-	2.623	-
64,8	105	KMG010611055	270	-	-	879	1.003	1.083	-	2.390	-	2.914	-
64,8	120	KMG010611205	298	-	-	961	1.103	1.191	-	2.628	-	3.204	-
69,8	45	KMG010610457	157	-	-	565	608	656	-	1.503	-	1.830	-
69,8	60	KMG010610607	187	-	-	651	723	780	-	1.748	-	2.130	-
69,8	75	KMG010610757	223	-	-	743	850	918	-	1.999	-	2.435	-
69,8	90	KMG010610907	252	-	-	828	953	1.029	-	2.244	-	2.735	-
69,8	105	KMG010611057	282	-	-	913	1.043	1.127	-	2.490	-	3.035	-
69,8	120	KMG010611207	312	-	-	999	1.157	1.250	-	2.735	-	3.335	-
74,8	45	KMG010610458	165	-	-	589	636	687	-	1.571	-	1.913	-
74,8	60	KMG010610608	196	-	-	677	760	820	-	1.824	-	2.223	-
74,8	75	KMG010610758	233	-	-	772	875	945	-	2.083	-	2.538	-
74,8	90	KMG010610908	264	-	-	860	998	1.078	-	2.336	-	2.847	-
74,8	105	KMG010611058	294	-	-	948	1.092	1.179	-	2.589	-	3.157	-
74,8	120	KMG010611208	325	-	-	1.036	1.211	1.308	-	2.842	-	3.466	-

BASI A GIORNO

Open base units
Bases ouvertes
Bases abiertas
Offene Unterschränke

H. 78

Base a giorno H. 78

Base abierta H. 78
Base ouverte H. 78
Base abierta H. 78
Offener Unterschrank H. 78

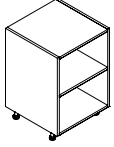

P/D	L/W	CODICE	0	1	2	3	4	5	6	7	8	9	10
36,8	45	KMG010780451	141	-	-	450	483	522	-	1.175	-	1.407	-
36,8	60	KMG010780601	163	-	-	516	553	597	-	1.365	-	1.640	-
36,8	75	KMG010780751	191	-	-	589	640	691	-	1.561	-	1.878	-
36,8	90	KMG010780901	212	-	-	655	722	780	-	1.752	-	2.111	-
36,8	105	KMG010781051	234	-	-	721	801	865	-	1.942	-	2.343	-
36,8	120	KMG010781201	256	-	-	787	886	957	-	2.133	-	2.576	-
59,8	45	KMG010780454	170	-	-	598	668	721	-	1.601	-	1.928	-
59,8	60	KMG010780604	200	-	-	684	784	847	-	1.846	-	2.228	-
59,8	75	KMG010780754	240	-	-	775	903	975	-	2.096	-	2.533	-
59,8	90	KMG010780904	270	-	-	860	1.007	1.087	-	2.341	-	2.832	-
59,8	105	KMG010781054	300	-	-	946	1.109	1.197	-	2.586	-	3.132	-
59,8	120	KMG010781204	330	-	-	1.031	1.223	1.321	-	2.831	-	3.431	-
64,8	45	KMG010780455	176	-	-	619	666	719	-	1.656	-	2.018	-
64,8	60	KMG010780605	207	-	-	707	787	850	-	1.909	-	2.327	-
64,8	75	KMG010780755	243	-	-	801	910	983	-	2.168	-	2.642	-
64,8	90	KMG010780905	274	-	-	889	1.017	1.099	-	2.420	-	2.951	-
64,8	105	KMG010781055	305	-	-	977	1.124	1.214	-	2.673	-	3.260	-
64,8	120	KMG010781205	336	-	-	1.065	1.233	1.331	-	2.926	-	3.569	-
69,8	45	KMG010780457	185	-	-	646	703	759	-	1.735	-	2.113	-
69,8	60	KMG010780607	217	-	-	737	829	895	-	1.995	-	2.432	-
69,8	75	KMG010780757	255	-	-	834	957	1.034	-	2.261	-	2.756	-
69,8	90	KMG010780907	287	-	-	925	1.068	1.153	-	2.522	-	3.075	-
69,8	105	KMG010781057	319	-	-	1.015	1.169	1.262	-	2.783	-	3.394	-
69,8	120	KMG010781207	351	-	-	1.106	1.291	1.395	-	3.043	-	3.713	-
74,8	45	KMG010780458	194	-	-	673	737	795	-	1.813	-	2.209	-
74,8	60	KMG010780608	227	-	-	767	871	940	-	2.081	-	2.537	-
74,8	75	KMG010780758	267	-	-	867	987	1.066	-	2.355	-	2.871	-
74,8	90	KMG010780908	300	-	-	960	1.118	1.208	-	2.624	-	3.200	-
74,8	105	KMG010781058	333	-	-	1.054	1.223	1.321	-	2.892	-	3.528	-
74,8	120	KMG010781208	366	-	-	1.147	1.350	1.458	-	3.161	-	3.857	-

Basi con maniglia
Base units with handle

Basi con gola
Base units with groove

Colonne
Tall units

Pensili
Wall units

Elementi speciali
Special elements

Maniglie gole zoccoli
Handles grooves plinth

Illuminazione
Lighting

Accessori
Accessories

Componenti e meccanismi
Components e mechanism

BASI A GIORNO

Open base units
Bases ouvertes
Bases abiertas
Offene Unterschränke

H. 81

Base a giorno H. 81

Base abierta H. 81
Base ouverte H. 81
Base abierta H. 81
Offener Unterschrank H. 81

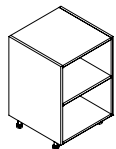

P/D	L/W	CODICE	0	1	2	3	4	5	6	7	8	9	10
36,8	45	KMG010810451	141	-	-	450	483	522	-	1.175	-	1.407	-
36,8	60	KMG010810601	163	-	-	516	553	597	-	1.365	-	1.640	-
36,8	75	KMG010810751	191	-	-	589	640	691	-	1.561	-	1.878	-
36,8	90	KMG010810901	212	-	-	655	722	780	-	1.752	-	2.111	-
36,8	105	KMG010811051	234	-	-	721	801	865	-	1.942	-	2.343	-
36,8	120	KMG010811201	256	-	-	787	886	957	-	2.133	-	2.576	-
59,8	45	KMG010810454	170	-	-	598	668	721	-	1.601	-	1.928	-
59,8	60	KMG010810604	200	-	-	684	784	847	-	1.846	-	2.228	-
59,8	75	KMG010810754	240	-	-	775	903	975	-	2.096	-	2.533	-
59,8	90	KMG010810904	270	-	-	860	1.007	1.087	-	2.341	-	2.832	-
59,8	105	KMG010811054	300	-	-	946	1.109	1.197	-	2.586	-	3.132	-
59,8	120	KMG010811204	330	-	-	1.031	1.223	1.321	-	2.831	-	3.431	-
64,8	45	KMG010810455	176	-	-	619	666	719	-	1.656	-	2.018	-
64,8	60	KMG010810605	207	-	-	707	787	850	-	1.909	-	2.327	-
64,8	75	KMG010810755	243	-	-	801	910	983	-	2.168	-	2.642	-
64,8	90	KMG010810905	274	-	-	889	1.017	1.099	-	2.420	-	2.951	-
64,8	105	KMG010811055	305	-	-	977	1.124	1.214	-	2.673	-	3.260	-
64,8	120	KMG010811205	336	-	-	1.065	1.233	1.331	-	2.926	-	3.569	-
69,8	45	KMG010810457	185	-	-	646	703	759	-	1.735	-	2.113	-
69,8	60	KMG010810607	217	-	-	737	829	895	-	1.995	-	2.432	-
69,8	75	KMG010810757	255	-	-	834	957	1.034	-	2.261	-	2.756	-
69,8	90	KMG010810907	287	-	-	925	1.068	1.153	-	2.522	-	3.075	-
69,8	105	KMG010811057	319	-	-	1.015	1.169	1.262	-	2.783	-	3.394	-
69,8	120	KMG010811207	351	-	-	1.106	1.291	1.395	-	3.043	-	3.713	-
74,8	45	KMG010810458	194	-	-	673	737	795	-	1.813	-	2.209	-
74,8	60	KMG010810608	227	-	-	767	871	940	-	2.081	-	2.537	-
74,8	75	KMG010810758	267	-	-	867	987	1.066	-	2.355	-	2.871	-
74,8	90	KMG010810908	300	-	-	960	1.118	1.208	-	2.624	-	3.200	-
74,8	105	KMG010811058	333	-	-	1.054	1.223	1.321	-	2.892	-	3.528	-
74,8	120	KMG010811208	366	-	-	1.147	1.350	1.458	-	3.161	-	3.857	-

COLONNE A GIORNO

Open tall units
Colonnes ouvertes
Columnas abiertas
Offene Hochschranke

Colonna a giorno H. 99

Columna abierta H. 99
Colonne ouverte H. 99
Columna abierta H. 99
Offene Hochschrank H. 99

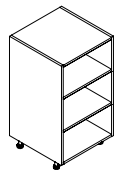

P/D	L/W	CODICE	0	1	2	3	4	5	6	7	8	9	10
36,8	45	KMG020990451	172	-	-	563	608	657	-	1.482	-	1.781	-
36,8	60	KMG020990601	200	-	-	649	690	745	-	1.727	-	2.081	-
36,8	75	KMG020990751	235	-	-	740	810	875	-	1.978	-	2.387	-
36,8	90	KMG020990901	263	-	-	825	913	986	-	2.224	-	2.686	-
59,8	45	KMG020990454	220	-	-	752	834	901	-	2.026	-	2.447	-
59,8	60	KMG020990604	260	-	-	863	978	1.056	-	2.344	-	2.836	-
59,8	75	KMG020990754	305	-	-	980	1.140	1.231	-	2.668	-	3.230	-
59,8	90	KMG020990904	345	-	-	1.091	1.275	1.377	-	2.985	-	3.619	-
64,8	45	KMG020990455	223	-	-	777	853	921	-	2.093	-	2.550	-
64,8	60	KMG020990605	263	-	-	890	1.002	1.082	-	2.418	-	2.949	-
64,8	75	KMG020990755	309	-	-	1.010	1.169	1.262	-	2.750	-	3.353	-
64,8	90	KMG020990905	349	-	-	1.124	1.307	1.411	-	3.076	-	3.751	-
69,8	45	KMG020990457	234	-	-	808	897	968	-	2.182	-	2.659	-
69,8	60	KMG020990607	275	-	-	924	1.050	1.134	-	2.515	-	3.067	-
69,8	75	KMG020990757	322	-	-	1.047	1.222	1.320	-	2.855	-	3.481	-
69,8	90	KMG020990907	363	-	-	1.163	1.364	1.473	-	3.188	-	3.889	-
74,8	45	KMG020990458	245	-	-	839	926	1.000	-	2.271	-	2.768	-
74,8	60	KMG020990608	287	-	-	958	1.088	1.175	-	2.612	-	3.186	-
74,8	75	KMG020990758	335	-	-	1.083	1.248	1.348	-	2.960	-	3.609	-
74,8	90	KMG020990908	378	-	-	1.202	1.410	1.523	-	3.301	-	4.027	-

Colonna a giorno H. 132

Columna abierta H. 132
Colonne ouverte e H. 132
Columna abierta H. 132
Offene Hochschrank H. 132

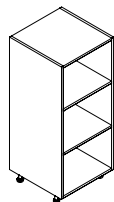

P/D	L/W	CODICE	0	1	2	3	4	5	6	7	8	9	10
36,8	45	KMG021320451	202	-	-	660	723	780	-	1.759	-	2.120	-
36,8	60	KMG021320601	235	-	-	754	821	886	-	2.031	-	2.452	-
36,8	75	KMG021320751	273	-	-	855	954	1.031	-	2.308	-	2.789	-
36,8	90	KMG021320901	305	-	-	949	1.077	1.163	-	2.579	-	3.121	-
59,8	45	KMG021320454	260	-	-	877	979	1.058	-	2.383	-	2.884	-
59,8	60	KMG021320604	305	-	-	996	1.139	1.231	-	2.727	-	3.304	-
59,8	75	KMG021320754	355	-	-	1.123	1.315	1.421	-	3.077	-	3.731	-
59,8	90	KMG021320904	400	-	-	1.242	1.470	1.588	-	3.421	-	4.152	-
64,8	45	KMG021320455	267	-	-	907	1.008	1.089	-	2.467	-	3.008	-
64,8	60	KMG021320605	311	-	-	1.030	1.173	1.266	-	2.819	-	3.439	-
64,8	75	KMG021320755	361	-	-	1.159	1.353	1.461	-	3.177	-	3.875	-
64,8	90	KMG021320905	405	-	-	1.281	1.511	1.632	-	3.528	-	4.305	-
69,8	45	KMG021320457	281	-	-	944	1.061	1.146	-	2.574	-	3.138	-
69,8	60	KMG021320607	326	-	-	1.069	1.230	1.328	-	2.933	-	3.578	-
69,8	75	KMG021320757	377	-	-	1.201	1.416	1.529	-	3.299	-	4.024	-
69,8	90	KMG021320907	422	-	-	1.326	1.577	1.703	-	3.658	-	4.464	-
74,8	45	KMG021320458	294	-	-	981	1.110	1.198	-	2.680	-	3.269	-
74,8	60	KMG021320608	340	-	-	1.109	1.287	1.390	-	3.048	-	3.718	-
74,8	75	KMG021320758	392	-	-	1.244	1.461	1.578	-	3.421	-	4.174	-
74,8	90	KMG021320908	438	-	-	1.372	1.643	1.775	-	3.788	-	4.624	-

Basi con maniglia
Base units with handle

Basi con gola
Base units with groove

Colonne
Tall units

Pensili
Wall units

Elementi speciali
Special elements

Maniglie gole zoccoli
Handles grooves plinth

Illuminazione
Lighting

Accessori
Accessories

Componenti e meccanismi
Components e mechanism

COLONNE A GIORNO

Open tall units
Colonne ouvertes
Columnas abiertas
Offene Hochschränke

Colonna a giorno H. 195

Columna abierta H. 195
Colonne ouverte H. 195
Columna abierta H. 195
Offene Hochschrank h. 195

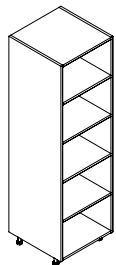

P/D	L/W	CODICE	0	1	2	3	4	5	6	7	8	9	10
36,8	45	KMG021950451	284	-	-	947	1.015	1.097	-	2.550	-	3.085	-
36,8	60	KMG021950601	331	-	-	1.085	1.167	1.260	-	2.948	-	3.571	-
36,8	75	KMG021950751	385	-	-	1.230	1.362	1.471	-	3.352	-	4.063	-
36,8	90	KMG021950901	433	-	-	1.368	1.546	1.670	-	3.749	-	4.549	-
59,8	45	KMG021950454	385	-	-	1.264	1.432	1.546	-	3.461	-	4.199	-
59,8	60	KMG021950604	450	-	-	1.440	1.675	1.809	-	3.968	-	4.819	-
59,8	75	KMG021950754	520	-	-	1.623	1.934	2.089	-	4.480	-	5.444	-
59,8	90	KMG021950904	585	-	-	1.800	2.172	2.346	-	4.986	-	6.064	-
64,8	45	KMG021950455	390	-	-	1.306	1.479	1.597	-	3.578	-	4.364	-
64,8	60	KMG021950605	455	-	-	1.485	1.728	1.866	-	4.092	-	4.993	-
64,8	75	KMG021950755	525	-	-	1.671	1.991	2.150	-	4.613	-	5.628	-
64,8	90	KMG021950905	590	-	-	1.850	2.232	2.411	-	5.127	-	6.258	-
69,8	45	KMG021950457	408	-	-	1.355	1.550	1.675	-	3.718	-	4.535	-
69,8	60	KMG021950607	474	-	-	1.537	1.804	1.948	-	4.240	-	5.174	-
69,8	75	KMG021950757	546	-	-	1.725	2.072	2.238	-	4.768	-	5.819	-
69,8	90	KMG021950907	611	-	-	1.907	2.317	2.502	-	5.290	-	6.458	-
74,8	45	KMG021950458	426	-	-	1.403	1.618	1.747	-	3.857	-	4.706	-
74,8	60	KMG021950608	493	-	-	1.588	1.879	2.030	-	4.387	-	5.355	-
74,8	75	KMG021950758	566	-	-	1.779	2.136	2.307	-	4.923	-	6.009	-
74,8	90	KMG021950908	633	-	-	1.964	2.401	2.593	-	5.453	-	6.658	-

Colonna a giorno H. 210

Columna abierta H. 210
Colonne ouverte H. 210
Columna abierta H. 210
Offene Hochschrank h. 210

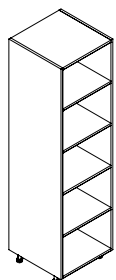

P/D	L/W	CODICE	0	1	2	3	4	5	6	7	8	9	10
36,8	45	KMG022100451	298	-	-	991	1.067	1.153	-	2.677	-	3.239	-
36,8	60	KMG022100601	347	-	-	1.133	1.225	1.323	-	3.086	-	3.740	-
36,8	75	KMG022100751	402	-	-	1.282	1.428	1.542	-	3.501	-	4.246	-
36,8	90	KMG022100901	452	-	-	1.425	1.618	1.748	-	3.911	-	4.747	-
59,8	45	KMG022100454	408	-	-	1.320	1.504	1.625	-	3.623	-	4.397	-
59,8	60	KMG022100604	478	-	-	1.501	1.755	1.895	-	4.142	-	5.032	-
59,8	75	KMG022100754	545	-	-	1.688	2.021	2.182	-	4.666	-	5.672	-
59,8	90	KMG022100904	610	-	-	1.869	2.265	2.446	-	5.184	-	6.306	-
64,8	45	KMG022100455	410	-	-	1.365	1.556	1.681	-	3.748	-	4.572	-
64,8	60	KMG022100605	476	-	-	1.548	1.811	1.956	-	4.275	-	5.216	-
64,8	75	KMG022100755	549	-	-	1.738	2.081	2.248	-	4.807	-	5.866	-
64,8	90	KMG022100905	615	-	-	1.922	2.329	2.516	-	5.333	-	6.510	-
69,8	45	KMG022100457	429	-	-	1.417	1.632	1.763	-	3.896	-	4.753	-
69,8	60	KMG022100607	497	-	-	1.603	1.892	2.043	-	4.430	-	5.406	-
69,8	75	KMG022100757	570	-	-	1.795	2.167	2.341	-	4.970	-	6.066	-
69,8	90	KMG022100907	638	-	-	1.981	2.418	2.612	-	5.504	-	6.719	-
74,8	45	KMG022100458	449	-	-	1.468	1.704	1.840	-	4.043	-	4.933	-
74,8	60	KMG022100608	517	-	-	1.657	1.972	2.130	-	4.585	-	5.597	-
74,8	75	KMG022100758	592	-	-	1.852	2.236	2.415	-	5.133	-	6.265	-
74,8	90	KMG022100908	661	-	-	2.041	2.508	2.708	-	5.675	-	6.929	-

COLONNE A GIORNO

Open tall units
Colonnes ouvertes
Columnas abiertas
Offene Hochschranke

Colonna a giorno H. 225
Columna abierta H. 225
Colonne ouverte H. 225
Columna abierta H. 225
Offene Hochschrank H. 225

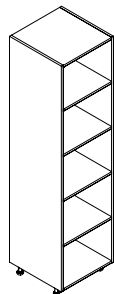

P/D	L/W	CODICE	0	1	2	3	4	5	6	7	8	9	10
36,8	45	KMG022250451	311	-	-	1.035	1.119	1.208	-	2.803	-	3.393	-
36,8	60	KMG022250601	363	-	-	1.181	1.284	1.386	-	3.224	-	3.908	-
36,8	75	KMG022250751	420	-	-	1.334	1.493	1.612	-	3.651	-	4.429	-
36,8	90	KMG022250901	471	-	-	1.481	1.690	1.825	-	4.073	-	4.944	-
59,8	45	KMG022250454	425	-	-	1.377	1.576	1.703	-	3.786	-	4.596	-
59,8	60	KMG022250604	495	-	-	1.561	1.834	1.981	-	4.316	-	5.245	-
59,8	75	KMG022250754	570	-	-	1.753	2.106	2.275	-	4.852	-	5.899	-
59,8	90	KMG022250904	635	-	-	1.937	2.357	2.546	-	5.382	-	6.548	-
64,8	45	KMG022250455	430	-	-	1.424	1.633	1.763	-	3.919	-	4.780	-
64,8	60	KMG022250605	498	-	-	1.612	1.895	2.046	-	4.457	-	5.439	-
64,8	75	KMG022250755	572	-	-	1.806	2.172	2.345	-	5.000	-	6.103	-
64,8	90	KMG022250905	641	-	-	1.993	2.426	2.620	-	5.538	-	6.762	-
69,8	45	KMG022250457	451	-	-	1.479	1.713	1.850	-	4.074	-	4.971	-
69,8	60	KMG022250607	520	-	-	1.669	1.980	2.138	-	4.620	-	5.639	-
69,8	75	KMG022250757	595	-	-	1.865	2.262	2.443	-	5.171	-	6.312	-
69,8	90	KMG022250907	664	-	-	2.056	2.520	2.721	-	5.717	-	6.981	-
74,8	45	KMG022250458	471	-	-	1.533	1.790	1.933	-	4.229	-	5.161	-
74,8	60	KMG022250608	542	-	-	1.726	2.065	2.230	-	4.783	-	5.839	-
74,8	75	KMG022250758	618	-	-	1.925	2.335	2.522	-	5.342	-	6.522	-
74,8	90	KMG022250908	688	-	-	2.118	2.613	2.823	-	5.896	-	7.200	-

Colonna a giorno H. 240
Columna abierta H. 240
Colonne ouverte H. 240
Columna abierta H. 240
Offene Hochschrank H. 240

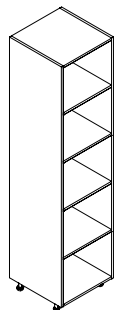

P/D	L/W	CODICE	0	1	2	3	4	5	6	7	8	9	10
36,8	45	KMG022400451	325	-	-	1.078	1.171	1.265	-	2.929	-	3.547	-
36,8	60	KMG022400601	378	-	-	1.229	1.342	1.450	-	3.362	-	4.077	-
36,8	75	KMG022400751	437	-	-	1.386	1.558	1.683	-	3.801	-	4.612	-
36,8	90	KMG022400901	490	-	-	1.537	1.762	1.903	-	4.234	-	5.142	-
59,8	45	KMG022400454	445	-	-	1.433	1.649	1.781	-	3.948	-	4.794	-
59,8	60	KMG022400604	515	-	-	1.622	1.912	2.065	-	4.490	-	5.458	-
59,8	75	KMG022400754	590	-	-	1.817	2.192	2.367	-	5.038	-	6.127	-
59,8	90	KMG022400904	660	-	-	2.006	2.450	2.646	-	5.580	-	6.790	-
64,8	45	KMG022400455	451	-	-	1.484	1.709	1.846	-	4.089	-	4.989	-
64,8	60	KMG022400605	520	-	-	1.675	1.978	2.136	-	4.639	-	5.662	-
64,8	75	KMG022400755	596	-	-	1.873	2.262	2.443	-	5.194	-	6.340	-
64,8	90	KMG022400905	666	-	-	2.065	2.523	2.725	-	5.744	-	7.013	-
69,8	45	KMG022400457	472	-	-	1.541	1.795	1.938	-	4.252	-	5.188	-
69,8	60	KMG022400607	543	-	-	1.735	2.068	2.233	-	4.810	-	5.871	-
69,8	75	KMG022400757	620	-	-	1.936	2.357	2.545	-	5.373	-	6.559	-
69,8	90	KMG022400907	691	-	-	2.130	2.621	2.831	-	5.931	-	7.242	-
74,8	45	KMG022400458	494	-	-	1.597	1.876	2.026	-	4.415	-	5.388	-
74,8	60	KMG022400608	566	-	-	1.794	2.157	2.330	-	4.981	-	6.081	-
74,8	75	KMG022400758	644	-	-	1.998	2.435	2.629	-	5.552	-	6.779	-
74,8	90	KMG022400908	716	-	-	2.195	2.720	2.937	-	6.118	-	7.471	-

Basi con maniglia
Base units with handle

Basi con gola
Base units with groove

Colonne
Tall units

Pensili
Wall units

Elementi speciali
Special elements

Maniglie gole zoccoli
Handles grooves plinth

Illuminazione
Lighting

Accessori
Accessories

Componenti e meccanismi
Components e mechanism

PENSILI A GIORNO

Open wall units
Modules suspendus ouverts
Colgantes abiertos
Offene Hängeschränke

Pensile a giorno H. 39

Colgante abierto H. 39
module suspendu ouvert H. 39
Colgante abierto H. 39
Offener Hängeschrank H. 39



P/D	L/W	CODICE	0	1	2	3	4	5	6	7	8	9	10
36,8	45	KMG030390451	87	-	-	278	300	324	-	710	-	842	-
36,8	60	KMG030390601	101	-	-	320	333	360	-	832	-	991	-
36,8	75	KMG030390751	114	-	-	362	388	419	-	953	-	1.139	-
36,8	90	KMG030390901	127	-	-	404	434	469	-	1.075	-	1.287	-
36,8	105	KMG030391051	140	-	-	447	487	526	-	1.196	-	1.435	-
36,8	120	KMG030391201	153	-	-	489	540	583	-	1.317	-	1.583	-

Pensile a giorno H. 45,5

Colgante abierto H. 45,5
module suspendu ouvert H. 45,5
Colgante abierto H. 45,5
Offener Hängeschrank H. 45,5



P/D	L/W	CODICE	0	1	2	3	4	5	6	7	8	9	10
36,8	45	KMG030450451	93	-	-	297	304	329	-	765	-	909	-
36,8	60	KMG030450601	107	-	-	341	348	376	-	892	-	1.064	-
36,8	75	KMG030450751	121	-	-	385	403	436	-	1.018	-	1.218	-
36,8	90	KMG030450901	135	-	-	429	455	492	-	1.145	-	1.372	-
36,8	105	KMG030451051	149	-	-	473	511	552	-	1.271	-	1.527	-
36,8	120	KMG030451201	163	-	-	517	567	612	-	1.398	-	1.681	-

Pensile a giorno H. 57

Colgante abierto H. 57
module suspendu ouvert H. 57
Colgante abierto H. 57
Offener Hängeschrank H. 57

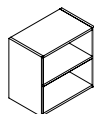

P/D	L/W	CODICE	0	1	2	3	4	5	6	7	8	9	10
36,8	45	KMG030570451	116	-	-	382	400	432	-	992	-	1.186	-
36,8	60	KMG030570601	135	-	-	443	458	495	-	1.166	-	1.398	-
36,8	75	KMG030570751	154	-	-	503	537	580	-	1.340	-	1.611	-
36,8	90	KMG030570901	174	-	-	564	611	660	-	1.514	-	1.823	-
36,8	105	KMG030571051	193	-	-	624	678	732	-	1.688	-	2.035	-
36,8	120	KMG030571201	213	-	-	684	755	815	-	1.862	-	2.248	-

PENSILI A GIORNO

Open wall units
Modules suspendus ouvertes
Colgantes abiertos
Offene Hängeschränke

Pensile a giorno H. 72

Colgante abierto H. 72
module suspendu ouvert H. 72
Colgante abierto H. 72
Offener Hängeschrank H. 72

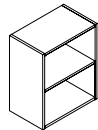

P/D	L/W	CODICE	0	1	2	3	4	5	6	7	8	9	10
36,8	45	KMG030720451	130	-	-	426	457	493	-	1.119	-	1.340	-
36,8	60	KMG030720601	151	-	-	491	521	563	-	1.304	-	1.567	-
36,8	75	KMG030720751	172	-	-	555	608	656	-	1.490	-	1.794	-
36,8	90	KMG030720901	193	-	-	620	680	734	-	1.676	-	2.021	-
36,8	105	KMG030721051	214	-	-	684	761	822	-	1.862	-	2.248	-
36,8	120	KMG030721201	235	-	-	749	839	906	-	2.047	-	2.474	-

Pensile a giorno H. 87

Colgante abierto H. 87
module suspendu ouvert H. 87
Colgante abierto H. 87
Offener Hängeschrank H. 87

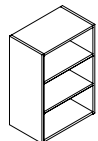

P/D	L/W	CODICE	0	1	2	3	4	5	6	7	8	9	10
36,8	45	KMG030870451	155	-	-	522	558	602	-	1.375	-	1.653	-
36,8	60	KMG030870601	182	-	-	604	642	694	-	1.611	-	1.941	-
36,8	75	KMG030870751	209	-	-	686	743	803	-	1.847	-	2.229	-
36,8	90	KMG030870901	236	-	-	768	841	909	-	2.083	-	2.517	-
36,8	105	KMG030871051	263	-	-	850	943	1.018	-	2.319	-	2.806	-
36,8	120	KMG030871201	290	-	-	931	1.049	1.133	-	2.555	-	3.094	-

Pensile a giorno H. 102

Colgante abierto H. 102
module suspendu ouvert H. 102
Colgante abierto H. 102
Offener Hängeschrank H. 102

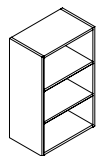

P/D	L/W	CODICE	0	1	2	3	4	5	6	7	8	9	10
36,8	45	KMG031020451	169	-	-	566	613	662	-	1.501	-	1.807	-
36,8	60	KMG031020601	197	-	-	652	697	752	-	1.749	-	2.109	-
36,8	75	KMG031020751	226	-	-	738	807	871	-	1.997	-	2.412	-
36,8	90	KMG031020901	255	-	-	824	915	989	-	2.245	-	2.715	-
36,8	105	KMG031021051	284	-	-	910	1.024	1.106	-	2.493	-	3.018	-
36,8	120	KMG031021201	312	-	-	996	1.137	1.228	-	2.740	-	3.321	-

Basi con maniglia
Base units with handle

Basi con gola
Base units with groove

Colonne
Tall units

Pensili
Wall units

Elementi speciali
Special elements

Maniglie gole zoccoli
Handles grooves plinth

Illuminazione
Lighting

Accessori
Accessories

Componenti e meccanismi
Components e mechanism

COLONNE RIENTRANTI

Pocket doors tall units
 Colonne portes rentrantes
 Pocket doors tall units
 Versenkte Hochschränke

MODULARITÀ COLONNE CON ANTE RIENTRANTI

TALL UNITS MODULARITY WITH POCKET DOORS
 MODULARITÉ DES COLONNES AVEC RENTRANTES
 MODULARIDAD DE COLUMNAS CON PUERTAS RETRACTILES
 MODULARITÄT MIT EINGELASSENEN TÜREN

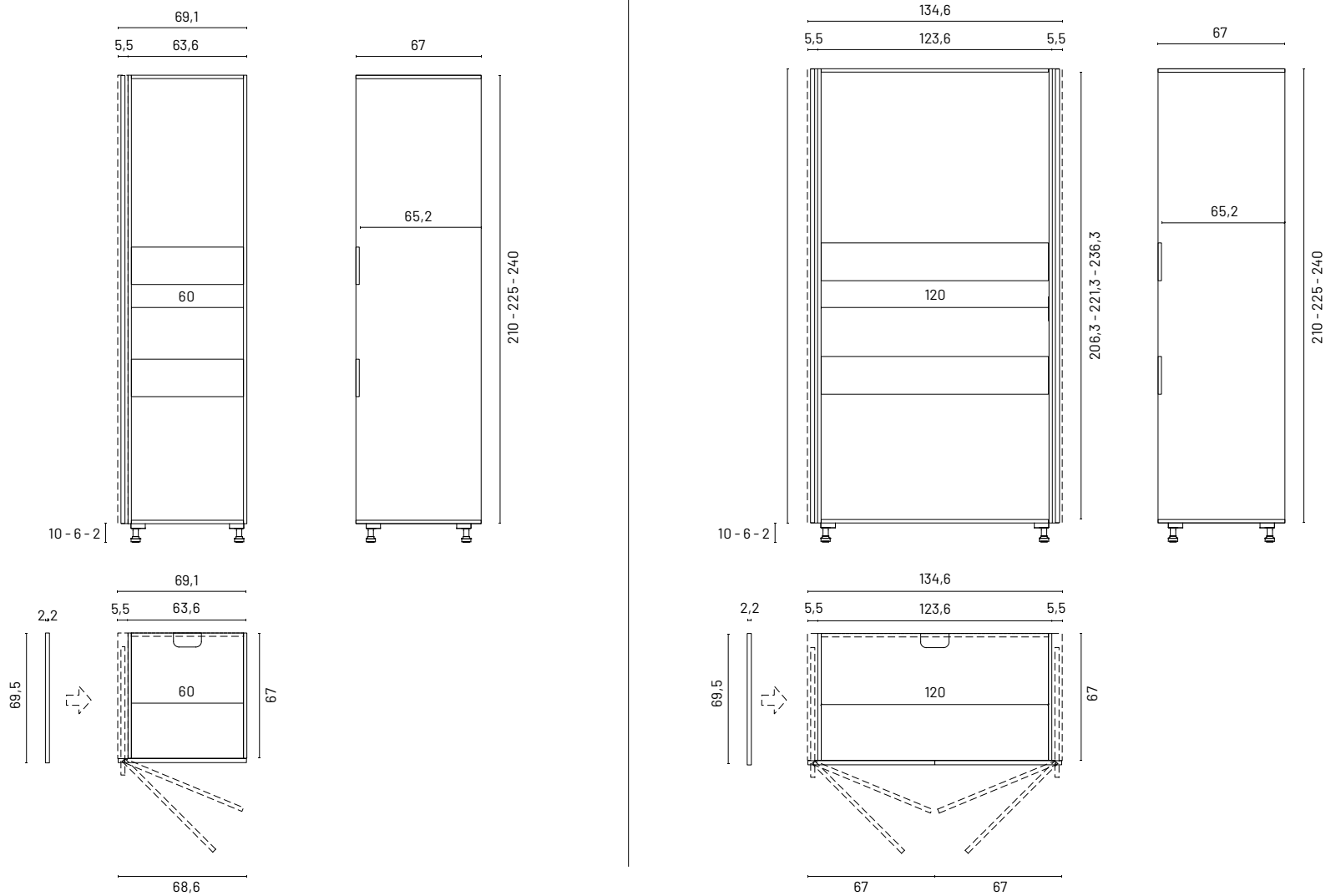

Le colonne sono fornite senza schiena. Prevedere sempre una spalla di chiusura o una colonna accostata. In presenza di ante adiacenti consigliamo di verificare le eventuali collisioni della maniglia.

Tall units are supplied without a back panel. Always provide a end side panel or juxtaposed tall unit. With adjacent fronts, we recommend checking for handle collisions.

Les colonnes sont fournies sans dos. Il faut toujours prévoir un côté de finition ou une colonne adjacente. S'il y a des portes adjacentes, il est recommandé de vérifier qu'il n'y a pas de collision possible entre les poignées.

Las columnas se suministran sin trasera. Hay que prever siempre un lateral de cierre o una columna adyacente. En presencia de puertas adyacentes se recomienda comprobar posibles colisiones del tirador. Die Schränke werden ohne Rückwand geliefert. Sehen Sie immer eine Abschlussseite oder eine andere Schrank daneben vor. Bei benachbarten Türen bitte an der Griffe beachten.

COLONNE RIENTRANTI

H. 210

Pocket doors tall units
Colonnes portes rentrantes
Pocket doors tall units
Versenkte Hochschränke

Colonna 1 anta rientrante

Tall unit with 1 pocket door
Colonne 1 porte rentrante
Column 1 puerta retráctil
Hochschrank 1 eingelassene Tür

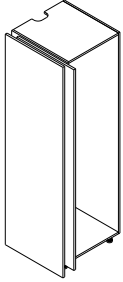

Modelli non disponibili: CX_Alumina e CX_Vidro
Models not available: CX_Alumina and CX_Vidro
Modèles non disponibles : CX_Alumina et CX_Vidro
Modelos no disponibles: CX_Alumina y CX_Vidro
Nicht verfügbare Modelle: CX_Alumina und CX_Vidro

P/D	L/W	CODICE	0	1	2	3	4	5	6	7	8	9	10
67	69	KCT012100697	1.610	1.746	1.837	1.914	2.096	2.280	2.385	2.443	2.738	2.956	3.175

1 anta dx o sx L 69 cm | vano interno L 60 cm

1 door right or left L 69 cm | inside measurement W 60 cm
1 porte à droite ou à gauche L 69 cm | compartiment interne L 60 cm
1 puerta derecha o izquierda L 69 cm | compart.interno A. 60 cm
1 Tür rechts oder links B 69 cm | innenmaß B 60 cm

Colonna 2 ante rientranti

Tall unit with 2 pocket door
Colonne avec 2 portes rentrantes
Column con 2 puertas retráctiles
Hochschrank mit 2 versenkbaren Türen

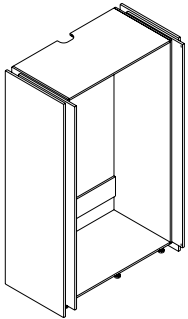

Modelli non disponibili: CX_Alumina e CX_Vidro
Models not available: CX_Alumina and CX_Vidro
Modèles non disponibles : CX_Alumina et CX_Vidro
Modelos no disponibles: CX_Alumina y CX_Vidro
Nicht verfügbare Modelle: CX_Alumina und CX_Vidro

P/D	L/W	CODICE	0	1	2	3	4	5	6	7	8	9	10
67	134,6	KCT022101347	2.919	3.188	3.355	3.525	3.891	4.373	4.558	4.584	4.945	5.601	5.820

2 ante L 67 cm | vano interno L 120 cm

2 doors W 67 cm | inside measurement W 120 cm
2 portes L 67 cm | compartiment interne L 120 cm
2 puertas L 67 cm | compart.interno A. 120 cm
2 Türen B 67 cm | innenmaß B 120 cm

Portale colonna 2 ante rientranti per cucina a scomparsa

Column door with 2 retractable kitchen doors
Porte colonne avec 2 portes de cuisine rétractables
Columna 2 puertas folding retráctiles para cocina oculta
HOCHSCHRÄNKE MIT 2 EINSCHUBTÜREN FÜR KOCHEN

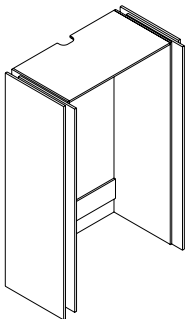

Modelli non disponibili: CX_Alumina e CX_Vidro
Models not available: CX_Alumina and CX_Vidro
Modèles non disponibles : CX_Alumina et CX_Vidro
Modelos no disponibles: CX_Alumina y CX_Vidro
Nicht verfügbare Modelle: CX_Alumina und CX_Vidro

P/D	L/W	CODICE	0	1	2	3	4	5	6	7	8	9	10
67	134,6	KCU022101347	2.919	3.188	3.355	3.525	3.891	4.373	4.558	4.584	4.945	5.601	5.820

2 ante L 67 cm | vano interno L 120 cm

2 doors W 67 cm | inside measurement W 120 cm
2 portes L 67 cm | compartiment interne L 120 cm
2 puertas L 67 cm | compart.interno A. 120 cm
2 Türen B 67 cm | innenmaß B 120 cm

Basi con maniglia
Base units with handle

Basi con gola
Base units with groove

Colonne
Tall units

Pensili
Wall units

Elementi speciali
Special elements

Maniglie gole zoccoli
Handles grooves plinth

Illuminazione
Lighting

Accessori
Accessories

Componenti e meccanismi
Components e mechanism

COLONNE RIENTRANTI

H. 225

Pocket doors tall units
Colonnes portes rentrantes
Pocket doors tall units
Versenkte Hochschranke

Colonna 1 anta rientrante

Tall unit with 1 pocket door
Colonne 1 porte rentrante
Column 1 puerta retráctil
Hochschrank 1 eingelassene Tür

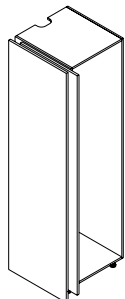

Modelli non disponibili: CX_Alumina e CX_Vidro
Models not available: CX_Alumina and CX_Vidro
Modèles non disponibles : CX_Alumina et CX_Vidro
Modelos no disponibles: CX_Alumina y CX_Vidro
Nicht verfügbare Modelle: CX_Alumina und CX_Vidro

P/D	L/W	CODICE	0	1	2	3	4	5	6	7	8	9	10
67	69	KCT012250697	1.657	1.796	1.891	1.969	2.157	2.345	2.455	2.514	2.817	3.042	3.267

1 anta dx o sx L 69 cm | vano interno L 60 cm

1 door right or left L 69 cm | inside measurement W 60 cm
1 porte à droite ou à gauche L 69 cm | compartiment interne L 60 cm
1 puerta derecha o izquierda L 69 cm | compart.interno A. 60 cm
1 Tür rechts oder links B 69 cm | innenmaß B 60 cm

Colonna 2 ante rientranti

Tall unit with 2 pocket door
Colonne avec 2 portes rentrantes
Column con 2 puertas retráctiles
Hochschrank mit 2 versenkbaeren Türen

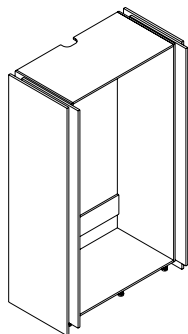

Modelli non disponibili: CX_Alumina e CX_Vidro
Models not available: CX_Alumina and CX_Vidro
Modèles non disponibles : CX_Alumina et CX_Vidro
Modelos no disponibles: CX_Alumina y CX_Vidro
Nicht verfügbare Modelle: CX_Alumina und CX_Vidro

P/D	L/W	CODICE	0	1	2	3	4	5	6	7	8	9	10
67	134,6	KCT022251347	3.004	3.282	3.453	3.628	4.004	4.500	4.691	4.718	5.089	5.764	5.989

2 ante L 67 cm | vano interno L 120 cm

2 doors W 67 cm | inside measurement W 120 cm
2 portes L 67 cm | compartiment interne L 120 cm
2 puertas L 67 cm | compart.interno A. 120 cm
2 Türen B 67 cm | innenmaß B 120 cm

Portale colonna 2 ante rientranti per cucina a scomparsa

Column door with 2 retractable kitchen doors
Porte colonne avec 2 portes de cuisine rétractables
Column 2 puertas folding retráctiles para cocina oculta
HOCHSCHRÄNKE MIT 2 EINSCHUBTÜREN FÜR KOCHEN

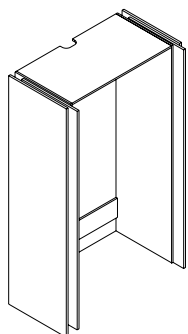

Modelli non disponibili: CX_Alumina e CX_Vidro
Models not available: CX_Alumina and CX_Vidro
Modèles non disponibles : CX_Alumina et CX_Vidro
Modelos no disponibles: CX_Alumina y CX_Vidro
Nicht verfügbare Modelle: CX_Alumina und CX_Vidro

P/D	L/W	CODICE	0	1	2	3	4	5	6	7	8	9	10
67	134,6	KCU022251347	3.004	3.282	3.453	3.628	4.004	4.500	4.691	4.718	5.089	5.764	5.989

2 ante L 67 cm | vano interno L 120 cm

2 doors W 67 cm | inside measurement W 120 cm
2 portes L 67 cm | compartiment interne L 120 cm
2 puertas L 67 cm | compart.interno A. 120 cm
2 Türen B 67 cm | innenmaß B 120 cm

COLONNE RIENTRANTI

Pocket doors tall units
Colonnes portes rentrantes
Pocket doors tall units
Versenkte Hochschränke

H. 240

Colonna 1 anta rientrante

Tall unit with 1 pocket door
Colonne 1 porte rentrante
Column 1 puerta retráctil
Hochschrank 1 eingelassene Tür

Modelli non disponibili: CX_Alumina e CX_Vidro
Models not available: CX_Alumina and CX_Vidro
Modèles non disponibles : CX_Alumina et CX_Vidro
Modelos no disponibles: CX_Alumina y CX_Vidro
Nicht verfügbare Modelle: CX_Alumina und CX_Vidro

P/D	L/W	CODICE	0	1	2	3	4	5	6	7	8	9	10
67	69	KCT012400697	1.707	1.851	1.948	2.028	2.222	2.416	2.529	2.590	2.902	3.134	3.366

1 anta dx o sx L 69 cm | vano interno L 60 cm

1 door right or left L 69 cm | inside measurement W 60 cm
1 porte à droite ou à gauche L 69 cm | compartiment interne L 60 cm
1 puerta derecha o izquierda L 69 cm | compart.interno A. 60 cm
1 Tür rechts oder links B 69 cm | innenmaß B 60 cm

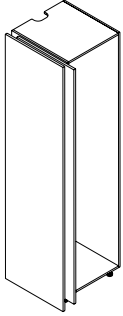

Colonna 2 ante rientranti

Tall unit with 2 pocket door
Colonne avec 2 portes rentrantes
Column con 2 puertas retráctiles
Hochschrank mit 2 versenkbaren Türen

Modelli non disponibili: CX_Alumina e CX_Vidro
Models not available: CX_Alumina and CX_Vidro
Modèles non disponibles : CX_Alumina et CX_Vidro
Modelos no disponibles: CX_Alumina y CX_Vidro
Nicht verfügbare Modelle: CX_Alumina und CX_Vidro

P/D	L/W	CODICE	0	1	2	3	4	5	6	7	8	9	10
67	134,6	KCT022401347	3.094	3.380	3.557	3.737	4.124	4.636	4.833	4.860	5.474	5.937	6.401

2 ante L 67 cm | vano interno L 120 cm

2 doors W 67 cm | inside measurement W 120 cm
2 portes L 67 cm | compartiment interne L 120 cm
2 puertas L 67 cm | compart.interno A. 120 cm
2 Türen B 67 cm | innenmaß B 120 cm

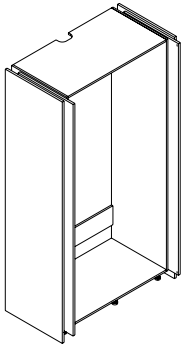

Portale colonna 2 ante rientranti per cucina a scomparsa

Column door with 2 retractable kitchen doors
Porte colonne avec 2 portes de cuisine rétractables
Columna 2 puertas folding retráctiles para cocina oculta
HOCHSCHRÄNKE MIT 2 EINSCHUBTÜREN FÜR KOCHEN

Modelli non disponibili: CX_Alumina e CX_Vidro
Models not available: CX_Alumina and CX_Vidro
Modèles non disponibles : CX_Alumina et CX_Vidro
Modelos no disponibles: CX_Alumina y CX_Vidro
Nicht verfügbare Modelle: CX_Alumina und CX_Vidro

P/D	L/W	CODICE	0	1	2	3	4	5	6	7	8	9	10
67	134,6	KCU022401347	3.094	3.380	3.557	3.737	4.124	4.636	4.833	4.860	5.474	5.937	6.401

2 ante L 67 cm | vano interno L 120 cm

2 doors W 67 cm | inside measurement W 120 cm
2 portes L 67 cm | compartiment interne L 120 cm
2 puertas L 67 cm | compart.interno A. 120 cm
2 Türen B 67 cm | innenmaß B 120 cm

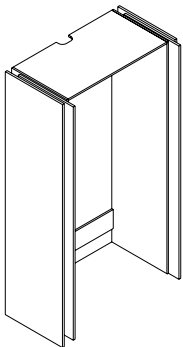

Basi con maniglia
Base units with handle

Basi con gola
Base units with groove

Colonne
Tall units

Pensili
Wall units

Elementi speciali
Special elements

Maniglie gole zoccoli
Handles grooves plinth

Illuminazione
Lighting

Accessori
Accessories

Componenti e meccanismi
Components e mechanism

COLONNE FOLDING

Folding tall units
Colonnes folding
Folding tall units
Klappbare Hochschränke

PORTALE CON ANTE FOLDING

PORTAL WITH FOLDING DOORS
PORTAILS AVEC PORTES PLIANTES
PORTALES CON PUERTAS PLEGABLES
PORTALKOMPOSITIONEN MIT FALTTÜREN

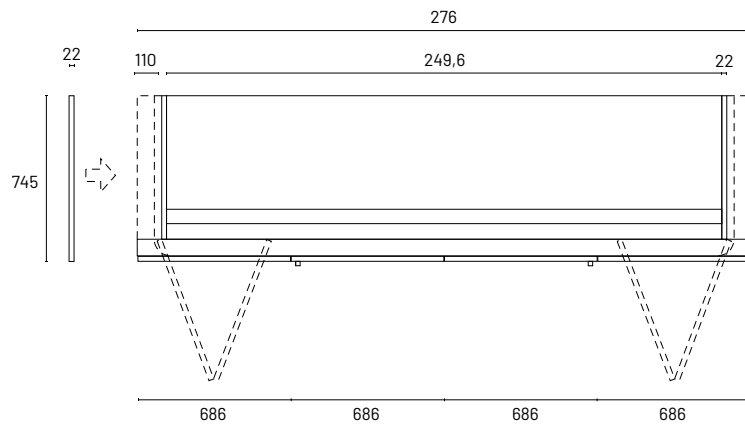

Le colonne sono fornite senza schiena. Prevedere sempre una spalla di chiusura o una colonna accostata. In presenza di ante adiacenti consigliamo di verificare le eventuali collisioni della maniglia.

Tall units are supplied without a back panel. Always provide a end side panel or juxtaposed tall unit. With adjacent fronts, we recommend checking for handle collisions.

Les colonnes sont fournies sans dos. Il faut toujours prévoir un côté de finition ou une colonne adjacente. S'il y a des portes adjacentes, il est recommandé de vérifier qu'il n'y a pas de collision possible entre les poignées.

Las columnas se suministran sin trasera. Hay que prever siempre un lateral de cierre o una columna adyacente. En presencia de puertas adyacentes se recomienda comprobar posibles colisiones del tirador.

Die Schränke werden ohne Rückwand geliefert. Sehen Sie immer eine Abschlussseite oder eine andere Schrank daneben vor. Bei benachbarten Türen bitte an der Griffe beachten.

COLONNE FOLDING

Folding tall units
 Colonne folding
 Folding tall units
 Klappbare Hochschränke

ESEMPI COMPOSIZIONI PORTALE CON ANTE FOLDING

EXAMPLES PORTAL COMPOSITIONS WITH FOLDING DOORS
 EXEMPLES DE COMPOSITIONS DE PORTAILS AVEC PORTES PLIANTES
 EJEMPLOS DE COMPOSICIONES CON PORTALES CON PUERTAS PLEGABLES
 BEISPIELE FÜR PORTALKOMPOSITIONEN MIT FALTTÜREN

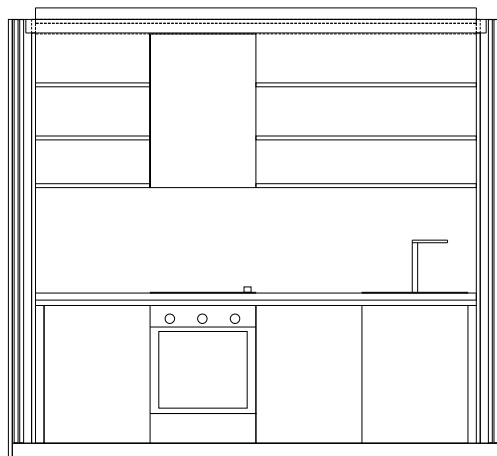
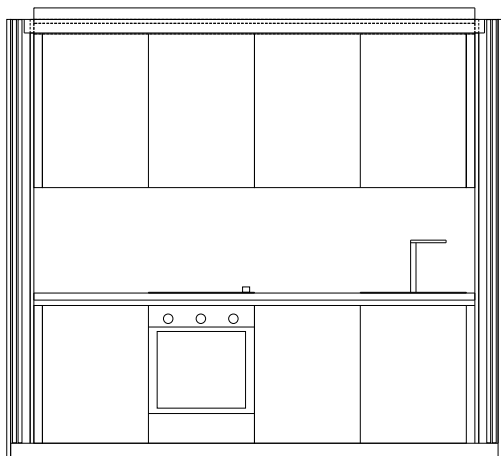
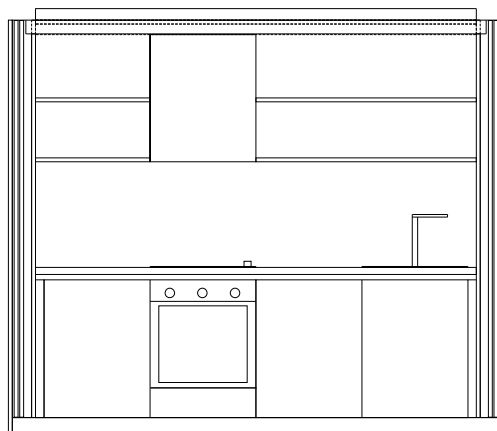
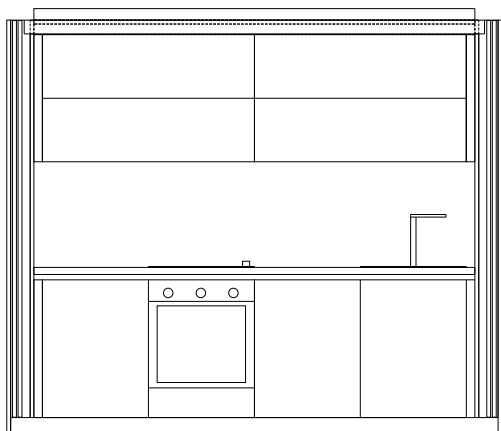
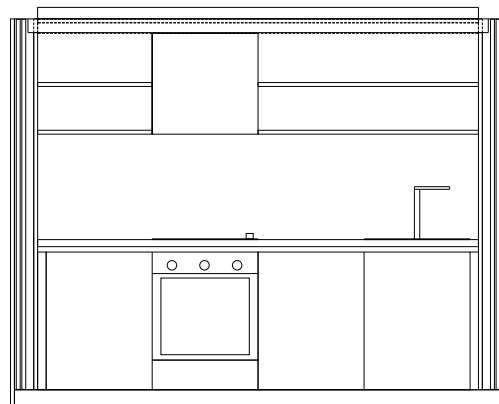
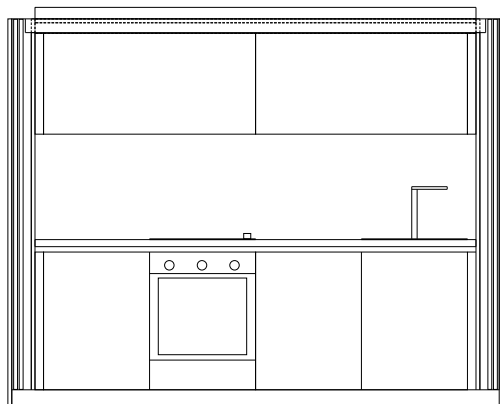

Basi con maniglia
 Base units with handle

Basi con gola
 Base units with groove

Colonne
 Tall units

Pensili
 Wall units

Elementi speciali
 Special elements

Maniglie gole zoccoli
 Handles grooves plinth

Illuminazione
 Lighting

Accessori
 Accessories

Componenti e meccanismi
 Components e mechanism

COLONNE FOLDING

Folding tall units
Colonne folding
Folding tall units
Klappbare Hochschranke

Portale colonna 4 ante folding per cucina a scomparsa H. 210

4-door folding column door for concealed kitchen H. 210
Porte colonne pliante à 4 portes pour cuisine cachée H 210
Columna 4 puertas folding para cocina oculta H 210
Hochschranke 4 Falttüren für verdeckte Küche H 210

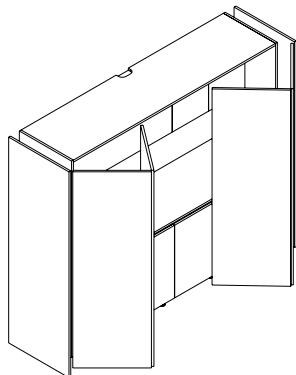

Modelli non disponibili: CX_Alumina e CX_Vidro
Models not available: CX_Alumina and CX_Vidro
Modèles non disponibles : CX_Alumina et CX_Vidro
Modelos no disponibles: CX_Alumina y CX_Vidro
Nicht verfügbare Modelle: CX_Alumina und CX_Vidro

P/D	L/W	CODICE	0	1	2	3	4	5	6	7	8	9	10
72	276	KCU082102767	5.895	6.435	6.773	7.109	7.841	8.805	9.037	9.228	10.388	11.263	12.138

4 ante L 69 cm | vano interno L 249,6 cm
4 doors W 69 cm | internal measurement W 249,6 cm
4 portes L 69 cm | compartiment interne L 249,6 cm
4 puertas L 69 cm | compart.interno A. 249,6 cm
4 Türen L 69 cm | innenmaß B249,6 cm

Portale colonna 2 ante folding per cucina a scomparsa H. 225

Column door 2 folding doors for concealed kitchen H. 225
Porte colonne 2 portes pliantes pour cuisine cachée H 225
Columna 2 puertas folding para cocina oculta H 225
Hochschranke 2 Falttüren für verdeckte Küche H 225

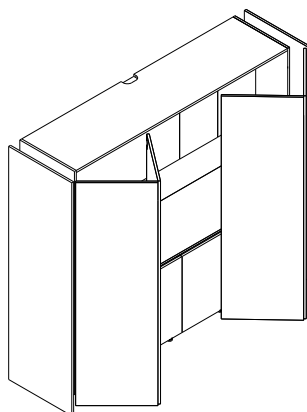

Modelli non disponibili: CX_Alumina e CX_Vidro
Models not available: CX_Alumina and CX_Vidro
Modèles non disponibles : CX_Alumina et CX_Vidro
Modelos no disponibles: CX_Alumina y CX_Vidro
Nicht verfügbare Modelle: CX_Alumina und CX_Vidro

P/D	L/W	CODICE	0	1	2	3	4	5	6	7	8	9	10
72	276	KCU082252767	6.066	6.622	6.969	7.316	8.068	9.061	9.300	9.496	10.691	11.591	12.492

4 ante L 69 cm | vano interno L 249,6 cm
4 doors W 69 cm | internal measurement W 249,6 cm
4 portes L 69 cm | compartiment interne L 249,6 cm
4 puertas L 69 cm | compart.interno A. 249,6 cm
4 Türen L 69 cm | innenmaß B249,6 cm

Portale colonna 2 ante folding per cucina a scomparsa H. 240

Column door 2 doors folding for kitchen H. 240
Porte colonne 2 portes pliantes pour cuisine cachée H. 240
Columna 2 puertas folding para cocina oculta H 240
Hochschranke 2 Falttüren für verdeckte Küche H. 240

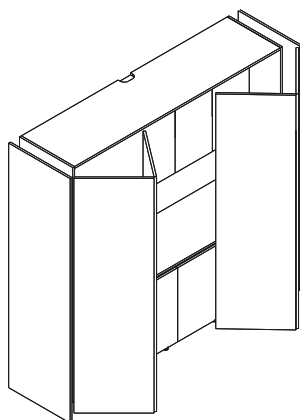

Modelli non disponibili: CX_Alumina e CX_Vidro
Models not available: CX_Alumina and CX_Vidro
Modèles non disponibles : CX_Alumina et CX_Vidro
Modelos no disponibles: CX_Alumina y CX_Vidro
Nicht verfügbare Modelle: CX_Alumina und CX_Vidro

P/D	L/W	CODICE	0	1	2	3	4	5	6	7	8	9	10
72	276	KCU082402767	6.537	7.093	7.440	7.786	8.539	9.531	9.771	9.967	11.176	12.076	12.977

4 ante L 69 cm | misura interna L 249,6 cm
4 doors W 69 cm | internal measurement W 249,6 cm
4 portes L 69 cm | mesure interne L 249,6 cm
4 puertas L 69 cm | medida interna L 249,6 cm
4 Türen L 69 cm | Innenbreite 249,6 cm

CASSETTI ESTERNI

External drawers
Tiroirs extérieurs
Externe Schubladen
Cajones exteriores

I cassetti esterni possono essere fissati sopra una base ma non sovrapposti tra di loro. La struttura del cassetto è sempre in finitura melaminica come le scocche (cenere, grafite). Il frontale non ha maniglia e l'apertura avviene tramite prensilità grazie allo spazio vuoto superiore. Il cassetto è dotato di guide ad estrazione totale complete di rallentatore Blumotion integrato, dotate di 3 regolazioni.

Exterior drawers can be attached above a base but not stacked on top of each other. The drawer frame is always in melamine finish like the shells (ash, graphite). The front has no handle, and opening is by prehension thanks to the upper gap. The drawer has full-extension runners complete with integrated Blumotion slow motion, equipped with 3 adjustments.

Les tiroirs extérieurs peuvent être fixés au-dessus d'une base mais ne peuvent pas être empilés les uns sur les autres. La structure des tiroirs est toujours en mélaminé comme les coques (frêne, graphite). La façade n'a pas de poignée et s'ouvre par préhension grâce à l'espace vide supérieur. Le tiroir est équipé de coulisses à sortie totale avec ralentissement Blumotion intégré, avec 3 réglages.

Los cajones exteriores pueden fijarse sobre una base, pero no apilarse unos sobre otros. La estructura de los cajones es siempre en acabado melaminico como las conchas (fresno, grafito). El frente no tiene tirador y se abre por prehensión gracias al espacio vacío superior. El cajón está equipado con guías de extracción total con movimiento lento Blumotion integrado, con 3 regulaciones.

Die äußeren Schubladen können über einem Sockel befestigt werden, aber nicht übereinander gestapelt werden. Die Schubladenstruktur ist wie die Schalen immer melaminharzbeschichtet (Esche, Graphit). Die Vorderseite hat keinen Griff und wird dank des oberen Leerraums durch Vorspannen geöffnet. Die Schublade ist mit Vollauszügen mit integrierter Blumotion-Slow-Motion ausgestattet, die sich in 3 Stufen einstellen lassen.

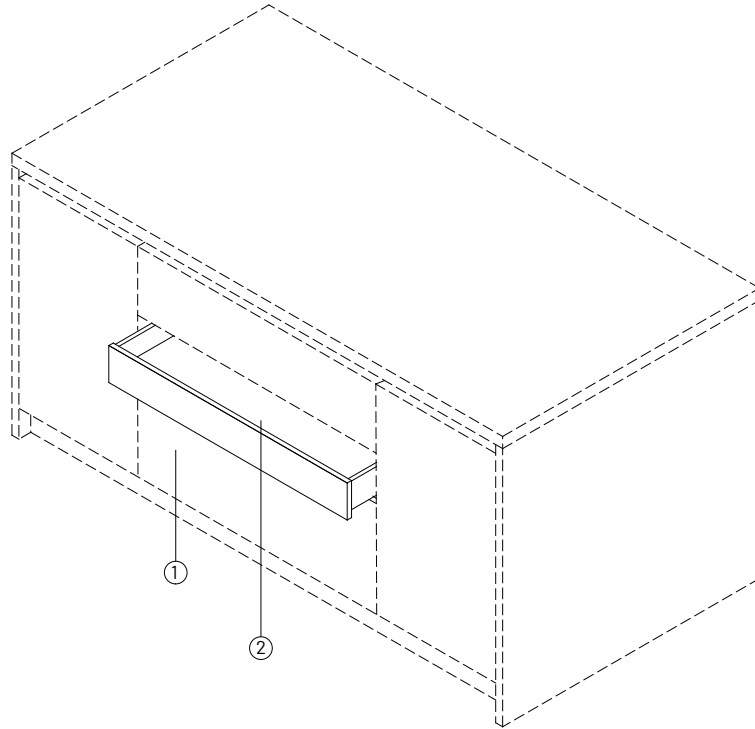

1. Base | Base | Base | Base | Basis

2. Cassetto esterno | External drawer | Tiroir extérieur | Cajón exterior | Externe Schublade

FINITURE
FINISHES
FINITIONS
ACABADOS
AUSFÜHRUNG

FASCIA DI PREZZO
PRICE RANGE
CATÉGORIE DE PRIX
CATEGORÍA DE PRECIO
PREISKLASSE

- LACCATO OPACO | MATT LACQUER**
 010 Bianco, 000 Panna, 001 Crema, 002 Grigio Perla, 003 Grigio Seta, 004 Corda, 005 Moka, 006 Blu Cobalto, 007 Grigio Aston, 008 Grigio Antracite, 009 Nero
- ESSENZA 1 | WOOD 1**
 ER0 Rovere Visone, ER1 Rovere Castoro, ER2 Rovere Carbone, ER3 Rovere Cenere
- ESSENZA 2 | WOOD 2**
 EE0 Noce Canaletto, EE1 Rovere Termotrattato
- LACCATO METALLO | LACQUERED METAL**
 L00 Ottone, L01 Acciaio, L02 Bronzo
 LS0 Oro, LS1 Ottone, LS2 Bronzo scuro, LS3 Titanio
 LA0 Ottone, LA1 Bronzo scuro, LA2 Silicio

A

A

B

A

Basi con maniglia
Base units with handle

Basi con gola
Base units with groove

Colonne
Tall units

Pensili
Wall units

Elementi speciali
Special elements

Maniglie gole zoccoli
Handles grooves plinth

Illuminazione
Lighting

Accessori
Accessories

Componenti e meccanismi
Components e mechanism

CASSETTI ESTERNI

External drawers
Tiroirs extérieurs
Externe Schubladen
Cajones exteriores

Cassetto esterno laccato opaco

Matt lacquered outer drawer
Tiroir extérieur laqué mat
Cajón exterior lacado mate
Matt lackierte Außenschublade

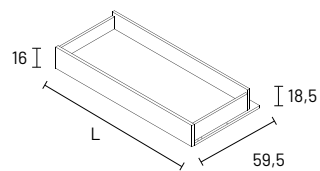

P/D	L/W	CODICE	PUNTI A
59,5	60	KSC060605018	195
59,5	75	KSC060755018	210
59,5	90	KSC060905018	226
59,5	105	KSC06105518	241
59,5	120	KSC061205018	258

Cassetto esterno Laccato Metallo

Metal lacquered outer drawer
Tiroir extérieur Métal laqué
Cajón exterior Metal lacado
Externe Schublade Lackiertes Metall

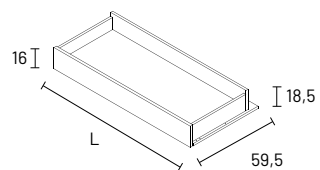

P/D	L/W	CODICE	PUNTI A
59,5	60	KSC070605018	318
59,5	75	KSC070755018	384
59,5	90	KSC070905018	446
59,5	105	KSC071055018	521
59,5	120	KSC071205018	586

Cassetto esterno Essenza 1-2

Wooden 1-2 outer drawer
Tiroir externe Essence 1-2
Cajón exterior Esencia 1-2
Externe Schublade Essenz 1-2

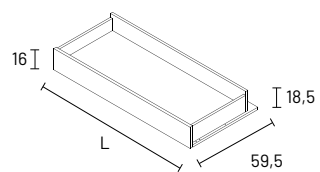

P/D	L/W	CODICE	PUNTI A	PUNTI B
59,5	60	KSC080605018A	675	-
59,5	75	KSC080755018A	696	-
59,5	90	KSC080905018A	861	-
59,5	105	KSC081055018A	996	-
59,5	120	KSC081205018A	1.044	-
59,5	60	KSC080605018B	-	714
59,5	75	KSC080755018B	-	813
59,5	90	KSC080905018B	-	912
59,5	105	KSC08155018B	-	1.010
59,5	120	KSC081205018B	-	1.110

MANIGLIE, PRESE, GOLE, ZOCCOLI

Handles, grip, groove, plinths
Poignées, prises, plinthes
Tiradores, tomas, uñeros, zócalos
Griffe, Steckdosen, Sockelleisten

MANIGLIE Handles Poignées Tiradores Griffe	P. 261
<ul style="list-style-type: none">• MANIGLIA M01 Handle M01 Poignée M01 Tirador M01 Griff M01• MANIGLIA M02 Handle M02 Poignée M02 Tirador M02 Griff M02• MANIGLIA M03 Handle M03 Poignée M03 Tirador M03 Griff M03• MANIGLIA M04 M04 Handle Poignée M04 Tirador M04 Griff M04• MANIGLIA INSIDE INSIDE Handle Poignée INSIDE Tirador INSIDE Griff INSIDE	P. 262 P. 264 P. 266 P. 268 P. 270
PRESE Grip Prises Tomas de corriente Prises	P. 272
GOLE Gorge Rainures Uñeros Rainures	P. 276
ZOCCOLI Clogs Plinthe Zócalos Sockel	P. 287

Basi con maniglia
Base units with handle

Basi con gola
Base units with groove

Colonne
Tall units

Pensili
Wall units

Elementi speciali
Special elements

Maniglie gole zoccoli
Handles grooves plinth

Illuminazione
Lighting

Accessori
Accessories

Componenti e meccanismi
Components e mechanism

MANIGLIA M01

Handle M01
Poignée M01
Tirador M01
Griff M01

Maniglia M01 in zama verniciata

M01 handle in painted zamak
Poignée M01 en zamak peint
Asa M01 de zamak pintado
Handgriff M01 aus lackiertem Zamak



	FINITURE	L/W	CODICE	PUNTI
A	Nero opaco	35,3	KMAN0402AN	12
	Perla satinato	35,3	KMAN0402AP	15
B	Nero opaco	22,5	KMAN0402BN	9
	Perla satinato	22,5	KMAN0402BP	12
C	Nero opaco	13,4	KMAN0402CN	7
	Perla satinato	13,4	KMAN0402CP	8

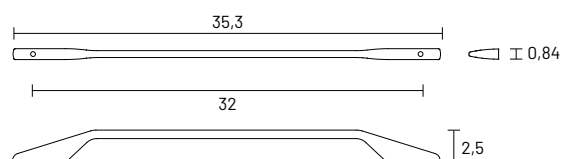

Tipologia A - interasse 32 cm

Type A - wheelbase 32 cm
Type A - entraxe 32 cm
Tipo A - distancia entre ejes 32 cm
Typ A - Abstand 32 cm

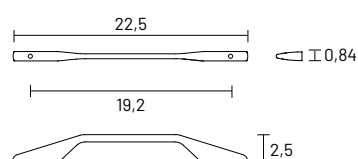

Tipologia B - interasse 19,2 cm

Type B - wheelbase 19,2 cm
Type B - entraxe 19,2 cm
Tipo B - distancia entre ejes 19,2 cm
Typ B - Abstand 19,2 cm

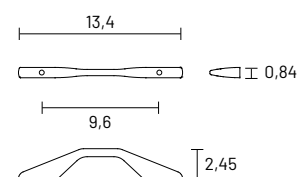

Tipologia C - interasse 9,6 cm

Type C - wheelbase 9,6 cm
Type C - entraxe 9,6 cm
Tipo C - distancia entre ejes 9,6 cm
Typ C - Abstand 9,6 cm

POSIZIONAMENTI MANIGLIE

Handle placements
Positionnement des poignées
Posicionamiento tiradores
Griffe positionieren

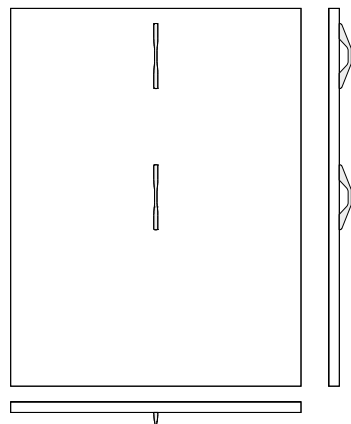

Posizionamento verticale

Vertical positioning
Positionnement vertical
Posicionamiento vertical
Vertikale Positionierung

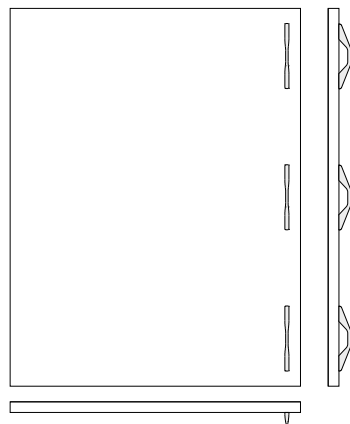

Posizionamento verticale laterale

Lateral vertical positioning
Positionnement latéral vertical
Posicionamiento vertical lateral
Vertikale seitliche Positionierung

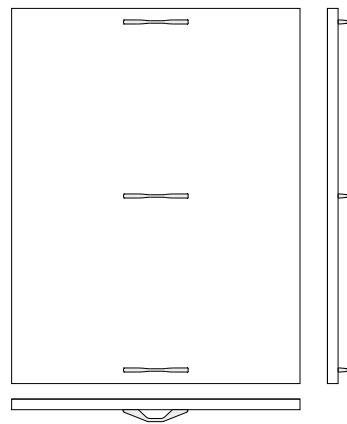

Posizionamento orizzontale

Horizontal positioning
Positionnement horizontal
Posicionamiento horizontal
Horizontale Positionierung

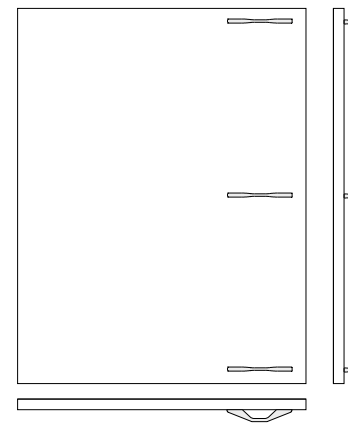

Posizionamento orizzontale laterale

Horizontal lateral positioning
Positionnement latéral horizontal
Posicionamiento horizontal lateral
Horizontale seitliche Positionierung

MANIGLIA M01

Handle M01
Poignée M01
Tirador M01
Griff M01

ESEMPIO COMPOSITIVO MANIGLIE VERTICALI

Composition example vertical handles
Exemple de composition poignées verticales
Ejemplo de composición tiradores verticales
Kompositionsbeispiel vertikale Griffe

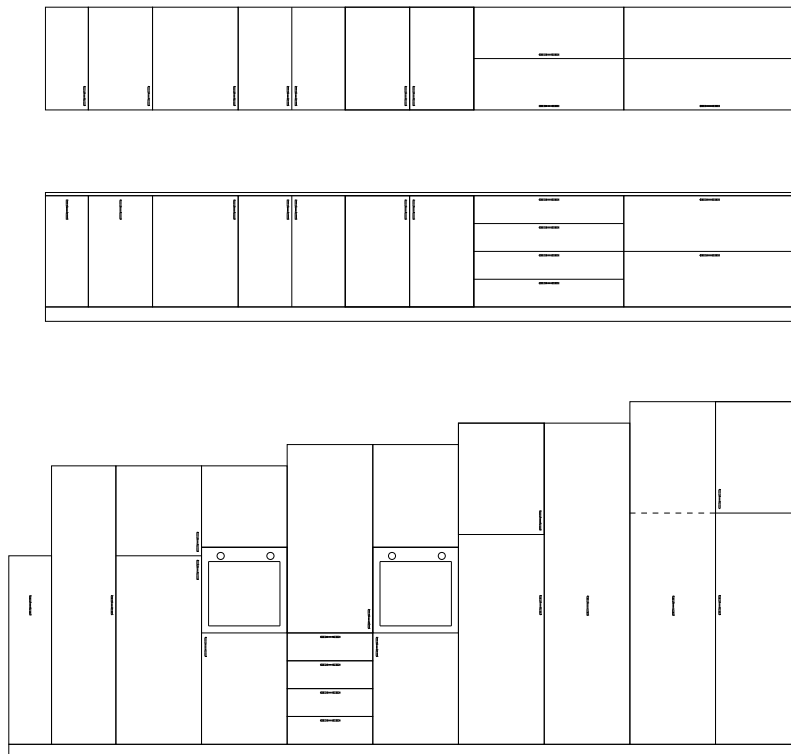

ESEMPIO COMPOSITIVO MANIGLIE ORIZZONTALI

Compositional example horizontal handles
Exemple de composition poignées horizontales
Ejemplo de composición tiradores horizontales
Kompositionsbeispiel horizontale Griffe

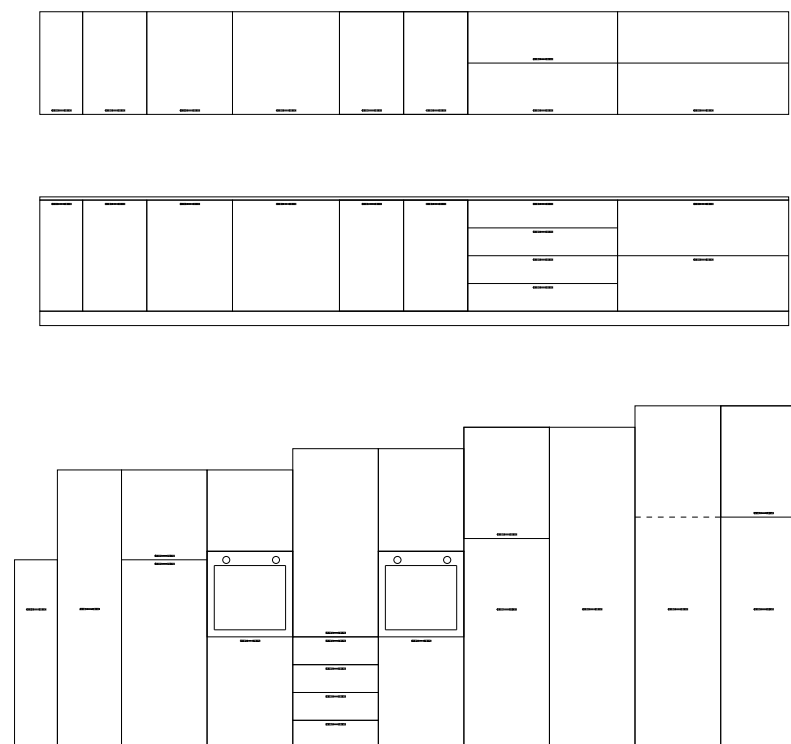

Basi con maniglia
Base units with handle

Basi con gola
Base units with groove

Colonne
Tall units

Pensili
Wall units

Elementi speciali
Special elements

Maniglie gole zoccoli
Handles grooves plinth

Illuminazione
Lighting

Accessori
Accessories

Componenti e meccanismi
Components e mechanism

MANIGLIA M02

Handle M02
Poignée M02
Tirador M02
Griff M02

Maniglia M02 in zama verniciata

M02 handle in painted zamak
Poignée M02 en zamak peint
Asa M02 de zamak pintado
Handgriff M02 aus lackiertem Zamak

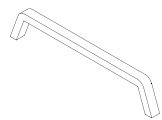

	FINITURE	L/W	CODICE	PUNTI
A	Nero opaco	32,9	KMAN0412AN	12
	Perla satinato	32,9	KMAN0412AP	17
B	Nero opaco	16,9	KMAN0412BN	9
	Perla satinato	16,9	KMAN0412BP	13
C	Nero opaco	10,5	KMAN0412CN	7
	Perla satinato	10,5	KMAN0412CP	10

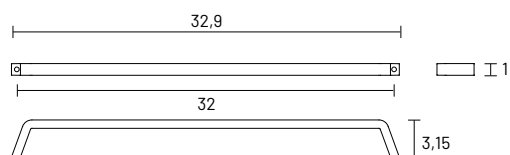

Tipologia A - interasse 32 cm

Type A - wheelbase 32 cm
Type A - entraxe 32 cm
Tipo A - distancia entre ejes 32 cm
Typ A - Abstand 32 cm

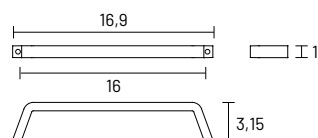

Tipologia B - interasse 16 cm

Type B - spacing 16 cm
Type B - entraxe 16 cm
Tipo B - distancia entre ejes 16 cm
Typ B - Abstand 16 cm

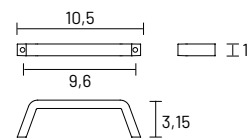

Tipologia C - interasse 9,6 cm

Type C - wheelbase 9,6 cm
Type C - entraxe 9,6 cm
Tipo C - distancia entre ejes 9,6 cm
Typ C - Abstand 9,6 cm

POSIZIONAMENTI MANIGLIE

Handle placements
Positionnement des poignées
Posicionamiento tiradores
Griffe positionieren

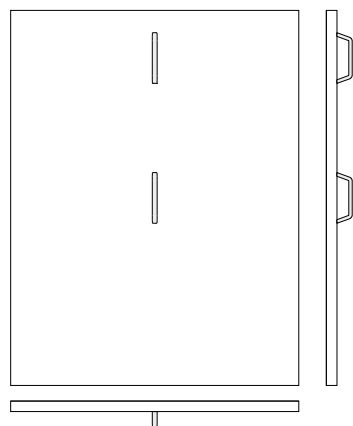

Posizionamento verticale

Vertical positioning
Positionnement vertical
Posicionamiento vertical
Vertikale Positionierung

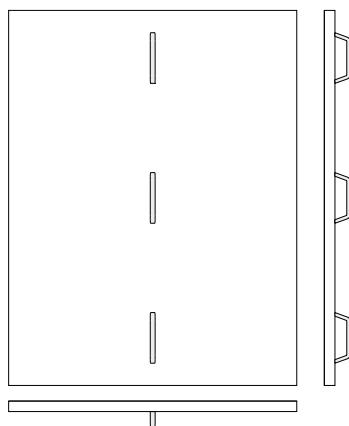

Posizionamento verticale laterale

Lateral vertical positioning
Positionnement latéral vertical
Posicionamiento vertical lateral
Vertikale seitliche Positionierung

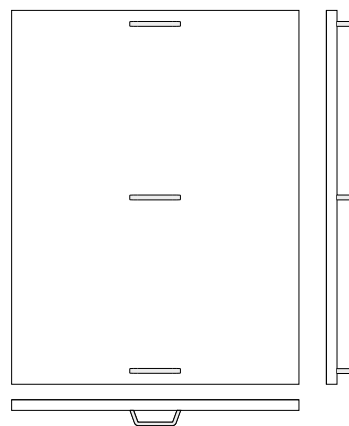

Posizionamento orizzontale

Horizontal positioning
Positionnement horizontal
Posicionamiento horizontal
Horizontale Positionierung

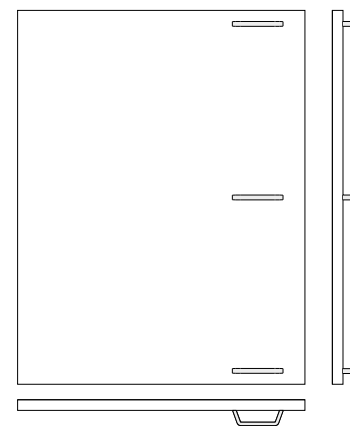

Posizionamento orizzontale laterale

Horizontal lateral positioning
Positionnement latéral horizontal
Posicionamiento horizontal lateral
Horizontale seitliche Positionierung

MANIGLIA M02

Handle M02
Poignée M02
Tirador M02
Griff M02

ESEMPIO COMPOSITIVO MANIGLIE VERTICALI

Composition example vertical handles
Exemple de composition poignées verticales
Ejemplo de composición tiradores verticales
Kompositionsbeispiel vertikale Griffe

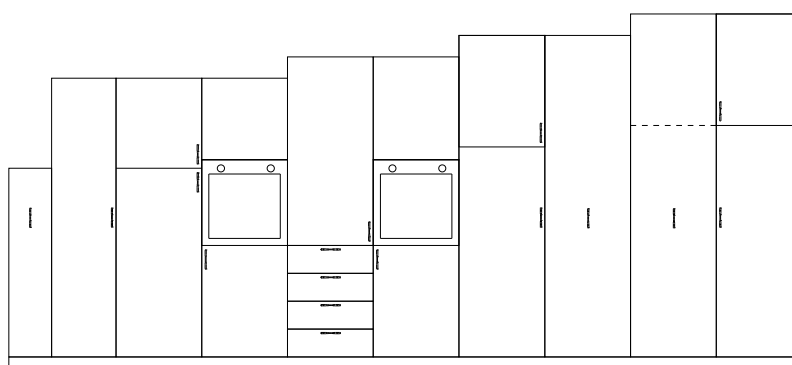
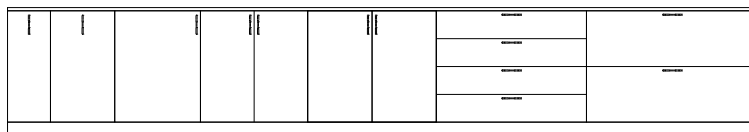
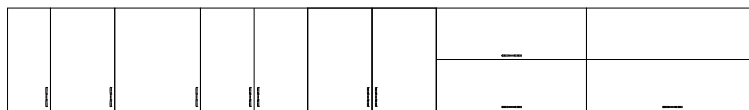

ESEMPIO COMPOSITIVO MANIGLIE ORIZZONTALI

Compositional example horizontal handles
Exemple de composition poignées horizontales
Ejemplo de composición tiradores horizontales
Kompositionsbeispiel horizontale Griffe

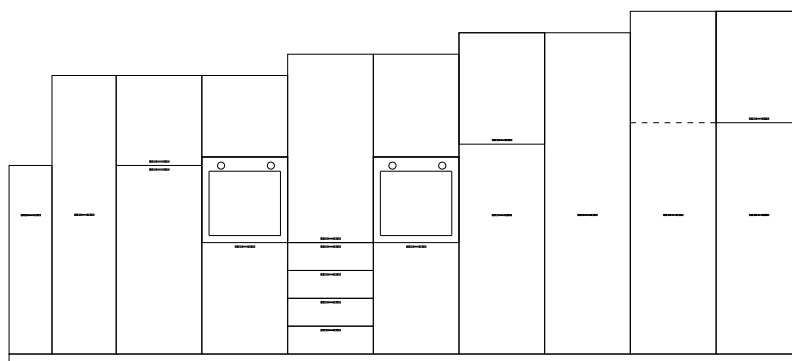
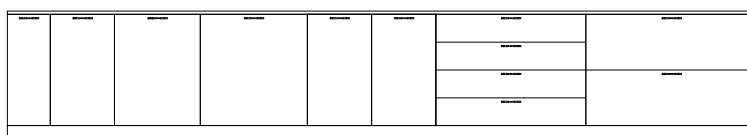
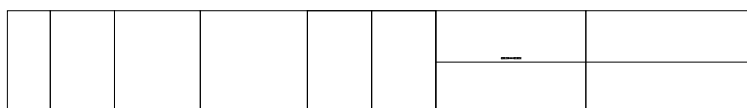

Basi con maniglia
Base units with handle

Basi con gola
Base units with groove

Colonne
Tall units

Pensili
Wall units

Elementi speciali
Special elements

Maniglie gole zoccoli
Handles grooves plinth

Illuminazione
Lighting

Accessori
Accessories

Componenti e meccanismi
Components e mechanism

MANIGLIA M03

Handle M03
Poignée M03
Tirador M03
Griff M03

Maniglia M03 con supporto in zama - tubo metallo godronato

Handle M03 with zamak holder - knurled metal tube
Poignée M03 avec support en zamak - tube métallique moleté
Empuñadura M03 con soporte de zamak - tubo metálico moleteado
Griff M03 mit Zamakhalter - gerändeltes Metallrohr

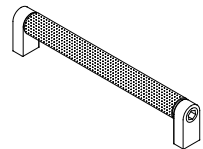

	FINITURE	L/W	CODICE	PUNTI
A	Nero opaco	65,2	KMAN0416CN	30
B	Nero opaco	36,5	KMAN0416BN	41
C	Nero opaco	20,4	KMAN0416AN	73

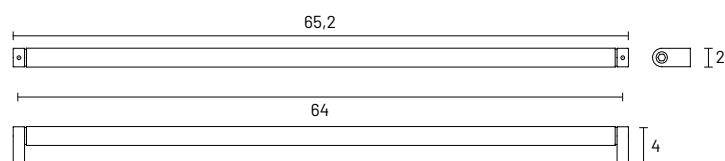

Tipologia A - interasse 64 cm

Type A - wheelbase 64 cm
Type A - entraxe 64 cm
Tipo A - distancia entre ejes 64 cm
Typ A - Abstand 64 cm

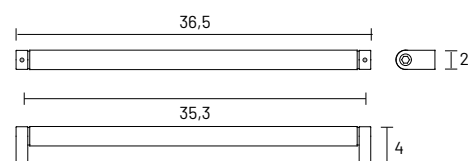

Tipologia B - interasse 35,3 cm

Type B - wheelbase 35,3 cm
Type B - entraxe 35,3 cm
Tipo B - distancia entre ejes 35,3 cm
Typ B - Abstand 35,3 cm

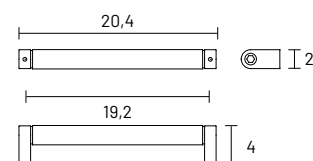

Tipologia C - interasse 19,2 cm

Type C - wheelbase 19,2 cm
Type C - entraxe 19,2 cm
Tipo C - distancia entre ejes 19,2 cm
Typ C - Abstand 19,2 cm

POSIZIONAMENTI MANIGLIE

Handle placements
Positionnement des poignées
Posicionamiento tiradores
Griffe positionieren

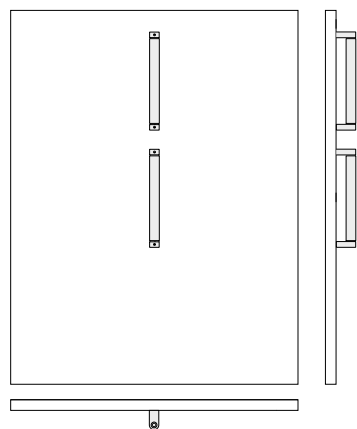

Posizionamento verticale

Vertical positioning
Positionnement vertical
Posicionamiento vertical
Vertikale Positionierung

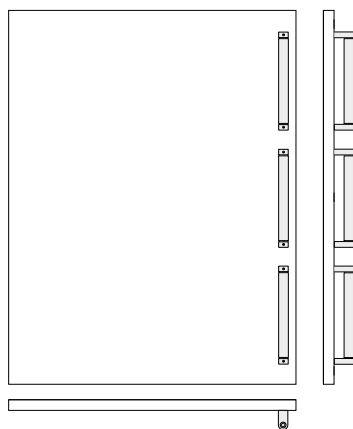

Posizionamento verticale laterale

Lateral vertical positioning
Positionnement latéral vertical
Posicionamiento vertical lateral
Vertikale seitliche Positionierung

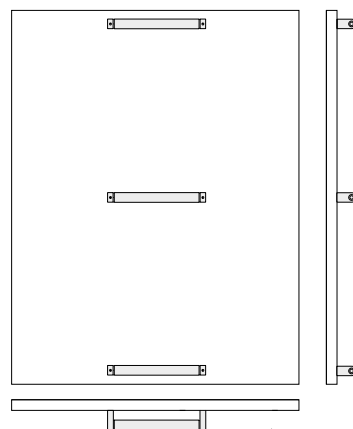

Posizionamento orizzontale

Horizontal positioning
Positionnement horizontal
Posicionamiento horizontal
Horizontale Positionierung

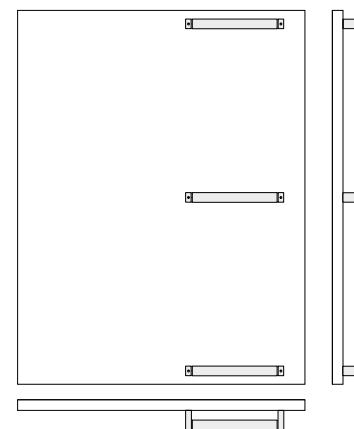

Posizionamento orizzontale laterale

Horizontal lateral positioning
Positionnement latéral horizontal
Posicionamiento horizontal lateral
Horizontale seitliche Positionierung

MANIGLIA M03

Handle M03
Poignée M03
Tirador M03
Griff M03

ESEMPIO COMPOSITIVO MANIGLIE VERTICALI

Composition example vertical handles
Exemple de composition poignées verticales
Ejemplo de composición tiradores verticales
Kompositionsbeispiel vertikale Griffe

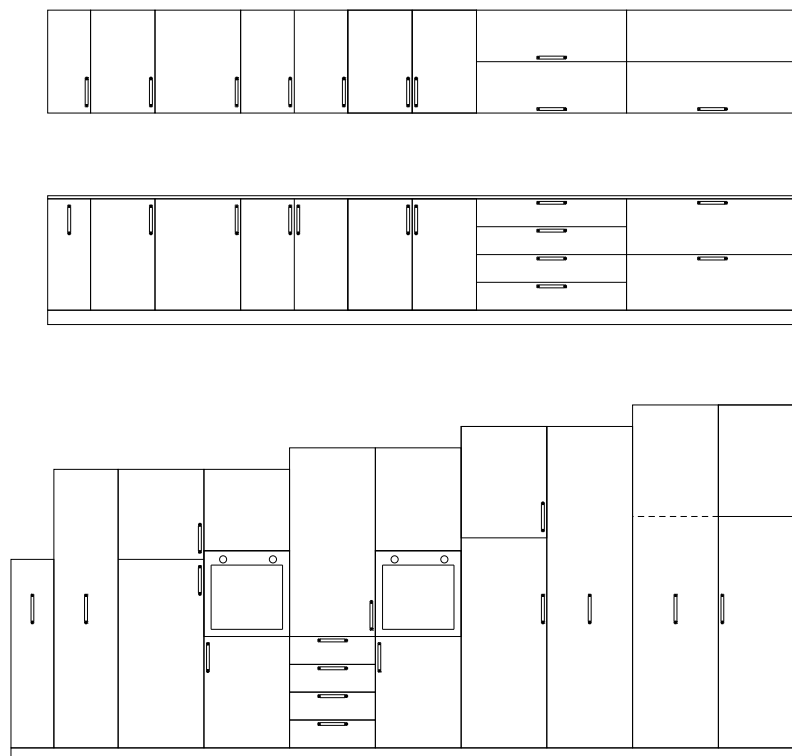

ESEMPIO COMPOSITIVO MANIGLIE ORIZZONTALI

Compositional example horizontal handles
Exemple de composition poignées horizontales
Ejemplo de composición tiradores horizontales
Kompositionsbeispiel horizontale Griffe

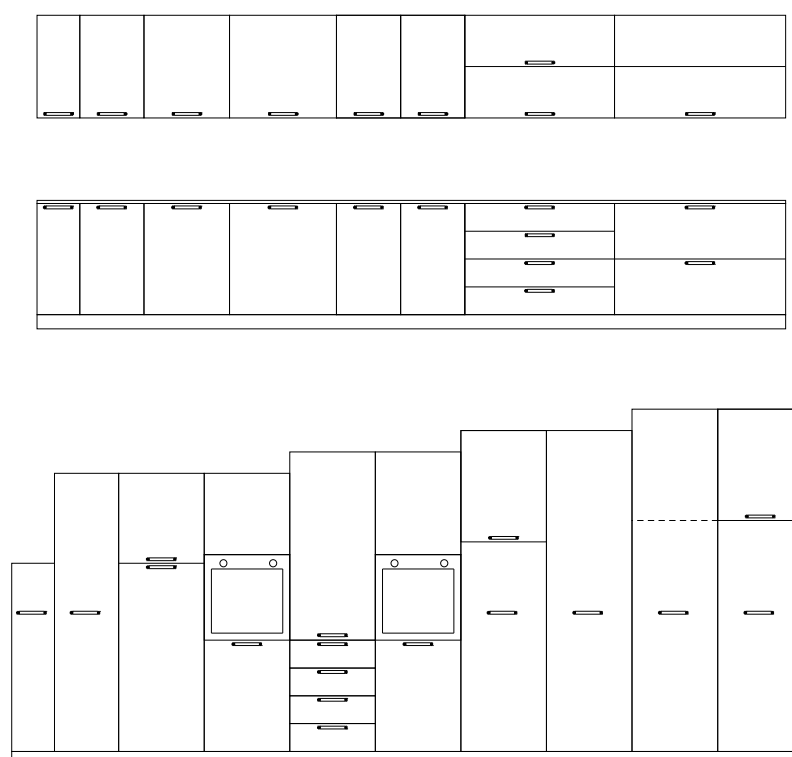

Basi con maniglia
Base units with handle

Basi con gola
Base units with groove

Colonne
Tall units

Pensili
Wall units

Elementi speciali
Special elements

Maniglie gole zoccoli
Handles grooves plinth

Illuminazione
Lighting

Accessori
Accessories

Componenti e meccanismi
Components e mechanism

MANIGLIA M04

M04 Handle
Poignée M04
Tirador M04
Griff M04

Maniglia M04 con supporto in zama - tubo metallo godronato

Handle M04 with zamak holder - knurled metal tube
Poignée M04 avec support en zamak - tube métallique moleté
Asa M04 con soporte de zamak - tubo metálico estriado
Griff M04 mit Zamakhalter - gerändeltes Metallrohr

FINITURE	L/W	CODICE	PUNTI
Nero opaco	129,6	KMAN0417AN	139

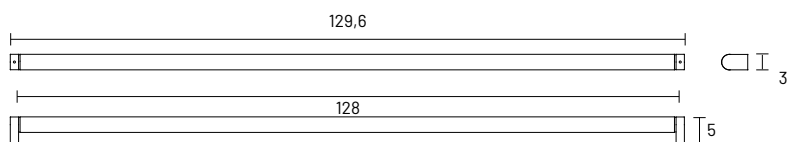
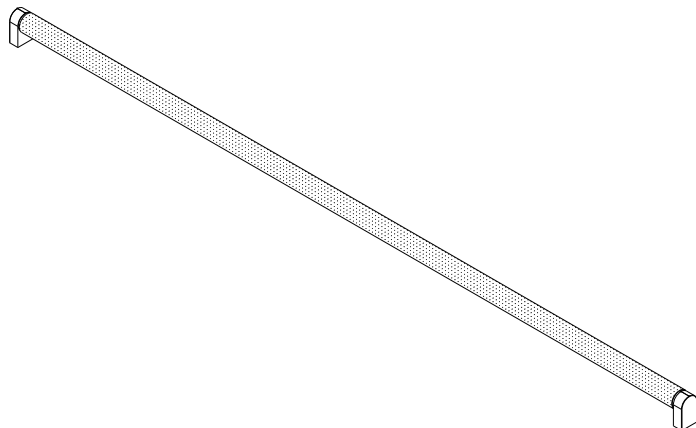

Interasse 64 cm

Wheelbase 64 cm
Entraxe 64 cm
Distancia entre ejes 64 cm
Raster 64 cm

POSIZIONAMENTI MANIGLIE

Handle placements
Positionnement des poignées
Posicionamiento tiradores
Griffe positionieren

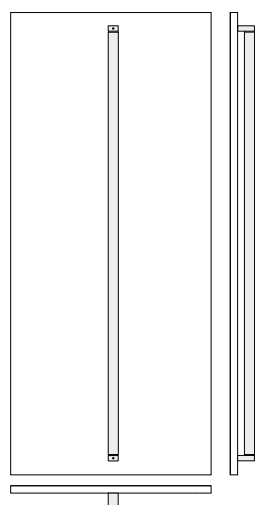

Posizionamento verticale

Vertical positioning
Positionnement vertical
Posicionamiento vertical
Vertikale Positionierung

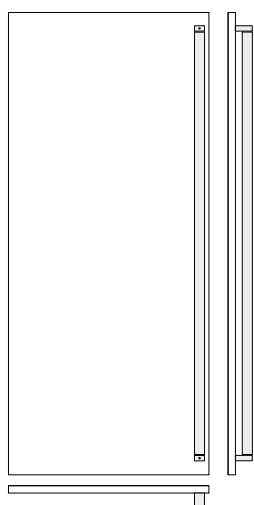

Posizionamento verticale laterale

Lateral vertical positioning
Positionnement latéral vertical
Posicionamiento vertical lateral
Vertikale seitliche Positionierung

MANIGLIA M04

M04 Handle
Poignée M04
Tirador M04
Griff M04

ESEMPIO COMPOSITIVO MANIGLIE VERTICALI

Composition example vertical handles
Exemple de composition poignées verticales
Ejemplo de composición tiradores verticales
Kompositionsbeispiel vertikale Griffe

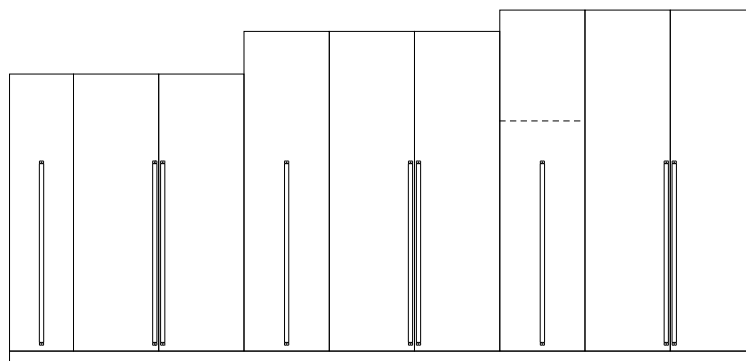

MANIGLIA INSIDE

INSIDE Handle
Poignée INSIDE
Tirador INSIDE
Griff INSIDE

Maniglia Inside in alluminio verniciato

Inside handle in painted aluminum
Poignée Inside en alu verni
Tirador INSIDE en aluminio barnizado
Griff INSIDE Aluminium lackiert

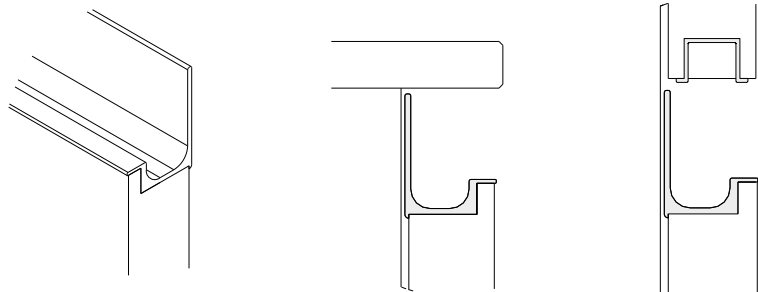

L/W	CODICE	PUNTI
14,7	KMAN1015	10
24,7	KMAN1025	18
29,7	KMAN1030	21
44,7	KMAN1045	32
59,7	KMAN1060	42
74,7	KMAN1075	53
89,7	KMAN1090	64
104,7	KMAN1105	74
119,7	KMAN1120	85

MANIGLIA INSIDE

INSIDE Handle
Poignée INSIDE
Tirador INSIDE
Griff INSIDE

ESEMPIO COMPOSITIVO

Compositional example
Exemple de composition
Ejemplo de composición
Beispiel für eine Komposition

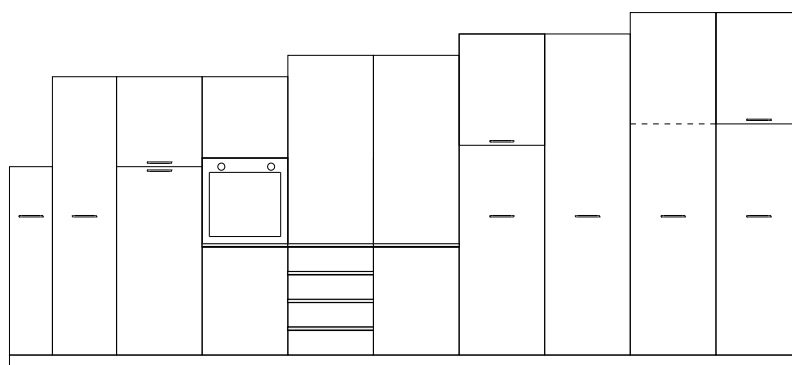
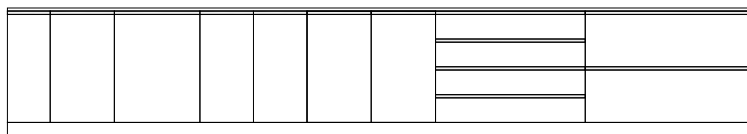

Basi con maniglia
Base units with handle

Basi con gola
Base units with groove

Colonne
Tall units

Pensili
Wall units

Elementi speciali
Special elements

Maniglie gole zoccoli
Handles grooves plinth

Illuminazione
Lighting

Accessori
Accessories

Componenti e meccanismi
Components e mechanism

FINITURE PRESE

Finishes taken
Finitions des prises électriques
Acabados tomas
Ausführungen der Steckdosen

Prese in alluminio integrate nell'anta e utilizzabili in abbinamento con gola piatta.

Aluminum grip built into the sash and can be used in conjunction with flat throat.
Prises en aluminium intégrées dans la porte et pouvant être utilisées en combinaison avec des rainures plates.
Enchufes de aluminio integrados en la puerta, se utilizan en combinación con uñeros planos.
In die Tür integrierte Aluminiumdosen, die in Kombination mit flachen mulde verwendet werden können.

FINITURE FINISHES FINITIONS ACABADOS AUSFÜHRUNG

- **ALLUMINIO | TEXTURED FINISH**
MU0 Cenere, MU1 Nero, MU2 Bianco
- **FENIX NTM® | FENIX NTM®**
FM0 Bianco Kos, FM1 Beige Arizona, FM2 Castoro Ottawa, FM3 Grigio Londra, FM4 Rosso Jaipur, FM5 Verde Comodoro, FM6 Nero Ingo
- **LACCATO OPACO | MATT LACQUER**
010 Bianco, 000 Panna, 001 Crema, 002 Grigio Perla, 003 Grigio Seta, 004 Corda, 005 Moka, 006 Blu Cobalto, 007 Grigio Aston, 008 Grigio Antracite, 009 Nero

PRESE

Grip
Prises
Tomas de corriente
Steckdosen

Profilo per pensile

Profile for wall unit
Profil pour module suspendu
Perfil para colgante
Profil für Hängeschrank

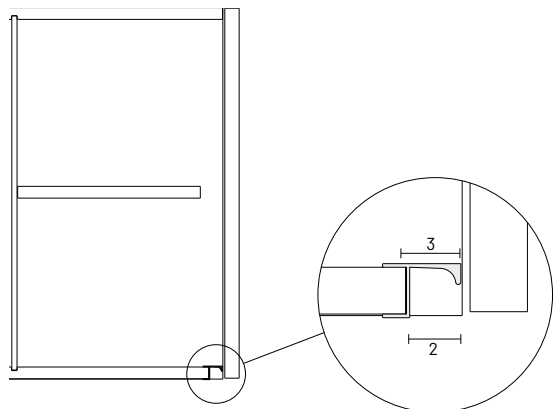

FINITURE	L/W	CODICE	PUNTI
Anodizzato nero	11,3	KPRP1011	14
	26,3	KPRP1026	16
	41,3	KPRP1041	19
	56,3	KPRP1056	21
	71,3	KPRP1071	23
	86,3	KPRP1086	25
	101,3	KPRP1101	27
	116,3	KPRP1116	29
	65	KPRP1031	29

PRESA "L"

"L" grip
Prise "L"
Toma "L"
L"-Steckdose

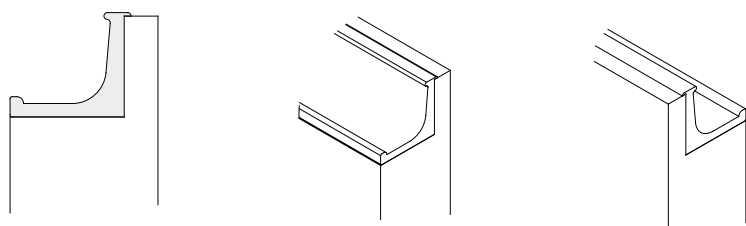

PRESA 30°

30° socket
Prise de 30
Toma de 30
30°-Steckdose

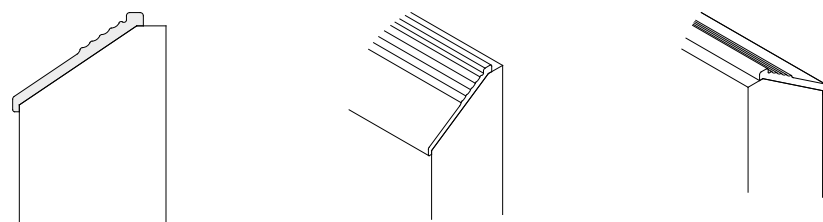

Basi con maniglia
Base units with handle

Basi con gola
Base units with groove

Colonne
Tall units

Pensili
Wall units

Elementi speciali
Special elements

Maniglie gole zoccoli
Handles grooves plinth

Illuminazione
Lighting

Accessori
Accessories

Componenti e meccanismi
Components e mechanism

PRESE

Grip
Prises
Tomas de corriente
Steckdosen

ESEMPIO COMPOSITIVO PRESE SU BASI

Compositional example taken on base units
Exemple de composition pris sur les bases
Ejemplo de composición tomas en bases
Beispiel für die Zusammensetzung von Griffen
Unterschranke

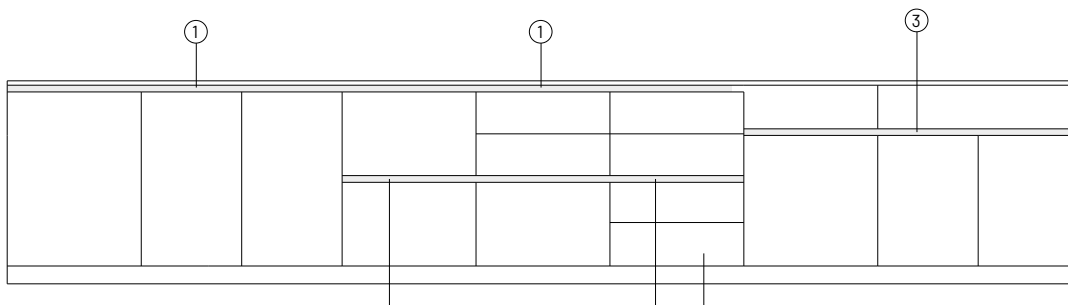

PRESA "L"

"L" grip
Prise "L"
Toma "L"
L"-Steckdose

1

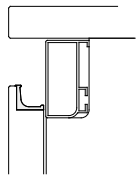

2

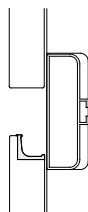

3

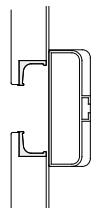

4

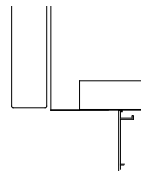

PRESA 30°

30° socket
Prise de 30
Toma de 30
30°-Steckdose

1

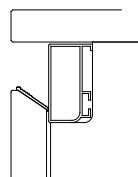

2

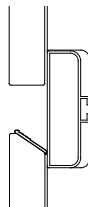

3

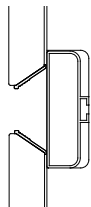

4

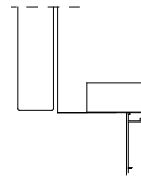

PRESE

Grip
Prises
Tomas de corriente
Steckdosen

ESEMPIO COMPOSITIVO PRESE SU COLONNE

Compositional example taken on tall units
Exemple de composition prise sur des colonnes
Ejemplo de composición tomas en columnas
Kompositionsbeispiel Griffe auf Hochschränke

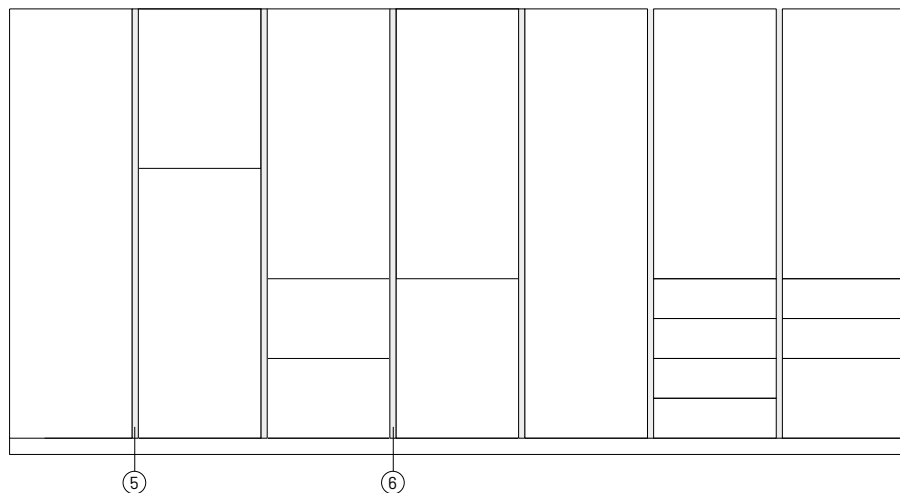

PRESA "L"

"L" grip
Prise "L"
Toma "L"
L"-Steckdose

5

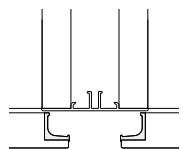

6

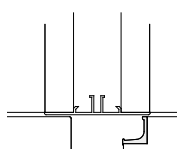

PRESA 30°

30° socket
Prise de 30°
Toma de 30°
30°-Steckdose

5

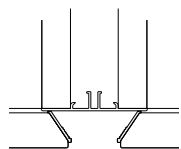

6

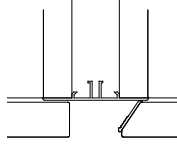

Basi con maniglia
Base units with handle

Basi con gola
Base units with groove

Colonne
Tall units

Pensili
Wall units

Elementi speciali
Special elements

Maniglie gole zoccoli
Handles grooves plinth

Illuminazione
Lighting

Accessori
Accessories

Componenti e meccanismi
Components e mechanism

FINITURE GOLE

Groove finishes
Finitions de la rainure
Acabados uñeros
Ausführung Griffleiste

Gole piatte o invacate in alluminio.

Flat or invacate aluminum grooves.
Rainures plates ou encastrées en alu
Uñeros de aluminio planas o invacadas.
Griffleiste oder eingebaute Griimulde Aluminium.

FINITURE FINISHES FINITIONS ACABADOS AUSFÜHRUNG	GOLA INCAVATA CURVED GROOVE RAINURE ENCASTRÉE UÑERO HUECO GRIFFMULDE	GOLA PIATTA FLAT GROOVE RAINURE PLATE UÑERO PLANO GRIFFLEISTE
<ul style="list-style-type: none"> ALLUMINIO TEXTURED FINISH MU0 Cenere, MU1 Nero, MU2 Bianco 	A	A
<ul style="list-style-type: none"> FENIX NTM® FENIX NTM® FM0 Bianco Kos, FM1 Beige Arizona, FM2 Castoro Ottawa, FM3 Grigio Londra, FM4 Rosso Jaipur, FM5 Verde Comodoro, FM6 Nero Ingo 	B	B
<ul style="list-style-type: none"> LACCATO OPACO MATT LACQUER O10 Bianco, O00 Panna, O01 Crema, O02 Grigio Perla, O03 Grigio Seta, O04 Corda, O05 Moka, O06 Blu Cobalto, O07 Grigio Aston, O08 Grigio Antracite, O09 Nero 	B	B
<ul style="list-style-type: none"> LACCATO LUCIDO GLOSSY LACQUERED L10Bianco, L00 Panna, L01 Crema, L02 Grigio Perla, L03 Grigio Seta, L04 Corda, L05 Moka, L06 Blu Cobalto, L07 Grigio Aston, L08 Grigio Antracite, L09 Nero 	-	C
<ul style="list-style-type: none"> ESSENZA 1 WOOD 1 ER0 Rovere Visone, ER1 Rovere Castoro, ER2 Rovere Carbone, ER3 Rovere Cenere 	-	C
<ul style="list-style-type: none"> ESSENZA 2 WOOD 2 EE0 Noce Canaletto, EE1 Rovere Termotrattato 	-	D
<ul style="list-style-type: none"> LACCATO METALLO LACQUERED METAL L00 Ottone, L01 Acciaio, L02 Bronzo LS0 Oro, LS1 Ottone, LS2 Bronzo scuro, LS3 Titanio LA0 Ottone, LA1 Bronzo scuro, LA2 Silicio 	-	D

GOLA INCAVATA

Curved groove
Rainure plate
Uñero plano
Griffleiste

ORIZZONTALE

Horizontal
Horizontal
Horizontal
Horizontal

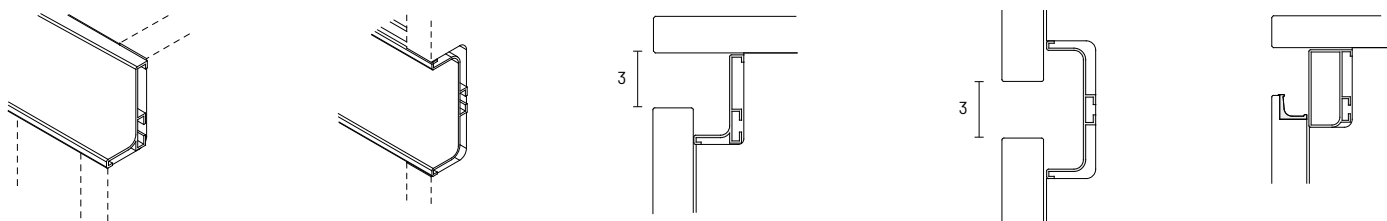

VERTICALE

Vertical
Vertical
Vertical
Vertikal

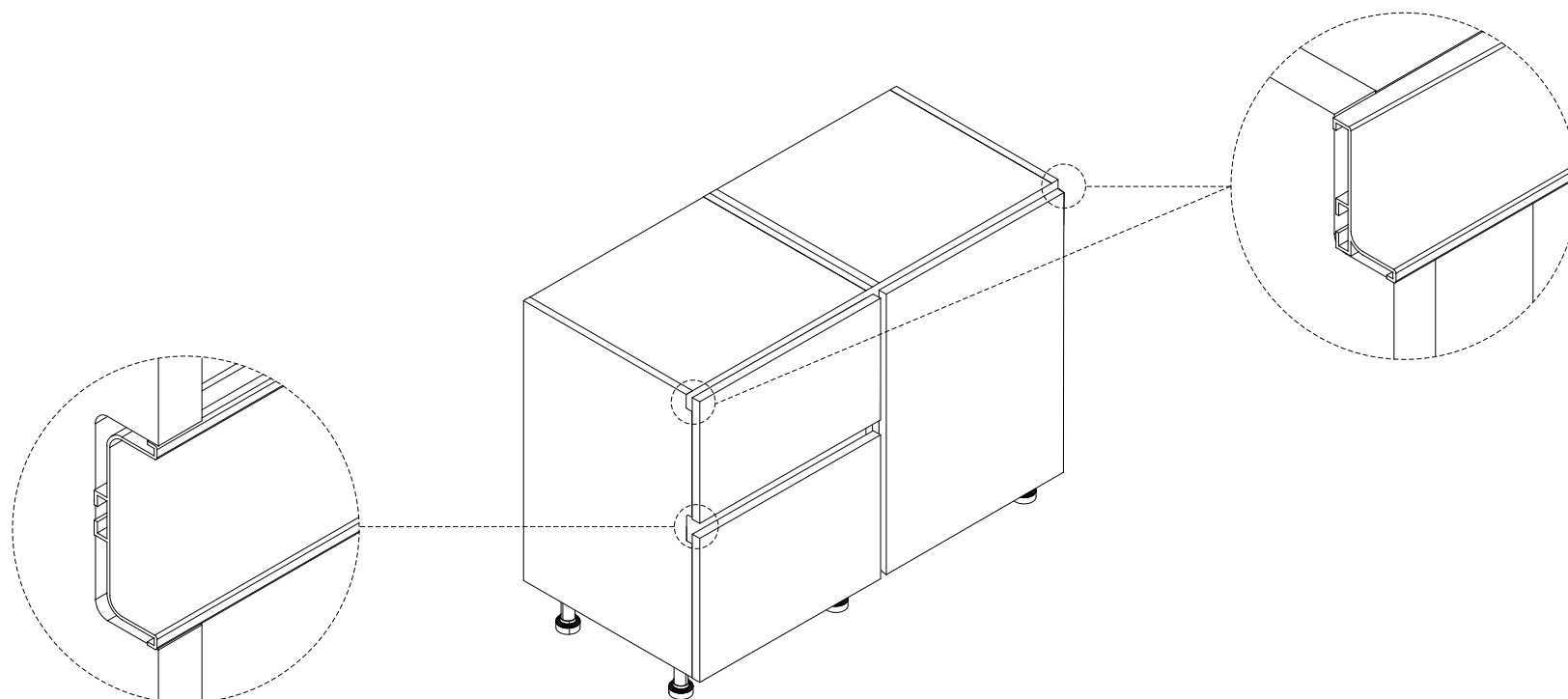
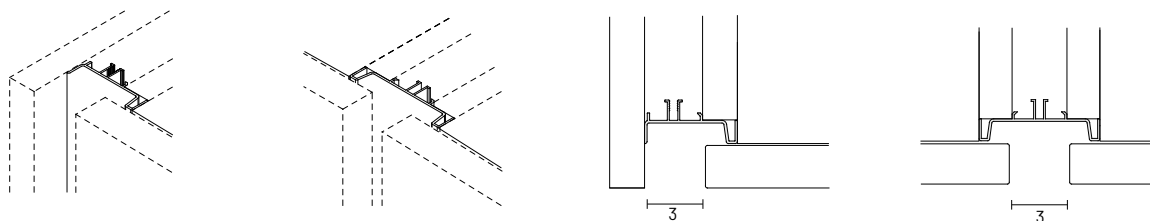

Basi con maniglia
Base units with handle

Basi con gola
Base units with groove

Colonne
Tall units

Pensili
Wall units

Elementi speciali
Special elements

Maniglie gole zoccoli
Handles grooves plinth

Illuminazione
Lighting

Accessori
Accessories

Componenti e meccanismi
Components e mechanism

GOLA INCAVATA

Curved groove
Rainure encastrée
Uñero hueco
Griffmulde

Gola incavata sottotop

Undertop curved groove
Rainure encastrée sous le plateau
Uñero hueco bajo encimera
untereingebaute Griffmulde

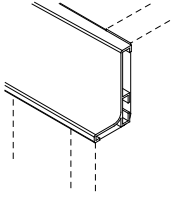

	CODICE	A	B	C	D
al ml	KGIS149	19	29	-	-

Gola incavata intermedia

Intermediate curved groove
Rainure intermédiaire encastrée
Uñero hueco intermedio
Eingebaute Griffmulde

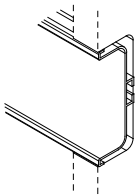

	CODICE	A	B	C	D
al ml	KGII173	24	34	-	-

GOLA INCAVATA

Curved groove
Rainure encastrée
Uñero hueco
Griffmulde

Tappo di chiusura gola incavata sottotop

End cap for curved throat undertop
Capuchon de gorge encastré sous le sommet
Tapón para uñero empotrado bajo encimera
Endkappe eingelassene Mulde

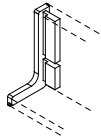

CODICE	A	B	C	D
--------	---	---	---	---

KGITSV49D	21	28	-	-
-----------	----	----	---	---

KGITSV49S	21	28	-	-
-----------	----	----	---	---

Basi con maniglia
Base units with handle

Basi con gola
Base units with groove

Colonne
Tall units

Pensili
Wall units

Elementi speciali
Special elements

Maniglie gole zoccoli
Handles grooves plinth

Illuminazione
Lighting

Accessori
Accessories

Componenti e meccanismi
Components e mechanism

Tappo di chiusura gola incavata sottotop

End cap for curved throat undertop
Capuchon de gorge encastré sous le sommet
Tapón para uñero empotrado bajo encimera
Endkappe eingelassene Mulde

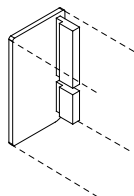

CODICE	A	B	C	D
--------	---	---	---	---

KGITSB49D	21	28	-	-
-----------	----	----	---	---

KGITSB49S	21	28	-	-
-----------	----	----	---	---

Tappo di chiusura gola incavata angolo interno

End cap for curved groove inside corner
Embout à rainure encastrée coin intérieur
Tapón para uñero empotrado ángulo interno
Endkappe mit vertiefter Mulde an der Innenseite der Ecke

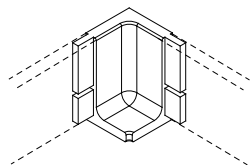

CODICE	A	B	C	D
--------	---	---	---	---

KGIAI49	38	45	-	-
---------	----	----	---	---

GOLA INCAVATA

Curved groove
Rainure encastrée
Uñero hueco
Griffmulde

Tappo di chiusura gola incavata angolo esterno

End cap for curved groove outer corner
Rainure encastrée capuchon d'extrémité coin extérieur
Tapón para uñero empotrado ángulo externo
Vertiefte Nut Endkappe Außenecke

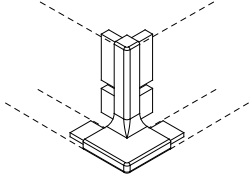

CODICE	A	B	C	D
KGIAE49	54	61	-	-

Tappo di chiusura gola incavata intermedio esterno

End cap for intermediate outside curved groove
Rainure encastrée Capuchon d'extrémité Intermédiaire à l'extérieur
Tapón para uñero empotrado intermedio externo
Endkappe mit vertiefter Mulde zwischen den Außenseiten

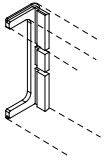

CODICE	A	B	C	D
KGITIV73	21	28	-	-

Tappo di chiusura gola incavata intermedio filo

End cap for flush intermediate curved groove
Capuchon d'extrémité à rainure intermédiaire affleurante
Tapón para uñero empotrado intermedio filo
Bündige Zwischemulde-Endkappe

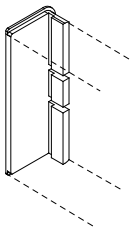

CODICE	A	B	C	D
KGITIB73	21	28	-	-

GOLA INCAVATA

Curved groove
Rainure encastrée
Uñero hueco
Griffmulde

Gola incavata verticale intermedia

Intermediate vertical curved groove
Rainure intermédiaire encastrée verticale
Uñero hueco intermedio vertical
Zwischenliegende vertikale Griffmulde

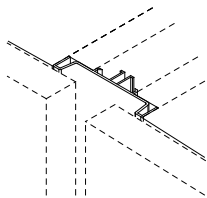

H/H	CODICE	A	B	C	D
132	KGIVI132	40	54	-	-
195	KGIVI195	59	79	-	-
210	KGIVI210	63	85	-	-
225	KGIVI225	68	91	-	-
240	KGIVI240	72	97	-	-
al ml	KGIVI1400	30	41	-	-

Gola incavata verticale terminale

Vertical curved end groove
Rainure encastrée verticale terminale
Uñero hueco intermedio terminal
Vertikale vertiefte Griffmulde

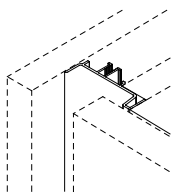

H/H	CODICE	A	B	C	D
132	KGIVT132	35	48	-	-
195	KGIVT195	51	72	-	-
210	KGIVT210	55	77	-	-
225	KGIVT225	59	83	-	-
240	KGIVT240	63	88	-	-
al ml	KGIVT1400	26	37	-	-

Basi con maniglia
Base units with handle

Basi con gola
Base units with groove

Colonne
Tall units

Pensili
Wall units

Elementi speciali
Special elements

Maniglie gole zoccoli
Handles grooves plinth

Illuminazione
Lighting

Accessori
Accessories

Componenti e meccanismi
Components e mechanism

GOLA PIATTA

Flat groove
Rainure plate
Uñero plano
Griffleiste

ORIZZONTALE

Horizontal
Horizontal
Horizontal
Horizontal

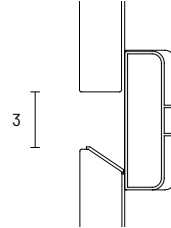
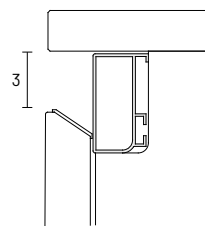
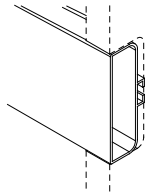
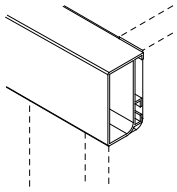

VERTICALE

Vertical
Vertical
Vertical
Vertikal

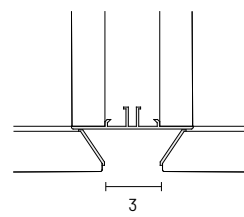
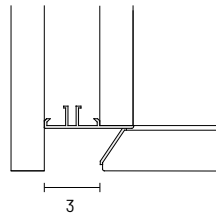
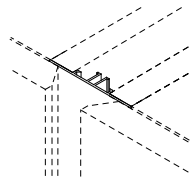
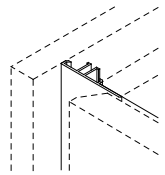

GOLA PIATTA

Flat groove
Rainure plate
Uñero plano
Griffleiste

Gola piatta sottotop

Undertop flat groove
Rainure plate sous le plateau
Uñero plano bajo encimera
Untergebaute Griffleiste

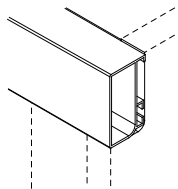

	CODICE	A	B	C	D
al ml	KGPS149	29	40	49	145

Gola piatta intermedia

Intermediate flat groove
Rainure plate intermédiaire
Uñero plano intermedio
Mittlere Griffleiste

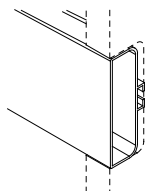

	CODICE	A	B	C	D
al ml	KGPI173	33	44	53	149

Basi con maniglia
Base units with handle

Basi con gola
Base units with groove

Colonne
Tall units

Pensili
Wall units

Elementi speciali
Special elements

Maniglie gole zoccoli
Handles grooves plinth

Illuminazione
Lighting

Accessori
Accessories

Componenti e meccanismi
Components e mechanism

GOLA PIATTA

Flat groove
Rainure plate
Uñero plano
Griffleiste

Tappo di chiusura gola piatta sottotop

Under-top flat throat closure cap
Capuchon de fermeture à gorge plate sous le capuchon
Tapón para uñero plano bajo encimera
Endkappe fuer flachem Halsverschluss

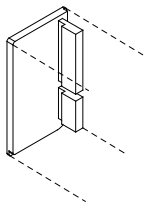

CODICE	A	B	C	D
KGPTSB49D	21	28	38	44
KGPTSB49S	21	28	38	44

Tappo di chiusura gola piatta sottotop filo

Undertop wire flat throat end cap
Capuchon de fermeture à gorge affleurante
Tapón para uñero plano bajo encimera filo
Verschlusskappe mit bündigem Mulde

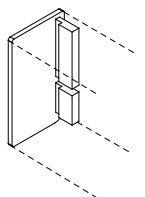

CODICE	A	B	C	D
KGPTSV49D	21	28	38	44
KGPTSV49S	21	28	38	44

Tappo di chiusura gola piatta intermedio esterno

External intermediate flat throat end cap
Embout intermédiaire externe à gorge plate
Tapón para uñero plano intermedio externo
Endkappe Externe Zwischenkappe mit flachem Mulde

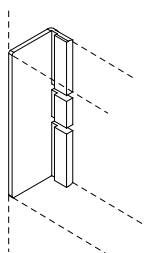

CODICE	A	B	C	D
KGPTIB73	21	28	38	44

GOLA PIATTA

Flat groove
Rainure plate
Uñero plano
Griffleiste

Tappo di chiusura gola piatta intermedio filo

Flat groove intermediate wire end cap
Embout de fil intermédiaire à rainure plate
Tapón para uñero plano intermedio filo
Flachmulde Endkappe

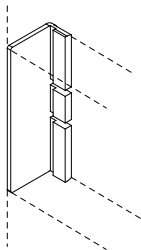

CODICE	A	B	C	D
KGPTIV73	21	28	38	44

Tappo di chiusura gola piatta angolo interno

Flat groove end cap inside corner
Embout à rainure plate coin intérieur
Tapón para uñero plano ángulo interno
Flachmulde-Endkappe Innenecke

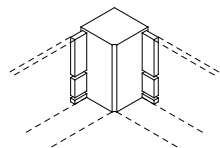

CODICE	A	B	C	D
KGPAI49	38	45	52	60

Tappo di chiusura gola incavata angolo esterno

End cap for curved groove outer corner
Rainure encastrée capuchon d'extrémité coin extérieur
Tapón para uñero empotrado ángulo externo
Vertiefte Nut Endkappe Außenecke

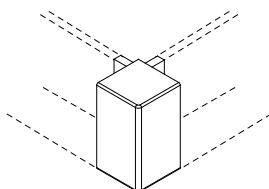

CODICE	A	B	C	D
KGPAE49	42	53	60	65

Basi con maniglia
Base units with handle

Basi con gola
Base units with groove

Colonne
Tall units

Pensili
Wall units

Elementi speciali
Special elements

Maniglie gole zoccoli
Handles grooves plinth

Illuminazione
Lighting

Accessori
Accessories

Componenti e meccanismi
Components e mechanism

GOLA PIATTA

Flat groove
Rainure plate
Uñero plano
Griffleiste

Gola piatta verticale intermedia

Flat vertical intermediate groove
Rainure intermédiaire plate verticale
Uñero plano intermedi vertical
Vertikale Zwischen Griffleiste

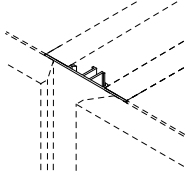

H/H	CODICE	A	B	C	D
132	KGPVI132	33	47	66	193
195	KGPVI195	49	69	98	285
210	KGPVI210	53	75	105	307
225	KGPVI225	56	80	113	329
240	KGPVI240	60	85	120	351
al ml	KGPVI1400	25	36	50	146

Gola piatta verticale terminale

Vertical flat end groove
Rainureplate verticale terminale
Uñero plano intermedio terminal
Abschluss Griffleiste

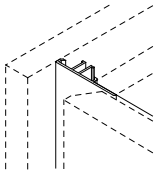

H/H	CODICE	A	B	C	D
132	KGPVT132	28	42	58	185
195	KGPVT195	41	62	86	273
210	KGPVT210	44	67	93	294
225	KGPVT225	48	71	99	315
240	KGPVT240	51	76	106	336
al ml	KGPVT1400	21	32	44	140

FINITURE ZOCCOLI

Plinth finishes
Finitions des plinthes
Acabados zócalos
Ausführungen des Sockels

Zoccolo in alluminio posizionato rientrando di 5,8 cm rispetto alla base e fissato mediante aggancio magnetico.

Aluminum plinth positioned recessed 5.8 cm from the base and secured by magnetic attachment.
Plinthe aluminium positionné à 5,8 cm en retrait de la base et fixé à l'aide d'une fermeture magnétique.
Zócalo de aluminio colocado 5,8 cm atrás de la base y fijado mediante cierre magnético.
Aluminiumsockel, der 5,8 cm vom Sockel zurückgesetzt ist und mit einem Magnetverschluss gesichert wird.

FINITURE FINISHES FINITIONS ACABADOS AUSFÜHRUNG	FASCIA DI PREZZO PRICE RANGE CATÉGORIE DE PRIX CATEGORÍA DE PRECIO PREISKLASSE
<ul style="list-style-type: none"> PVC ALLUMINIO PVC ALUMINUM PVC Alluminio 	A
<ul style="list-style-type: none"> ALLUMINIO TEXTURED FINISH MU0 Cenere, MU1 Nero, MU2 Bianco 	B
<ul style="list-style-type: none"> FENIX NTM® FENIX NTM® FM0 Bianco Kos, FM1 Beige Arizona, FM2 Castoro Ottawa, FM3 Grigio Londra, FM4 Rosso Jaipur, FM5 Verde Comodoro, FM6 Nero Ingo 	C
<ul style="list-style-type: none"> LACCATO OPACO MATT LACQUER 010 Bianco, 000 Panna, 001 Crema, 002 Grigio Perla, 003 Grigio Seta, 004 Corda, 005 Moka, 006 Blu Cobalto, 007 Grigio Aston, 008 Grigio Antracite, 009 Nero 	C
<ul style="list-style-type: none"> LACCATO LUCIDO GLOSSY LACQUERED L10Bianco, L00 Panna, L01 Crema, L02 Grigio Perla, L03 Grigio Seta, L04 Corda, L05 Moka, L06 Blu Cobalto, L07 Grigio Aston, L08 Grigio Antracite, L09 Nero 	D
<ul style="list-style-type: none"> ESSENZA 1 WOOD 1 ER0 Rovere Visone, ER1 Rovere Castoro, ER2 Rovere Carbone, ER3 Rovere Cenere 	D
<ul style="list-style-type: none"> ESSENZA 2 WOOD 2 EE0 Noce Canaletto, EE1 Rovere Termotrattato 	E
<ul style="list-style-type: none"> LACCATO METALLO LACQUERED METAL L00 Ottone, L01 Acciaio, L02 Bronzo LS0 Oro, LS1 Ottone, LS2 Bronzo scuro, LS3 Titanio LA0 Ottone, LA1 Bronzo scuro, LA2 Silicio 	E

Basi con maniglia
Base units with handle

Basi con gola
Base units with groove

Colonne
Tall units

Pensili
Wall units

Elementi speciali
Special elements

Maniglie gole zoccoli
Handles grooves plinth

Illuminazione
Lighting

Accessori
Accessories

Componenti e meccanismi
Components e mechanism

ZOCCOLI

Plinth
Plinthe
Zócalos
Sockel

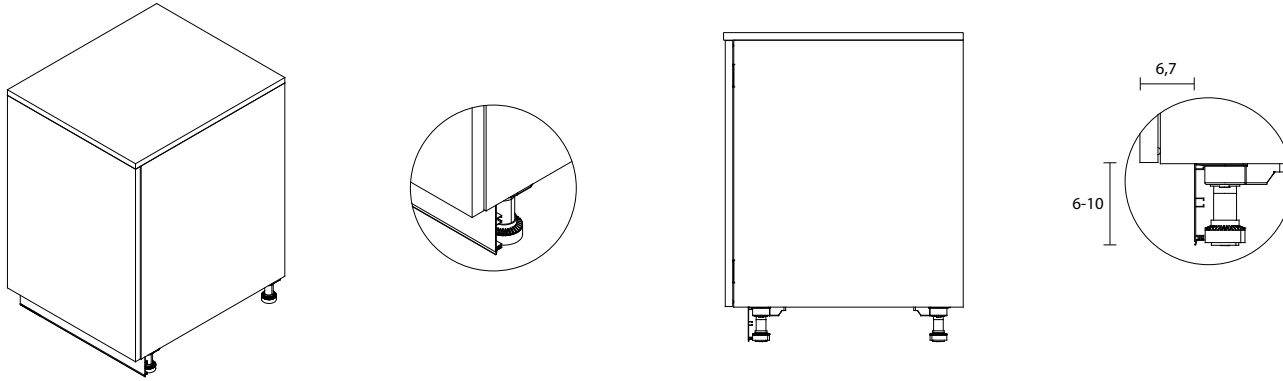

Zoccolo PVC H 10 in resina artificiale completo di guarnizione, rivestito in foglia di alluminio

PVC plinth H 10 in artificial resin complete with gasket, covered in aluminium foil
Plinthe en PVC H 10 en résine artificielle avec joint d'étanchéité, recouvert d'une feuille d'aluminium
Zócalo de PVC H 10 de resina artificial completo con sello, cubierto de papel de aluminio
PVC-Sockel H 10 aus Kunstharz, komplett mit Dichtung, Mit Aluminiumfolie überzogen



Zoccolo alluminio H 6/10 in alluminio estruso anodizzato, verniciato, laccato o placcato con tranciato verniciato completo di guarnizione

Aluminium plinth H 6/10 in anodised, painted, lacquered or veneered extruded aluminium complete with seal
Plinthe en aluminium H 6/10 en aluminium extrudé anodisé, peint, laqué ou plaqué, complet avec joint
Zócalo H 6/10 de aluminio extruido anodizado, barnizado, lacado o chapado, completo con sello
Aluminiumsockel H 6/10 aus eloxiertem, lackiertem oder furniertem, stranggepresstem Aluminium, komplett mit Dichtung

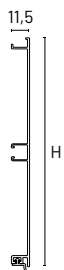

ZOCCOLI

Plinth
Plinthe
Zócalos
Sockel

Zoccolo frontale

Front plinth
Plinthe frontale
Zócalo frontal
Vorderer Sockel

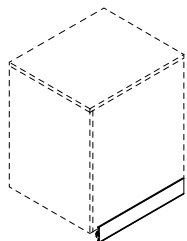

H/H	CODICE	A	B	C	D	E
6	KZC0106	-	24	35	50	147
10	KZC0110	7	30	41	56	153

Zoccolo laterale

Side plinth
Plinthe latérale
Zócalo lateral
Seitlicher Sockel

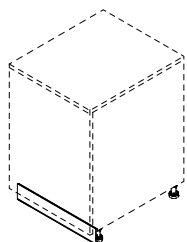

H/H	CODICE	A	B	C	D	E
6	KZC0206	-	24	35	50	147
10	KZC0210	7	30	41	56	153

Basi con maniglia
Base units with handle

Basi con gola
Base units with groove

Colonne
Tall units

Pensili
Wall units

Elementi speciali
Special elements

Maniglie gole zoccoli
Handles grooves plinth

Illuminazione
Lighting

Accessori
Accessories

Componenti e meccanismi
Components e mechanism

ZOCCOLI

Plinth
Plinthe
Zócalos
Socket

Angolare terminale 90°

End angle 90°
Angle terminal 90°
Ángulo terminal 90°
Endwinkel 90°

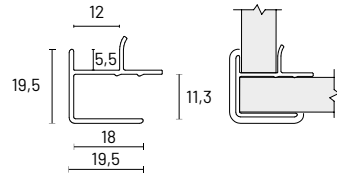

H/H	CODICE	A	B	C	D	E
6	KZCA106	-	5	13	27	51
10	KZCA110	5	6	13	27	52

Angolare regolabile 90°-135°

Adjustable angle 90°-135°
Angle réglable 90°-135°
Ángulo ajustable 90°-135°
Einstellbarer Winkel 90°-135°

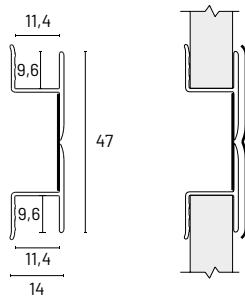

H/H	CODICE	A	B	C	D	E
6	KZCA206	-	7	17	33	56
10	KZCA210	7	8	18	34	57

Giunzione lineare

Linear joint
Articulation linéaire
Unión lineal
Lineares Verbindung

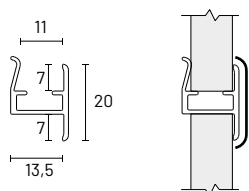

H/H	CODICE	A	B	C	D	E
6	KZCG106	-	5	13	27	51
10	KZCG110	5	6	13	27	52

ILLUMINAZIONE

Lighting
Eclairage
Iluminación
Beleuchtung

LUCE LED AD INCASSO Recessed led light Eclairage LED encastré Luz led empotrada LED-Einbauleuchte	P. 292
<ul style="list-style-type: none">• LUCE LED ESTERNA AD INCASSO Outdoor LED recessed light Eclairage LED extérieur encastré Luz led externa empotrada LED-Einbauleuchte für den Außenbereich• LUCE LED INTERNA AD INCASSO Interior LED recessed light Eclairage LED intérieur encastré Luz led empotrada interior LED-Einbauleuchte innen	P. 293 P. 294
PROFILO LED LED profile Profil LED Perfil LED LED-Profil	P. 296
<ul style="list-style-type: none">• PROFILO LED ESTERNO SCOCCA LED outer shell profile Profil LED extérieure à la structure Perfil LED exterior de la estructura LED-Außenhautprofil• PROFILO LED INTERNO SCOCCA LED profile inside bodywork Profil LED à l'intérieur de la structure Perfil LED interior de la estructura Innen LED-Profil	P.296 P. 297
SCHIENALE LUMINOSO Luminous backrest Dos lumineux Trasera iluminada Beleuchtete Rückwand	P. 299
ILLUMINAZIONE INTERNO CASSETTI Internal drawer lighting Eclairage intérieur des tiroirs Iluminación interior de cajones Innenbeleuchtung der Schubladen	P. 300
SISTEMI DI ALIMENTAZIONE Power systems Systèmes d'alimentation Sistemas de alimentación Fütterungssysteme	P. 301

Basi con maniglia
Base units with handle

Basi con gola
Base units with groove

Colonne
Tall units

Pensili
Wall units

Elementi speciali
Special elements

Maniglie gole zoccoli
Handles grooves plinth

illuminazione
Lighting

Accessori
Accessories

Componenti e meccanismi
Components e mechanism

LUCE LED AD INCASSO

Recessed led light
Eclairage LED encastré
Luz led empotrada
LED-Einbauleuchte

DESCRIZIONE Estruso di policarbonato opalino incassato in fresata. Dispositivo LED Dual Color (3000 °K - 4000 °K) alimentato a 24V, consumo 14,4 W/ml

APPLICAZIONE Nel lato inferiore interno di pensili, vetrine e moduli a giorno. Nel lato inferiore esterno di pensili o mensole. Nel lato superiore esterno o nel lato esterno di fianchi di pensili, colonne, basi con anta battente, vetrine e moduli a giorno. Per l'applicazione su altre tipologie consigliamo di contattare il Customer Service.

COLLEGAMENTO Nel caso di LED interno l'accensione avviene mediante sensore laser (installato nella schiena della scocca) che accende l'impianto all'apertura dell'anta. In questo caso la dimmerazione non è possibile e l'eventuale cambio colore deve essere fatto al momento dell'installazione. L'accensione può avvenire anche mediante telecomando grazie all'applicazione di un ricevente su ogni alimentatore. Un singolo telecomando può comandare più alimentatori contemporaneamente. Un singolo ricevente può essere gestito da più telecomandi.

Nel caso di LED esterno l'accensione avviene mediante sensore touch (integrato nella lampada) che garantisce inoltre dimmerazione e cambio colore. Nel caso di collegamento all'impianto domestico (interruttore a cura del cliente) la dimmerazione non è possibile e l'eventuale cambio colore deve essere fatto al momento dell'installazione.

DESCRIPTION Extruded opal polycarbonate embedded in milled. Dual Colour LED device (3000 °K - 4000 °K) powered at 24V, consumption 14.4 W/ml

APPLICATION In the inside underside of wall units, display cases and open modules. In the outside bottom side of wall units or shelves. In the upper outer side or in the outer side of sides of wall units, columns, base units with hinged doors, display cases and open modules. For application on other types, we recommend contacting Customer Service.

LINK In the case of internal LEDs, the lighting is done by means of a laser sensor (installed in the back of the body) that turns on the system when the sash is opened. In this case dimming is not possible and any colour change must be done at the time of installation. Turning on can also be done by remote control thanks to the application of a receiver on each power supply. A single remote control can control several feeders at the same time. A single receiver can be operated by multiple remote controls.

In the case of external LEDs, lighting is done by touch sensor (built into the lamp), which also ensures dimming and colour change. In the case of connection to the domestic system (switch by the customer) dimming is not possible and any colour change must be done at the time of installation.

DESCRIPTION Polycarbonate opale extrudé encastré dans le fraisage. Luminaire LED bicolore (3000 °K - 4000 °K) alimenté en 24 V, consommation 14,4 W/ml.

APPLICATION Dans la partie inférieure intérieure des meubles hauts, des vitrines et des modules ouverts. Dans la partie inférieure extérieure des éléments muraux ou des étagères. Dans la partie supérieure extérieure ou dans la partie extérieure des côtés des meubles hauts, des meubles hauts, des meubles bas avec porte battante, des vitrines et des modules ouverts. Pour l'application sur d'autres types, veuillez contacter le service clientèle.

CONNEXION Dans le cas des LED internes, l'éclairage se fait au moyen d'un capteur laser (installé à l'arrière de la carrosserie) qui enclenche le système à l'ouverture de la porte. Dans ce cas, la gradation n'est pas possible et tout changement de couleur doit être effectué au moment de l'installation. La commutation peut également se faire par télécommande grâce à l'application d'un récepteur sur chaque ballast. Une seule télécommande peut contrôler plusieurs alimentations simultanément. Un seul récepteur peut être piloté par plusieurs télécommandes.

Dans le cas des LED externes, l'allumage se fait au moyen d'un capteur tactile (intégré dans la lampe) qui assure également la gradation et le changement de couleur. Dans le cas d'un raccordement à l'installation domestique (interrupteur par le client), la gradation n'est pas possible et tout changement de couleur doit être effectué au moment de l'installation.

DESCRIPCIÓN Policarbonato opal extruido empotrado en fresado. Luminaria LED bicolor (3000 °K - 4000 °K) alimentada a 24 V, consumo 14,4 W/ml.

APLICACIÓN En la parte interior interna de colgantes, vitrinas y módulos abiertos. En la parte inferior externa de colgantes o baldas. En la parte superior externa o bien externa de laterales de colgantes, columnas, bases puertas batientes, vitrinas y módulos abiertos. Para la aplicación en otros artículo rogamos se pongan en contacto con nuestras oficinas de venta.

ENLACE En el caso de los LED internos, el encendido se realiza mediante un sensor láser (instalado en la trasera de la estructura) que acciona el sistema cuando se abre la puerta. En este caso, la regulación no es posible y cualquier cambio de color debe realizarse en el momento de la instalación. El encendido puede efectuarse también con control remoto gracias a la aplicación de un receptor en cada alimentador. Un único mando a distancia puede controlar varios alimentadores simultáneamente. Un solo receptor puede ser accionado por varios mandos a distancia.

En el caso de los LED externos, el encendido se realiza mediante un sensor touch (integrado en la lámpara) que garantiza también la regulación y el cambio de color. En el caso de conexión a la red eléctrica de la habitación (interruptor a cargo del cliente) la regulación no es posible y cualquier cambio de color debe realizarse en el momento de la instalación.

BESCHREIBUNG Extrudierte Opal Polycarbonat in Fräsen vertieft. Dual Colour LED-Leuchte (3000 °K - 4000 °K) mit 24 V betrieben, Verbrauch 14,4 W/ml.

ANMELDUNG In der inneren Unterseite von Oberschränken, Vitrinen und offenen Modulen. In der äußeren Unterseite von Oberschränken oder Regalen. In der oberen Außenseite oder in der Außenseite der Seiten von Hängeschränken, Hochschränken, Unterschränken mit Drehtür, Vitrinen und offenen Modulen. Für die Anwendung bei anderen Typen wenden Sie sich bitte an den Kundendienst.

VERBINDUNG Bei internen LEDs erfolgt die Beleuchtung über einen Bewegungssensor, der das System beim Öffnen der Tür einschaltet. In diesem Fall ist ein Dimmen nicht möglich und jede Farbänderung muss zum Zeitpunkt der Installation vorgenommen werden. Die Schaltung kann auch über eine Fernbedienung erfolgen, da an jedem Vorschaltgerät ein Empfänger angebracht ist. Mit einer einzigen Fernbedienung können mehrere Vorschaltgeräte gleichzeitig gesteuert werden. Ein einziger Empfänger kann von mehreren Fernbedienungen bedient werden.

Bei externen LEDs erfolgt die Zündung über einen Berührungssensor (in der Lampe integriert), der auch das Dimmen und den Farbwechsel gewährleistet. Bei Anschluss an die Hausinstallation (bauseitiger Schalter) ist ein Dimmen nicht möglich und ein Farbwechsel muss bei der Installation vorgenommen werden.

LUCE LED AD INCASSO

Recessed led light
Eclairage LED encastré
Luz led empotrada
LED-Einbauleuchte

LED esterno per pensili e mensole

External LED for wall units and shelves
LED externe pour modules suspendus et étagères
LED exterior para colgantes y baldas
Externe LED für Hängeschränke und Regale

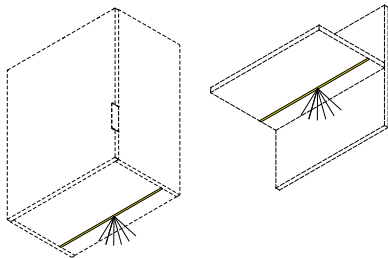

Led Dual Color (3000 - 4000 K) non dimmerabile
Dual Colour Led (3000 - 4000 K) not dimmable
LED Dual Color(3000 - 4000 K) non graduabile
LED bicolor (3000 - 4000 K) no regulable
Dual Colour LED (3000 - 4000 K) nicht dimmbar

L/W	WATT	CODICE	PUNTI
40,5	6	KILP1040	48
41,3	6	KILP1041	49
55,5	8	KILP1055	55
56,3	8	KILP1056	58
63,2	9	KILP1063	59
70,5	11	KILP1070	62
71,3	11	KILP1071	62
85,5	13	KILP1085	69
86,3	13	KILP1086	69
91,3	14	KILP1091	71
100,5	15	KILP1100	76
101,3	15	KILP1101	76
115,5	17	KILP1115	82
116,3	17	KILP1116	83
al ml	14	KILP2000	84

Selezionare l'alimentatore adatto a pag. 357

Select the appropriate power supply on p.357 | Sélectionner le bloc d'alimentation approprié à la page 357 | Seleccionar el alimentador adecuado a la página 357 | Der passende Stromversorgung auf Seite 357 wählen

LED esterno per pensili e mensole con interruttore touch

External LED for wall cabinets and shelves with touch switch
LED externe pour modules suspendus et étagères avec interrupteur tactile
LED exterior con interruptor touch para colgantes y baldas
Externe LED für Hängeschränke und Regale mit Touch-Schalter

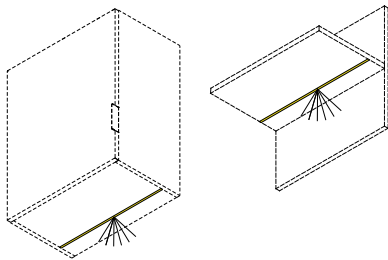

Led Dual Color (3000 - 4000 K) dimmerabile
Dual Colour Led (3000 - 4000 K) Dimmable
LED Dual Color(3000 - 4000 K) avec dimmer
LED bicolor (3000 - 4000 K) regulable
Dual Colour LED (3000 - 4000 K) dimmbar

L/W	WATT	CODICE	PUNTI
40,5	6	KILT1040	70
41,3	6	KILT1041	70
55,5	8	KILT1055	76
56,3	8	KILT1056	77
63,2	9	KILT1063	79
70,5	11	KILT1070	83
71,3	11	KILT1071	84
85,5	13	KILT1085	90
86,3	13	KILT1086	90
91,3	14	KILT1091	92
100,5	15	KILT1100	97
101,3	15	KILT1101	98
115,5	17	KILT1115	104
116,3	17	KILT1116	104
al ml	14	KILT2000	108

Selezionare l'alimentatore adatto a pag. 357

Select the appropriate power supply on p.357 | Sélectionner le bloc d'alimentation approprié à la page 357 | Seleccionar el alimentador adecuado a la página 357 | Der passende Stromversorgung auf Seite 357 wählen

Basi con maniglia
Base units with handle

Basi con gola
Base units with groove

Colonne
Tall units

Pensili
Wall units

Elementi speciali
Special elements

Maniglie gole zoccoli
Handles grooves plinth

Illuminazione
Lighting

Accessori
Accessories

Componenti e meccanismi
Components e mechanism

LUCE LED AD INCASSO

Recessed led light
Eclairage LED encastré
Luz led empotrada
LED-Einbauleuchte

LED interno orizzontale per moduli a giorno

Horizontal interior LED for open modules
LED horizontale intérieure pour modules ouverts
LED interior horizontal para módulos abiertos
Horizontale Innen-LED für offene Module

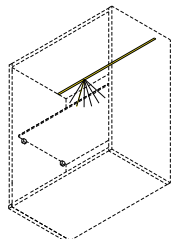

LED Dual Color (3000 - 4000 K) non dimmerabile
Dual Colour Led (3000 - 4000 K) not dimmable
LED Dual Color(3000 - 4000 K) non graduabile
LED bicolor (3000 - 4000 K) no regulable
Dual Colour LED(3000 - 4000 K) nicht dimmbar

L/W	WATT	CODICE	PUNTI
40,5	6	KILS304050R	48
55,5	8	KILS305550R	55
72,5	11	KILS307250R	63
87,5	13	KILS308750R	70
102,5	15	KILS310250R	77
117,5	18	KILS311750R	83
al ml	14	KILS400000R	79

Selezionare l'alimentatore adatto a pag. 357

Select the appropriate power supply on p.357 | Sélectionner le bloc d'alimentation approprié à la page 357 | Seleccionar el alimentador adecuado a la página 357 | Der passende Stromversorgung auf Seite 357 wählen

LED interno orizzontale per moduli con anta

Horizontal interior LED for modules with sash
LED horizontale intérieure pour modules avec porte
LED horizontal interior para módulos con puerta
Horizontale Innen-LED für Türmodule

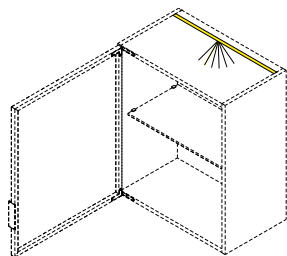

LED Dual Color (3000 - 4000 K) non dimmerabile
Dual Colour Led (3000 - 4000 K) not dimmable
LED Dual Color(3000 - 4000 K) non graduabile
LED bicolor (3000 - 4000 K) no regulable
Dual Colour LED(3000 - 4000 K) nicht dimmbar

L/W	WATT	CODICE	PUNTI
41,2	6	KILS304120R	49
56,2	8	KILS305620R	55
71,2	11	KILS307120R	62
72,4	11	KILS307240R	63
86,2	13	KILS308620R	69
91,2	14	KILS309120R	71
101,2	15	KILS310120R	76
116,2	17	KILS311620R	83
al ml	14	KILS400000R	79

Selezionare l'alimentatore adatto a pag. 357 e aggiungere il sensore di presenza.

Select the appropriate power supply on p. 357. In the case of internal LED, the presence sensor must be added. | Sélectionnez le bloc d'alimentation approprié à la page 357 et rajoutez le capteur de présence | Seleccionar el alimentador adecuado a la página 357. En el caso de LED interno añadir el sensor de presencia. | Wählen Sie das entsprechende Netzteil auf Seite 357. Im Falle einer internen LED muss der Bewegungssensor hinzugefügt werden.

LUCE LED AD INCASSO

Recessed led light
Eclairage LED encastré
Luz led empotrada
LED-Einbauleuchte

LED interno verticale per moduli con anta

Vertical interior LED for modules with sash
LED verticale intérieure pour modules avec porte
LED interior vertical para módulos con puerta
Vertikale Innen-LED für Türmodule

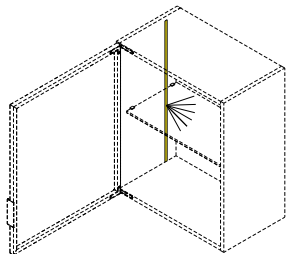

Led Dual Color (3000 - 4000 K) non dimmerabile
Dual Colour Led (3000 - 4000 K) not dimmable
LED Dual Color(3000 - 4000 K) non graduabile
LED bicolor (3000 - 4000 K) no regulable
Dual Colour LED (3000 - 4000 K) nicht dimmbar

H/H	WATT	CODICE	PUNTI
35,3	5	KILS30353VR	47
41,8	6	KILS30418VR	49
53,3	8	KILS30533VR	53
68,3	10	KILS30683VR	61
74,3	11	KILS30743VR	63
83,3	12	KILS30833VR	67
98,3	15	KILS30983VR	72
128,3	19	KILS31283VR	91
191,3	29	KILS31913VR	123
206,3	31	KILS32063VR	128
221,3	33	KILS32213VR	133
226,3	35	KILS32363VR	140
al ml	14	KILS40000VR	79

Selezionare l'alimentatore adatto a pag. 357 e aggiungere il sensore di presenza.

Select the appropriate power supply on p. 357. In the case of internal LED, the presence sensor must be added. | Sélectionnez le bloc d'alimentation approprié à la page 357 et rajoutez le capteur de présence | Seleccionar el alimentador adecuado a la página 357. En el caso de LED interno añadir el sensor de presencia. | Wählen Sie das entsprechende Netzteil auf Seite 357. Im Falle einer internen LED muss der Bewegungssensor hinzugefügt werden.

Basi con maniglia
Base units with handle

Basi con gola
Base units with groove

Colonne
Tall units

Pensili
Wall units

Elementi speciali
Special elements

Maniglie gole zoccoli
Handles grooves plinth

Illuminazione
Lighting

Accessori
Accessories

Componenti e meccanismi
Components e mechanism

PROFILO LED

LED profile
Profil LED
Perfil LED
LED-Profil

DESCRIZIONE Estruso di alluminio verniciato colore nero RAL 7021 con diffusore in policarbonato opalino. Dispositivo LED Dual Color (3000 °K - 4000 °K) alimentato a 24V, consumo 14,4 W/ml. Sensore di prossimità integrato nella lampada.

APPLICAZIONE Nel lato superiore interno di basi con anta battente o estraibile. Fissaggio mediante agganci laterali e viti autofilettanti.

COLLEGAMENTO L'accensione avviene mediante sensore di prossimità integrato nella lampada. In questo caso la dimmerazione non è possibile.

DESCRIPTION Extruded aluminum painted black RAL 7021 colour with opal polycarbonate diffuser. Dual Colour LED device (3000 °K - 4000 °K) powered at 24V, consumption 14.4 W/ml. Proximity sensor integrated in the lamp.

APPLICATION In the upper inner side of base units with hinged or pull-out doors. Fastening by means of side hooks and self-tapping screws.

LINK Ignition is by proximity sensor built into the lamp. Dimming is not possible in this case.

DESCRIPTION Aluminium extrudé peint en noir RAL 7021 avec diffuseur en polycarbonate opale. Dispositif LED bicolore (3000 °K - 4000 °K) alimenté à 24 V, consommation 14,4 W/ml. Capteur de proximité intégré dans la lampe.

APPLICATION Sur la face supérieure intérieure des meubles bas avec porte battante ou coulissante. Fixation à l'aide de crochets latéraux et de vis autotaraudeuses.

CONNEXION L'allumage se fait au moyen d'un capteur de proximité intégré dans la lampe. La gradation n'est pas possible dans ce cas.

DESCRIPCIÓN Aluminio extruido pintado de negro RAL 7021 con difusor de policarbonato opalino. Dispositivo LED bicolor (3000 °K - 4000 °K) alimentado a 24 V, consumo 14,4 W/ml. Sensor de proximidad integrado en la lámpara.

APLICACIÓN En la parte superior interior de las bases con puerta batiente o extraíble. Fijación mediante ganchos laterales y tornillos autorroscantes.

ENLACE El encendido se realiza mediante un sensor de proximidad integrado en la lámpara. En este caso no es posible la regulación.

BESCHREIBUNG Stranggepresstes Aluminium schwarz lackiert RAL 7021 mit opalem Polycarbonat-Diffusor. Dual Colour LED-Gerät (3000 °K - 4000 °K) mit 24 V betrieben, Verbrauch 14,4 W/ml. Bewegungssensor in der Leuchte integriert.

ANMELDUNG An der Innenseite der Oberseite von Unterschränken mit aufklappbarer oder ausziehbarer Tür. Befestigung mit Seitenhaken und Holzschrauben.

VERBINDUNG Die Zündung erfolgt über einen in der Lampe integrierten Bewegungssensor. Dimmen ist in diesem Fall nicht möglich.

Profilo LED esterno per pensili (da 30 a 300 cm)

External LED profile for wall units (30 to 300 cm)

Profil LED externe pour modules suspendus (30 à 300 cm)

Perfil LED exterior para colgantes (de 30 a 300 cm)

LED-Außenprofil für Hängeschrank (30 bis 300 cm)

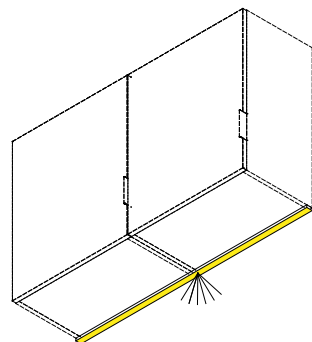

Led Dual Color (3000 - 4000 K) interruttore touch integrato dimmerabile

Dual Colour Led (3000 - 4000 K) built-in touch switch dimmable

Led Dual Color (3000 - 4000 K) avec interrupteur tactile intégré et gradable

Led de doble color (3000 - 4000 K) con interruptor touch integrado regulable

Dual Colour Led (3000 - 4000 K) integrierter Touch-Schalter dimmbar

L/W	WATT	CODICE	PUNTI
al ml	14	KILW1000	86

Selezionare l'alimentatore adatto a pag. 357

Select the appropriate power supply on p.357 | Sélectionner le bloc d'alimentation approprié à la page 357 | Seleccionar el alimentador adecuado a la página 357 | Der passende Stromversorgung auf Seite 357 wählen

PROFILO LED

LED profile
 Profil LED
 Perfil LED
 LED-Profil

Profilo LED telaio scolapiatti

LED profile dish drainer frame
 Profil Led pour cadre égouttoire
 Perfil LED para escurridor
 LED-Geschirrständerprofil

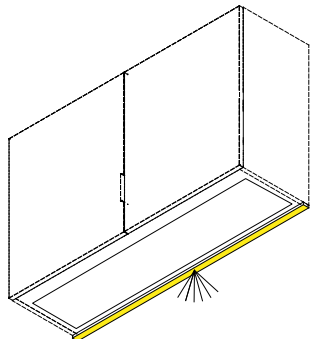

L/W	WATT	CODICE	PUNTI
413	6	KILB1041	212
563	8	KILB1056	212
713	11	KILB1071	271
863	13	KILB1086	271
1.013	15	KILB1101	327
1.163	17	KILB1116	327

Selezionare l'alimentatore adatto a pag. 357

Select the appropriate power supply on p.357 | Sélectionner le bloc d'alimentation approprié à la page 357 | Seleccionar el alimentador adecuado a la página 357 | Der passende Stromversorgung auf Seite 357 wählen

Profilo LED interno per basi con cestone

Interior LED profile for base units with basket
 Profil LED intérieur pour bases avec panier
 Perfil LED interior para bases con cajón
 LED-Innenprofil für Unterschränke mit Schublade

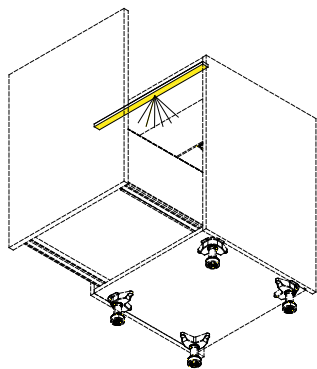

Led Dual Color (3000 - 4000 K) sensore di prossimità integrato non dimmerabile

Dual Colour Led (3000 - 4000 K) integrated proximity sensor not dimmable
 LED Dual Color (3000 - 4000 K) capteur de proximité intégré non graduable
 LED bicolor (3000 - 4000 K) sensor de proximidad integrado no regulable
 Dual Colour LED (3000 - 4000 K) integrierter Bewegungssensor nicht dimmbar

L/W	WATT	CODICE	PUNTI
41,3	6	KILI1041	91
56,3	8	KILI1056	100
71,3	11	KILI1071	111
86,3	13	KILI1086	121
116,3	17	KILI1116	139

Selezionare l'alimentatore adatto a pag. 357

Select the appropriate power supply on p.357 | Sélectionner le bloc d'alimentation approprié à la page 357 | Seleccionar el alimentador adecuado a la página 357 | Der passende Stromversorgung auf Seite 357 wählen

Basi con maniglia
 Base units with handle

Basi con gola
 Base units with groove

Colonne
 Tall units

Pensili
 Wall units

Elementi speciali
 Special elements

Maniglie gole zoccoli
 Handles grooves plinth

Illuminazione
 Lighting

Accessori
 Accessories

Componenti e meccanismi
 Components e mechanism

PROFILO LED

LED profile
Profil LED
Perfil LED
LED-Profil

Profilo LED interno per basi con anta battente

Interior LED profile for base units with hinged door
Profil LED intérieur pour bases avec porte battante
Perfil LED interior para bases puerta batiente
LED-Innenprofil für Unterschränke mit Flügeltür

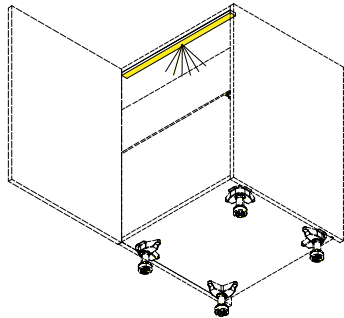

Led Dual Color (3000 - 4000 K) sensore di prossimità integrato non dimmerabile

Dual Colour Led (3000 - 4000 K) integrated proximity sensor not dimmable
LED Dual Color (3000 - 4000 K) capteur de proximité intégré non graduable
LED bicolor (3000 - 4000 K) sensor de proximidad integrado no regulable
Dual Colour LED (3000 - 4000 K) integrierter Bewegungssensor nicht dimmbar

L/W	WATT	CODICE	PUNTI
41,3	6	KILI1041	91
56,3	8	KILI1056	100
71,3	11	KILI1071	111
86,3	13	KILI2086	152
116,3	17	KILI2116	171

Selezionare l'alimentatore adatto a pag. 357

Select the appropriate power supply on p.357 | Sélectionner le bloc d'alimentation approprié à la page 357 | Seleccionar el alimentador adecuado a la página 357 | Der passende Stromversorgung auf Seite 357 wählen

SCHIENALE LUMINOSO

Luminous backrest
 Dos lumineux
 Trasera iluminada
 Beleuchtete Rückwand

DESCRIZIONE Pannello composto da metacrilato speciale e completo di telaio con LED che grazie ad una innovazione tecnologia permette la diffusione omogenea della luce.

Colore luce LED 3000°K, regolabile ad 2700 a 6500°K con telecomando optional.

APPLICAZIONE Schienali (non direttamente in appoggio sopra il top o le basi).

COLLEGAMENTO L'accensione avviene mediante telecomando (ogni alimentatore ha un ricevente che comanda il telecomando). Il collegamento all'impianto domestico (interruttore a cura del cliente) non permette la dimmerazione e il cambio colore.

DESCRIPTION Panel composed of special methacrylate and complete with LED frame, which thanks to an innovative technology allows homogeneous light diffusion.

LED light colour 3000°K, adjustable to 2700 to 6500°K with optional remote control.

APPLICATION Backrests (not directly resting on top of the top or base units).

CONNECTION Power is turned on by remote control (each ballast has a receiver that controls the remote control). Connection to the household system (switch by customer) does not allow dimming and colour change.

DESCRIPTION Panneau en méthacrylate spécial, équipé d'un cadre LED qui, grâce à une technologie innovante, permet une diffusion homogène de la lumière.

Couleur de la lumière LED 3000°K, réglable de 2700 à 6500°K avec la télécommande optionnelle.

APPLICATION Dos (pas directement appuyé sur plateau ou sur la base).

CONNEXION L'allumage se fait par télécommande (chaque transfo est équipé d'un récepteur qui commande la télécommande). La connexion à l'installation domestique (interrupteur par le client) ne permet pas la gradation et le changement de couleur.

DESCRIPCIÓN Panel fabricado en metacrilato especial y marco con LED, que gracias a una innovadora tecnología permite una difusión homogénea de la luz.

Color de la luz LED 3000°K, regulable de 2700 a 6500°K con mando a distancia opcional.

APLICACIÓN Respaldos (no directamente sobre la encimera o la base).

CONEXIÓN El encendido se realiza por mando a distancia (cada alimentador tiene un receptor que controla el mando a distancia). La conexión a la red eléctrica de la habitación (interruptor a cargo del cliente) no permite la regulación ni el cambio de color.

BESCHREIBUNG Paneel aus speziellem Methacrylat und komplett mit LED-Rahmen, der dank einer innovativen Technologie eine homogene Lichtstreuung ermöglicht.

LED-Lichtfarbe 3000°K, einstellbar von 2700 bis 6500°K mit optionaler Fernbedienung.

ANWENDUNG Rückwand (nicht direkt über der Platte oder dem Sockel).

VERBINDUNG Das Einschalten erfolgt per Fernbedienung (jedes Vorschaltgerät hat einen Empfänger, der die Fernbedienung steuert). Der Anschluss an die Hausinstallation (bauseitiger Schalter) erlaubt kein Dimmen und keinen Farbwechsel.

Schienale luminoso

Luminous backrest
 Dos lumineux
 Trasera iluminada
 Beleuchtete Rückwand

Dimensione minima pannello: 30x30 cm | Dimensione massima pannello: 240x140 cm

Minimum panel size: 30x30 cm | Maximum panel size: 240x140 cm

Taille minimale du panneau : 30x30 cm | Taille maximale du panneau : 240x140 cm

Tamaño mínimo del panel: 30x30 cm | Tamaño máximo del panel: 240x140 cm

Mindestgröße der Paneel: 30x30 cm | Maximale Paneelgröße: 240x140 cm

CODICE

PUNTI

al mq <=1

KILSHINFMQ

998

al mq >=1,1

KILSHSUPMQ

928



Basi con maniglia
 Base units with handle

Basi con gola
 Base units with groove

Colonne
 Tall units

Pensili
 Wall units

Elementi speciali
 Special elements

Maniglie gole zoccoli
 Handles grooves plinth

Illuminazione
 Lighting

Accessori
 Accessories

Componenti e meccanismi
 Components e mechanism

ILLUMINAZIONE INTERNO CASSETTI

Internal drawer lighting
Eclairage intérieur des tiroirs
Iluminación interior de cajones
Innenbeleuchtung der Schubladen

DESCRIZIONE Profilo in materiale plastico applicabile sul lato superiore delle sponde di cassetti e cestoni. Colore luce LED 4000° K. il set comprende la coppia di profili (sx e dx), batteria, carica batteria, cavi e materiale per il fissaggio.

APPLICAZIONE Cassetti e cestoni.

BATTERIA Con una media di 10 aperture giornaliere del cassetto è prevista una durata della batteria di circa un anno.

DESCRIPTION Plastic profile applicable on the upper side of the sides of drawers and baskets. LED light colour 4000° K. Set includes the pair of profiles (left and right), battery, battery charger, cables and fixing material.

APPLICATION Drawers and baskets.

BATTERY With an average of 10 daily drawer openings, a battery life of about one year is expected.

DESCRIPTION Profilé en plastique pour fixation sur la face supérieure des tiroirs et des paniers. Lumière LED de couleur 4000° K. Le kit comprend une paire de profils (gauche et droite), une batterie, un chargeur de batterie, des câbles et du matériel de fixation.

APPLICATION Tiroirs et paniers.

BATTERIE Avec une moyenne de 10 ouvertures de tiroirs par jour, la durée de vie de la batterie est d'environ un an.

DESCRIPCIÓN Perfil de plástico para fijar en la parte superior de los lados de cajones y cestas. Luz LED de color 4000° K. Incluye la pareja de perfiles (izquierdo y derecho), batería, cargador de batería, cables y material de fijación.

APLICACIÓN Cajones y cestas.

BATERÍA Con una media de 10 aperturas de cajones al día, se prevee una duración de las pilas de aproximadamente un año.

BESCHREIBUNG Kunststoffprofil zur Befestigung an der Oberseite von Schubladen- und Schubkastseiten. LED-Farblicht 4000° K. Das Set enthält ein Paar Profile (links und rechts), Akku, Ladegerät, Kabel und Befestigungsmaterial.

ANWENDUNG Schubladen und Schubkasten.

BATTERIE Bei durchschnittlich 10 Öffnungen pro Tag wird der Batterielebensdauer in etwa einem Jahr gerechnet.

Set profili di design con luce a led a batteria

Design profile set with battery-operated LED light
Set profil design avec lumière LED alimentée par piles
Set de perfiles design con luz LED a pilas
Design-Profilset mit batteriebetriebenem LED-Licht

Per cassetti e cestoni
For drawers and baskets
Pour tiroirs et paniers
Para cajones y cestas
Für Schubladen und Schubkasten



L/W	CODICE	PUNTI
50	HYPR2501	129
60	HYPR2601	134

SISTEMI DI ALIMENTAZIONE

Power systems
Systèmes d'alimentation
Sistemas de alimentación
Fütterungssysteme

Alimentatore con spina EU o USA e distributore multiplo

Power supply with EU or US plug and multi-distributor
Alimentation électrique avec prise UE ou Usa et multi-distributeur
Alimentador con enchufe UE o EE.UU. y multidistribuidor
Netzgerät mit EU- oder US-Stecker und Mehrfachverteiler

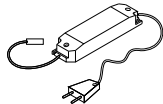

6 lampade o 6 sensori per ogni alimentatore
6 lamps or 6 sensors for each feeder
6 lampes ou 6 capteurs par chaque alimentation électrique
6 lámparas o 6 sensores cada alimentador
6 Lampen oder 6 Sensoren pro Stromversorger

	WATT	CODICE	PUNTI
EU	30	KILA1030W	45
EU	75	KILA1075W	72
EU	100	KILA1100W	93
USA	30	KILA2030W	49
USA	75	KILA2075W	74
USA	96	KILA2100W	96

Centralina e telecomando per accensione e dimmerazione Led

Control unit and remote control for switching and dimming LEDs
Unité de commande et télécommande pour l'allumage et la gradation des LED
Unidad de control y mando a distancia para conmutar y regular los LED
Steuergerät und Fernbedienung zum Schalten und Dimmen von LEDs

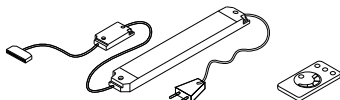

Con distributore multiplo a 3 posizioni
With 3-position multi-distributor
Avec distributeur multiple à 3 positions
Con distribuidor múltiple de 3 posiciones
Mit 3-Positionen-Mehrfachverteiler

	CODICE	PUNTI
Centralina	KILS00000002	104
Telecomando	KILS00000003	65

Basi con maniglia
Base units with handle

Basi con gola
Base units with groove

Colonne
Tall units

Pensili
Wall units

Elementi speciali
Special elements

Maniglie gole zoccoli
Handles grooves plinth

Illuminazione
Lighting

Accessori
Accessories

Componenti e meccanismi
Components e mechanism

ACCESSORI

Accessories
Accessoires
Accesorios
Zubehör

TAPPETTINI PER CASSETTI E CESTONI Drawer and basket mats Tapis pour tiroirs et paniers Alfombrillas para cajones y cestas Matten für Schubladen und Schubka-	P. 304
PORTAPOSATE Cutlery tray Porte-couverts Cubertero Besteckkasten	P. 305
<ul style="list-style-type: none"> • SKY LINE P. 305 • LINEA FIT P. 308 	
ACCESSORI DISPENSA Pantry accessories Accessoires pour le garde-manger Accesorios para despensa Zubehör für die Schränke	P. 317
<ul style="list-style-type: none"> • LINEA FIT P. 317 • LINEA FRAME P. 327 	
ACCESSORI COLONNE RIENTRANTI Accessories for pocket doors tall units Accessoires colonnes portes rentrantes Accesorios columnas retráctiles Zubehör versenkbare Schränke	P. 331
PATTUMIERE Dustbins Poubelles Papeleras Abfalleimer	P. 337
<ul style="list-style-type: none"> • T2 P. 337 • BASE SYSTEM Base System Base Système Base System Basis-System P. 339 • ESTRAIBILE PER ANTA Removable by sash Extractible pour porte Extraible para puerta Auszug für Tür P. 341 	
SISTEMA HANG Hang System Système Hang Sistema Hang System Hang	P. 342
<ul style="list-style-type: none"> • SISTEMA HANG SOTTOPENSILE Under-cabinet Hang System Système de suspension sous l'armoire Sistema Hang bajo colgante Unterschrank-Hängesystem P. 342 • SISTEMA HANG SOPRAPIANO Hang overhead system Système de suspension Sistema Hang sobre encimera Hang system ueber top P. 343 • ACCESSORI HANG Hang Accessories Accessoires Hang Accesorios Hang Zubehör aufhängen P. 344 	
ACCESSORI LINERO MOSAIO Linero MosaiQ accessories Accessoires Linero MosaiQ Accesorios Linero MosaiQ Zubehör Linero MosaiQ	P. 346
BARRA ELETTRIFICATA Electrified bar Barre électrifiée Barra electrificada Elektrifizierter Stab	P. 350

Basi con maniglia
Base units with handle

Basi con gola
Base units with groove

Colonne
Tall units

Pensili
Wall units

Elementi speciali
Special elements

Maniglie gole zoccoli
Handles grooves plinth

Illuminazione
Lighting

Accessori
Accessories

Componenti e meccanismi
Components e mechanism

TAPPETTINI PER CASSETTI E CESTONI

Drawer and basket mats
Tapis pour tiroirs et paniers
Alfombrillas para cajones y cestas
Matten für Schubladen und Schubkasten

Tappetini per interno cassetto disponibili in polivinile espanso antracite con finitura antiscivolo e anima in tessuto (senza memoria di forma) o in tessuto tecnico tex-mat grigio acciaio costituito da fibre di poliestere con caratteristiche di morbidezza al tatto e resistenza alle abrasioni. Interior drawer mats available in anthracite polyvinyl foam with non-slip finish and fabric core (without memory) or in steel grey tex-mat technical fabric made of polyester fibres with soft-touch and abrasion-resistant characteristics.

Interior drawer mats available in anthracite polyvinyl foam with non-slip finish and fabric core (without memory) or in steel grey tex-mat technical fabric made of polyester fibres with soft-touch and abrasion-resistant characteristics.

Alfombrillas para interior de cajones disponibles en espuma de polivinilo antracita con acabado antideslizante y núcleo de tejido (sin memoria) o en tejido técnico tex-mat gris acero de fibras de poliéster con características suaves al tacto y resistentes a la abrasión.

Matten für Innenschubladen aus anthrazitfarbenem Polyvinylschaum mit rutschfester Oberfläche und Gewebekern (ohne Memory-Schaum) oder aus stahlgrauem technischem Gewebe tex-mat aus Polyesterfasern mit Soft-Touch- und abriebfesten Eigenschaften erhältlich.

Tapis intérieurs pour tiroirs disponibles en mousse de polyvinyle anthracite avec finition antidérapante et âme en tissu (sans mémoire) ou en tissu technique tex-mat gris acier composé de fibres de polyester aux caractéristiques douces au toucher et résistantes à l'abrasion.

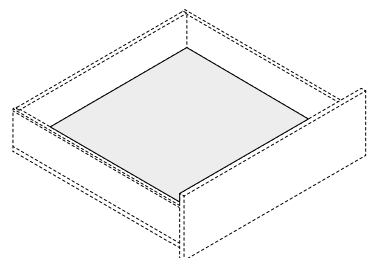

Tappetino antiscivolo in polivinile espanso con anima in tessuto

Non-slip polyvinyl foam mat with fabric core

Tapis antidérapant en mousse de polyvinyle avec âme en tissu

Alfombrilla de espuma de polivinilo antideslizante con núcleo de tela

Rutschfeste Polyvinylschaum-Matte mit Gewebekern

Finitura antracite

Anthracite finish

Finition anthracite

Acabado antracita

Ausführung Anthrazit



P/D	L/W	CODICE	PUNTI
50	45	KAT0104550AT	7
50	60	KAT0106050AT	10
50	75	KAT0107550AT	13
50	90	KAT0109050AT	15
50	105	KAT0110550AT	18
50	120	KAT0112050AT	21
60	45	KAT0104560AT	10
60	60	KAT0106060AT	13
60	75	KAT0107560AT	17
60	90	KAT0109060AT	20
60	105	KAT0110560AT	24
60	120	KAT0112060AT	28

Tappetino antiscivolo in tessuto tecnico TEX MAT

Non-slip mat made of technical fabric TEX MAT

Tapis antidérapant en tissu technique TEX MAT

Alfombrilla antideslizante de tejido técnico TEX MAT

Antirutschmatte aus technischem Gewebe TEX MAT

Finitura grigio acciaio

Steel gray finish

Finition gris acier

Acabado gris acero

Ausführung Stahlgrau



P/D	L/W	CODICE	PUNTI
50	45	KAT0204550TM	31
50	60	KAT0206050TM	40
50	75	KAT0207550TM	50
50	90	KAT0209050TM	60
50	105	KAT0210550TM	70
50	120	KAT0212050TM	82
60	45	KAT0204560TM	39
60	60	KAT0206060TM	51
60	75	KAT0207560TM	63
60	90	KAT0209060TM	76
60	105	KAT0210560TM	87
60	120	KAT0212060TM	103

PORTAPOSATE

Cutlery tray
Porte-couverts
Cubertero
Besteckkasten

SKY LINE

Portaposate per cassetto L. 45

Cutlery tray for drawer W. 45
Range-couverts pour tiroir L. 45
Cubertero para cajón L. 45
Besteckkast für Schublade B. 45

ABS finitura grigio scuro
ABS dark grey finish
ABS finition gris foncé
ABS acabado gris oscuro
ABS dunkelgrau lackiert

P/D	L/W	CODICE	PUNTI
50	45	KPP01045	18

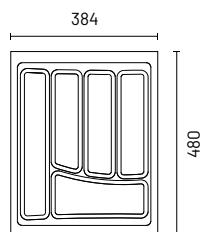

Portaposate per cassetto L. 60

Cutlery tray for drawer W. 60
Range-couverts pour tiroir L. 60
Cubertero para cajón L. 60
Besteckkast für Schublade B. 60

ABS finitura grigio scuro
ABS dark grey finish
ABS finition gris foncé
ABS acabado gris oscuro
ABS dunkelgrau lackiert

P/D	L/W	CODICE	PUNTI
50	60	KPP01060	21

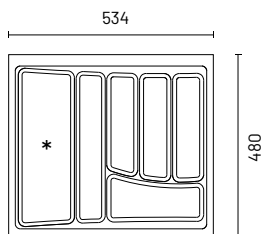

* vano per inserti | compartment for inserts | compartiment pour les inserts | compartimiento para insertos | fach für Einsätze

Portaposate per cassetto L. 75

Cutlery tray for drawer W. 75
Range-couverts pour tiroir L. 75
Cubertero para cajón L. 75
Besteckkast für Schublade B. 75

ABS finitura grigio scuro
ABS dark grey finish
ABS finition gris foncé
ABS acabado gris oscuro
ABS dunkelgrau lackiert

P/D	L/W	CODICE	PUNTI
50	75	KPP01075	35

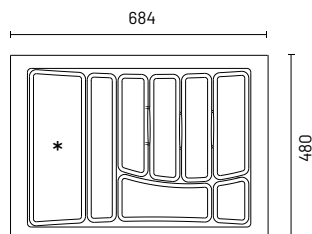

* vano per inserti | compartment for inserts | compartiment pour les inserts | compartimiento para insertos | fach für Einsätze

Basi con maniglia
Base units with handle

Basi con gola
Base units with groove

Colonne
Tall units

Pensili
Wall units

Elementi speciali
Special elements

Maniglie gole zoccoli
Handles grooves plinth

Illuminazione
Lighting

Accessori
Accessories

Componenti e meccanismi
Components e mechanism

PORTAPOSATE

Cutlery tray
Porte-couverts
Cubertero
Besteckkasten

SKY LINE

Portaposate per cassetto L. 90
Cutlery tray for drawer W. 90
Range-couverts pour tiroir L. 90
Cubertero para cajón L. 90
Besteckkast für Schublade B. 90

ABS finitura grigio scuro
ABS dark grey finish
ABS finition gris foncé
ABS acabado gris oscuro
ABS dunkelgrau lackiert

P/D	L/W	CODICE	PUNTI
50	90	KPP01090	42

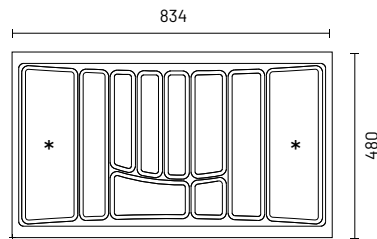

* vano per inserti | compartment for inserts | compartiment pour les inserts | compartimiento para insertos | fach für Einsätze

Portaposate per cassetto L. 105
Cutlery tray for drawer W. 105
Range-couverts pour tiroir L. 105
Cubertero para cajón L. 105
Besteckkast für Schublade B. 105

ABS finitura grigio scuro
ABS dark grey finish
ABS finition gris foncé
ABS acabado gris oscuro
ABS dunkelgrau lackiert

P/D	L/W	CODICE	PUNTI
50	105	KPP01105	70

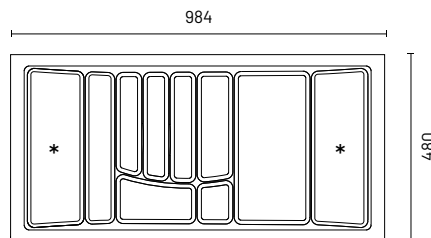

* vano per inserti | compartment for inserts | compartiment pour les inserts | compartimiento para insertos | fach für Einsätze

Portaposate per cassetto L. 120
Cutlery tray for drawer W. 120
Range-couverts pour tiroir L. 120
Cubertero para cajón L. 120
Besteckkast für Schublade B. 120

ABS finitura grigio scuro
ABS dark grey finish
ABS finition gris foncé
ABS acabado gris oscuro
ABS dunkelgrau lackiert

P/D	L/W	CODICE	PUNTI
50	120	KPP01120	77

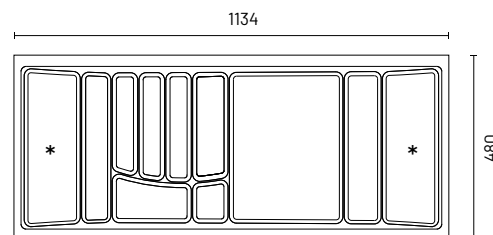

* vano per inserti | compartment for inserts | compartiment pour les inserts | compartimiento para insertos | fach für Einsätze

INSERTI PORTAPOSATE

Cutlery tray
Porte-couverts
Cubertero
Besteckkasten

SKY LINE

Inserto double face in faggio (portacoltelli un lato e tagliere lato opposto)

Beech double face insert (knife holder one side and cutting board opposite side)
Insert en hêtre double face (porte-couteau d'un côté et planche à découper de l'autre)
Inserto de doble cara en haya (portacuchillos por un lado y tabla de cortar por el lado opuesto)
Doppelseitiger Einsatz aus Buche (Messerhalter auf der einen Seite und Schneidebrett auf der anderen Seite)



P/D	L/W	CODICE	PUNTI
39	135	KPP000000001	59

Inserto in plastica con 2 portapellicole

Plastic insert with 2 film holders
Insert en plastique avec 2 porte-pellicule
Inserto de plástico con 2 portapelículas
Kunststoffeinsatz mit 2 Folienhaltern



P/D	L/W	CODICE	PUNTI
41	15	KPP000000002	59

Inserto in plastica con porta oggetti scorrevole

Plastic insert with sliding object holder
Insert en plastique avec porte-objet coulissant
Inserto de plástico con portaobjetos deslizante
Kunststoffeinsatz mit verschiebbarem Gegenstände



P/D	L/W	CODICE	PUNTI
25	15	KPP000000003	38

Basi con maniglia
Base units with handle

Basi con gola
Base units with groove

Colonne
Tall units

Pensili
Wall units

Elementi speciali
Special elements

Maniglie gole zoccoli
Handles grooves plinth

Illuminazione
Lighting

Accessori
Accessories

Componenti e meccanismi
Components e mechanism

PORTAPOSATE

Cutlery tray
Porte-couverts
Cubertero
Besteckkasten

LINEA FIT

Fit Portaposate L. 45 V1

Fit Cutlery tray W. 45 V1
Fit porte-couverts L. 45 V1
Fit para cubiertos A. 45 V1
Fit Besteckkasten B. 45 V1

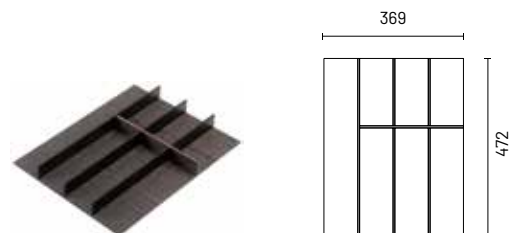

Con fondo in rovere tinto moka e divisori in alluminio anodizzato nero
With mocha-stained oak bottom and black anodized aluminum dividers
Avec fond en chêne teinté moka et séparateurs en aluminium anodisé noir
Con fondo en roble teñido acabado moka y divisorios de aluminio anodizado negro
Mit mokkagebeiztem Eichenholz und schwarz eloxierten Aluminiumtrennwänden

P/D	L/W	H/H	CODICE	PUNTI
50	45	4,8	KPP0204550MO	172
■ 60	45	4,8	KPP0204560MO	279

■ **profondità 60 composta da elemento profondità 50 cm più compensatore** | depth 60 composed of element depth 50 cm plus compensator | profondeur 60 comprenant l'élément profondeur 50 cm plus compensateur | profundidad 60 constituida por un elemento profundidad 50 cm más compensador | tiefe 60 mit Elementtiefe 50 cm plus Kompensator

Fit Portaposate L. 60 V1

Fit Cutlery tray W. 60 V1
Fit porte-couverts L. 60 V1
Fit para cubiertos A. 60 V1
Fit Besteckkasten B. 60 V1

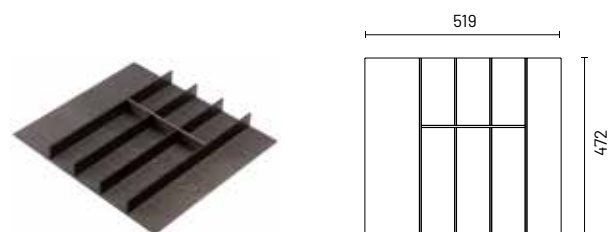

Con fondo in rovere tinto moka e divisori in alluminio anodizzato nero
With mocha-stained oak bottom and black anodized aluminum dividers
Avec fond en chêne teinté moka et séparateurs en aluminium anodisé noir
Con fondo en roble teñido acabado moka y divisorios de aluminio anodizado negro
Mit mokkagebeiztem Eichenholz und schwarz eloxierten Aluminiumtrennwänden

P/D	L/W	H/H	CODICE	PUNTI
50	60	4,8	KPP0206050MO	180
■ 60	60	4,8	KPP0206060MO	291

■ **profondità 60 composta da elemento profondità 50 cm più compensatore** | depth 60 composed of element depth 50 cm plus compensator | profondeur 60 comprenant l'élément profondeur 50 cm plus compensateur | profundidad 60 constituida por un elemento profundidad 50 cm más compensador | tiefe 60 mit Elementtiefe 50 cm plus Kompensator

Fit Portaposate L. 75 V1

Fit Cutlery tray W. 75 V1
Fit porte-couverts L. 75 V1
Fit para cubiertos A. 75 V1
Fit Besteckkasten B. 75 V1

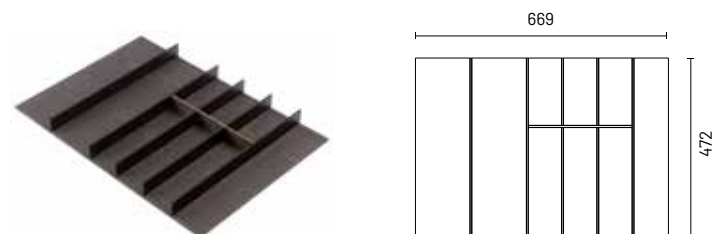

Con fondo in rovere tinto moka e divisori in alluminio anodizzato nero
With mocha-stained oak bottom and black anodized aluminum dividers
Avec fond en chêne teinté moka et séparateurs en aluminium anodisé noir
Con fondo en roble teñido acabado moka y divisorios de aluminio anodizado negro
Mit mokkagebeiztem Eichenholz und schwarz eloxierten Aluminiumtrennwänden

P/D	L/W	H/H	CODICE	PUNTI
50	75	4,8	KPP0207550MO	269
■ 60	75	4,8	KPP0207560MO	387

■ **profondità 60 composta da elemento profondità 50 cm più compensatore** | depth 60 composed of element depth 50 cm plus compensator | profondeur 60 comprenant l'élément profondeur 50 cm plus compensateur | profundidad 60 constituida por un elemento profundidad 50 cm más compensador | tiefe 60 mit Elementtiefe 50 cm plus Kompensator

PORTAPOSATE

Cutlery tray
Porte-couverts
Cubertero
Besteckkasten

LINEA FIT

Fit Portaposate L. 90 V1

Fit Cutlery tray W. 90 V1
Fit porte-couverts L. 90 V1
Fit para cubiertos A. 90 V1
Fit Besteckkasten B. 90 V1

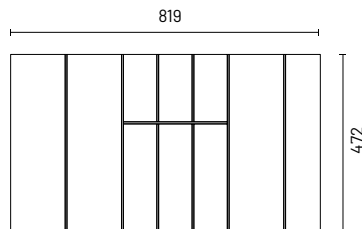

Con fondo in rovere tinto moka e divisori in alluminio anodizzato nero
With mocha-stained oak bottom and black anodized aluminum dividers
Avec fond en chêne teinté moka et séparateurs en aluminium anodisé noir
Con fondo en roble teñido acabado moka y divisorios de aluminio anodizado negro
Mit mokkagebeiztem Eichenholz und schwarz eloxierten Aluminiumtrennwänden

P/D	L/W	H/H	CODICE	PUNTI
50	90	4,8	KPP0209050MO	281
■ 60	90	4,8	KPP0209060MO	405

■ **profondità 60 composta da elemento profondità 50 cm più compensatore** | depth 60 composed of element depth 50 cm plus compensator | profondeur 60 comprenant l'élément profondeur 50 cm plus compensateur |
profundidad 60 constituida por un elemento profundidad 50 cm más compensador | tiefe 60 mit Elementtiefe 50 cm plus Kompensator

Fit Portaposate L. 105 V1

Fit Cutlery tray W. 105 V1
Fit porte-couverts L. 105 V1
Fit para cubiertos A. 105 V1
Fit Besteckkasten B. 105 V1

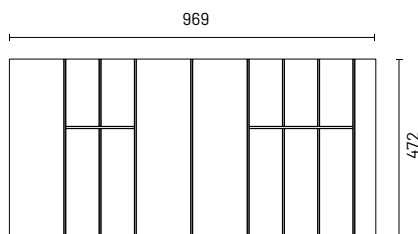

Con fondo in rovere tinto moka e divisori in alluminio anodizzato nero
With mocha-stained oak bottom and black anodized aluminum dividers
Avec fond en chêne teinté moka et séparateurs en aluminium anodisé noir
Con fondo en roble teñido acabado moka y divisorios de aluminio anodizado negro
Mit mokkagebeiztem Eichenholz und schwarz eloxierten Aluminiumtrennwänden

P/D	L/W	H/H	CODICE	PUNTI
50	105	4,8	KPP0210550MO	395
■ 60	105	4,8	KPP0210560MO	523

■ **profondità 60 composta da elemento profondità 50 cm più compensatore** | depth 60 composed of element depth 50 cm plus compensator | profondeur 60 comprenant l'élément profondeur 50 cm plus compensateur |
profundidad 60 constituida por un elemento profundidad 50 cm más compensador | tiefe 60 mit Elementtiefe 50 cm plus Kompensator

Fit Portaposate L. 120 V1

Fit Cutlery tray W. 120 V1
Fit porte-couverts L. 120 V1
Fit para cubiertos A. 120 V1
Fit Besteckkasten B. 120 V1

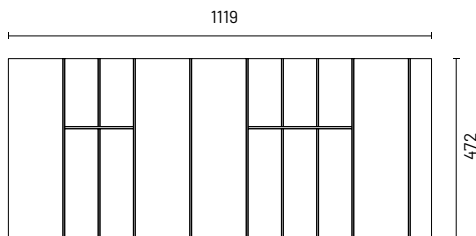

Con fondo in rovere tinto moka e divisori in alluminio anodizzato nero
With mocha-stained oak bottom and black anodized aluminum dividers
Avec fond en chêne teinté moka et séparateurs en aluminium anodisé noir
Con fondo en roble teñido acabado moka y divisorios de aluminio anodizado negro
Mit mokkagebeiztem Eichenholz und schwarz eloxierten Aluminiumtrennwänden

P/D	L/W	H/H	CODICE	PUNTI
50	120	4,8	KPP0212050MO	403
■ 60	120	4,8	KPP0212060MO	538

■ **profondità 60 composta da elemento profondità 50 cm più compensatore** | depth 60 composed of element depth 50 cm plus compensator | profondeur 60 comprenant l'élément profondeur 50 cm plus compensateur |
profundidad 60 constituida por un elemento profundidad 50 cm más compensador | tiefe 60 mit Elementtiefe 50 cm plus Kompensator

Basi con maniglia
Base units with handle

Basi con gola
Base units with groove

Colonne
Tall units

Pensili
Wall units

Elementi speciali
Special elements

Maniglie gole zoccoli
Handles grooves plinth

Illuminazione
Lighting

Accessori
Accessories

Componenti e meccanismi
Components e mechanism

PORTAPOSATE

Cutlery tray
Porte-couverts
Cubertero
Besteckkasten

LINEA FIT

Fit Porta accessori L. 45 V2

Fit Accessory holder W. 45 V2
Fit porte-accessoires L.45 V2
Fit para accesorios A.45 V2
Fit Zubehörträger B.45 V2

Con fondo in rovere tinto moka e divisori in alluminio anodizzato nero
With mocha-stained oak bottom and black anodized aluminum dividers
Avec fond en chêne teinté moka et séparateurs en aluminium anodisé noir
Con fondo en roble teñido acabado moka y divisorios de aluminio anodizado negro
Mit mokkagebeiztem Eichenholz und schwarz eloxierten Aluminiumtrennwänden

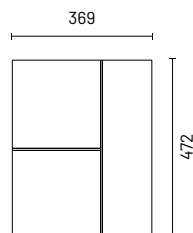

P/D	CODICE	PUNTI
50	KPP0304550MO	134
■ 60	KPP0304560MO	242

■ **profondità 60 composta da elemento profondità 50 cm più compensatore** | depth 60 composed of element depth 50 cm plus compensator | profondeur 60 comprenant l'élément profondeur 50 cm plus compensateur |
profundidad 60 constituida por un elemento profundidad 50 cm más compensador | tiefe 60 mit Elementtiefe 50 cm plus Kompensator

Fit Porta accessori L. 60 V2

Fit Accessory holder W. 60 V2
Fit porte-accessoires L.60 V2
Fit para accesorios A.60 V2
Fit Zubehörträger B.60 V2

Con fondo in rovere tinto moka e divisori in alluminio anodizzato nero
With mocha-stained oak bottom and black anodized aluminum dividers
Avec fond en chêne teinté moka et séparateurs en aluminium anodisé noir
Con fondo en roble teñido acabado moka y divisorios de aluminio anodizado negro
Mit mokkagebeiztem Eichenholz und schwarz eloxierten Aluminiumtrennwänden

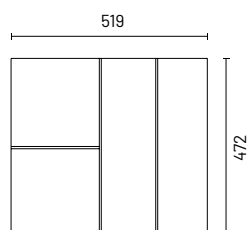

P/D	CODICE	PUNTI
50	KPP0306050MO	145
■ 60	KPP0306060MO	257

■ **profondità 60 composta da elemento profondità 50 cm più compensatore** | depth 60 composed of element depth 50 cm plus compensator | profondeur 60 comprenant l'élément profondeur 50 cm plus compensateur |
profundidad 60 constituida por un elemento profundidad 50 cm más compensador | tiefe 60 mit Elementtiefe 50 cm plus Kompensator

Fit Porta accessori L. 75 V2

Fit Accessory holder W. .75 V2
Fit porte-accessoires L.75 V2
Fit para accesorios A.75 V2
Fit Zubehörträger B.75 V2

Con fondo in rovere tinto moka e divisori in alluminio anodizzato nero
With mocha-stained oak bottom and black anodized aluminum dividers
Avec fond en chêne teinté moka et séparateurs en aluminium anodisé noir
Con fondo en roble teñido acabado moka y divisorios de aluminio anodizado negro
Mit mokkagebeiztem Eichenholz und schwarz eloxierten Aluminiumtrennwänden

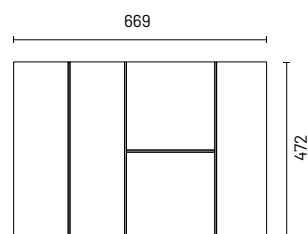

P/D	CODICE	PUNTI
50	KPP0307550MO	217
■ 60	KPP0307560MO	335

■ **profondità 60 composta da elemento profondità 50 cm più compensatore** | depth 60 composed of element depth 50 cm plus compensator | profondeur 60 comprenant l'élément profondeur 50 cm plus compensateur |
profundidad 60 constituida por un elemento profundidad 50 cm más compensador | tiefe 60 mit Elementtiefe 50 cm plus Kompensator

PORTAPOSATE

Cutlery tray
Porte-couverts
Cubertero
Besteckkasten

LINEA FIT

Fit Porta accessori L. 90 V2

Fit Accessory holder W. 90 V2
Fit porte-accessoires L.90 V2
Fit para accesorios A.90 V2
Fit Zubehörträger B.90 V2

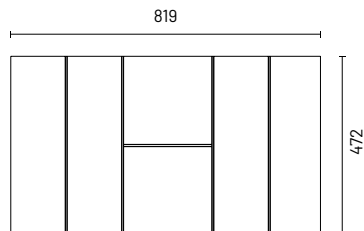

Con fondo in rovere tinto moka e divisori in alluminio anodizzato nero
With mocha-stained oak bottom and black anodized aluminum dividers
Avec fond en chêne teinté moka et séparateurs en aluminium anodisé noir
Con fondo en roble teñido acabado moka y divisorios de aluminio anodizado negro
Mit mokkagebeiztem Eichenholz und schwarz eloxierten Aluminiumtrennwänden

P/D	CODICE	PUNTI
50	KPP0309050MO	229
60	KPP0309060MO	353

Fit Porta accessori L. 105 V2

Fit Accessory holder W. 105 V2
Fit porte-accessoires L.105 V2
Fit para accesorios A.105 V2
Fit Zubehörträger B.105 V2

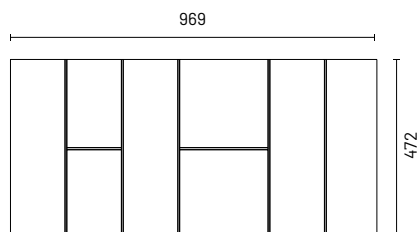

Con fondo in rovere tinto moka e divisori in alluminio anodizzato nero
With mocha-stained oak bottom and black anodized aluminum dividers
Avec fond en chêne teinté moka et séparateurs en aluminium anodisé noir
Con fondo en roble teñido acabado moka y divisorios de aluminio anodizado negro
Mit mokkagebeiztem Eichenholz und schwarz eloxierten Aluminiumtrennwänden

P/D	CODICE	PUNTI
50	KPP0310550MO	317
60	KPP0310560MO	445

Fit Porta accessori L. 120 V2

Fit Accessory holder W. 120 V2
Fit porte-accessoires L.120 V2
Fit para accesorios A.120 V2
Fit Zubehörträger B.120 V2

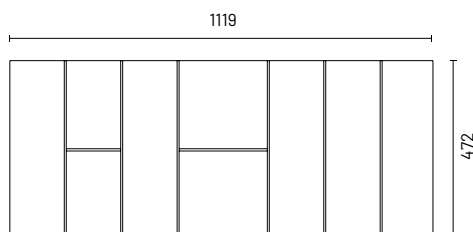

Con fondo in rovere tinto moka e divisori in alluminio anodizzato nero
With mocha-stained oak bottom and black anodized aluminum dividers
Avec fond en chêne teinté moka et séparateurs en aluminium anodisé noir
Con fondo en roble teñido acabado moka y divisorios de aluminio anodizado negro
Mit mokkagebeiztem Eichenholz und schwarz eloxierten Aluminiumtrennwänden

P/D	CODICE	PUNTI
50	KPP0312050MO	328
60	KPP0312060MO	463

Basi con maniglia
Base units with handle

Basi con gola
Base units with groove

Colonne
Tall units

Pensili
Wall units

Elementi speciali
Special elements

Maniglie gole zoccoli
Handles grooves plinth

Illuminazione
Lighting

Accessori
Accessories

Componenti e meccanismi
Components e mechanism

INSERTI PORTAPOSATE

LINEA FIT

Cutlery inserts
Insert porte-couverts
Insertos para cubiertos
Besteckhalter Einsätze

Fit Divisorio T V1

Fit Divider T V1
Fit séparateur T V1
Fit Divisorio T V1
Fit-Teiler T V1



Con fondo in rovere tinto moka e divisori in alluminio anodizzato nero
With mocha-stained oak bottom and black anodized aluminum dividers
Avec fond en chêne teinté moka et séparateurs en aluminium anodisé noir
Con fondo en roble teñido acabado moka y divisorios de aluminio anodizado negro
Mit mokkagebeiztem Eichenholz und schwarz eloxierten Aluminiumtrennwänden

P/D	L/W	H/H	CODICE	PUNTI
50	14,3	4,2	KPP000001MO	95

Fit Portacoltelli V1

Fit Knife rack V1
Fit porte-couteau V1
Fit para cuchillos V1
Fit Messerhalter V1



Con fondo e divisori in rovere tinto moka
With mocha-stained oak bottom and dividers
Avec fond et séparations en chêne teinté moka
Con fondo y divisorios en roble teñido acabado moka
Mit Boden und Trennwänden aus mokkagebeizter Eiche

P/D	L/W	H/H	CODICE	PUNTI
50	14,3	3,6	KPP000002MO	155

Fit Portapellicole V1

Fit Film Holder V1
Fit porte-pellicule V1
Fit portapelículas V1
Fit Foliehalter V1



Con fondo in rovere tinto moka e portapellicole in lamiera verniciata nera
With mocha-stained oak bottom and black painted sheet metal film holder
Avec base en chêne teinté moka et support en métal peint en noir
Con fondo de roble teñido acabado moka y soporte para película de aluminio color negro
Mit mokkagebeiztem Eichenboden und schwarz lackiertem Blechhalter

P/D	L/W	H/H	CODICE	PUNTI
50	14,3	5,6	KPP000003MO	259

INSERTI PORTAPOSATE

Cutlery inserts
Insert porte-couverts
Insertos para cubiertos
Besteckhalter Einsätze

LINEA FIT

Fit Portacialde V1

Fit V1 wafer holder
Fit porte-dosettes V1
Fit para cápsulas V1
V1-Waferhalter



Con fondo in rovere tinto moka
With mocha-stained oak bottom
Avec base en chêne teinté moka
Con base de roble teñido acabado moka
Mit Boden aus mokkagebeizter Eiche

P/D	L/W	H/H	CODICE	PUNTI
50	14,3	1,2	KPP0000004MO	146

Fit Portaspezie universale V1

Fit Universal spice rack V1
Fit porte-épices universel V1
Fit especiero universal V1
Fit Universal Gewürzregal V1



Con fondo in rovere tinto moka e portaspezie in lamiera verniciata nero
With mocha-stained oak bottom and black painted sheet metal spice rack
Avec fond en chêne teinté moka et porte-épices en métal peinte en noir
Con base de roble teñido acabado moka y especiero de aluminio color negro
Mit mokkagebeiztem Eiche Boden und schwarz lackiertem Gewürzregal

P/D	L/W	H/H	CODICE	PUNTI
50	14,3	4,2	KPP0000005MO	184

Fit Portaspezie barattoli vetro con coperchio V1V

Fit Glass jar spice rack with lid V1V
Fit porte-épices bocaux en verre avec couvercle V1V
Fit especiero de cristal con tapa V1V
Fit Glas Gewürzglashalter mit Deckel V1V



Con fondo in rovere tinto moka e divisori in alluminio anodizzato nero
With mocha-stained oak bottom and black anodized aluminum dividers
Avec fond en chêne teinté moka et séparateurs en aluminium anodisé noir
Con fondo en roble teñido acabado moka y divisorios de aluminio anodizado negro
Mit mokkagebeiztem Eichenholz und schwarz eloxierten Aluminiumtrennwänden

P/D	L/W	H/H	CODICE	PUNTI
50	14,3	5,6	KPP0000006MO	154

Basi con maniglia
Base units with handle

Basi con gola
Base units with groove

Colonne
Tall units

Pensili
Wall units

Elementi speciali
Special elements

Maniglie gole zoccoli
Handles grooves plinth

Illuminazione
Lighting

Accessori
Accessories

Componenti e meccanismi
Components e mechanism

INSERTI PORTAPOSATE

Cutlery inserts
Insert porte-couverts
Insertos para cubiertos
Besteckhalter Einsätze

LINEA FIT

Fit Portaspezie barattoli vetro coperchio nero V1N

Fit Spice rack jars glass lid black V1N
Fit porte-épices bocaux en verre couvercle noir V1N
Fit especiero de cristal con tapa negra V1N
Fit Glas Gewürzglashalter mit Deckel schwarz V1N



Con fondo in rovere tinto moka e divisori in alluminio anodizzato nero
With mocha-stained oak bottom and black anodized aluminum dividers
Avec fond en chêne teinté moka et séparateurs en aluminium anodisé noir
Con fondo en roble teñido acabado moka y divisorios de aluminio anodizado negro
Mit mokkagebeiztem Eichenholz und schwarz eloxierten Aluminiumtrennwänden

P/D	L/W	H/H	CODICE	PUNTI
50	14,3	7,2	KPP0000007MO	174

Fit Set pasta fresca con accessori V1N

Fit Fresh pasta set with accessories V1N
Fit Set de pâtes fraîches avec accessoires V1N
Fit juego para pasta con accesorios V1N
Fit Fresh Nudelset mit Zubehör V1N



Con fondo in rovere tinto moka e divisori in alluminio anodizzato nero
With mocha-stained oak bottom and black anodized aluminum dividers
Avec fond en chêne teinté moka et séparateurs en aluminium anodisé noir
Con fondo en roble teñido acabado moka y divisorios de aluminio anodizado negro
Mit mokkagebeiztem Eichenholz und schwarz eloxierten Aluminiumtrennwänden

P/D	L/W	H/H	CODICE	PUNTI
50	14,3	4,2	KPP0000008MO	186

Fit Portaspezie barattoli vetro coperchio nero V2

Fit Spice rack jars glass lid black V2
Fit porte-épices bocaux en verre couvercle noir V2
Fit especieros de cristal con tapa negra V2
Fit Glas Gewürzglashalter mit Deckel schwarz V2



Con fondo e divisori in rovere tinto moka
With mocha-stained oak bottom and dividers
Avec fond et séparations en chêne teinté moka
Con fondo y divisorios en roble teñido acabado moka
Mit Boden und Trennwänden aus mokkagebeizter Eiche

P/D	CODICE	PUNTI
50	KPP0000014MO	159

INSERTI PORTAPOSATE

Cutlery inserts
Insert porte-couverts
Insertos para cubiertos
Besteckhalter Einsätze

LINEA FIT

Fit Portaspezie barattoli vetro coperchio V2

Fit Spice rack jars glass lid V2
Fit porte-épices bocaux en verre couvercle V2
Fit especieros de cristal con tapa V2
Fit Glas Gewürzglashalter mit Glasdeckel V2



Con fondo e divisori in rovere tinto moka
With mocha-stained oak bottom and dividers
Avec fond et séparations en chêne teinté moka
Con fondo y divisorios en roble teñido acabado moka
Mit Boden und Trennwänden aus mokkagebeizter Eiche

P/D	CODICE	PUNTI
50	KPP0000015MO	154

Basi con maniglia
Base units with handle

Basi con gola
Base units with groove

Colonne
Tall units

Pensili
Wall units

Elementi speciali
Special elements

Maniglie gole zoccoli
Handles grooves plinth

Illuminazione
Lighting

Accessori
Accessories

Componenti e meccanismi
Components e mechanism

Fit Set condimenti con accessori V2

Fit Condiment Set with Accessories V2
Fit Set de condiments avec accessoires V2
Fit juego para condimentos con accesorios V2
Fit Gewürzset mit Zubehör V2



Con fondo in rovere tinto moka e portacondimenti in lamiera verniciata nero
With mocha-stained oak bottom and black painted sheet metal rack
Avec fond en chêne teinté moka et porte-condiments en métal peinte en noir
Con base de roble teñido acabado moka y portacondimentos pintado de negro
Mit mokkagebeiztem Eichenboden und schwarz lackiertem Blechgestell

P/D	CODICE	PUNTI
50	KPP0000016MO	352

Fit Set vino con accessori V2

Fit Wine Set with accessories V2
Fit set à vin avec accessoires V2
Fit juego para vino con accesorios V2
Fit Wine Set mit Zubehör V2



Con fondo in rovere tinto moka e portaccessori in lamiera verniciata nero
With mocha-stained oak bottom and black painted sheet metal accessory holder
Avec fond en chêne teinté moka et porte-accessoires en métal peinte en noir
Con base de roble teñido acabado mokay portaplatos pintado de negro
Mit Boden aus mokkagebeizter Eiche und schwarz lackiertem Tellerhalter für Zubehör

P/D	CODICE	PUNTI
50	KPP0000017MO	336

INSERTI PORTAPOSATE

Cutlery inserts
Insert porte-couverts
Insertos para cubiertos
Besteckhalter Einsätze

LINEA FIT

Fit Set cocktail con accessori V2

Fit Cocktail Set with V2 accessories
Fit Set de cocktail avec accessoires V2
Fit juego para cocktail con accesorios V2
Fit Cocktail Set mit Zubehör V2



Con fondo in rovere tinto moka e portaccessori in lamiera verniciata nero
With mocha-stained oak bottom and black painted sheet metal accessory holder
Avec fond en chêne teinté moka et porte-accessoires en métal peinte en noir
Con base de roble teñido acabado mokay portaplatos pintado de negro
Mit Boden aus mokkagebeizter Eiche und schwarz lackiertem Tellerhalter für Zubehör

P/D	CODICE	PUNTI
50	KPP0000018MO	361

ACCESSORI DISPENSA

Pantry accessories
Accessoires pour le garde-manger
Accesorios para despensa
Zubehör für die Schränke

LINEA FIT

Fit Dispensa L. 60 V1

Fit Dispensa W. 60 V1
Fit garde-manger L.60 V1
Fit Almacenamiento A.60 V1
Fit Hochschrank B.60 V1

Con fondo in rovere tinto moka e guarnizioni antiscivolo

With mocha-stained oak bottom and non-slip seals
Avec fond en chêne teinté moka et joints antidérapants
Con base de roble teñido acabado moka y juntas antideslizantes
Mit mokkagebeiztem Eichenholzboden und rutschfesten Dichtungen

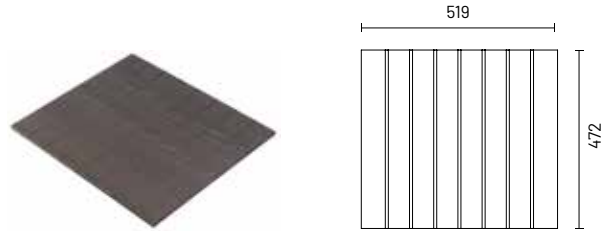

P/D	L/W	H/H	CODICE	PUNTI
50	60	1,4	KPP0406050M0	143
60	60	1,4	KPP0406060M0	291

■ **profondità 60 composta da elemento profondità 50 cm più compensatore** | depth 60 composed of element depth 50 cm plus compensator | profondeur 60 comprenant l'élément profondeur 50 cm plus compensateur | profundidad 60 constituida por un elemento profundidad 50 cm más compensador | tiefe 60 mit Elementtiefe 50 cm plus Kompensator

Fit Dispensa Porta piatti con pioli laterali L. 60 V3

Fit Larder unit with side pegs W. 60 V3
Fit porte-assiettes avec des chevilles latérales L.60 V3
Fit almacenamiento para platos con soportes laterales A.60 V3
Fit Hochschrank mit Tellerträger Stiften B.60 V3

Con fondo in rovere tinto moka
With mocha-stained oak bottom
Avec base en chêne teinté moka
Con base de roble teñido acabado moka
Mit Boden aus mokkagebeizter Eiche

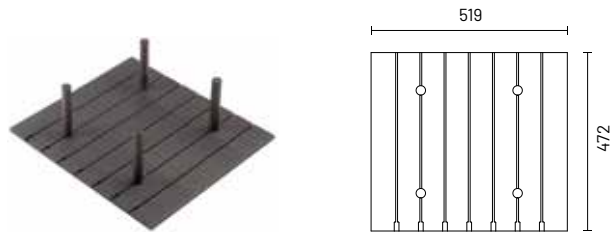

P/D	L/W	H/H	CODICE	PUNTI
50	60	17,3	KPP0606050M0	198
60	60	17,3	KPP0606060M0	345

■ **profondità 60 composta da elemento profondità 50 cm più compensatore** | depth 60 composed of element depth 50 cm plus compensator | profondeur 60 comprenant l'élément profondeur 50 cm plus compensateur | profundidad 60 constituida por un elemento profundidad 50 cm más compensador | tiefe 60 mit Elementtiefe 50 cm plus Kompensator

Fit Dispensa Divisorio croce L. 60 V5

Fit Dispensa Divider Cross W. 60 V5
Fit séparateurs croix L.60 V5
Fit Almacenamiento Divisorio Cross A.60 V5
Fit Hochschrank Teiler Kreuz B.60 V5

Con fondo e divisori in rovere tinto moka
With mocha-stained oak bottom and dividers
Avec fond et séparations en chêne teinté moka
Con fondo y divisorios en roble teñido acabado moka
Mit Boden und Trennwänden aus mokkagebeizter Eiche

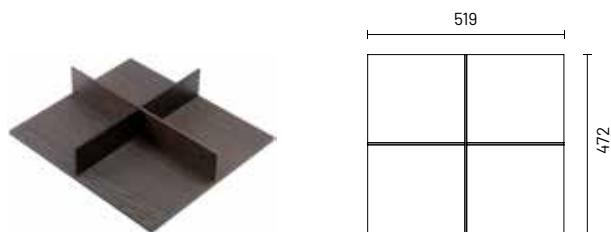

P/D	L/W	H/H	CODICE	PUNTI
50	60	10,2	KPP0806050M0	162
60	60	10,2	KPP0806060M0	309

■ **profondità 60 composta da elemento profondità 50 cm più compensatore** | depth 60 composed of element depth 50 cm plus compensator | profondeur 60 comprenant l'élément profondeur 50 cm plus compensateur | profundidad 60 constituida por un elemento profundidad 50 cm más compensador | tiefe 60 mit Elementtiefe 50 cm plus Kompensator

Basi con maniglia
Base units with handle

Basi con gola
Base units with groove

Colonne
Tall units

Pensili
Wall units

Elementi speciali
Special elements

Maniglie gole zoccoli
Handles grooves plinth

Illuminazione
Lighting

Accessori
Accessories

Componenti e meccanismi
Components e mechanism

ACCESSORI DISPENSA

Pantry accessories
Accessoires pour le garde-manger
Accesorios para despensa
Zubehör für die Schränke

LINEA FIT

Fit Dispensa barattoli vetro L. 60 V6

Fit Dispensa glass jars W. 60 V6
Fit bocaux en verre L.60 V6
Fit Almacenamiento vasos cristal A.60 V6
Passend zu den Dispensa-Glasgefäßen B.60 V6

Con fondo e divisori in rovere tinto moka
With mocha-stained oak bottom and dividers
Avec fond et séparations en chêne teinté moka
Con fondo y divisorios en roble teñido acabado moka
Mit Boden und Trennwänden aus mokkagebeizter Eiche

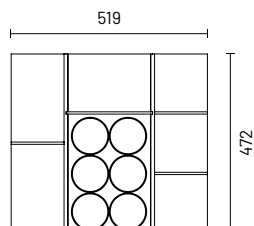

P/D	L/W	H/H	CODICE	PUNTI
50	60	16,3	KPP0906050MO	392
60	60	16,3	KPP0906060MO	540

■ **profondità 60 composta da elemento profondità 50 cm più compensatore** | depth 60 composed of element depth 50 cm plus compensator | profondeur 60 comprenant l'élément profondeur 50 cm plus compensateur | profundidad 60 constituida por un elemento profundidad 50 cm más compensador | tiefe 60 mit Elementtiefe 50 cm plus Kompensator

Fit Dispensa Portapentole Portacoperchi L. 60 V7

Fit Pantry Rack W. 60 V7
Fit porte-casserolles/couvercles L.60 V7
Fit almacenamiento para ollas-tapas A.60 V7
Fit Hochschrank mit Topf/dekelhalter B.60 V7

Con fondo in rovere tinto moka e portacoperchi in alluminio anodizzato nero con spazzole e guarnizioni antiscivolo
With mocha-stained oak bottom and black anodized aluminum lid holders with non-slip brushes and seals
Avec fond en chêne teinté moka et porte-couvercle en aluminium anodisé noir avec brosses et joints antidérapants
Con base de roble teñido color moka y soporte para tapas de aluminio anodizado negro con cepillos y juntas antideslizantes
Mit mokkagebeiztem Eichenholzboden und schwarz eloxiertem Aluminium-Deckelhalter mit Bürsten und rutschfesten Dichtungen

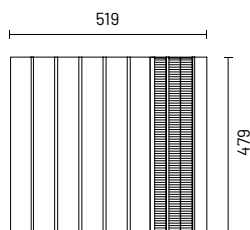

P/D	L/W	H/H	CODICE	PUNTI
50	60	10,2	KPP1006050MO	311
60	60	10,2	KPP1006060MO	458

■ **profondità 60 composta da elemento profondità 50 cm più compensatore** | depth 60 composed of element depth 50 cm plus compensator | profondeur 60 comprenant l'élément profondeur 50 cm plus compensateur | profundidad 60 constituida por un elemento profundidad 50 cm más compensador | tiefe 60 mit Elementtiefe 50 cm plus Kompensator

Fit Dispensa L. 75 V1

Fit Dispensa W. 75 V1
Fit garde-manger L.75 V1
Fit almacenamiento A.75 V1
Fit Hochschrank B.75 V1

Con fondo in rovere tinto moka e guarnizioni antiscivolo
With mocha-stained oak bottom and non-slip seals
Avec fond en chêne teinté moka et joints antidérapants
Con base de roble teñido acabado moka y juntas antideslizantes
Mit mokkagebeiztem Eichenholzboden und rutschfesten Dichtungen

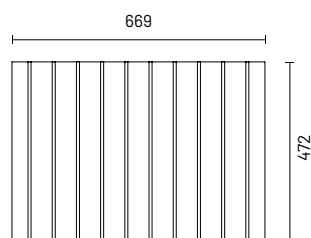

P/D	L/W	H/H	CODICE	PUNTI
50	75	1,4	KPP0407550MO	211
60	75	1,4	KPP0407560MO	366

■ **profondità 60 composta da elemento profondità 50 cm più compensatore** | depth 60 composed of element depth 50 cm plus compensator | profondeur 60 comprenant l'élément profondeur 50 cm plus compensateur | profundidad 60 constituida por un elemento profundidad 50 cm más compensador | tiefe 60 mit Elementtiefe 50 cm plus Kompensator

ACCESSORI DISPENSA

Pantry accessories
Accessoires pour le garde-manger
Accesorios para despensa
Zubehör für die Schränke

LINEA FIT

Fit Dispensa Portapentole con divisori laterali L. 75 V2

Fit Pantry unit with side dividers W. 75 V2
Fit porte-casserroles avec séparateurs latéraux L.75 V2
Fit almacenamiento para ollas con divisorios laterales A.75 V2
Fit Hochschrank mit Topfhalter mit Seitenteilern L.75 V2

Con fondo e divisori in rovere tinto moka con guarnizioni antiscivolo

With mocha-stained oak bottom and dividers with non-slip seals
Avec fond et séparations en chêne teinté moka avec joints antidérapants
Con fondo y divisorios en roble teñido acabado moka con juntas antideslizantes
Mit rutschfesten Boden und Trennwänden aus mokkagebeizter Eiche

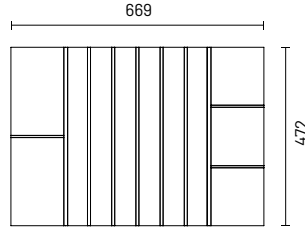

P/D	L/W	H/H	CODICE	PUNTI
50	75	10,2	KPP0507550MO	326
60	75	10,2	KPP0507560MO	482

■ **profondità 60 composta da elemento profondità 50 cm più compensatore** | depth 60 composed of element depth 50 cm plus compensator | profondeur 60 comprenant l'élément profondeur 50 cm plus compensateur |
profundidad 60 constituida por un elemento profundidad 50 cm más compensador | tiefe 60 mit Elementtiefe 50 cm plus Kompensator

Fit Dispensa Porta piatti con pioli laterali L. 75 V3

Fit Larder unit with side pegs W. 75 V3
Fit porte-assiettes avec des chevilles latérales L.75 V3
Fit almacenamiento para platos con soportes laterales A.75 V3
Fit Hochschrank mit Tellerträger Stiften B.75 V3

Con fondo in rovere tinto moka

With mocha-stained oak bottom
Avec base en chêne teinté moka
Con base de roble teñido acabado moka
Mit Boden aus mokkagebeizter Eiche

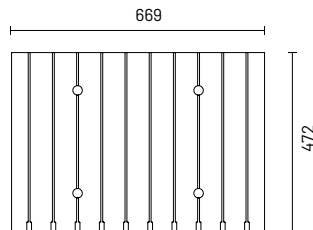

P/D	L/W	H/H	CODICE	PUNTI
50	75	17,3	KPP0607550MO	327
60	75	17,3	KPP0607560MO	483

■ **profondità 60 composta da elemento profondità 50 cm più compensatore** | depth 60 composed of element depth 50 cm plus compensator | profondeur 60 comprenant l'élément profondeur 50 cm plus compensateur |
profundidad 60 constituida por un elemento profundidad 50 cm más compensador | tiefe 60 mit Elementtiefe 50 cm plus Kompensator

Fit Dispensa Porta piatti con divisori laterali L. 75 V4

Fit Larder unit with side dividers W. 75 V4
Fit porte-assiettes avec séparateurs latéraux L.75 V4
Fit almacenamiento para platos con divisorios laterales A.75 V4
Fit Hochschrank mit Tellerträger mit Seitenteilern L.75 V4

Con fondo, divisori e pioli in rovere tinto moka

With bottom, dividers and pegs in mocha-stained oak
Avec socle, séparateurs et chevilles en chêne teinté moka
Con base, divisorios y clavijas de roble teñido color moka
Mit Boden, Trennwänden und Wäscheclammern aus mokkagebeizter Eiche

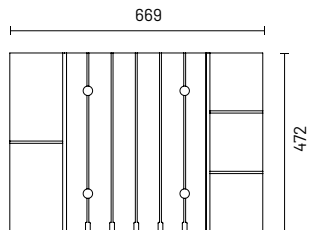

P/D	L/W	H/H	CODICE	PUNTI
50	75	17,3	KPP0707550MO	393
60	75	17,3	KPP0707560MO	549

■ **profondità 60 composta da elemento profondità 50 cm più compensatore** | depth 60 composed of element depth 50 cm plus compensator | profondeur 60 comprenant l'élément profondeur 50 cm plus compensateur |
profundidad 60 constituida por un elemento profundidad 50 cm más compensador | tiefe 60 mit Elementtiefe 50 cm plus Kompensator

Basi con maniglia
Base units with handle

Basi con gola
Base units with groove

Colonne
Tall units

Pensili
Wall units

Elementi speciali
Special elements

Maniglie gole zoccoli
Handles grooves plinth

Illuminazione
Lighting

Accessori
Accessories

Componenti e meccanismi
Components e mechanism

ACCESSORI DISPENSA

Pantry accessories
Accessoires pour le garde-manger
Accesorios para despensa
Zubehör für die Schränke

LINEA FIT

Fit Dispensa Portapentole Portacoperchi L. 75 V7

Fit Pantry Rack W. 75 V7

Fit porte-casserolles/couvercles L.75 V7

Fit almacenamiento para ollas-tapas A.75 V7

Fit Hochschrank mit Topf/dekelhalter B.75 V7

Con fondo in rovere tinto moka e portacoperchi in alluminio anodizzato nero con spazzole e guarnizioni antiscivolo
With mocha-stained oak bottom and black anodized aluminum lid holders with non-slip brushes and seals
Avec fond en chêne teinté moka et porte-couvercle en aluminium anodisé noir avec brosses et joints antidérapants
Con base de roble teñido color moka y soporte para tapas de aluminio anodizado negro con cepillos y juntas antideslizantes
Mit mokkagebeiztem Eichenholzboden und schwarz eloxiertem Aluminium-Deckelhalter mit Bürsten und rutschfesten Dichtungen

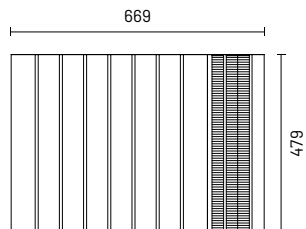

P/D	L/W	H/H	CODICE	PUNTI
50	75	10,2	KPP1007550MO	348
60	75	10,2	KPP1007560MO	503

■ **profondità 60 composta da elemento profondità 50 cm più compensatore** | depth 60 composed of element depth 50 cm plus compensator | profondeur 60 comprenant l'élément profondeur 50 cm plus compensateur | profundidad 60 constituida por un elemento profundidad 50 cm más compensador | tiefe 60 mit Elementtiefe 50 cm plus Kompensator

Fit Dispensa L. 90 V1

Fit Dispensa W. 90 V1

Fit garde-manger L.90 V1

Fit Almacenamiento A.90 V1

Fit Hochschrank B.90 V1

Con fondo in rovere tinto moka e guarnizioni antiscivolo
With mocha-stained oak bottom and non-slip seals
Avec fond en chêne teinté moka et joints antidérapants
Con base de roble teñido acabado moka y juntas antideslizantes
Mit mokkagebeiztem Eichenholzboden und rutschfesten Dichtungen

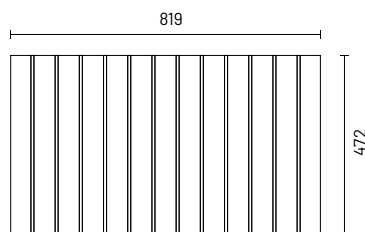

P/D	L/W	H/H	CODICE	PUNTI
50	90	1,4	KPP0409050MO	210
60	90	1,4	KPP0409060MO	373

■ **profondità 60 composta da elemento profondità 50 cm più compensatore** | depth 60 composed of element depth 50 cm plus compensator | profondeur 60 comprenant l'élément profondeur 50 cm plus compensateur | profundidad 60 constituida por un elemento profundidad 50 cm más compensador | tiefe 60 mit Elementtiefe 50 cm plus Kompensator

Fit Dispensa Portapentole con divisori laterali L. 90 V2

Fit Pantry unit with side dividers W. 90 V2

AmFit porte-casserolles avec séparateurs latéraux L.90 V2

Fit almacenamiento para ollas con divisorios laterales A.90 V2

Fit Hochschrank mit Topfhalter mit seitlichen Trennwänden L.90 V2

Con fondo e divisori in rovere tinto moka con guarnizioni antiscivolo
With mocha-stained oak bottom and dividers with non-slip seals
Avec fond et séparations en chêne teinté moka avec joints antidérapants
Con fondo y divisorios en roble teñido acabado moka con juntas antideslizantes
Mit rutschfesten Boden und Trennwänden aus mokkagebeizter Eiche

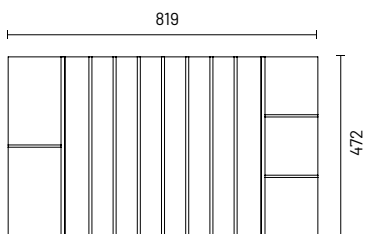

P/D	L/W	H/H	CODICE	PUNTI
50	90	10,2	KPP0509050MO	345
60	90	10,2	KPP0509060MO	508

■ **profondità 60 composta da elemento profondità 50 cm più compensatore** | depth 60 composed of element depth 50 cm plus compensator | profondeur 60 comprenant l'élément profondeur 50 cm plus compensateur | profundidad 60 constituida por un elemento profundidad 50 cm más compensador | tiefe 60 mit Elementtiefe 50 cm plus Kompensator

ACCESSORI DISPENSA

Pantry accessories
Accessoires pour le garde-manger
Accesorios para despensa
Zubehör für die Schränke

LINEA FIT

Fit Dispensa Porta piatti con pioli laterali L. 90 V3

Fit Larder unit with side pegs W. 90 V3
Fit porte-assiettes avec des chevilles latérales L.90 V3
Fit almacenamiento para platos con soportes laterales A.90 V3
Fit Hochschrank mit Tellerträger Stiften B.90 V3

Con fondo in rovere tinto moka
With mocha-stained oak bottom
Avec base en chêne teinté moka
Con base de roble teñido acabado moka
Mit Boden aus mokkagebeizter Eiche

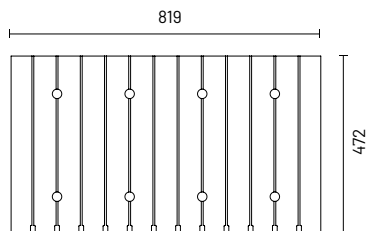

P/D	L/W	H/H	CODICE	PUNTI
50	90	17,3	KPP0609050M0	327
■ 60	90	17,3	KPP0609060M0	490

■ **profondità 60 composta da elemento profondità 50 cm più compensatore** | depth 60 composed of element depth 50 cm plus compensator | profondeur 60 comprenant l'élément profondeur 50 cm plus compensateur |
profundidad 60 constituida por un elemento profundidad 50 cm más compensador | tiefe 60 mit Elementtiefe 50 cm plus Kompensator

Fit Dispensa Porta piatti con divisori laterali L. 90 V4

Fit Larder unit with side dividers W. 90 V4
Fit porte-assiettes avec séparateurs latéraux L.90 V4
Fit almacenamiento para platos con divisorios laterales A.90 V4
Fit Hochschrank mit Tellerträger mit Seitenteilern L.90 V4

Con fondo, divisori e pioli in rovere tinto moka
With bottom, dividers and pegs in mocha-stained oak
Avec socle, séparateurs et chevilles en chêne teinté moka
Con base, divisorios y clavijas de roble teñido color moka
Mit Boden, Trennwänden und Wäscheklammern aus mokkagebeizter Eiche

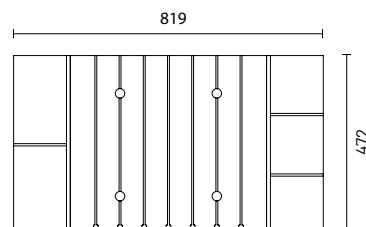

P/D	L/W	H/H	CODICE	PUNTI
50	90	17,3	KPP0709050M0	407
■ 60	90	17,3	KPP0709060M0	570

■ **profondità 60 composta da elemento profondità 50 cm più compensatore** | depth 60 composed of element depth 50 cm plus compensator | profondeur 60 comprenant l'élément profondeur 50 cm plus compensateur |
profundidad 60 constituida por un elemento profundidad 50 cm más compensador | tiefe 60 mit Elementtiefe 50 cm plus Kompensator

Fit Dispensa Divisorio croce L. 90 V5

Fit Dispensa Divider cross W. 90 V5
Fit séparateurs croix L.90 V5
Fit Almacenamiento Divisorio cross A.90 V5
Fit Hochschrank Teilerkreuz B.90 V5

Con fondo e divisori in rovere tinto moka
With mocha-stained oak bottom and dividers
Avec fond et séparations en chêne teinté moka
Con fondo y divisorios en roble teñido acabado moka
Mit Boden und Trennwänden aus mokkagebeizter Eiche

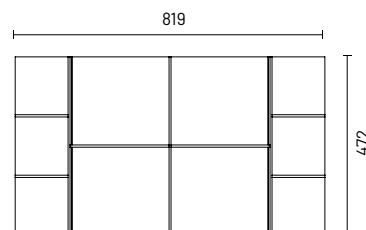

P/D	L/W	H/H	CODICE	PUNTI
50	90	10,2	KPP0809050M0	371
■ 60	90	10,2	KPP0809060M0	534

■ **profondità 60 composta da elemento profondità 50 cm più compensatore** | depth 60 composed of element depth 50 cm plus compensator | profondeur 60 comprenant l'élément profondeur 50 cm plus compensateur |
profundidad 60 constituida por un elemento profundidad 50 cm más compensador | tiefe 60 mit Elementtiefe 50 cm plus Kompensator

Basi con maniglia
Base units with handle

Basi con gola
Base units with groove

Colonne
Tall units

Pensili
Wall units

Elementi speciali
Special elements

Maniglie gole zoccoli
Handles grooves plinth

Illuminazione
Lighting

Accessori
Accessories

Componenti e meccanismi
Components e mechanism

ACCESSORI DISPENSA

Pantry accessories
Accessoires pour le garde-manger
Accesorios para despensa
Zubehör für die Schränke

LINEA FIT

Fit Dispensa Portapentole Portacoperchi L. 90 V7

Fit Pantry Rack W. 90 V7
Fit porte-casserolles/couvercles L.90 V7
Fit almacenamiento para ollas-tapas A.90 V7
Fit Hochschrank mit Topf/dekelhalter B.90 V7

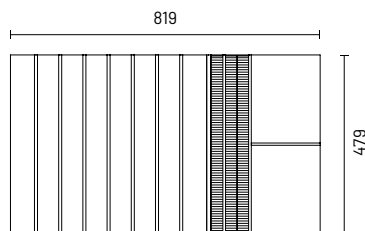

Con fondo in rovere tinto moka e portacoperchi in alluminio anodizzato nero con spazzole e guarnizioni antiscivolo
With mocha-stained oak bottom and black anodized aluminum lid holders with non-slip brushes and seals
Avec fond en chêne teinté moka et porte-couvercle en aluminium anodisé noir avec brosses et joints antidérapants
Con base de roble teñido color moka y soporte para tapas de aluminio anodizado negro con cepillos y juntas antideslizantes
Mit mokkagebeiztem Eichenholzboden und schwarz eloxiertem Aluminium-Deckelhalter mit Bürsten und rutschfesten Dichtungen

P/D	L/W	H/H	CODICE	PUNTI
50	90	10,2	KPP1009050MO	396
■ 60	90	10,2	KPP1009060MO	559

■ **profondità 60 composta da elemento profondità 50 cm più compensatore** | depth 60 composed of element depth 50 cm plus compensator | profondeur 60 comprenant l'élément profondeur 50 cm plus compensateur | profundidad 60 constituida por un elemento profundidad 50 cm más compensador | tiefe 60 mit Elementtiefe 50 cm plus Kompensator

Fit Dispensa Portapentole con divisori laterali L. 105 V2

Fit Pantry unit with side dividers W. 105 V2
Fit porte-casserolles avec séparateurs latéraux L.105 V2
Fit almacenamiento para ollas con divisorios laterales A.105 V2
Fit Hochschrank mit Topfhalter mit Seitenteilern L.105 V2

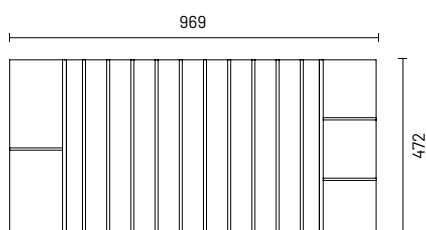

Con fondo e divisori in rovere tinto moka con guarnizioni antiscivolo
With mocha-stained oak bottom and dividers with non-slip seals
Avec fond et séparations en chêne teinté moka avec joints antidérapants
Con fondo y divisorios en roble teñido acabado moka con juntas antideslizantes
Mit rutschfesten Boden und Trennwänden aus mokkagebeizter Eiche

P/D	L/W	H/H	CODICE	PUNTI
50	105	10,2	KPP0510550MO	414
■ 60	105	10,2	KPP0510560MO	583

■ **profondità 60 composta da elemento profondità 50 cm più compensatore** | depth 60 composed of element depth 50 cm plus compensator | profondeur 60 comprenant l'élément profondeur 50 cm plus compensateur | profundidad 60 constituida por un elemento profundidad 50 cm más compensador | tiefe 60 mit Elementtiefe 50 cm plus Kompensator

Fit Dispensa Porta piatti con divisori laterali L. 105 V4

Fit Larder unit with side dividers W. 105 V4
Fit porte-assiettes avec séparateurs latéraux L.105 V4
Fit almacenamiento para platos con divisorios laterales A.105 V4
Fit Hochschrank mit Tellerträger mit Seitenteilern L.105 V4

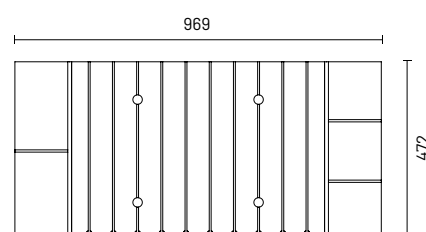

Con fondo, divisori e pioli in rovere tinto moka
With bottom, dividers and pegs in mocha-stained oak
Avec socle, séparateurs et chevilles en chêne teinté moka
Con base, divisorios y clavijas de roble teñido color moka
Mit Boden, Trennwänden und Wäscheklammern aus mokkagebeizter Eiche

P/D	L/W	H/H	CODICE	PUNTI
50	105	17,3	KPP0710550MO	539
■ 60	105	17,3	KPP0710560MO	708

■ **profondità 60 composta da elemento profondità 50 cm più compensatore** | depth 60 composed of element depth 50 cm plus compensator | profondeur 60 comprenant l'élément profondeur 50 cm plus compensateur | profundidad 60 constituida por un elemento profundidad 50 cm más compensador | tiefe 60 mit Elementtiefe 50 cm plus Kompensator

ACCESSORI DISPENSA

Pantry accessories
Accessoires pour le garde-manger
Accesorios para despensa
Zubehör für die Schränke

LINEA FIT

Fit Dispensa Portapentole Portacoperchi L. 105 V7

Fit Pantry Rack W. 105 V7
Fit porte-casseroles/couvercles L.105 V7
Fit almacenamiento para ollas-tapas A.105 V7
Fit Hochschrank mit Topf/dekelhalter B.105 V7

Con fondo in rovere tinto moka e portacoperchi in alluminio anodizzato nero con spazzole e guarnizioni antiscivolo
With mocha-stained oak bottom and black anodized aluminum lid holders with non-slip brushes and seals
Avec fond en chêne teinté moka et porte-couvercle en aluminium anodisé noir avec brosses et joints antidérapants
Con base de roble teñido color moka y soporte para tapas de aluminio anodizado negro con cepillos y juntas antideslizantes
Mit mokkagebeiztem Eichenholzboden und schwarz eloxiertem Aluminium-Deckelhalter mit Bürsten und rutschfesten Dichtungen

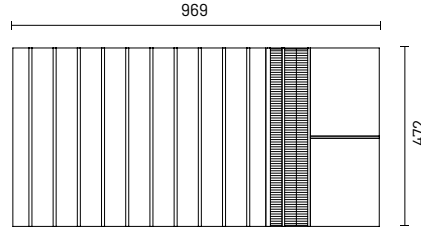

P/D	L/W	H/H	CODICE	PUNTI
50	105	10,2	KPP1010550MO	428
■ 60	105	10,2	KPP1010560MO	597

■ **profondità 60 composta da elemento profondità 50 cm più compensatore** | depth 60 composed of element depth 50 cm plus compensator | profondeur 60 comprenant l'élément profondeur 50 cm plus compensateur |
profundidad 60 constituida por un elemento profundidad 50 cm más compensador | tiefe 60 mit Elementtiefe 50 cm plus Kompensator

Fit Dispensa Portapentole con divisori laterali L. 120 V2

Fit Pantry unit with side dividers W. 120 V2
Fit porte-casseroles avec séparateurs latéraux L.120 V2
Fit almacenamiento para ollas con divisorios laterales A.120 V2
Fit Hochschrank mit Topfhalter mit Seitenteilern L.120 V2

Con fondo e divisori in rovere tinto moka con guarnizioni antiscivolo
With mocha-stained oak bottom and dividers with non-slip seals
Avec fond et séparations en chêne teinté moka avec joints antidérapants
Con fondo y divisorios en roble teñido acabado moka con juntas antideslizantes
Mit rutschfesten Boden und Trennwänden aus mokkagebeizter Eiche

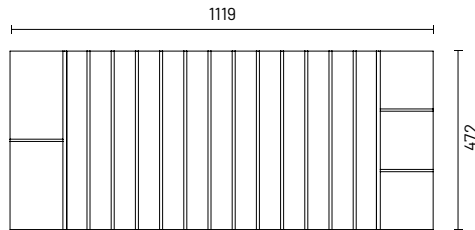

P/D	L/W	H/H	CODICE	PUNTI
50	120	10,2	KPP0512050MO	539
■ 60	120	10,2	KPP0512060MO	717

■ **profondità 60 composta da elemento profondità 50 cm più compensatore** | depth 60 composed of element depth 50 cm plus compensator | profondeur 60 comprenant l'élément profondeur 50 cm plus compensateur |
profundidad 60 constituida por un elemento profundidad 50 cm más compensador | tiefe 60 mit Elementtiefe 50 cm plus Kompensator

Fit Dispensa Porta piatti con divisori laterali L. 120 V4

Fit Larder unit with side dividers W. 120 V4
Fit porte-assiettes avec séparateurs latéraux L.120 V4
Fit almacenamiento para platos con divisorios laterales A.120 V4
Fit Hochschrank mit Tellerträger mit seitlichen Trennwänden L.120 V4

Con fondo, divisori e pioli in rovere tinto moka
With bottom, dividers and pegs in mocha-stained oak
Avec socle, séparateurs et chevilles en chêne teinté moka
Con base, divisorios y clavijas de roble teñido color moka
Mit Boden, Trennwänden und Wäscheklammern aus mokkagebeizter Eiche

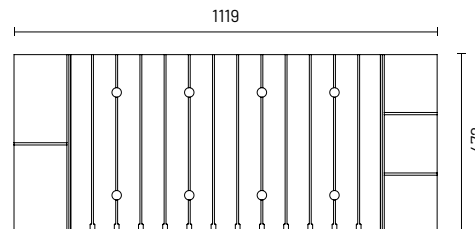

P/D	L/W	H/H	CODICE	PUNTI
50	120	17,3	KPP0712050MO	539
■ 60	120	17,3	KPP0712060MO	717

■ **profondità 60 composta da elemento profondità 50 cm più compensatore** | depth 60 composed of element depth 50 cm plus compensator | profondeur 60 comprenant l'élément profondeur 50 cm plus compensateur |
profundidad 60 constituida por un elemento profundidad 50 cm más compensador | tiefe 60 mit Elementtiefe 50 cm plus Kompensator

Basi con maniglia
Base units with handle

Basi con gola
Base units with groove

Colonne
Tall units

Pensili
Wall units

Elementi speciali
Special elements

Maniglie gole zoccoli
Handles grooves plinth

Illuminazione
Lighting

Accessori
Accessories

Componenti e meccanismi
Components e mechanism

ACCESSORI DISPENSA

Pantry accessories
Accessoires pour le garde-manger
Accesorios para despensa
Zubehör für die Schränke

LINEA FIT

Fit Dispensa Divisorio croce L. 120 V5

Fit Dispensa Divider Cross W. 120 V5
Fit séparateurscroixL.120 V5
Fit Almacenamiento Divisorio Cross A.120 V5
Fit Hochschrank Teiler Kreuz B.120 V5

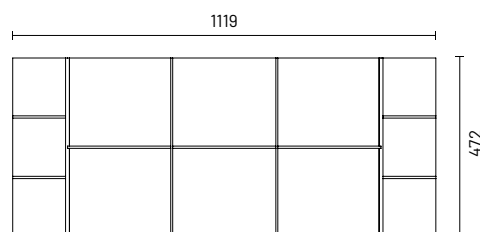
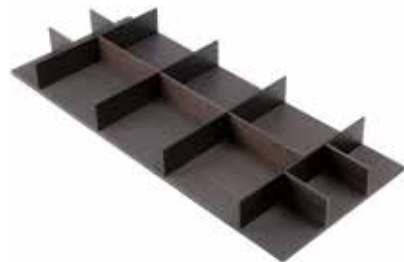

Con fondo e divisori in rovere tinto moka
With mocha-stained oak bottom and dividers
Avec fond et séparations en chêne teinté moka
Con fondo y divisorios en roble teñido acabado moka
Mit Boden und Trennwänden aus mokkagebeizter Eiche

P/D	L/W	H/H	CODICE	PUNTI
50	120	10,2	KPP0812050MO	468
■ 60	120	10,2	KPP0812060MO	646

■ **profondità 60 composta da elemento profondità 50 cm più compensatore** | depth 60 composed of element depth 50 cm plus compensator | profondeur 60 comprenant l'élément profondeur 50 cm plus compensateur | profundidad 60 constituida por un elemento profundidad 50 cm más compensador | tiefe 60 mit Elementtiefe 50 cm plus Kompensator

Fit Dispensa Portapentole Portacoperchi L. 120 V7

Fit Pantry Rack W. 120 V7
Fit porte-casserolles/couvercles L.120 V7
Fit almacenamiento para ollas-tapas A.120 V7
Fit Hochschrank mit Topf/deckelhalter B.120 V7

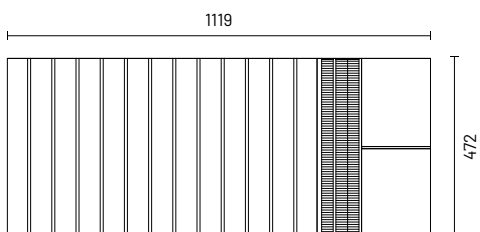

Con fondo in rovere tinto moka e portacoperchi in alluminio anodizzato nero con spazzole e guarnizioni antiscivolo
With mocha-stained oak bottom and black anodized aluminum lid holders with non-slip brushes and seals
Avec fond en chêne teinté moka et porte-couvercle en aluminium anodisé noir avec brosses et joints antidérapants
Con base de roble teñido color moka y soporte para tapas de aluminio anodizado negro con cepillos y juntas antideslizantes
Mit mokkagebeiztem Eichenholzboden und schwarz eloxiertem Aluminium-Deckelhalter mit Bürsten und rutschfesten Dichtungen

P/D	L/W	H/H	CODICE	PUNTI
50	120	10,2	KPP1012050MO	455
■ 60	120	10,2	KPP1012060MO	633

■ **profondità 60 composta da elemento profondità 50 cm più compensatore** | depth 60 composed of element depth 50 cm plus compensator | profondeur 60 comprenant l'élément profondeur 50 cm plus compensateur | profundidad 60 constituida por un elemento profundidad 50 cm más compensador | tiefe 60 mit Elementtiefe 50 cm plus Kompensator

INSERTI DISPENSA

Pantry inserts
Insert garde-manger
Insertos de despensa
Apothekerschrank-Einsätze

LINEA FIT

Fit Scatola porta accessori V2

Fit V2 accessory box
Fit boîte porte-accessoires V2
Fit caja para accesorios V2
Fit Zubehörbox V2



Con fondo, divisori e coperchio in rovere tinto moka
With bottom, dividers and lid in mocha-stained oak
Avec fond, séparateurs et couvercle en chêne teinté moka
Con fondo, divisorios y tapa de roble teñido acabado moka
Mit Boden, Trennwänden und Deckel aus mokkagebeizter Eiche

P/D	L/W	H/H	CODICE	PUNTI
50	26,6	9,6	KPP000009M0	312

Fit Scatola porta bottiglie V2

Fit V2 bottle box
Fit boîte porte-bouteilles V2
Fit caja para botellas V2
Fit Flaschenhalter V2



Con fondo e coperchio in rovere tinto moka
With mocha-stained oak bottom and lid
Avec fond et couvercle en chêne teinté moka
Con fondo y tapa en roble teñido acabado moka
Mit Boden und Deckel aus mokkagebeizter Eiche

P/D	L/W	H/H	CODICE	PUNTI
50	26,6	9,6	KPP000010M0	327

Fit Scatola porta bicchieri V2

Fit V2 Cup Holder Box
Fit boîte porte-verres V2
Fit caja para vasos V2
Fit Gläserbox V2



Con fondo e divisori in rovere tinto moka
With mocha-stained oak bottom and dividers
Avec fond et séparations en chêne teinté moka
Con fondo y divisorios en roble teñido acabado moka
Mit Boden und Trennwänden aus mokkagebeizter Eiche

P/D	L/W	H/H	CODICE	PUNTI
50	21	4,8	KPP000011M0	210

Basi con maniglia
Base units with handle

Basi con gola
Base units with groove

Colonne
Tall units

Pensili
Wall units

Elementi speciali
Special elements

Maniglie gole zoccoli
Handles grooves plinth

Illuminazione
Lighting

Accessori
Accessories

Componenti e meccanismi
Components e mechanism

INSERTI DISPENSA

Pantry inserts
Insert garde-manger
Insertos de despensa
Apothekerschrank-Einsätze

LINEA FIT

Fit Scatola porta piatti V2

Fit V2 plate box
Fit boîte porte-assiettes V2
Fit caja para platos V2
Fit Tellerträgerbox V2



Con fondo e coperchio in rovere tinto moka
With mocha-stained oak bottom and lid
Avec fond et couvercle en chêne teinté moka
Con fondo y tapa en roble teñido acabado moka
Mit Boden und Deckel aus mokka-beizter Eiche

P/D	L/W	H/H	CODICE	PUNTI
50	26,6	4,8	KPP0000012MO	392

Fit Scatola scolapiatti V2

Fit Dish drainer box V2
Fit boîte égouttoire V2
Fit caja escurridor V2
Fit Abtropfgestell Box V2



Con fondo in rovere tinto moka e scolapiatti in alluminio anodizzato
With mocha-stained oak bottom and anodized aluminum dish rack
Avec fond en chêne teinté moka et porte-vaisselle en aluminium anodisé
Con base de roble teñido acabado moka y escurridor de aluminio anodizado
Mit Boden aus mokka-beizter Eiche und Geschirrschubkast aus eloxiertem Aluminium

P/D	L/W	H/H	CODICE	PUNTI
50	26,6	4,8	KPP0000013MO	392

Fit tagliere double face V2

Fit double-sided cutting board V2
Fit planche à découper double face V2
Fit para tabla de cortar de doble cara V2
Passendes doppelseitiges Schneidebrett V2



Rovere naturale olio enologico
Natural oak oenological oil
Huile de chêne naturelle
Roble natural aceite enológico
Natürliches Eichenöl

P/D	L/W	H/H	CODICE	PUNTI
47,2	23,7	2,2	KPP0000019MO	472

ACCESSORI DISPENSA

Pantry accessories
Accessoires pour le garde-manger
Accesorios para despensa
Zubehör für die Schränke

LINEA FRAME



Telaio contenitore Frame Plus luce anteriore

Frame container frame Plus front light
Feu avant Frame Plus
Luz delantera Frame Plus con luz frontal
Frame Plus Frontleuchte

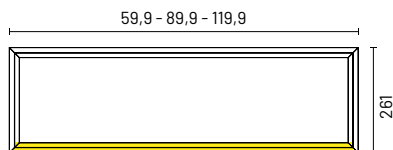

P/D	L/W	H/H	CODICE	PUNTI
26,1	90	5,1	KIF020902651A	392
26,1	120	5,1	KIF021202651A	452

Telaio contenitore Frame Plus luce posteriore

Frame container frame Plus rear light
Feu arrière du conteneur Frame Plus
Luz delantera Frame Plus con luz posterior
Frame Plus Containerrahmen Rücklicht

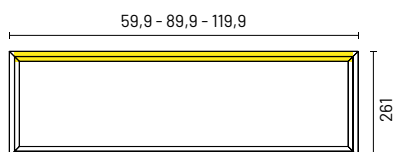

P/D	L/W	H/H	CODICE	PUNTI
26,1	90	5,1	KIF020902651P	392
26,1	120	5,1	KIF021202651P	452

Basi con maniglia
Base units with handle

Basi con gola
Base units with groove

Colonne
Tall units

Pensili
Wall units

Elementi speciali
Special elements

Maniglie gole zoccoli
Handles grooves plinth

Illuminazione
Lighting

Accessori
Accessories

Componenti e meccanismi
Components e mechanism

ACCESSORI DISPENSA

Pantry accessories
Accessoires pour le garde-manger
Accesorios para despensa
Zubehör für die Schränke

LINEA FRAME

Telaio contenitore Frame con luce anteriore

Frame container frame with front light
Cadre conteneur cadre avec lumière frontale
Marco contenedor Frame con luz frontal
Frame Containerrahmen mit Frontleuchte

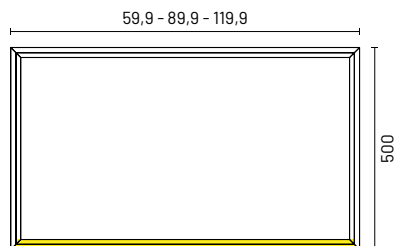

P/D	L/W	H/H	CODICE	PUNTI
50	60	5,1	KIF010605051A	360
50	90	5,1	KIF010905051A	416
50	120	5,1	KIF011205051A	471

Telaio contenitore Frame con luce posteriore

Frame container frame with back light
Châssis de conteneur avec feu arrière
Marco contenedor Frame con luz posterior
Frame Container mit Rücklicht

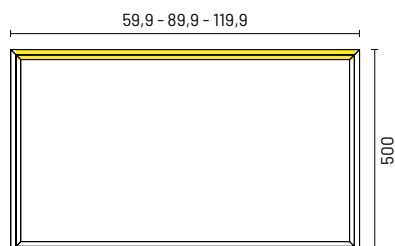

P/D	L/W	H/H	CODICE	PUNTI
50	60	5,1	KIF010605051P	360
50	90	5,1	KIF010905051P	416
50	120	5,1	KIF011205051P	471

INSERTI DISPENSA

Pantry inserts
Insert garde-manger
Insertos de despensa
Apothekerschrank-Einsätze

LINEA FRAME

Ripiano

Shelf
Étagère
Estante
Fachboden



P/D	L/W	CODICE	PUNTI
50	60	KACF10604748M	222
50	90	KACF10904748M	326
50	120	KACF11204748M	401

Porta bottiglie

Bottle holder
Porte-bouteille
Portabotellas
Flaschenhalter



P/D	L/W	CODICE	PUNTI
50	60	KACF20604748M	440
50	90	KACF20904748M	621
50	120	KACF21204748M	866

Porta calici

Goblet rack
Porte-verres
Portavasos
Glashalter



P/D	L/W	CODICE	PUNTI
50	60	KACF30604748M	248
50	90	KACF30904748M	348
50	120	KACF31204748M	421

Basi con maniglia
Base units with handle

Basi con gola
Base units with groove

Colonne
Tall units

Pensili
Wall units

Elementi speciali
Special elements

Maniglie gole zoccoli
Handles grooves plinth

Illuminazione
Lighting

Accessori
Accessories

Componenti e meccanismi
Components e mechanism

INSERTI DISPENSA

Pantry inserts
Insert garde-manger
Insertos de despensa
Apothekerschrank-Einsätze

LINEA FRAME

Plus Preprazione V1

Plus Prepraction V1
Plus Prepraction V1
Plus Prepraction V1
Plus Prepraction V1

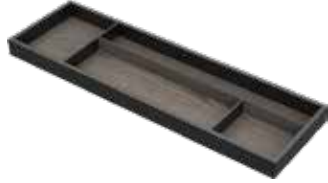

P/D	L/W	CODICE	PUNTI
26	90	KACF40902348M	524
26	120	KACF41202348M	552

Plus Preprazione V2

Plus Prepraction V2
Plus Prepraction V2
Plus Prepraction V2
Plus Prepraction V2



P/D	L/W	CODICE	PUNTI
26	90	KACF50902348M	524
26	120	KACF51202348M	552

ACCESSORI COLONNE RIENTRANTI

Accessories for pocket doors tall units
 Accessoires colonnes portes rentrantes
 Accesorios columnas retráctiles
 Zubehör versenkbare Schränke



Top con piano acciaio inox estraibile

Top with removable stainless steel top
 Plan travail en acier inoxydable extractible
 Encimera de acero inoxidable extraíble
 Deckel mit abnehmbarem Edelstahldeckel



P/D	L/W	H/H	CODICE	PUNTI
60	60	13,3	KWT010606013	1.911
60	90	133	KWT010906013	2.044
60	120	13,3	KWT011206013	2.181

Coppia staffe per fissaggio piano

Pair of brackets for plane fixing
 Paire de supports pour fixation plan travail
 Pareja de soportes para fijación sobre
 Beschläge für Arbeitsplatte Befestigung

CODICE	PUNTI
KWA000000001	91

Basi con maniglia
 Base units with handle

Basi con gola
 Base units with groove

Colonne
 Tall units

Pensili
 Wall units

Elementi speciali
 Special elements

Maniglie gole zoccoli
 Handles grooves plinth

Illuminazione
 Lighting

Accessori
 Accessories

Componenti e meccanismi
 Components e mechanism

SCHIENALI PER COLONNE RIENTRANTI

Backrests for pocket doors tall units
 Dospour colonnes encastrées
 Traseras para columnas entrantes
 Rückwand für Einschubtüren Element

Schienale fisso con ganci

Fixed backrest with hooks
 Dos fixe avec crochets
 Trasera fija con ganchos
 Feste Rückwand mit Haken



P/D	L/W	L/W	SLOTS	H/H	CODICE	PUNTI
5	60	5	5	52,1	KWW010605250	595
5	90	7	7	52,1	KWW010905250	665
5	120	9	9	52,1	KWW011205250	770

Dotato di asole per l'applicazione di ganci ed accessori, tenere conto dell'ingombro di ogni accessorio per stabilire quanti elementi posizionare

Equipped with slots for attaching hooks and accessories, take into account the footprint of each accessory to determine how many items to place | Équipé de fentes pour la fixation de crochets et d'accessoires, tenez compte de la taille de chaque accessoire pour déterminer le nombre d'éléments à placer | Equipado con ranuras para fijar ganchos y accesorios, tenera en cuenta el tamaño de cada accesorio para determinar cuántos elementos colocar | Ausgestattet mit Schlitzten zum Haken und Zubehör zu hängen, berücksichtigen Sie die Größe jedes Zubehörs, um zu bestimmen, wie viele Elemente zu platzieren

Schienale telescopico con ganci

Telescopic backrest with hooks
 Dos télescopique avec crochets
 Trasera telescópica con ganchos
 Teleskopische Rückwand mit Haken



P/D	L/W	L/W	SLOTS	H/H	CODICE	PUNTI
5	60	5	5	52,1	KWP01060	963
5	90	7	7	52,1	KWP01090	1.026
5	120	9	9	52,1	KWP01120	1.092

Dotato di asole per l'applicazione di ganci ed accessori, tenere conto dell'ingombro di ogni accessorio per stabilire quanti elementi posizionare

Equipped with slots for attaching hooks and accessories, take into account the footprint of each accessory to determine how many items to place | Équipé de fentes pour la fixation de crochets et d'accessoires, tenez compte de la taille de chaque accessoire pour déterminer le nombre d'éléments à placer | Equipado con ranuras para fijar ganchos y accesorios, tenera en cuenta el tamaño de cada accesorio para determinar cuántos elementos colocar | Ausgestattet mit Schlitzten zum Haken und Zubehör zu hängen, berücksichtigen Sie die Größe jedes Zubehörs, um zu bestimmen, wie viele Elemente zu platzieren

Coppia staffe per fissaggio schienali

Pair of brackets for fixing backrests
 Paire de supports pour la fixation des dos
 Pareja de soportes para fijar traseras
 Paar Halterungen zur Rückwand Befestigung

CODICE	PUNTI
KWA000000002	67

ACCESSORI COLONNE RIENTRANTI

Accessories for pocket doors tall units
Accessoires colonnes portes rentrantes
Accesorios columnas retráctiles
Zubehör versenkbare Schränke

Mensola fissa acciaio

Steel fixed shelf
Etagère fixe en acier
Balda fija de acero
Stahlregal



P/D	L/W	H/H	CODICE	PUNTI
36	60	1,8	KWM010603618	917
36	90	1,8	KWM010903618	1.022
36	120	1,8	KWM011203618	1.127
49	60	1,8	KWM010604918	1.040
49	90	1,8	KWM010904918	1.145
49	120	1,8	KWM011204918	1.250

Cassetto interno inox

Stainless steel inner drawer
Tiroir intérieur en acier inoxydable
Cajón interior de acero inoxidable
Innenschublade aus Edelstahl



P/D	L/W	H/H	CODICE	PUNTI
50	60	10,2	KWC010605010	875
50	90	10,2	KWC010905010	980
50	120	10,2	KWC011205010	1.085
50	60	21,4	KWC010605021	1.033
50	90	21,4	KWC010905021	1.138
50	120	21,4	KWC011205021	1.260

Kit prese elettriche

Electric socket kit
Kit de prises électriques
Kit de tomas de corriente
Steckdosen-kit

Ogni schienale dispone di due vani per l'installazione del kit prese elettriche
Each backrest has two compartments for installing the electrical socket kit
Chaque dossier comporte deux compartiments pour l'installation du kit de prises électriques
Cada trasera dispone de dos compartimientos para instalar el kit tomas de corriente
Jede Rückwand hat zwei Fächer für die Installation des Steckdosen-Sets

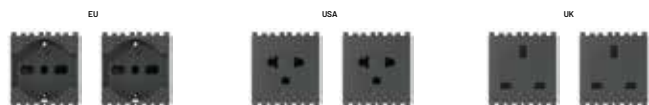

	CODICE	PUNTI
EU	KWPR1EU	228
USA	KWPR1UL	228
UK	KWPR1IN	228

Basi con maniglia
Base units with handle

Basi con gola
Base units with groove

Colonne
Tall units

Pensili
Wall units

Elementi speciali
Special elements

Maniglie gole zoccoli
Handles grooves plinth

Illuminazione
Lighting

Accessori
Accessories

Componenti e meccanismi
Components e mechanism

ACCESSORI COLONNE RIENTRANTI

Accessories for pocket doors tall units
Accessoires colonnes portes rentrantes
Accesorios columnas retráctiles
Zubehör versenkbare Schränke

Mensola fissa porta bottiglie

Fixed bottle holder shelf
Étagère fixe pour porte-bouteilles
Balda fija portabotellas
Flaschenregal



P/D	L/W	H/H	CODICE	PUNTI
25,3	60	18,2	KWM0206027	616
25,3	90	18,2	KWM0209027	690
25,3	120	18,2	KWM0212027	777

Mensola fissa porta calici

Fixed chalice rack shelf
Étagère fixe pour porte-verre
Balda fija porta vasos
Weinregal



P/D	L/W	H/H	CODICE	PUNTI
30	60	3,4	KWM0306030	763
30	90	3,4	KWM0309030	945
30	120	3,4	KWM0312030	1.089

Kit portaspezie con 9 boccette vetro

Spice rack kit with 9 glass flasks
Kit porte-épices avec 9 bouteilles en verre
Kit de especiero con 9 frascos de cristal
Gewürzregal-Set mit 9 Glasflaschen



Ingombro 5 slots
Footprint 5 slots
Encombrement 5 slots
tamaño 5 espacios accesorios
platzbedarf 5 Steckplätze

P/D	L/W	H/H	CODICE	PUNTI
10	21	40,2	KWA000000007	588

ACCESSORI COLONNE RIENTRANTI

Accessories for pocket doors tall units
Accessoires colonnes portes rentrantes
Accesorios columnas retráctiles
Zubehör versenkbare Schränke

Portapellicole doppio in inox

Stainless steel double film holder
Porte-pellicule double en acier inoxydable
Portapelículas doble de acero inoxidable
Doppelter Folienhalter aus Edelstahl

Ingombro 5 slots
Footprint 5 slots
Encombremment 5 slots
tamaño 5 espacios accesorios
platzbedarf 5 Steckplätze

P/D	L/W	H/H	CODICE	PUNTI
6,6	21	40,2	KWA000000006	476



Porta mattarello

Rolling pin holder
Support pour rouleau à pâtisserie
Soporte para rodillo
Mattarellohalter

Ingombro 2 slots
Footprint 2 slots
Encombremment 2 slots
tamaño 2 espacios accesorios
platzbedarf 2 Steckplätze

P/D	L/W	H/H	CODICE	PUNTI
6,3	6	40,2	KWA000000005	228



Porta coltelli universale per 6 coltelli

Universal knife holder for 6 knives
Porte-couteau universel pour 6 couteaux
Portacuchillos universal para 6 cuchillos
6 Stk Messerhalter

Ingombro 5 slots
Footprint 5 slots
Encombremment 5 slots
tamaño 5 espacios accesorios
platzbedarf 5 Steckplätze

P/D	L/W	H/H	CODICE	PUNTI
6,6	21	40,2	KWA000000004	347



Basi con maniglia
Base units with handle

Basi con gola
Base units with groove

Colonne
Tall units

Pensili
Wall units

Elementi speciali
Special elements

Maniglie gole zoccoli
Handles grooves plinth

Illuminazione
Lighting

Accessori
Accessories

Componenti e meccanismi
Components e mechanism

ACCESSORI COLONNE RIENTRANTI

Accessories for pocket doors tall units
Accessoires colonnes portes rentrantes
Accesorios columnas retráctiles
Zubehör versenkbare Schränke

Coppia taglieri in polietilene

Pair of plastic cutting boards
Paire de planches à découper en plastique
Pareja de tablas de cortar de polietileno
Ein Paar Polyethylen-Schneidebretter



Ingombro 4 slots
Footprint 4 slots
Encombrement 4 slots
tamaño 4 espacios accesorios
platzbedarf 4 Steckplätze

P/D	L/W	H/H	CODICE	PUNTI
2	19,1	40,2	KWA000000003	214

Mensola universale

Universal shelf
Étagère universelle
Balda universal
Universal-Regal



Ingombro 5 slots
Footprint 5 slots
Encombrement 5 slots
tamaño 5 espacios accesorios
platzbedarf 5 Steckplätze

P/D	L/W	H/H	CODICE	PUNTI
16,2	21	40,2	KWA000000008	242

Porta tablet

Tablet holder
Porte-tablet
Soporte para tablet
Tablet-Halterung



Ingombro 7 slots
Footprint 7 slots
Encombrement 7 slots
tamaño 7 espacios accesorios
platzbedarf 7 Steckplätze

P/D	L/W	H/H	CODICE	PUNTI
12,6	31	21,6	KWA000000009	200

PATTUMIERE

Dustbins
Poubelles
Papeleras
Abfalleimer

T2

Sistema di raccoglitori pattumiera costituito da basi e coperchi in alluminio verniciato poliestere anti impronta. I secchi sono alti 26 cm e sono compatibili con tutti i sacchetti in commercio. I coperchi dispongono di un filtro antiodore lavabile di serie e sono incernierati sulla cornice premisacchetto.

Waste bin system consisting of bases and lids made of polyester-painted, non-marking aluminium. The bins are 26 cm high and are compatible with all commercially available bags. The lids have a washable odour filter as standard and are hinged to the bag-press frame.

Sistema de cubos de basura compuesto por bases y tapas de aluminio pintado en poliéster antihuellas. Los cubos tienen 26 cm de altura y son compatibles con todas las bolsas disponibles en el mercado. Las tapas llevan estándar un filtro para olores lavable y están enganchadas al bastidor de el marco de las bolsas.

Abfalleimersystem bestehend aus Böden und Deckeln aus polyesterlackiertem, spurlosem Aluminium. Die Eimer haben eine Höhe von 26 cm und sind mit allen handelsüblichen Beuteln kompatibel. Die Deckel sind serienmäßig mit einem auswaschbaren Geruchsfilter ausgestattet und werden mit einem Scharnier am Rahmen der Sackpresse befestigt. Système de poubelles composé de bases et de couvercles en aluminium peint en polyester et non marquant. Les seaux ont une hauteur de 26 cm et sont compatibles avec tous les sacs disponibles dans le commerce. Les couvercles sont équipés de série d'un filtre anti-odeurs lavable et sont fixés par des charnières au cadre de la presse à sacs.



Pattumiera T2 Titanio per cestone L. 60

T2 Titanium dustbin for basket W. 60
Poubelle T2 en titane pour panier L.60
Papelera T2 titanio para cesta A.60
Abfalleimer T2 aus Titan für Schubkast B.60

2 secchi (12 lt + 17 lt)
2 bins (12 l + 17 l)
2 seaux (12 l + 17 l)
2 botes (12 l + 17 l)
2 Eimer (12 l + 17 l)



P/D	L/W	H/H	CODICE	PUNTI
50	60	26	KPT01060TI	155

Pattumiera T2 Titanio per cestone L. 75

T2 Titanium dustbin for basket W. 75
Poubelle T2 en titane pour panier L.75
Papelera T2 titanio para cesta A.75
Abfalleimer T2 aus Titan für Schubkast B.75

2 secchi (12 lt + 17 lt)
2 bins (12 l + 17 l)
2 seaux (12 l + 17 l)
2 botes (12 l + 17 l)
2 Eimer (12 l + 17 l)



P/D	L/W	H/H	CODICE	PUNTI
50	75	26	KPT01075TI	214

Basi con maniglia
Base units with handle

Basi con gola
Base units with groove

Colonne
Tall units

Pensili
Wall units

Elementi speciali
Special elements

Maniglie gole zoccoli
Handles grooves plinth

Illuminazione
Lighting

Accessori
Accessories

Componenti e meccanismi
Components e mechanism

PATTUMIERE

Dustbins
Poubelles
Papeleras
Abfalleimer

T2

Pattumiera T2 Titanio per cestone L. 90

T2 Titanium dustbin for basket W. 90
Poubelle T2 Titane pour panier L.90
Papelera T2 titanio para cesta A.90
Abfalleimer T2 aus Titan für Schubkast B.90

3 secchi (12 lt + 17 lt + 17 lt)
3 bins (12 lt + 17 lt)
3 seaux (12 lt + 17 lt)
3 botes (12 lt + 17 lt)
3 Eimer (12 l + 17 l)

P/D	L/W	H/H	CODICE	PUNTI
50	90	26	KPT01090TI	214



Pattumiera T2 Titanio per cestone L. 105

T2 Titanium dustbin for basket W. 105
Poubelle T2 en titane pour panier L.105
Papelera T2 titanio para cesta A.105
Abfalleimer T2 aus Titan für Schubkast B.105

3 secchi (12 lt + 17 lt + 17 lt)
3 bins (12 lt + 17 lt)
3 seaux (12 lt + 17 lt)
3 botes (12 lt + 17 lt)
3 Eimer (12 l + 17 l)

P/D	L/W	H/H	CODICE	PUNTI
50	105	26	KPT01105TI	294



Pattumiera T2 Titanio per cestone L. 120

T2 Titanium dustbin for basket W. 120
Poubelle T2 en titane pour panier L.120
Papelera T2 titanio para cesta A.120
Abfalleimer T2 aus Titan für Schubkast B.120

4 secchi (12 lt + 17 lt + 17 lt + 17 lt)
4 bins (12 l + 17 l + 17 l + 17 l)
4 seaux (12 l + 17 l + 17 l + 17 l)
4 botes (12 l + 17 l + 17 l + 17 l)
4 Eimer (12 l + 17 l + 17 l + 17 l)

P/D	L/W	H/H	CODICE	PUNTI
50	120	26	KPT01120TI	294



PATTUMIERE

Dustbins
Poubelles
Papeleras
Abfalleimer

BASE SYSTEM

Base System è un sistema di pattumiere per moduli con anta battente ed è costituito da elementi scorrevoli in grado di essere agganciati/sganciati rapidamente per un eventuale accesso agli impianti sottolavello. Il sistema è realizzato in alluminio verniciato titanio.

Base System is a system of bins for modules with hinged doors and consists of sliding elements that can be quickly hooked/unhooked for possible access to under-sink installations. The system is made of titanium-coated aluminium.

Base System es un sistema de botes para módulos con puertas batientes y consta de elementos deslizantes que pueden engancharse/desengancharse rápidamente para facilitar el acceso a las instalaciones bajo fregadero. El sistema está en aluminio con revestimiento de titanio. Base System ist ein von Behältern-System für Module mit Flügeltüren und besteht aus Schiebeelementen, die schnell ein- und ausgehängt werden können, um den Zugang zu Untertischinstallationen zu ermöglichen. Das System ist aus titanbeschichtetem Aluminium gefertigt. Base System est un système depoubelles pour modules avec portes battantes, composé d'éléments coulissants qui peuvent être rapidement accrochés/décrochés pour permettre l'accès aux installations sous l'évier. Le système est fabriqué en aluminium verni titane.



Pattumiera Base System per base anta L. 60

Base System dustbin for door base W. 60
Poubelle Base Système pour base porte L.60
Papelera Base System para base puerta A.60
Abfalleimer Base System für Unterschrank B.60



2 secchi (12 lt + 12 lt), 1 contenitore a vaschetta
2 bins (12 l + 12 l), 1 tray container
2 seaux (12 l + 12 l), 1 conteneur à plateau
2 botes (12 l + 12 l), 1 contenedor bandeja
2 Eimer (12 l + 12 l), 1 Schalenbehälter

P/D	L/W	H/H	CODICE	PUNTI
50	60	26	KPT02060TI	391

Pattumiera Base System per base anta L. 75

Base System dustbin for door base W. 75
Poubelle Base Système pour base porte L.75
Papelera Base System para base puerta A.75
Abfalleimer Base System für Unterschrank B.75



2 secchi, 1 contenitore a vaschetta
2 bins, 1 tray container
2 seaux, 1 bac
2 botes, 1 bandeja contenedor
2 Eimer, 1 Schalenbehälter

P/D	L/W	H/H	CODICE	PUNTI
50	75	26	KPT02075TI	586

Basi con maniglia
Base units with handle

Basi con gola
Base units with groove

Colonne
Tall units

Pensili
Wall units

Elementi speciali
Special elements

Maniglie gole zoccoli
Handles grooves plinth

Illuminazione
Lighting

Accessori
Accessories

Componenti e meccanismi
Components e mechanism

PATTUMIERE

Dustbins
Poubelles
Papeleras
Abfalleimer

BASE SYSTEM

Pattumiera Base System per base anta L. 90

Base System dustbin for door base W. 90
Poubelle Base Système pour base porte L.90
Papelera Base System para base puerta A.90
Abfalleimer Base System für Unterschrank B.90

3 secchi, 2 contenitori a vaschetta
3 bins, 2 tubs
3 seaux, 2 bacs
3 botes, 2 bañeras
3 Eimer, 2 Wannen

P/D	L/W	H/H	CODICE	PUNTI
50	90	26	KPT02090TI	586



Pattumiera Base System per base anta L. 105

Base System dustbin for door base W. 105
Poubelle Base Système pour base porte L.105
Papelera Base System para base puerta A.105
Abfalleimer Base System für Unterschrank B.105

3 secchi, 2 contenitori a vaschetta
3 bins, 2 tubs
3 seaux, 2 bacs
3 botes, 2 bañeras
3 Eimer, 2 Wannen

P/D	L/W	H/H	CODICE	PUNTI
50	105	26	KPT02105TI	648



Pattumiera Base System per base anta L. 120

Base System dustbin for door base W. 120
Poubelle Base Système pour base porte e L.120
Papelera Base System para base puerta A.120
Abfalleimer Base System für Unterschrank B.120

4 secchi, 3 contenitori a vaschetta
4 bins, 3 tubs
4 seaux, 3 bacs
4 botes, 3 bañeras
4 Eimer, 3 Wannen

P/D	L/W	H/H	CODICE	PUNTI
50	120	26	KPT02120TI	648



PATTUMIERE

Dustbins
Poubelles
Papeleiras
Abfalleimer

Pattumiere a libera installazione per basi lavello con ante. Pattumiere in acciaio inox caratterizzate dal design compatto e dalla semplicità di montaggio. L'estrazione totale delle guide agevola l'accessibilità ai contenitori e rende facili eventuali interventi nella zona sotto il lavello.

Free-standing garbage cans for sink base units with doors. Stainless steel garbage cans characterized by compact design and easy assembly. The full extraction of the guides facilitates accessibility to the bins and makes any work in the area under the sink easy.

Cubos de basura autoportantes para bases de fregadero con puertas. Cubos de acero inoxidable caracterizados por su diseño compacto y fácil montaje. La extensión total de las guías facilita la accesibilidad a los contenedores y facilita cualquier trabajo en la zona bajo el fregadero.

Freistehende Mülleimer für Spülbecken mit Türen. Behälter aus rostfreiem Stahl, die sich durch ihre kompakte Bauweise und einfache Montage auszeichnen. Der Vollauszug der Führungen erleichtert die Zugänglichkeit zu den Behältern und erleichtert alle Arbeiten im Bereich unter der Spüle. Poubelles autoportantes pour éviers avec portes. Poubelles en acier inoxydable caractérisées par leur conception compacte et leur facilité de montage. L'extension complète des glissières facilite l'accès aux contenants et facilite tout travail dans la zone sous l'évier.

ESTRAIBILE PER ANTA



Pattumiera a carrello

Trolley dustbin
Poubelle sur chariot
Papelera con ruedas
Ausziehbarer Abfalleimer



2 contenitori in plastica
2 plastic containers
2 récipients en plastique
2 recipientes de plástico
2 Kunststoffbehälter

P/D	L/W	H/H	CODICE	PUNTI
41,5	31	33,5	KPT03PL	112

Pattumiera a carrello

Trolley dustbin
Poubelle sur chariot
Papelera con ruedas
Ausziehbarer Abfalleimer



2 contenitori riavvolti in acciaio inox
2 stainless steel rewound containers
2 conteneurs en acier inoxydable rembobinés
2 recipientes de acero inoxidable rebobinados
2 aufgewickelte Behälter aus rostfreiem Stahl

P/D	L/W	H/H	CODICE	PUNTI
41,5	31	33,5	KPT03IX	284

Basi con maniglia
Base units with handle

Basi con gola
Base units with groove

Colonne
Tall units

Pensili
Wall units

Elementi speciali
Special elements

Maniglie gole zoccoli
Handles grooves plinth

Illuminazione
Lighting

Accessori
Accessories

Componenti e meccanismi
Components e mechanism

SISTEMA HANG SOTTOPENSILE

Under-cabinet Hang System
 Système de suspension sous l'armoire
 Sistema Hang bajo colgante
 Unterschrank-Hängesystem

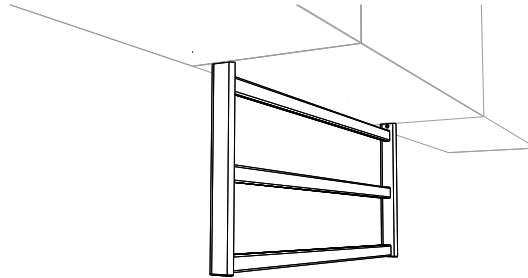

Hang sottopensile nero

Black under-cabinet hangers
 Cintres noirs sous l'armoire
 Perchas negras bajo colgante
 Schwarze Kleiderbügel für Unterschränke

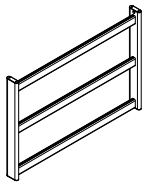

P/D	L/W	H/H	CODICE	PUNTI
5	60	40,4	KHAPN0600	221
5	90	40,4	KHAPN0900	259
5	120	40,4	KHAPN1200	336

Hang sottopensile nero doppio

Double black under-cabinet hangers
 Double suspension noire sous l'armoire
 Perchas dobles negras bajo colgante
 Doppelte schwarze Unterschrankbügel

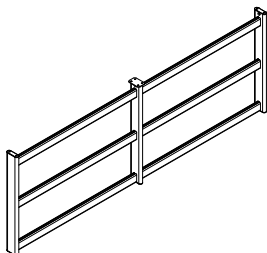

P/D	L/W	H/H	CODICE	PUNTI
5	60+60	40,4	KHAPN6060	420
5	90+90	40,4	KHAPN9090	499

SISTEMA HANG SOPRAPIANO

Hang overhead system
Système de suspension
Sistema Hang sobre encimera
Hang system ueber top

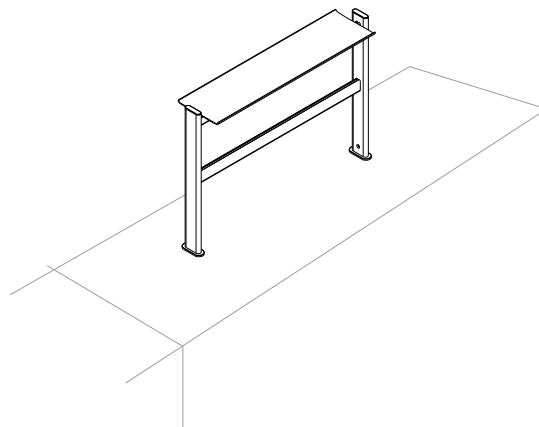

Hang top 2 nero

Hang top 2 black
Accrocher le haut 2 noir
Percha top 2 negro
Top 2 schwarz aufhängen

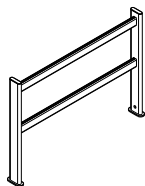

P/D	L/W	H/H	CODICE	PUNTI
5	60	40,4	KHATN0600	182
5	90	40,4	KHATN0900	223
5	120	40,4	KHATN1200	234

Hang top 2 nero doppio

Hang top 2 black double
Accrocher 2 doubles noirs
Percha top 2 negro doble
Hängen Sie oben 2 schwarze Doppel

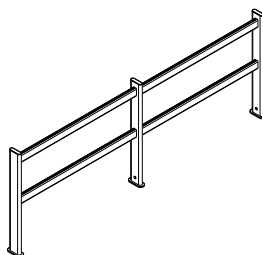

P/D	L/W	H/H	CODICE	PUNTI
5	60	40,4	KHATN6060	324
5	90	40,4	KHATN9090	385

Basi con maniglia
Base units with handle

Basi con gola
Base units with groove

Colonne
Tall units

Pensili
Wall units

Elementi speciali
Special elements

Maniglie gole zoccoli
Handles grooves plinth

Illuminazione
Lighting

Accessori
Accessories

Componenti e meccanismi
Components e mechanism

ACCESSORI HANG

Hang Accessories
Accessoires Hang
Accesorios Hang
Zubehör aufhängen

Mensola nera Hang

Black Hang shelf
Étagère noire Hang
Balda negra Hang
Schwarzes Regal Hang



L/W	CODICE	PUNTI
60	KHAMN0600	30
90	KHAMN0900	45
120	KHAMN1200	62

Portarotolo nero per Hang

Black roll holder for Hang
Porte-rouleau noir pour Hang
Portarrollos negro para Hang
Schwarzer Rollenhalter für Hang

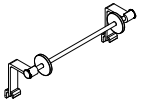

CODICE	PUNTI
KHANACC01	50

Set 3 ganci neri parte superiore

Set 3 black hooks upper part
Jeu de 3 crochets noirs partie supérieure
Juego de 3 ganchos negros parte superior
Satz mit 3 schwarzen Haken Oberteil

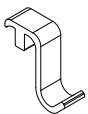

Solo per Hang sotto pensile
Only for Hang under wall unit
Uniquement pour l'accrochage sous l'unité murale
Solo para Hang bajo colganteo
Nur für die Aufhängung unter dem Hängeschrank

CODICE	PUNTI
KHANACC02	8

ACCESSORI HANG

Hang Accessories
Accessoires Hang
Accesorios Hang
Zubehör aufhängen

Set 3 ganci neri parte inferiore

Set of 3 black hooks lower part
Jeu de 3 crochets noirs partie inférieure
Juego de 3 ganchos negros parte inferior
Satz mit 3 schwarzen Haken Unterteil



Solo per Hang sopra piano

Only for Hang over floor
Uniquement pour l'accrochage au sol
Solo para Hang sobre encimera
Nur für Hang over floor

CODICE	PUNTI
KHANACC03	8

Basi con maniglia
Base units with handle

Basi con gola
Base units with groove

Colonne
Tall units

Pensili
Wall units

Elementi speciali
Special elements

Maniglie gole zoccoli
Handles grooves plinth

Illuminazione
Lighting

Accessori
Accessories

Componenti e meccanismi
Components e mechanism

Tagliere nero e faggio

Black and beech chopping board
Planche à découper en hêtre et noir
Tabla de cortar de haya color negra
Schneidebrett in Schwarz und Buche

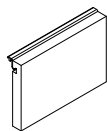

CODICE	PUNTI
KHANACC04	107

Portacoltelli nero e faggio

Black and beech knife holder
Porte-couteau en hêtre et noir
Portacuchillos negro en haya
Messerhalter in Schwarz und Buche

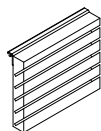

CODICE	PUNTI
KHANACC05	116

ACCESSORI LINERO MOSAIQ

Linero MosaiQ accessories
 Accessoires Linero MosaiQ
 Accesorios Linero MosaiQ
 Zubehör Linero MosaiQ



Set profilo di alluminio

Aluminum profile set
 Kit profil en aluminium
 Juego de perfiles de aluminio
 Aluminium-Profilersatz



P/D	L/W	H/H	CODICE	PUNTI
3,3	90	4,2	KPRK10904033	111
3,3	120	4,2	KPRK11204033	142
3,3	150	4,2	KPRK11504033	173

Portacoltelli magnetico

Magnetic knife holder
 Porte-couteau magnétique
 Portacuchillos magnético
 Magnetischer Messerhalter



Finitura titanium grey con inserto rovere

Titanium grey finish with oak insert
 Finition gris titane avec insert en chêne
 Acabado gris titanio con inserción de roble
 Ausführung Titangrau lackiert mit Eichenholzeinsatz

P/D	L/W	H/H	CODICE	PUNTI
4,5	35	20	KALMK0000001	274

ACCESSORI LINERO MOSAIQ

Linero MosaiQ accessories
Accessoires Linero MosaiQ
Accesorios Linero MosaiQ
Zubehör Linero MosaiQ

Porta rotolo

Roll holder
Porte-rouleau
Portarrollos
Papierrollenhalter



Finitura titanium grey, vano per rotoli di carta da cucina fino a 29,5 cm di lunghezza

Titanium grey finish, compartment for paper towel rolls up to 29.5 cm long
Finition gris titane, compartiment pour rouleaux de papier d'une longueur maximale de 29,5 cm
Acabado gris titanio, compartimento para rollos de papel de hasta 29,5 cm de longitud
Titangraue Ausführung, Fach für Papierrollen bis 29,5 cm Länge

P/D	L/W	H/H	CODICE	PUNTI
15,5	35	12	KALMK0000002	56

Porta pellicole

Film holder
Porte-pellicule
Soporte para película
Filmhalter



Finitura titanium grey, adatto a rotoli fino a 330 mm di lunghezza

Titanium grey finish, suitable for rolls up to 330 mm long
Finition gris titane, convient pour des rouleaux d'une longueur maximale de 330 mm
Acabado gris titanio, adecuado para rollos de hasta 330 mm de longitud
Titangrau lackiert, geeignet für Rollenlängen bis 330 mm

P/D	L/W	H/H	CODICE	PUNTI
11	35	30	KALMK0000003	182

Contenitore magnetico in plastica

Plastic magnetic container
Récipient en plastique magnétique
Recipiente magnético de plástico
Magnetischer Kunststoffbehälter



Comprensivo di divisorio estraibile

Including removable divider
Y compris une cloison amovible
Incluye divisorio extraíble
Einschließlich herausnehmbarer Trennwand

P/D	L/W	H/H	CODICE	PUNTI
13,5	13,5	15,6	KALMK0000004	28

Basi con maniglia
Base units with handle

Basi con gola
Base units with groove

Colonne
Tall units

Pensili
Wall units

Elementi speciali
Special elements

Maniglie gole zoccoli
Handles grooves plinth

Illuminazione
Lighting

Accessori
Accessories

Componenti e meccanismi
Components e mechanism

ACCESSORI LINERO MOSAIQ

Linero MosaiQ accessories
Accessoires Linero MosaiQ
Accesorios Linero MosaiQ
Zubehör Linero MosaiQ

Mensola porta oggetti

Object shelf
Étagère porte-objets
Balda para objetos
Regal



Finitura titanium grey, superficie di appoggio: 35 x 10,7 cm

Titanium grey finish, supporting surface: 35 x 10,7 cm
Finition gris titane, surface d'appui : 35 x 10,7 cm
Acabado gris titanio, superficie de apoyo: 35 x 10,7 cm
Titangrau lackiert, Auflagefläche: 35 x 10,7 cm

P/D	L/W	H/H	CODICE	PUNTI
11	35	20	KALMK0000005	67

Mensola a due ganci con aggancio profilo inferiore

Two-hook shelf with lower profile attachment
Étagère à deux crochets avec fixation profil inférieur
Balda de dos ganchos con fijación perfil inferior
Ablage mit zwei Halterungen und unterer Profilbefestigung



Finitura titanium grey

Titanium grey finish
Finition gris titane
Acabado gris titanio
Titangrau lackiert

P/D	L/W	H/H	CODICE	PUNTI
4,4	85	3,8	KALMK0000006	19

Mensola con lavagnetta magnetica

Shelf with magnetic board
Étagère avec tableau magnétique
Balda con pizarra magnética
Regal mit Magnettafel



Finitura titanium grey, lato posteriore in vetro scrivibile-lavabile e a cui si possono attaccare le calamite

Titanium grey finish, writable-washable glass back side to which magnets can be attached
Finition gris titane, face arrière en verre inscriptible et lavable sur laquelle des aimants peuvent être fixés
Acabado gris titanio, reverso de cristal lavable en el que se pueden fijar imanes
Titangraue Ausführung, Rückseite aus beschreibbarem, abwaschbarem Glas, an dem Magnete befestigt werden können

P/D	L/W	H/H	CODICE	PUNTI
11	35	30	KALMK0000008	137

ACCESSORI LINERO MOSAIQ

Linero MosaiQ accessories
Accessoires Linero MosaiQ
Accesorios Linero MosaiQ
Zubehör Linero MosaiQ

Mensola superiore

Top shelf
Étagère supérieure
Balda superior
Oberes Regal

Finitura titanium grey
Titanium grey finish
Finition gris titane
Acabado gris titanio
Titangrau lackiert



P/D	L/W	H/H	CODICE	PUNTI
10,7	35	0,8	KALMK0000007	35

Listello decorativo in legno per mensola superiore

Decorative wooden lath for top shelf
Latte décorative en bois pour l'étagère supérieure
Listón decorativo de madera para el estante superior
Dekorative Holzleiste für die obere Ablage



P/D	L/W	H/H	CODICE	PUNTI
10,6	32	0,4	KALMK0000009	34

Listello decorativo in vetro fumè per mensola superiore

Decorative smoked glass strip for top shelf
Bande décorative en verre fumé pour le plateau supérieur
Listón decorativo de cristal ahumado para el estante superior
Dekorative Rauchglasleiste für die obere Ablage



P/D	L/W	H/H	CODICE	PUNTI
10,6	35	0,4	KALMK0000010	29

Basi con maniglia
Base units with handle

Basi con gola
Base units with groove

Colonne
Tall units

Pensili
Wall units

Elementi speciali
Special elements

Maniglie gole zoccoli
Handles grooves plinth

Illuminazione
Lighting

Accessori
Accessories

Componenti e meccanismi
Components e mechanism

BARRA ELETTRIFICATA

Electrified bar
Barre électrifiée
Barra electrificada
Elektrifizierter Stab



Profilo elettrificato L. 50 cm
Electrified profile L. 50 cm
Profilé électrifié L. 50 cm
Perfil electrificado L. 50 cm
Elektrifiziertes Profil L. 50 cm



L/W	CODICE	PUNTI
50	KIBE305006	243

BARRA ELETTRIFICATA

Electrified bar
Barre électrifiée
Barra electrificada
Elektrifizierter Stab

Profilo

Profile
Profil
Perfil
Profil

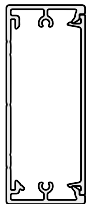

P/D	L/W	H/H	CODICE	PUNTI
2,8	ml	7	KIBE1000	29

Profilo di chiusura

Closure profile
Profil de clôtüre
Perfil de cierre
Abschlussprofil

L/W	CODICE	PUNTI
ml	KIBE2000	25

Coppia tappi di chiusura

Pair of end caps
Paire d'embouts
Pareja de tapas para cerrar
Paar Endkappen

CODICE	PUNTI
KIBE0000001	26

Basi con maniglia
Base units with handle

Basi con gola
Base units with groove

Colonne
Tall units

Pensili
Wall units

Elementi speciali
Special elements

Maniglie gole zoccoli
Handles grooves plinth

Illuminazione
Lighting

Accessori
Accessories

Componenti e meccanismi
Components e mechanism

BARRA ELETTRIFICATA

Electrified bar
Barre électrifiée
Barra electrificada
Elektrifizierter Stab

Kit prese

Socket kits
Kits de prises
Kits de enchufes
Steckdosen-kit



	CODICE	PUNTI
Schuko	KIBE00000002	105
International	KIBE00000003	105
France	KIBE00000004	105

Cassa audio bluetooth

Bluetooth audio speaker
Haut-parleur audio Bluetooth
Altavoz de audio Bluetooth
Bluetooth-Audio-Lautsprecher



L/W	CODICE	PUNTI
cad.	KIBE00000005	127

COMPONENTI E MECCANISMI

Components and mechanisms
Composants et mécanismes
Componentes y mecanismos
Komponenten und Mechanismen

FIANCHI DI FINITURA Finishing sides Côtés de finition Laterales acabados Côtés de finition	P. 354
SPALLE Side panels Côtés Laterales Aussenseiten	P. 358
PANNELLI Panels Panneaux Paneles Paneele	P. 373
MENSOLE Shelves Étagères Estanterías Regale	P. 382
FRONTALI Fronts Façades Frentes Fronten	P. 387
CERNIERE Hinges Charnières Bisagras Scharniere	P. 393
STRUTTURE CASSETTI E CESTONI Drawer and basket structures Structures de tiroirs et de paniers Estructuras de cajones y cestas Schubladen- und Schubkaststrukturen	P. 394
SISTEMI DI APERTURA PER ANTE Door opening systems Systèmes d'ouverture des portes Sistemas de apertura para puertas Türöffnungssysteme	P. 397
RIPIANI E DIVISIONI Shelves and divisions Étagères et cloisons Estantes y divisorios Fachböden und Trennwände	P. 399
ATTREZZATURE PER MOBILI Furniture equipment Équipement des meubles Equipamiento para mobiliario Möbelausstattung	P. 403
MECCANISMI Mechanisms Mécanismes Mecanismos Mechanismen	P. 404
<ul style="list-style-type: none">MECCANISMI SIGE Sige Mechanisms Mécanismes Sige Mecanismos Sige Sige MechanismenMECCANISMI KESSEMBHOMER Kessembhomer mechanisms Mécanismes de Kessembhomer Mecanismos Kessembhomer Kessembhomer-Mechanismen	<p>P. 404</p> <p>P. 407</p>
PIEDINI Feet Pieds Patas Füße	P. 410

Basi con maniglia
Base units with handle

Basi con gola
Base units with groove

Colonne
Tall units

Pensili
Wall units

Elementi speciali
Special elements

Maniglie gole zoccoli
Handles grooves plinth

Illuminazione
Lighting

Accessori
Accessories

Componenti e meccanismi
Components e mechanism

FIANCHI DI FINITURA

Finishing sides
Côtés de finition
Laterales acabados
Aussenseiten

Fianchi di finitura sp.1,8 in sostituzione del fianco di serie. Individuare nella tabella la finitura desiderata per trovare tempi di consegna e fascia di prezzo della maggiorazione.

1.8-thick finish sides as a replacement for the standard side panel. Locate the desired finish in the table to find delivery time and price range of the surcharge.

Côtés de finition ép. 1,8 pour remplacer le panneau latéral standard. Repérez la finition souhaitée dans le tableau pour connaître le délai de livraison et la catégorie de prix du supplément.

Laterales acabados esp. 1,8 mm como alternativa al lateral estándar. Localizar el acabado deseado en el muestrario y tomar nota del plazo de entrega y de la categoría de precio del recargo.

1,8 mm dicke Aussenseiten als Ersatz für die Standard-Seitenwand. Suchen Sie die gewünschte Ausführung in der Tabelle, um die Lieferzeit und die Preisklasse des Aufpreises zu finden.

FINITURE FINISHES FINITIONS ACABADOS AUSFÜHRUNG	SETTIMANE WEEKS SEMAINES SEMANAS WOCHEN	FASCIA DI PREZZO PRICE RANGE CATÉGORIE DE PRIX CATAGORÍA DE PRECIO PREISKLASSE
<ul style="list-style-type: none"> MATERICO TEXTURED FINISH MU0 Bianco, MU1 Sabbia, MU2 Alpaca, MU3 Quarzo MS0 Centauri, MS1 Eris, MS2 Bronzo, MS3 Metallo MR0 Perla, MR1 Argilla, MR2 Lava ML0 Noce California, ML1 Noce Alabama, ML2 Rovere Virginia, ML3 Rovere Termotrattato 	4	0
<ul style="list-style-type: none"> ULTRAMAT ULTRAMAT EM0 Bianco, EM1 Talpa, EM2 Lino, EM3 Mineral grey, EM4 Wine, EM5 Nero 	4	2
<ul style="list-style-type: none"> ULTRAGLOSS ULTRAGLOSS EL0 Bianco, EL1 Talpa, EL2 Lino 	4	2
<ul style="list-style-type: none"> LACCATO OPACO MATT LACQUER O10 Bianco, O00 Panna, O01 Crema, O02 Grigio Perla, O03 Grigio Seta, O04 Corda, O05 Moka, O06 Blu Cobalto, O07 Grigio Aston, O08 Grigio Antracite, O09 Nero 	5	3
<ul style="list-style-type: none"> FENIX NTM® FENIX NTM® FM0 Bianco Kos, FM1 Beige Arizona, FM2 Castoro Ottawa, FM3 Grigio Londra, FM4 Rosso Jaipur, FM5 Verde Comodoro, FM6 Nero Ingo 	5	4
<ul style="list-style-type: none"> LACCATO LUCIDO GLOSSY LACQUERED L10Bianco, L00 Panna, L01 Crema, L02 Grigio Perla, L03 Grigio Seta, L04 Corda, L05 Moka, L06 Blu Cobalto, L07 Grigio Aston, L08 Grigio Antracite, L09 Nero 	6	5
<ul style="list-style-type: none"> ESSENZA 1 WOOD 1 ER0 Rovere Visone, ER1 Rovere Castoro, ER2 Rovere Carbone, ER3 Rovere Cenere 	8	7
<ul style="list-style-type: none"> FENIX NTA® FENIX NTA® FA0 Hamilton, FA1 Dukat, FA2 Cortez 	5	8
<ul style="list-style-type: none"> LACCATO METALLO LACQUERED METAL L00 Ottone, L01 Acciaio, L02 Bronzo LS0 Oro, LS1 Ottone, LS2 Bronzo scuro, LS3 Titanio LA0 Ottone, LA1 Bronzo scuro, LA2 Silicio 	8	9
<ul style="list-style-type: none"> ESSENZA 2 WOOD 2 EE0 Noce Canaletto, EE1 Rovere Termotrattato 	8	9

FIANCHI DI FINITURA

Finishing sides
Côtés de finition
Laterales acabados
Aussenseiten

Profondità 34

Depth 34
Profondeur 34
Profundidad 34
Tiefe 34

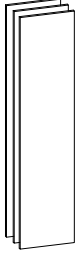

P/D	H/H	0	1	2	3	4	5	6	7	8	9	10
34	39	24	-	31	36	45	48	-	63	73	77	-
34	40,5	24	-	32	37	47	50	-	65	76	80	-
34	45,5	25	-	35	39	52	56	-	73	86	90	-
34	48,5	25	-	37	41	49	59	-	78	86	96	-
34	57	30	-	41	46	57	63	-	92	98	112	-
34	58,5	30	-	42	48	59	65	-	94	100	116	-
34	61,5	30	-	44	50	62	68	-	99	105	122	-
34	72	37	-	50	56	72	80	-	116	124	142	-
34	78	37	-	53	61	78	87	-	125	134	154	-
34	81	39	-	55	63	81	90	-	130	139	160	-
34	87	39	-	58	67	88	97	-	140	149	172	-
34	102	46	-	66	77	100	113	-	164	171	202	-
34	132	56	-	83	97	130	146	-	212	221	261	-
34	195	72	-	117	139	183	216	-	313	322	385	-
34	210	75	-	126	150	192	233	-	337	340	415	-
34	225	79	-	134	160	206	249	-	361	365	444	-
34	240	91	-	142	170	220	266	-	385	392	474	-

Profondità 57

Depth 57
Profondeur 57
Profundidad 57
Tiefe 57

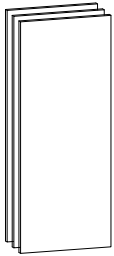

P/D	H/H	0	1	2	3	4	5	6	7	8	9	10
57	39	41	-	45	52	66	73	-	105	112	129	-
57	40,5	41	-	47	54	68	75	-	109	116	134	-
57	45,5	42	-	51	59	77	85	-	122	131	151	-
57	48,5	42	-	53	63	82	90	-	130	139	161	-
57	58,5	43	-	61	74	97	109	-	157	164	194	-
57	61,5	43	-	64	77	101	114	-	165	173	204	-
57	78	46	-	77	96	129	145	-	209	220	258	-
57	81	48	-	80	99	134	150	-	217	228	270	-
57	99	54	-	94	119	156	183	-	266	282	327	-
57	132	98	-	121	156	203	244	-	354	365	436	-
57	195	99	-	172	227	299	360	-	523	532	644	-
57	210	105	-	184	244	322	388	-	563	575	694	-
57	225	111	-	196	260	345	416	-	603	612	743	-
57	240	129	-	209	277	368	443	-	643	649	793	-

Basi con maniglia
Base units with handle

Basi con gola
Base units with groove

Colonne
Tall units

Pensili
Wall units

Elementi speciali
Special elements

Maniglie gole zoccoli
Handles grooves plinth

Illuminazione
Lighting

Accessori
Accessories

Componenti e meccanismi
Components e mechanism

FIANCHI DI FINITURA

Finishing sides
Côtés de finition
Laterales acabados
Aussenseiten

Profondità 62

Depth 62
Profondeur 62
Profundidad 62
Tiefe 62

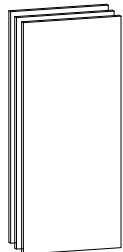

P/D	H/H	0	1	2	3	4	5	6	7	8	9	10
62	39	43	-	47	56	71	79	-	114	122	141	-
62	40,5	43	-	48	58	74	82	-	119	126	146	-
62	45,5	44	-	53	64	83	92	-	133	142	164	-
62	48,5	44	-	55	68	87	98	-	142	148	175	-
62	58,5	46	-	65	80	105	118	-	171	179	211	-
62	61,5	46	-	68	83	110	124	-	180	188	221	-
62	78	50	-	82	103	140	157	-	228	239	281	-
62	81	52	-	85	107	139	163	-	236	246	293	-
62	99	57	-	102	129	170	199	-	289	302	356	-
62	132	103	-	133	169	221	265	-	385	394	474	-
62	195	104	-	191	246	326	392	-	568	573	700	-
62	210	110	-	205	264	350	422	-	612	618	754	-
62	225	116	-	219	282	376	452	-	656	663	808	-
62	240	134	-	232	300	400	482	-	699	708	862	-

Profondità 67

Depth 67
Profondeur 67
Profundidad 67
Tiefe 67

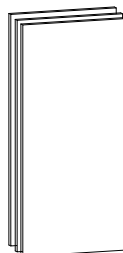

P/D	H/H	0	1	2	3	4	5	6	7	8	9	10
67	39	46	-	52	60	77	85	-	115	132	152	-
67	40,5	46	-	53	62	80	89	-	128	137	158	-
67	45,5	47	-	58	68	88	99	-	144	150	177	-
67	48,5	47	-	60	72	94	106	-	153	160	189	-
67	58,5	48	-	70	85	113	128	-	185	193	228	-
67	61,5	48	-	72	89	119	134	-	194	203	239	-
67	78	51	-	88	111	144	170	-	246	256	303	-
67	81	53	-	90	115	150	176	-	255	266	315	-
67	99	59	-	107	132	183	215	-	312	323	385	-
67	132	109	-	138	182	238	287	-	416	425	513	-
67	195	112	-	196	265	352	423	-	614	625	756	-
67	210	113	-	210	284	379	456	-	661	672	815	-
67	225	118	-	224	304	406	488	-	708	719	873	-
67	240	141	-	237	324	433	521	-	756	762	931	-

FIANCHI DI FINITURA

Finishing sides
Côtés de finition
Laterales acabados
Aussenseiten

Profondità 72

Depth 72
Profondeur 72
Profundidad 72
Tiefe 72

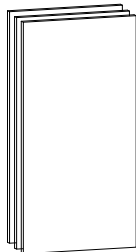

P/D	H/H	0	1	2	3	4	5	6	7	8	9	10
67	39	48	-	57	64	83	92	-	132	141	163	-
67	40,5	48	-	58	66	86	95	-	138	147	170	-
67	45,5	49	-	63	73	95	107	-	154	162	190	-
67	48,5	49	-	65	77	101	114	-	165	172	203	-
67	58,5	51	-	75	91	122	137	-	198	208	245	-
67	61,5	51	-	77	95	128	144	-	209	219	257	-
67	78	55	-	93	119	155	182	-	264	272	326	-
67	81	57	-	95	123	161	189	-	274	279	338	-
67	99	62	-	112	148	192	231	-	335	344	413	-
67	132	114	-	143	195	256	308	-	447	455	551	-
67	195	117	-	201	284	378	454	-	660	672	813	-
67	210	118	-	215	305	407	489	-	710	721	876	-
67	225	123	-	229	326	436	524	-	761	770	938	-
67	240	146	-	242	347	465	559	-	812	823	1000	-

Basi con maniglia
Base units with handle

Basi con gola
Base units with groove

Colonne
Tall units

Pensili
Wall units

Elementi speciali
Special elements

Maniglie gole zoccoli
Handles grooves plinth

Illuminazione
Lighting

Accessori
Accessories

Componenti e meccanismi
Components e mechanism

FINITURE SPALLE

side panels finishes
 finitions des épaules
 acabados de laterales
 ausführungen der Seitenwände

Spalle terminali disponibili con o senza staffe di fissaggio. Individuare nella tabella la finitura desiderata per trovare tempi di consegna e fascia di prezzo.

End side panels available with or without mounting brackets. Locate the desired finish in the table to find delivery time and price range.

Les côtés d'extrémité sont disponibles avec ou sans supports de fixation. Localisez la finition souhaitée dans le tableau pour connaître le délai de livraison et la fourchette de prix.

Laterales disponibles con o sin soportes de fijación. Localice el acabado deseado en la tabla para conocer el plazo de entrega y el rango de precios.

Die Endaussenseiten sind mit oder ohne Befestigungsklammern erhältlich. Suchen Sie in der Tabelle nach der gewünschten Ausführung, um Lieferzeit und Preisspanne zu erfahren.

FINITURE FINISHES FINITIONS ACABADOS AUSFÜHRUNG	SETTIMANE WEEKS SEMAINES SEMANAS WOCHEN	FASCIA DI PREZZO PRICE RANGE CATÉGORIE DE PRIX CATEGORÍA DE PRECIO PREISKLASSE
<ul style="list-style-type: none"> MATERICO TEXTURED FINISH MU0 Bianco, MU1 Sabbia, MU2 Alpaca, MU3 Quarzo MR0 Perla, MR1 Argilla, MR2 Lava ML0 Noce California, ML1 Noce Alabama, ML2 Rovere Virginia, ML3 Rovere Termotrattato 	4	A
<ul style="list-style-type: none"> MATERICO TEXTURED FINISH MS0 Centauri, MS1 Eris, MS2 Bronzo, MS3 Metallo 	4	B
<ul style="list-style-type: none"> ULTRAMAT ULTRAMAT EM0 Bianco, EM1 Talpa, EM2 Lino, EM3 Mineral grey, EM4 Wine, EM5 Nero 	4	A
<ul style="list-style-type: none"> ULTRAGLOSS ULTRAGLOSS EL0 Bianco, EL1 Talpa, EL2 Lino 	4	A
<ul style="list-style-type: none"> LACCATO OPACO MATT LACQUER 010 Bianco, 000 Panna, 001 Crema, 002 Grigio Perla, 003 Grigio Seta, 004 Corda, 005 Moka, 006 Blu Cobalto, 007 Grigio Aston, 008 Grigio Antracite, 009 Nero 	5	A
<ul style="list-style-type: none"> LACCATO LUCIDO GLOSSY LACQUERED L10 Bianco, L00 Panna, L01 Crema, L02 Grigio Perla, L03 Grigio Seta, L04 Corda, L05 Moka, L06 Blu Cobalto, L07 Grigio Aston, L08 Grigio Antracite, L09 Nero 	6	A
<ul style="list-style-type: none"> FENIX NTM® FENIX NTM® FM0 Bianco Kos, FM1 Beige Arizona, FM2 Castoro Ottawa, FM3 Grigio Londra, FM4 Rosso Jaipur, FM5 Verde Comodoro, FM6 Nero Ingo 	5	A
<ul style="list-style-type: none"> LACCATO METALLO LACQUERED METAL L00 Ottone, L01 Acciaio, L02 Bronzo LS0 Oro, LS1 Ottone, LS2 Bronzo scuro, LS3 Titanio LA0 Ottone, LA1 Bronzo scuro, LA2 Silicio 	5	A
<ul style="list-style-type: none"> ESSENZA 1 WOOD 1 ER0 Rovere Visone, ER1 Rovere Castoro, ER2 Rovere Carbone, ER3 Rovere Cenere 	8	A
<ul style="list-style-type: none"> ESSENZA 2 WOOD 2 EE0 Noce Canaletto, EE1 Rovere Termotrattato 	8	B

SPALLE

Side panels
Côtés
Laterales
Aussenseiten

Spalla materico sp. 1,8 cm con due lati a vista e bordo ABS (prezzi al metro lineare)

Textured side panel 1.8 cm thick with two exposed sides and ABS edge (prices per linear metre)
Support texturé de 1,8 cm d'épaisseur avec deux faces visibles et bord en ABS (prix par mètre linéaire)
Soporte texturizado de 1,8 cm de grosor con dos caras visibles y borde de ABS (precios por metro lineal)
1,8 cm dicke, strukturierte Rückseite mit zwei sichtbaren Seiten und ABS-Kante (Preise pro Laufmeter)

Altezza massima 278 cm
Maximum height 278 cm
Hauteur maximale 278 cm
Altura máxima 278 cm
Maximale Höhe 278 cm



P/D	CODICE	PUNTI A	PUNTI B
37	KSN01180372LA	29	-
37	KSN01180372LB	-	36
60	KSN01180602LA	47	-
60	KSN01180602LB	-	58
65	KSN01180652LA	51	-
65	KSN01180652LB	-	63
70	KSN01180702LA	51	-
70	KSN01180702LB	-	68
75	KSN01180752LA	59	-
75	KSN01180752LB	-	73
97	KSN02180972LA	76	-
97	KSN02180972LB	-	94
107	KSN02181072LA	84	-
107	KSN02181072LB	-	104
120	KSN02181202LA	95	-
120	KSN02181202LB	-	116
130	KSN02181302LA	102	-
130	KSN02181302LB	-	126

Kit 2 piedini PUNTI 30 COD. KMAGSN142

Kit 2 feet | Kit 2 pieds | Kit 2 pies | Bausatz 2 FüÙe

Kit 3 piedini PUNTI 45 COD. KMAGSN147

3 feet kit | Kit de 3 pieds | Kit de 3 pies | 3-FuÙ-Bausatz

Basi con maniglia
Base units with handle

Basi con gola
Base units with groove

Colonne
Tall units

Pensili
Wall units

Elementi speciali
Special elements

Maniglie gole zoccoli
Handles grooves plinth

Illuminazione
Lighting

Accessori
Accessories

Componenti e meccanismi
Components e mechanism

SPALLE

Side panels
Côtés
Laterales
Aussenseiten

Spalla materico sp. 2,2 cm con due lati a vista e bordo ABS (prezzi al metro lineare)

Textured side panel 2.2 cm thick with two exposed sides and ABS edge (prices per linear metre)

Support texturé de 2,2 cm d'épaisseur avec deux faces visibles et un bord en ABS (prix par mètre linéaire)

Soporte texturizado de 2,2 cm de grosor con dos caras visibles y borde de ABS (precios por metro lineal)

2,2 cm dicke, strukturierte Rückseite mit zwei sichtbaren Seiten und ABS-Kante (Preise pro Laufmeter)

Altezza massima 278 cm

Maximum height 278 cm

Hauteur maximale 278 cm

Altura máxima 278 cm

Maximale Höhe 278 cm



P/D	CODICE	PUNTI A	PUNTI B
37	KSN01220372LA	31	-
37	KSN01220372LB	-	38
60	KSN01220602LA	50	-
60	KSN01220602LB	-	61
65	KSN01220652LA	54	-
65	KSN01220652LB	-	66
70	KSN01220702LA	58	-
70	KSN01220702LB	-	71
75	KSN01220752LA	62	-
75	KSN01220752LB	-	76
97	KSN02220972LA	80	-
97	KSN02220972LB	-	99
107	KSN02221072LA	89	-
107	KSN02221072LB	-	109
120	KSN02221202LA	99	-
120	KSN02221202LB	-	122
130	KSN02221302LA	108	-
130	KSN02221302LB	-	133

Kit 2 piedini PUNTI 30 COD. K MAGSN142

Kit 2 feet | Kit 2 pieds | Kit 2 pies | Bausatz 2 Füße

Kit 3 piedini PUNTI 45 COD. K MAGSN147

3 feet kit | Kit de 3 pieds | Kit de 3 pies | 3-Fuß-Bausatz

Spalla materico sp. 2,2 cm con due lati a vista e bordo ABS, per gola verticale terminale con staffe fissaggio incluse (prezzi al metro lineare)

2.2 cm thick textured side panel with two exposed sides and ABS edge, for vertical end groove with fixing brackets included (prices per linear metre)

Support en matériau de 2,2 cm d'épaisseur avec deux faces visibles et bord en ABS, pour rainure d'extrémité verticale avec pattes de fixation incluses (prix par mètre linéaire)

Soporte de material de 2,2 cm de grosor con dos caras visibles y borde de ABS, para ranura final vertical con soportes de fijación incluidos (precios por metro lineal)

2,2 cm dicke Materialrückseite mit zwei Sichtseiten und ABS-Kante, für vertikale Abschlussrille mit Befestigungswinkeln im Lieferumfang (Preise pro Laufmeter)

Altezza massima 278 cm

Maximum height 278 cm

Hauteur maximale 278 cm

Altura máxima 278 cm

Maximale Höhe 278 cm



P/D	CODICE	PUNTI A	PUNTI B
37	KSN03220372LA	37	-
37	KSN03220372LB	-	44
60	KSN03220602LA	56	-
60	KSN03220602LB	-	68
65	KSN03220652LA	60	-
65	KSN03220652LB	-	73
70	KSN03220702LA	65	-
70	KSN03220702LB	-	78
75	KSN03220752LA	69	-
75	KSN03220752LB	-	83

Kit 2 piedini PUNTI 30 COD. K MAGSN142

Kit 2 feet | Kit 2 pieds | Kit 2 pies | Bausatz 2 Füße

Kit 3 piedini PUNTI 45 COD. K MAGSN147

3 feet kit | Kit de 3 pieds | Kit de 3 pies | 3-Fuß-Bausatz

SPALLE

Side panels
Côtés
Laterales
Aussenseiten

Spalla Ultramat sp. 2,2 cm con un lato a vista e bordo ABS (prezzi al metro lineare)

Ultramat side panel 2,2 cm thick with one side exposed and ABS edge (prices per linear metre)
Ultramat de 2,2 cm d'épaisseur avec une face visible et un bord en ABS (prix par mètre linéaire)
Ultramat de 2,2 cm de grosor con una cara visible y borde de ABS (precios por metro lineal)
2,2 cm dicke Ultramat mit einer Sichtseite und ABS-Kante (Preise pro Laufmeter)

Altezza massima 278 cm
Maximum height 278 cm
Hauteur maximale 278 cm
Altura máxima 278 cm
Maximale Höhe 278 cm



P/D	CODICE	PUNTI A
37	KSE01220372LA	44
60	KSE01220602LA	71
65	KSE01220652LA	77
70	KSE01220702LA	83
75	KSE01220752LA	89
97	KSE02220972LA	115
107	KSE02221072LA	127
120	KSE02221202LA	143

Kit 2 piedini PUNTI 30 COD. KMAGSE142

Kit 2 feet | Kit 2 pieds | Kit 2 pies | Bausatz 2 Füße

Kit 3 piedini PUNTI 45 COD. KMAGSE147

3 feet kit | Kit de 3 pieds | Kit de 3 pies | 3-Fuß-Bausatz

Spalla Ultramat sp. 2,2 cm con un lato a vista e bordo ABS, per gola verticale terminale con staffe fissaggio incluse (prezzi al metro lineare)

Ultramat side panel 2,2 cm thick with one exposed side and ABS edge, for vertical end groove with fixing brackets included (prices per linear metre)
Ultramat de 2,2 cm d'épaisseur avec une face visible et un bord en ABS, pour rainure d'extrémité verticale avec supports de fixation inclus (prix par mètre linéaire)
Ultramat de 2,2 cm de grosor con una cara visible y borde de ABS, para ranura final vertical con soportes de fijación incluidos (precios por metro lineal)
2,2 cm dicke Ultramat mit einer Sichtseite und ABS-Kante, für vertikale Abschlussrinne mit Befestigungswinkeln im Lieferumfang (Preise pro Laufmeter)

Altezza massima 278 cm
Maximum height 278 cm
Hauteur maximale 278 cm
Altura máxima 278 cm
Maximale Höhe 278 cm



P/D	CODICE	PUNTI A
37	KSE03220372LA	51
60	KSE03220602LA	78
65	KSE03220652LA	84
70	KSE03220702LA	90
75	KSE03220752LA	96

Kit 2 piedini PUNTI 30 COD. KMAGSE142

Kit 2 feet | Kit 2 pieds | Kit 2 pies | Bausatz 2 Füße

Kit 3 piedini PUNTI 45 COD. KMAGSE147

3 feet kit | Kit de 3 pieds | Kit de 3 pies | 3-Fuß-Bausatz

Basi con maniglia
Base units with handle

Basi con gola
Base units with groove

Colonne
Tall units

Pensili
Wall units

Elementi speciali
Special elements

Maniglie gole zoccoli
Handles grooves plinth

Illuminazione
Lighting

Accessori
Accessories

Componenti e meccanismi
Components e mechanism

SPALLE

Side panels
Côtés
Laterales
Aussenseiten

Spalla Ultragloss sp. 2,2 cm con un lato a vista e bordo ABS (prezzi al metro lineare)

Ultragloss side panel 1 side exposed 2,2 cm thick with ABS edge (prices per linear metre)

Ultragloss 1 face de 2,2 cm d'épaisseur avec bord en ABS (prix par mètre linéaire)

1 cara Ultragloss de 2,2 cm de grosor con borde de ABS (precios por metro lineal)

1-seitig Ultragloss 2,2 cm dick mit ABS-Kante (Preise pro Laufmeter)

Altezza massima 278 cm

Maximum height 278 cm

Hauteur maximale 278 cm

Altura máxima 278 cm

Maximale Höhe 278 cm



P/D	CODICE	PUNTI A
37	KSG01220372LA	144
60	KSG01220602LA	234
65	KSG01220652LA	254
70	KSG01220702LA	273
75	KSG01220752LA	293
97	KSG02220972LA	379
107	KSG02221072LA	418
120	KSG02221202LA	469

Kit 2 piedini PUNTI 30 COD. KMAGSG142

Kit 2 feet | Kit 2 pieds | Kit 2 pies | Bausatz 2 Füße

Kit 3 piedini PUNTI 45 COD. KMAGSG147

3 feet kit | Kit de 3 pieds | Kit de 3 pies | 3-Fuß-Bausatz

Spalla Ultragloss sp. 2,2 cm con un lato a vista e bordo ABS, per gola verticale terminale con staffe fissaggio incluse (prezzi al metro lineare)

Ultragloss side panel 2 cm thick with one side exposed and ABS edge, for vertical end groove with fixing brackets included (prices per linear metre)

2,2 cm d'épaisseur Ultragloss avec une face visible et un bord ABS, pour rainure d'extrémité verticale avec supports de fixation inclus (prix par mètre linéaire)

2,2 cm de grosor Ultragloss con una cara visible y borde ABS, para ranura final vertical con soportes de fijación incluidos (precios por metro lineal)

2,2 cm starkes Ultragloss mit einer Sichtseite und ABS-Kante, für vertikale Endrinne mit Befestigungswinkeln im Lieferumfang (Preise pro Laufmeter)

Altezza massima 278 cm

Maximum height 278 cm

Hauteur maximale 278 cm

Altura máxima 278 cm

Maximale Höhe 278 cm



P/D	CODICE	PUNTI A
37	KSG03220372LA	151
60	KSG03220602LA	241
65	KSG03220652LA	260
70	KSG03220702LA	280
75	KSG03220752LA	300

Kit 2 piedini PUNTI 30 COD. KMAGSG142

Kit 2 feet | Kit 2 pieds | Kit 2 pies | Bausatz 2 Füße

Kit 3 piedini PUNTI 45 COD. KMAGSG147

3 feet kit | Kit de 3 pieds | Kit de 3 pies | 3-Fuß-Bausatz

SPALLE

Side panels
Côtés
Laterales
Aussenseiten

Spalla Laccato Opaco sp. 2,2 cm con due lati a vista (prezzi al metro lineare)

Matt lacquered side panel 2,2 cm thick with two exposed sides (prices per linear metre)

Laqué mat de 2,2 cm d'épaisseur avec deux faces visibles (prix par mètre linéaire)

Lacado mate de 2,2 cm de grosor con dos caras visibles (precios por metro lineal)

Matt lackiert, 2,2 cm dick, mit zwei sichtbaren Seiten (Preise pro Laufmeter)

Altezza massima 278 cm

Maximum height 278 cm

Hauteur maximale 278 cm

Altura máxima 278 cm

Maximale Höhe 278 cm



P/D	CODICE	PUNTI A
37	KS001220372LA	72
60	KS001220602LA	117
65	KS001220652LA	127
70	KS001220702LA	136
75	KS001220752LA	146
97	KS002220972LA	189
107	KS002221072LA	208
120	KS002221202LA	233
130	KS002221302LA	253

Kit 2 piedini PUNTI 30 COD. KMGAS0142

Kit 2 feet | Kit 2 pieds | Kit 2 pies | Bausatz 2 Füße

Kit 3 piedini PUNTI 45 COD. KMGAS0147

3 feet kit | Kit de 3 pieds | Kit de 3 pies | 3-Fuß-Bausatz

Spalla Laccato Opaco sp. 2,2 cm con due lati a vista, per gola verticale terminale con staffe fissaggio incluse (prezzi al metro lineare)

2,2 cm thick matt lacquered 2-sided face for vertical end groove including fixing brackets (prices per linear metre)

Laqué mat 2,2 cm d'épaisseur 2 côtés pour rainure d'extrémité verticale, y compris les supports de fixation (prix par mètre linéaire)

Lacado mate de 2,2 cm de grosor de 2 caras para ranura de extremo vertical, incluidos los soportes de fijación (precios por metro lineal)

Matt lackiert, 2,2 cm dick, 2-seitig, für vertikale Endrinne, einschließlich Befestigungsklammern (Preise pro Laufmeter)

Altezza massima 278 cm

Maximum height 278 cm

Hauteur maximale 278 cm

Altura máxima 278 cm

Maximale Höhe 278 cm



P/D	CODICE	PUNTI A
37	KS003220372LA	79
60	KS003220602LA	124
65	KS003220652LA	133
70	KS003220702LA	143
75	KS003220752LA	153

Kit 2 piedini PUNTI 30 COD. KMGAS0142

Kit 2 feet | Kit 2 pieds | Kit 2 pies | Bausatz 2 Füße

Kit 3 piedini PUNTI 45 COD. KMGAS0147

3 feet kit | Kit de 3 pieds | Kit de 3 pies | 3-Fuß-Bausatz

Basi con maniglia
Base units with handle

Basi con gola
Base units with groove

Colonne
Tall units

Pensili
Wall units

Elementi speciali
Special elements

Maniglie gole zoccoli
Handles grooves plinth

Illuminazione
Lighting

Accessori
Accessories

Componenti e meccanismi
Components e mechanism

SPALLE

Side panels
Côtés
Laterales
Aussenseiten

Spalla Laccato Opaco sp. 4 cm con due lati a vista (prezzi al metro lineare)

Matt lacquered side panel 2 sides exposed 4 cm thick (prices per linear metre)

Épaupe laquée mat 2 faces 4 cm d'épaisseur (prix par mètre linéaire)

Paleta lacada mate 2 caras 4 cm de grosor (precios por metro lineal)

Schulter Matt lackiert 2-seitig 4 cm dick (Preise pro Laufmeter)

Altezza massima 278 cm

Maximum height 278 cm

Hauteur maximale 278 cm

Altura máxima 278 cm

Maximale Höhe 278 cm

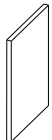

P/D	CODICE	PUNTI A
37	KS001400372LA	89
60	KS001400602LA	143
65	KS001400652LA	155
70	KS001400702LA	167
75	KS001400752LA	179
97	KS002400972LA	231
107	KS002401072LA	254
120	KS002401202LA	285
130	KS002401302LA	309

Kit 2 piedini PUNTI 30 COD. KMAGS0142

Kit 2 feet | Kit 2 pieds | Kit 2 pies | Bausatz 2 Füße

Kit 3 piedini PUNTI 45 COD. KMAGS0147

3 feet kit | Kit de 3 pieds | Kit de 3 pies | 3-Fuß-Bausatz

SPALLE

Side panels
Côtés
Laterales
Aussenseiten

Spalla laminato sp. 2 cm con due lati a vista e bordo Fenix (prezzi al metro lineare)

Laminated side panel 2 cm thick with two exposed sides and Fenix edge (prices per linear metre)
Support stratifié de 2 cm d'épaisseur avec deux faces visibles et bord Fenix (prix par mètre linéaire)
Soporte laminado de 2 cm de grosor con dos caras visibles y borde Fenix (precios por metro lineal)
2 cm starke Laminatrückseite mit zwei sichtbaren Seiten und Fenix-Kante (Preise pro Laufmeter)

Altezza massima 300 cm
Maximum height 300 cm
Hauteur maximale 300 cm
Altura máxima 300 cm
Maximale Höhe 300 cm



P/D	CODICE	PUNTI A
37	KSF01200372LA	270
60	KSF01200602LA	270
65	KSF01200652LA	317
70	KSF01200702LA	317
75	KSF01200752LA	343
97	KSF02200972LA	399
107	KSF02201072LA	450
120	KSF02201202LA	450
125	KSF02201252LA	483

Testa a vista per spalla prof. 37/60/65/70/75 cm (lavorazione obbligatoria da sommare) cad. PUNTI 58 COD. KMGASF138

Terminal edge for side panel 37/60/65/70/75 cm depth (compulsory machining to add up) | Bordure de raccordement pour une profondeur du panneau latéral de 37/60/65/70/75 cm (traitement obligatoire à ajouter) | Borde terminal para para profundidad de lateral 37/60/65/70/75 cm (tratamiento obligatorio a añadir) | Abschlusskante für Seitenwand 37/60/65/70/75 cm Tiefe (obligatorische Bearbeitung)

Testa a vista per spalla prof. 97/107/120/125 cm (lavorazione obbligatoria da sommare) cad. PUNTI 75 COD. KMGASF139

Terminal edge for side panel 97/107/120/125 cm depth (compulsory machining to add up) | Bordure de raccordement pour une profondeur du panneau latéral de 97/107/120/125 cm (travail obligatoire à ajouter) | Borde terminal para para profundidad de lateral 97/107/120/125 cm (trabajo obligatorio a añadir) | Abschlusskante für Seitenwand 97/107/120/125 cm Tiefe (obligatorische Arbeit, die hinzugefügt werden muss)

Kit 2 piedini PUNTI 52 COD. KMGASF142

Kit 2 feet | Kit 2 pieds | Kit 2 pies | Bausatz 2 FüÙe

Kit 3 piedini PUNTI 78 COD. KMGASF147

3 feet kit | Kit de 3 pieds | Kit de 3 pies | 3-Fuß-Bausatz

Predisposizione di centraggio su spalla cad. PUNTI 50 COD. KMGASF168

Centering arrangement on side panel | Dispositif de centrage de l'épaulement | Disposición de centrado del lateral | Zentrieranordnung auf der Seitenwand

Spalla laminato sp. 2 cm con due lati a vista e bordo ABS, per gola verticale terminale con staffe fissaggio incluse (prezzi al metro lineare)

Laminated side panel 2 cm thick with two exposed sides and ABS edge, for vertical end groove with fixing brackets included (prices per linear metre)
Support stratifié de 2 cm d'épaisseur avec deux faces visibles et bord en ABS, pour rainure d'extrémité verticale avec pattes de fixation incluses (prix par mètre linéaire)
Soporte laminado de 2 cm de grosor con dos caras visibles y borde de ABS, para ranura final vertical con soportes de fijación incluidos (precios por metro lineal)
2 cm dicke Laminatrückwand mit zwei sichtbaren Seiten und ABS-Kante, für vertikale Endrinne mit mitgelieferten Befestigungswinkeln (Preise pro Laufmeter)

Altezza massima 278 cm
Maximum height 278 cm
Hauteur maximale 278 cm
Altura máxima 278 cm
Maximale Höhe 278 cm



P/D	CODICE	PUNTI A
37	KSF03200372LA	275
60	KSF03200602LA	275
65	KSF03200652LA	322
70	KSF03200702LA	322
75	KSF03200752LA	348

Testa a vista per spalla prof. 37/60/65/70/75 cm (lavorazione obbligatoria da sommare) cad. PUNTI 58 COD. KMGASF138

Terminal edge for side panel 37/60/65/70/75 cm depth (compulsory machining to add up) | Bordure de raccordement pour une profondeur du panneau latéral de 37/60/65/70/75 cm (traitement obligatoire à ajouter) | Borde terminal para para profundidad de lateral 37/60/65/70/75 cm (tratamiento obligatorio a añadir) | Abschlusskante für Seitenwand 37/60/65/70/75 cm Tiefe (obligatorische Bearbeitung)

Testa a vista per spalla prof. 97/107/120/125 cm (lavorazione obbligatoria da sommare) cad. PUNTI 75 COD. KMGASF139

Terminal edge for side panel 97/107/120/125 cm depth (compulsory machining to add up) | Bordure de raccordement pour une profondeur du panneau latéral de 97/107/120/125 cm (travail obligatoire à ajouter) | Borde terminal para para profundidad de lateral 97/107/120/125 cm (trabajo obligatorio a añadir) | Abschlusskante für Seitenwand 97/107/120/125 cm Tiefe (obligatorische Arbeit, die hinzugefügt werden muss)

Kit 2 piedini PUNTI 52 COD. KMGASF142

Kit 2 feet | Kit 2 pieds | Kit 2 pies | Bausatz 2 FüÙe

Kit 3 piedini PUNTI 78 COD. KMGASF147

3 feet kit | Kit de 3 pieds | Kit de 3 pies | 3-Fuß-Bausatz

Predisposizione di centraggio su spalla cad. PUNTI 50 COD. KMGASF168

Centering arrangement on side panel | Dispositif de centrage de l'épaulement | Disposición de centrado del lateral | Zentrieranordnung auf der Seitenwand

Basi con maniglia
Base units with handle

Basi con gola
Base units with groove

Colonne
Tall units

Pensili
Wall units

Elementi speciali
Special elements

Maniglie gole zoccoli
Handles grooves plinth

Illuminazione
Lighting

Accessori
Accessories

Componenti e meccanismi
Components e mechanism

SPALLE

Side panels
Côtés
Laterales
Aussenseiten

Spalla laminato sp. 4 cm con due lati a vista e bordo Fenix (prezzi al metro lineare)

Laminated side panel 4 cm thick with two exposed sides and Fenix edge (prices per linear metre)
Support stratifié de 4 cm d'épaisseur avec deux faces visibles et bord Fenix (prix par mètre linéaire)
Soporte laminado de 4 cm de grosor con dos caras visibles y borde Fenix (precios por metro lineal)
4 cm starke Laminatrückseite mit zwei sichtbaren Seiten und Fenix-Kante (Preise pro Laufmeter)

Altezza massima 300 cm
Maximum height 300 cm
Hauteur maximale 300 cm
Altura máxima 300 cm
Maximale Höhe 300 cm



P/D	CODICE	PUNTI A
37	KSF01400372LA	308
60	KSF01400602LA	308
65	KSF01400652LA	360
70	KSF01400702LA	360
75	KSF01400752LA	389
97	KSF02400972LA	453
107	KSF02401072LA	514
120	KSF02401202LA	514
125	KSF02401252LA	553

Testa a vista per spalla prof. 37/60/65/70/75 cm (lavorazione obbligatoria da sommare) cad. PUNTI 58 COD. KMAGSF138

Terminal edge for side panel 37/60/65/70/75 cm depth (compulsory machining to add up) | Bordure de raccordement pour une profondeur du panneau latéral de 37/60/65/70/75 cm (traitement obligatoire à ajouter) | Borde terminal para para profundidad de lateral 37/60/65/70/75 cm (tratamiento obligatorio a añadir) | Abschlusskante für Seitenwand 37/60/65/70/75 cm Tiefe (obligatorische Bearbeitung)

Testa a vista per spalla prof. 97/107/120/125 cm (lavorazione obbligatoria da sommare) cad. PUNTI 75 COD. KMAGSF139

Terminal edge for side panel 97/107/120/125 cm depth (compulsory machining to add up) | Bordure de raccordement pour une profondeur du panneau latéral de 97/107/120/125 cm (travail obligatoire à ajouter) | Borde terminal para para profundidad de lateral 97/107/120/125 cm (trabajo obligatorio a añadir) | Abschlusskante für Seitenwand 97/107/120/125 cm Tiefe (obligatorische Arbeit, die hinzugefügt werden muss)

Kit 2 piedini PUNTI 52 COD. KMAGSF142

Kit 2 feet | Kit 2 pieds | Kit 2 pies | Bausatz 2 Füße

Kit 3 piedini PUNTI 78 COD. KMAGSF147

3 feet kit | Kit de 3 pieds | Kit de 3 pies | 3-Fuß-Bausatz

Predisposizione di centraggio su spalla cad. PUNTI 50 COD. KMAGSF168

Centering arrangement on side panel | Dispositif de centrage de l'épaulement | Disposición de centrado del lateral | Zentrieranordnung auf der Seitenwand

Spalla Fenix stratificato sp. 1,2 cm con due lati a vista (prezzi al metro lineare)

Laminated Fenix side panel 1.2 cm thick with two exposed sides (prices per linear metre)
Panneau latéral Fenix de 1,2 cm d'épaisseur avec deux faces visibles (prix par mètre linéaire)
Panel lateral Fenix estratificado de 1,2 cm de grosor con dos caras visibles (precios por metro lineal)
1,2 cm dicke, geschichtete Fenix-Seitenwand mit zwei sichtbaren Seiten (Preise pro Laufmeter)

Altezza massima 300 cm
Maximum height 300 cm
Hauteur maximale 300 cm
Altura máxima 300 cm
Maximale Höhe 300 cm

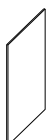

P/D	CODICE	PUNTI A
37	KSS05120372LA	439
60	KSS05120602LA	439
65	KSS05120652LA	505
70	KSS05120702LA	505
75	KSS05120752LA	577
97	KSS06120972LA	721
107	KSS06121072LA	865
120	KSS06121202LA	865
125	KSS06121252LA	930

SPALLE

Side panels
Côtés
Laterales
Aussenseiten

Spalla Laccato Lucido sp. 2,2 cm con due lati a vista (prezzi al metro lineare)

Glossy Lacquered side panel 2.2 cm thick with two exposed sides (prices per linear metre)
Panneau latéral laqué brillant de 2,2 cm d'épaisseur avec deux faces visibles (prix par mètre linéaire)
Panel lateral lacado brillante de 2,2 cm de grosor con dos caras visibles (precios por metro lineal)
2,2 cm dicke, glänzend lackierte Seitenwand mit zwei sichtbaren Seiten (Preise pro Laufmeter)

Altezza massima 278 cm
Maximum height 278 cm
Hauteur maximale 278 cm
Altura máxima 278 cm
Maximale Höhe 278 cm



P/D	CODICE	PUNTI A
37	KS004220372LA	166
60	KS004220602LA	270
65	KS004220652LA	292
70	KS004220702LA	314
75	KS004220752LA	337
97	KS005220972LA	435
107	KS005221072LA	480
120	KS005221202LA	538
130	KS005221302LA	583

Kit 2 piedini PUNTI 30 COD. KMGAS0142

Kit 2 feet | Kit 2 pieds | Kit 2 pies | Bausatz 2 Füße

Kit 3 piedini PUNTI 45 COD. KMGAS0147

3 feet kit | Kit de 3 pieds | Kit de 3 pies | 3-Fuß-Bausatz

Spalla Laccato Lucido sp. 2,2 cm con due lati a vista, per gola verticale terminale con staffe fissaggio incluse (prezzi al metro lineare)

Glossy Lacquered side panel 2.2 cm thick with two exposed sides, for vertical end groove with fixing brackets included (prices per linear metre)
Panneau latéral laqué brillant de 2,2 cm d'épaisseur avec deux côtés visibles, pour rainure d'extrémité verticale avec supports de fixation inclus (prix par mètre linéaire)
Panel lateral lacado brillante de 2,2 cm de grosor con dos caras visibles, para ranura final vertical con soportes de fijación incluidos (precios por metro lineal)
2,2 cm dicke, glänzend lackierte Seitenwand mit zwei sichtbaren Seiten, für vertikale Endrinne mit mitgelieferten Befestigungswinkeln (Preise pro Laufmeter)

Altezza massima 278 cm
Maximum height 278 cm
Hauteur maximale 278 cm
Altura máxima 278 cm
Maximale Höhe 278 cm



P/D	CODICE	PUNTI A
37	KS006220372LA	173
60	KS006220602LA	276
65	KS006220652LA	299
70	KS006220702LA	321
75	KS006220752LA	343

Kit 2 piedini PUNTI 30 COD. KMGAS0142

Kit 2 feet | Kit 2 pieds | Kit 2 pies | Bausatz 2 Füße

Kit 3 piedini PUNTI 45 COD. KMGAS0147

3 feet kit | Kit de 3 pieds | Kit de 3 pies | 3-Fuß-Bausatz

Basi con maniglia
Base units with handle

Basi con gola
Base units with groove

Colonne
Tall units

Pensili
Wall units

Elementi speciali
Special elements

Maniglie gole zoccoli
Handles grooves plinth

Illuminazione
Lighting

Accessori
Accessories

Componenti e meccanismi
Components e mechanism

SPALLE

Side panels
Côtés
Laterales
Aussenseiten

Spalla Laccato Lucido sp. 4 cm con due lati a vista (prezzi al metro lineare)

Glossy Lacquered side panel 4 cm thick with two exposed sides (prices per linear metre)
Panneau latéral laqué brillant de 4 cm d'épaisseur avec deux faces visibles (prix par mètre linéaire)
Panel lateral lacado brillante de 4 cm de grosor con dos caras visibles (precios por metro lineal)
4 cm dicke, glänzend lackierte Seitenwand mit zwei sichtbaren Seiten (Preise pro Laufmeter)

Altezza massima 278 cm
Maximum height 278 cm
Hauteur maximale 278 cm
Altura máxima 278 cm
Maximale Höhe 278 cm

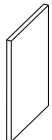

P/D	CODICE	PUNTI A
37	KS004400372LA	183
60	KS004400602LA	296
65	KS004400652LA	320
70	KS004400702LA	345
75	KS004400752LA	369
97	KS005400972LA	477
107	KS005401072LA	526
120	KS005401202LA	590
130	KS005401302LA	639

Kit 2 piedini PUNTI 30 COD. KMAGS0142

Kit 2 feet | Kit 2 pieds | Kit 2 pies | Bausatz 2 Füße

Kit 3 piedini PUNTI 45 COD. KMAGS0147

3 feet kit | Kit de 3 pieds | Kit de 3 pies | 3-Fuß-Bausatz

SPALLE

Side panels
Côtés
Laterales
Aussenseiten

Spalla Laccato Metallo sp. 2,2 cm con due lati a vista (prezzi al metro lineare)

Metal lacquered side panel 2.2 cm thick with two exposed sides (prices per linear metre)
Métal laqué de 2,2 cm d'épaisseur avec deux faces visibles (prix par mètre linéaire)
Metal lacado de 2,2 cm de grosor con dos caras visibles (precios por metro lineal)
2,2 cm dickes, lackiertes Metall mit zwei sichtbaren Seiten (Preise pro Laufmeter)

Altezza massima 278 cm
Maximum height 278 cm
Hauteur maximale 278 cm
Altura máxima 278 cm
Maximale Höhe 278 cm



P/D	CODICE	PUNTI A
37	KS007220372LA	203
60	KS007220602LA	329
65	KS007220652LA	357
70	KS007220702LA	384
75	KS007220752LA	412
97	KS008220972LA	533
107	KS008221072LA	585
120	KS008221202LA	659

Kit 2 piedini PUNTI 30 COD. KMGAS0142

Kit 2 feet | Kit 2 pieds | Kit 2 pies | Bausatz 2 FüÙe

Kit 3 piedini PUNTI 45 COD. KMGAS0147

3 feet kit | Kit de 3 pieds | Kit de 3 pies | 3-Fuß-Bausatz

Spalla Laccato Metallo sp. 2,2 cm con due lati a vista, per gola verticale terminale con staffe fissaggio incluse (prezzi al metro lineare)

Metal lacquered side panel 2.2 cm thick with two exposed sides, for vertical end groove with fixing brackets included (prices per linear metre)
Métal laqué de 2,2 cm d'épaisseur avec deux faces visibles, pour rainure d'extrémité verticale avec pattes de fixation incluses (prix par mètre linéaire)
Metal lacado de 2,2 cm de grosor con dos caras visibles, para ranura final vertical con soportes de fijación incluidos (precios por metro lineal)
2,2 cm dickes, lackiertes Metall mit zwei sichtbaren Seiten, für vertikale Endrinne mit mitgelieferten Befestigungswinkeln (Preise pro Laufmeter)

Altezza massima 278 cm
Maximum height 278 cm
Hauteur maximale 278 cm
Altura máxima 278 cm
Maximale Höhe 278 cm



P/D	CODICE	PUNTI A
37	KS009220372LA	208
60	KS009220602LA	334
65	KS009220652LA	362
70	KS009220702LA	389
75	KS009220752LA	416

Basi con maniglia
Base units with handle

Basi con gola
Base units with groove

Colonne
Tall units

Pensili
Wall units

Elementi speciali
Special elements

Maniglie gole zoccoli
Handles grooves plinth

Illuminazione
Lighting

Accessori
Accessories

Componenti e meccanismi
Components e mechanism

SPALLE

Side panels
Épaules
Hombros
Schultern

Spalla Laccato Metallo sp. 4 cm con due lati a vista (prezzi al metro lineare)

Metal lacquered side panel 4 cm thick with two exposed sides (prices per linear metre)

Métal laqué de 4 cm d'épaisseur avec deux faces visibles (prix par mètre linéaire)

Metal lacado de 4 cm de grosor con dos caras visibles (precios por metro lineal)

Lackiertes Metall 4 cm dick mit zwei sichtbaren Seiten (Preise pro Laufmeter)

Altezza massima 278 cm

Maximum height 278 cm

Hauteur maximale 278 cm

Altura máxima 278 cm

Maximale Höhe 278 cm

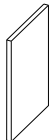

P/D	CODICE	PUNTI A
37	KS007400372LA	239
60	KS007400602LA	387
65	KS007400652LA	419
70	KS007400702LA	452
75	KS007400752LA	484
97	KS008400972LA	626
107	KS008401072LA	690
120	KS008401202LA	774

Kit 2 piedini PUNTI 30 COD. KMAGS0142

Kit 2 feet | Kit 2 pieds | Kit 2 pies | Bausatz 2 Füße

Kit 3 piedini PUNTI 45 COD. KMAGS0147

3 feet kit | Kit de 3 pieds | Kit de 3 pies | 3-Fuß-Bausatz

SPALLE

Side panels
Epaules
Hombros
Schultern

Spalla Essenza sp. 2,2 cm con due lati a vista e bordo impiallacciato (prezzi al metro lineare)

Wooden side panel 2,2 cm thick with two exposed sides and veneer edge (prices per linear metre)

Panneau latéral en bois de 2,2 cm d'épaisseur avec deux faces visibles et un bord plaqué (prix par mètre linéaire)

Panel lateral de madera de 2,2 cm de grosor con dos caras visibles y borde chapado (precios por metro lineal)

Seitenwand aus Holz 2,2 cm dick mit zwei sichtbaren Seiten und furniertem Rand (Preise pro Laufmeter)



Altezza massima 300 cm Altezza minima fatturabile 1 ml
Maximum height 300 cm Minimum billable height 1 ml
Hauteur maximale 300 cm Hauteur minimale facturable 1 ml
Altura máxima 300 cm Altura mínima facturable 1 ml
Maximale Höhe 300 cm Minimale abrechenbare Höhe 1 ml

P/D	CODICE	PUNTI A	PUNTI B
37	KSI01220372LA	280	-
37	KSI01220372LB	-	291
60	KSI01220602LA	409	-
60	KSI01220602LB	-	427
65	KSI01220652LA	437	-
65	KSI01220652LB	-	456
70	KSI01220702LA	465	-
70	KSI01220702LB	-	486
75	KSI01220752LA	493	-
75	KSI01220752LB	-	515
97	KSI02220972LA	616	-
97	KSI02220972LB	-	645
107	KSI02221072LA	672	-
107	KSI02221072LB	-	704
120	KSI02221202LA	745	-
120	KSI02221202LB	-	781
124	KSI02221242LA	768	-
124	KSI02221242LB	-	805

Testa a vista al metro lineare (lavorazione obbligatoria da sommare) PUNTI 50 COD. KMAAGSI140

Exposed edge per linear meter (compulsory machining to be added) | Bord exposé par mètre linéaire (travaux obligatoires à ajouter)

Borde expuesto por metro lineal (trabajo obligatorio a añadir) | Freiliegende Seite pro laufendem Meter (obligatorische Arbeit, die hinzuzufügen ist)

Kit 2 piedini PUNTI 30 COD. KMAAGSI242

Kit 2 feet | Kit 2 pieds | Kit 2 pies | Bausatz 2 Füße

Kit 3 piedini PUNTI 45 COD. KMAAGSI247

3 feet kit | Kit de 3 pieds | Kit de 3 pies | 3-Fuß-Bausatz

Predisposizione di centraggio su spalla PUNTI 50 COD. KMAAGSI268

Centering arrangement on side panel | Dispositif de centrage de l'épaulement | Disposición de centrado del lateral | Zentrieranordnung auf der Seitenwand

Spalla Essenza sp. 2,2 cm con due lati a vista e bordo impiallacciato, per gola verticale terminale con staffe fissaggio incluse (prezzi al metro lineare)

Wooden side panel 2,2 cm thick with two exposed sides and veneer edge, for vertical end groove with fixing brackets included (prices per linear metre)

Panneau latéral Essenza de 2,2 cm d'épaisseur avec deux côtés visibles et un bord plaqué, pour rainure d'extrémité verticale avec supports de fixation inclus (prix par mètre linéaire)

Panel lateral Essenza de 2,2 cm de grosor con dos lados visibles y borde chapado, para ranura final vertical con soportes de fijación incluidos (precios por metro lineal)

Seitenwand Essenza 2,2 cm dick mit zwei sichtbaren Seiten und furnierter Kante, für vertikale Abschlussnut mit Befestigungswinkel im Lieferumfang (Preise pro Laufmeter)



Altezza massima 278 cm
Maximum height 278 cm
Hauteur maximale 278 cm
Altura máxima 278 cm
Maximale Höhe 278 cm

P/D	CODICE	PUNTI A	PUNTI B
37	KSI03220372LA	285	-
37	KSI03220372LB	-	296
60	KSI03220602LA	414	-
60	KSI03220602LB	-	431
65	KSI03220652LA	442	-
65	KSI03220652LB	-	461
70	KSI03220702LA	470	-
70	KSI03220702LB	-	491
75	KSI03220752LA	498	-
75	KSI03220752LB	-	520

Testa a vista al metro lineare (lavorazione obbligatoria da sommare) PUNTI 50 COD. KMAAGSI140

Exposed edge per linear meter (compulsory machining to be added) | Bord exposé par mètre linéaire (travaux obligatoires à ajouter) | Borde expuesto por metro lineal (trabajo obligatorio a añadir) | Freiliegende Seite pro laufendem Meter (obligatorische Arbeit, die hinzuzufügen ist)

Kit 2 piedini PUNTI 30 COD. KMAAGSI242

Kit 2 feet | Kit 2 pieds | Kit 2 pies | Bausatz 2 Füße

Kit 3 piedini PUNTI 45 COD. KMAAGSI247

3 feet kit | Kit de 3 pieds | Kit de 3 pies | 3-Fuß-Bausatz

Predisposizione di centraggio su spalla PUNTI 50 COD. KMAAGSI268

Centering arrangement on side panel | Dispositif de centrage de l'épaulement | Disposición de centrado del lateral | Zentrieranordnung auf der Seitenwand

Basi con maniglia
Base units with handle

Basi con gola
Base units with groove

Colonne
Tall units

Pensili
Wall units

Elementi speciali
Special elements

Maniglie gole zoccoli
Handles grooves plinth

Illuminazione
Lighting

Accessori
Accessories

Componenti e meccanismi
Components e mechanism

SPALLE

Side panels
Côtés
Laterales
Aussenseiten

Spalla Essenza sp. 4 cm con due lati a vista e bordo impiallacciato (prezzi al metro lineare)

Wooden side panel 4 cm thick with two exposed sides and veneer edge (prices per linear metre)
Epaule Essenza 4 cm d'épaisseur avec deux faces visibles et bord plaqué (prix par mètre linéaire)
Paleta Essenza de 4 cm de grosor con dos lados visibles y borde chapado (precios por metro lineal)
Schulter Essenza 4 cm dick mit zwei sichtbaren Seiten und furniertem Rand (Preise pro Laufmeter)

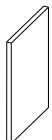

Altezza massima 300 cm Altezza minima fatturabile 1 ml
Maximum height 300 cm Minimum billable height 1 ml
Hauteur maximale 300 cm Hauteur minimale facturable 1 ml
Altura máxima 300 cm Altura mínima facturable 1 ml
Maximale Höhe 300 cm Minimale abrechenbare Höhe 1 ml

P/D	CODICE	PUNTI A	PUNTI B
37	KSI01400372LA	313	-
37	KSI01400372LB	-	324
60	KSI01400602LA	452	-
60	KSI01400602LB	-	470
65	KSI01400652LA	482	-
65	KSI01400652LB	-	501
70	KSI01400702LA	512	-
70	KSI01400702LB	-	533
75	KSI01400752LA	542	-
75	KSI01400752LB	-	565
97	KSI02400972LA	675	-
97	KSI02400972LB	-	704
107	KSI02401072LA	735	-
107	KSI02401072LB	-	767
120	KSI02401202LA	814	-
120	KSI02401202LB	-	850
124	KSI02401242LA	838	-
124	KSI02401242LB	-	875

Testa a vista al metro lineare (lavorazione obbligatoria da sommare) PUNTI 63 COD. KMAGSI140

Exposed edge per linear meter (compulsory machining to be added) | Bord exposé par mètre linéaire (travaux obligatoires à ajouter) |
Borde expuesto por metro lineal (trabajo obligatorio a añadir) | Freiliegende Seite pro laufendem Meter (obligatorische Arbeit, die hinzuzufügen ist)

Kit 2 piedini PUNTI 30 COD. KMAGSI242

Kit 2 feet | Kit 2 pieds | Kit 2 pies | Bausatz 2 Füße

Kit 3 piedini PUNTI 45 COD. KMAGSI247

3 feet kit | Kit de 3 pieds | Kit de 3 pies | 3-Fuß-Bausatz

Predisposizione di centraggio su spalla PUNTI 150 COD. KMAGSI268

Centering arrangement on side panel | Dispositif de centrage de l'épaulement | Disposición de centrado del lateral | Zentrieranordnung auf der Seitenwand

PANNELLI

Panels
Panneaux
Paneles
Paneele

Il pannello si usa in abbinamento alle ante. I pannelli possono essere utilizzati come pannelli retrobase o come spalle di finitura a terra. In entrambi i casi è consigliato aggiungere i piedini regolabili in altezza che permettono una regolazione di 0,5 cm. Il pannello, se utilizzato come retrobase, prevede un kit per il fissaggio. Il pannello deve essere agganciato prima di posizionare il piano sopra le basi.

The panel is used in conjunction with the doors. The panels can be used as back panels or as floor finish side panels. In both cases, it is recommended to add the height-adjustable feet that allow 0.5 cm adjustment. The panel, when used as a back-base, includes an attachment kit. The panel must be attached before placing the top on top of the bases.

Le panneau est utilisé en combinaison avec les portes. Les panneaux peuvent être utilisés comme panneaux de fond ou comme épaulements de finition du sol. Dans les deux cas, il est recommandé d'ajouter les pieds réglables en hauteur, qui permettent un ajustement de 0,5 cm. Le panneau, lorsqu'il est utilisé comme base arrière, nécessite un kit de fixation. Le panneau doit être fixé avant de positionner le plateau au-dessus des éléments de base.

El panel se utiliza en combinación con las puertas. Los paneles pueden utilizarse como paneles traseros o como laterales de acabado de suelo. En ambos casos, se recomienda añadir los pies regulables en altura, que permiten un ajuste de 0,5 cm. El panel, cuando se utiliza como respaldo, requiere un kit de fijación. El panel debe fijarse antes de colocar la encimera sobre los muebles bajos.

Das Paneel wird in Kombination mit den Türen verwendet. Die Paneele können als Rückwand oder als Bodenabschluss-Seitenteile verwendet werden. In beiden Fällen empfiehlt es sich, die höhenverstellbaren Füße hinzuzufügen, die eine Verstellung von 0,5 cm ermöglichen. Für die Verwendung des Paneels als Rückwand ist ein Befestigungssatz erforderlich. Das Paneel muss angebracht werden, bevor die Platte über den Unterschränken positioniert wird.

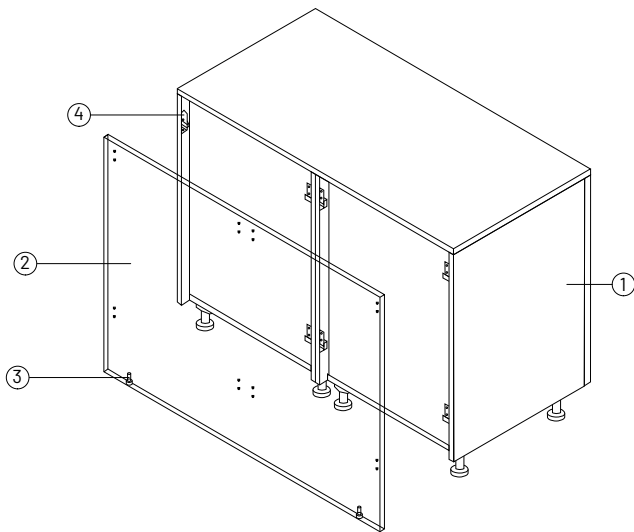

1. Base | Base | Base | Base | Basis

2. Pannello | Panel | Panneau | Panel | Panel

3. Piedino regolabile H. 0,5 cm | Adjustable foot H. 0.5 cm | Pied réglable H. 0,5 cm | Pie ajustable H. 0,5 cm | Panel

4. Kit di predisposizione per fissaggio pannello retrobase (1 kit per mobile) | Set-up kit for back panel fixing (1 kit per cabinet) | Kit de montage pour la fixation du panneau arrière (1 kit par armoire) | Kit de montage para la fijación del panel trasero (1 kit por armario) | Montagesatz für die Rückwandbefestigung (1 Satz pro Schrank)

Basi con maniglia
Base units with handle

Basi con gola
Base units with groove

Colonne
Tall units

Pensili
Wall units

Elementi speciali
Special elements

Maniglie gole zoccoli
Handles grooves plinth

Illuminazione
Lighting

Accessori
Accessories

Componenti e meccanismi
Components e mechanism

FINITURE PANNELLI

Panel Finishes
Finitions des panneaux
Acabados de los paneles
Finitions des panneaux

Pannelli spessore 1,6 / 1,8 / 2,2 cm con uno o entrambi i lati a vista. Individuare nella tabella la finitura desiderata per trovare tempi di consegna e fascia di prezzo.

Panels 1.6 / 1.8 / 2.2 cm thick with one or both sides exposed. Locate the desired finish in the table to find delivery time and price range.

Panneaux de 1,6 / 1,8 / 2,2 cm d'épaisseur avec un ou deux côtés exposés. Localisez la finition souhaitée dans le tableau pour connaître le délai de livraison et la fourchette de prix.

Paneles de 1,6 / 1,8 / 2,2 cm de grosor con una o ambas caras vistas. Localice el acabado deseado en la tabla para conocer el plazo de entrega y el rango de precios.

1,6 / 1,8 / 2,2 cm dicke Platten mit einer oder beiden Seiten offen. Suchen Sie die gewünschte Ausführung in der Tabelle, um die Lieferzeit und die Preisspanne zu ermitteln.

FINITURE FINISHES FINITIONS ACABADOS AUSFÜHRUNG	SETTIMANE WEEKS SEMAINES SEMANAS WOCHEN	FASCIA DI PREZZO PRICE RANGE CATÉGORIE DE PRIX CATEGORÍA DE PRECIO PREISKLASSE
<ul style="list-style-type: none"> MATERICO TEXTURED FINISH MU0 Bianco, MU1 Sabbia, MU2 Alpaca, MU3 Quarzo MR0 Perla, MR1 Argilla, MR2 Lava ML0 Noce California, ML1 Noce Alabama, ML2 Rovere Virginia, ML3 Rovere Termotrattato 	4	A
<ul style="list-style-type: none"> MATERICO TEXTURED FINISH MS0 Centauri, MS1 Eris, MS2 Bronzo, MS3 Metallo 	4	B
<ul style="list-style-type: none"> ULTRAMAT ULTRAMAT EM0 Bianco, EM1 Talpa, EM2 Lino, EM3 Mineral grey, EM4 Wine, EM5 Nero 	4	A
<ul style="list-style-type: none"> ULTRAGLOSS ULTRAGLOSS EL0 Bianco, EL1 Talpa, EL2 Lino 	4	A
<ul style="list-style-type: none"> LACCATO OPACO MATT LACQUER O10 Bianco, O00 Panna, O01 Crema, O02 Grigio Perla, O03 Grigio Seta, O04 Corda, O05 Moka, O06 Blu Cobalto, O07 Grigio Aston, O08 Grigio Antracite, O09 Nero 	5	A
<ul style="list-style-type: none"> LACCATO LUCIDO GLOSSY LACQUERED L10Bianco, L00 Panna, L01 Crema, L02 Grigio Perla, L03 Grigio Seta, L04 Corda, L05 Moka, L06 Blu Cobalto, L07 Grigio Aston, L08 Grigio Antracite, L09 Nero 	6	A
<ul style="list-style-type: none"> FENIX NTM® FENIX NTM® FM0 Bianco Kos, FM1 Beige Arizona, FM2 Castoro Ottawa, FM3 Grigio Londra, FM4 Rosso Jaipur, FM5 Verde Comodoro, FM6 Nero Ingo 	5	A
<ul style="list-style-type: none"> FENIX NTA® FENIX NTA® FA0 Hamilton, FA1 Dukat, FA2 Cortez 	5	B
<ul style="list-style-type: none"> LACCATO METALLO LACQUERED METAL L00 Ottone, L01 Acciaio, L02 Bronzo LS0 Oro, LS1 Ottone, LS2 Bronzo scuro, LS3 Titanio LA0 Ottone, LA1 Bronzo scuro, LA2 Silicio 	5	A
<ul style="list-style-type: none"> ESSENZA 1 WOOD 1 ER0 Rovere Visone, ER1 Rovere Castoro, ER2 Rovere Carbone, ER3 Rovere Cenere 	8	A
<ul style="list-style-type: none"> ESSENZA 2 WOOD 2 EE0 Noce Canaletto, EE1 Rovere Termotrattato 	8	B
<ul style="list-style-type: none"> METALMETAL T00 Nikel, T01 Titanio, T02Brown, T03Black 	?	?

PANNELLI

Panels
Panneaux
Paneles
Pannele

Pannello materico sp. 1,8 cm con due lati a vista e bordo ABS (finiture scocca)

1.8 cm thick textured panel with two exposed sides and ABS edge (shell finishes)
Panneau texturé de 1,8 cm d'épaisseur avec deux faces visibles et bord en ABS (finitions du corps)
Panel texturado de 1,8 cm de grosor con dos caras visibles y borde de ABS (acabados de carrocería)
1.8 cm dicke strukturierte Platte mit zwei sichtbaren Seiten und ABS-Kante (Karosserieausführung)

Quantità minima fatturabile 0,5 mq

Minimum billable quantity 0.5 sqm

Quantité minimale facturable 0,5 m2

Cantidad mínima facturable 0,5 m2

Abrechenbare Mindestmenge 0,5 Quadratmeter

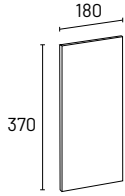

L MAX	H MAX	CODICE	PUNTI
180	370	KQNO1182LA	29

Foro per presa luce cad. PUNTI 32 COD. KMAGQ037

Hole for light socket | Trou pour la douille de lumière | Orificio para la toma de luz | Bohrung für Lichtsteckdose

Taglio fuori squadra cad. PUNTI 32 COD. KMAGQ006

Out-of-square cutting | Coupe hors d'équerre | Corte fuera de escuadra | Ungleichmäßiges Schneiden

Taglio interno o esterno cad. PUNTI 85 COD. KMAGQ005

Internal or external cut | Coupe interne ou externe | Corte interno o externo | Interner oder externer Schnitt

Kit di predisposizione per fissaggio pannello retrobase (1 kit per mobile) PUNTI 85 COD. KMAGPAN45

Set-up kit for back panel fixing (1 kit per cabinet) | Kit de montage pour la fixation du panneau arrière (1 kit par armoire) | Kit de montaje para la fijación del panel trasero (1 kit por armario) | Montagesatz für die Rückwandbefestigung (1 Satz pro Schrank)

Piedino regolabile H. 0,5 cm PUNTI 30 COD. KMAGPAN46

Adjustable foot H. 0.5 cm | Pied réglable H. 0,5 cm | Pie ajustable H. 0,5 cm | Verstellbarer Fuß H. 0,5 cm

Pannello materico sp. 1,8 / 2,2 cm con due lati a vista e bordo ABS

1.8 / 2.2 cm thick textured panel with two exposed sides and ABS edge
Panneau texturé de 1,8 / 2,2 cm d'épaisseur avec deux faces visibles et bordures en ABS
Panel texturado de 1,8 / 2,2 cm de grosor con dos caras visibles y borde de ABS
1.8 / 2.2 cm dicke strukturierte Platte mit zwei sichtbaren Seiten und ABS-Kante

Quantità minima fatturabile 0,5 mq

Minimum billable quantity 0.5 sqm

Quantité minimale facturable 0,5 m2

Cantidad mínima facturable 0,5 m2

Abrechenbare Mindestmenge 0,5 Quadratmeter

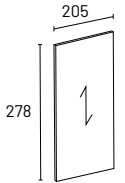

SP/TH	L MAX	H MAX	CODICE	PUNTI A	PUNTI B
1,8	205	278	KQME1182LA	79	-
1,8	205	278	KQME1182LB	-	83
2,2	205	278	KQME1222LA	97	-
2,2	205	278	KQME1222LB	-	102

Foro per presa luce cad. PUNTI 32 COD. KMAGQME37

Hole for light socket | Trou pour la douille de lumière | Orificio para la toma de luz | Bohrung für Lichtsteckdose

Taglio fuori squadra cad. PUNTI 32 COD. KMAGQME06

Out-of-square cutting | Coupe hors d'équerre | Corte fuera de escuadra | Ungleichmäßiges Schneiden

Taglio interno o esterno cad. PUNTI 85 COD. KMAGQME05

Internal or external cut | Coupe interne ou externe | Corte interno o externo | Interner oder externer Schnitt

Kit di predisposizione per fissaggio pannello retrobase (1 kit per mobile) PUNTI 85 COD. KMAGPAN45

Set-up kit for back panel fixing (1 kit per cabinet) | Kit de montage pour la fixation du panneau arrière (1 kit par armoire) | Kit de montaje para la fijación del panel trasero (1 kit por armario) | Montagesatz für die Rückwandbefestigung (1 Satz pro Schrank)

Piedino regolabile H. 0,5 cm PUNTI 30 COD. KMAGPAN46

Adjustable foot H. 0.5 cm | Pied réglable H. 0,5 cm | Pie ajustable H. 0,5 cm | Verstellbarer Fuß H. 0,5 cm

Basi con maniglia
Base units with handle

Basi con gola
Base units with groove

Colonne
Tall units

Pensili
Wall units

Elementi speciali
Special elements

Maniglie gole zoccoli
Handles grooves plinth

Illuminazione
Lighting

Accessori
Accessories

Componenti e meccanismi
Components e mechanism

PANNELLI

Panels
Panneaux
Paneles
Pannele

Pannello Ultramat sp. 1,8 / 2,2 cm con un lato a vista e bordo ABS

Ultramat panel 1.8 / 2.2 cm thick with one exposed side and ABS edge
Panneau Ultramat de 1,8 / 2,2 cm d'épaisseur avec une face exposée et un bord en ABS
Panel Ultramat de 1,8 / 2,2 cm de grosor con una cara vista y borde ABS
1,8 / 2,2 cm dicke Ultramat-Platte mit einer Sichtseite und ABS-Kante

Quantità minima fatturabile 0,5 mq

Minimum billable quantity 0.5 sqm

Quantité minimale facturable 0,5 m2

Cantidad mínima facturable 0,5 m2

Abrechenbare Mindestmenge 0,5 Quadratmeter

SP/TH	L MAX	H MAX	CODICE	PUNTI
1,8	120	278	KQUM1181LA	113
2,2	120	278	KQUM1221LA	119

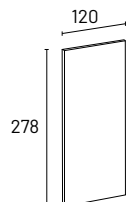

Foro per presa luce cad. PUNTI 32 COD. KMAGQUM37

Hole for light socket | Trou pour la douille de lumière | Orificio para la toma de luz | Bohrung für Lichtsteckdose

Taglio fuori squadra cad. PUNTI 32 COD. KMAGQUM06

Out-of-square cutting | Coupe hors d'équerre | Corte fuera de escuadra | Ungleichmäßiges Schneiden

Taglio interno o esterno cad. PUNTI 85 COD. KMAGQUM05

Internal or external cut | Coupe interne ou externe | Corte interno o externo | Interner oder externer Schnitt

Kit di predisposizione per fissaggio pannello retrobase (1 kit per mobile) PUNTI 85 COD. KMAGPAN45

Set-up kit for back panel fixing (1 kit per cabinet) | Kit de montage pour la fixation du panneau arrière (1 kit par armoire) | Kit de montaje para la fijación del panel trasero (1 kit por armario) | Montagesatz für die Rückwandbefestigung (1 Satz pro Schrank)

Piedino regolabile H. 0,5 cm PUNTI 30 COD. KMAGPAN46

Adjustable foot H. 0.5 cm | Pied réglable H. 0,5 cm | Pie ajustable H. 0,5 cm | Verstellbarer Fuß H. 0,5 cm

Pannello Ultragloss sp. 1,8 / 2,2 cm con un lato a vista e bordo ABS

Ultragloss panel 1.8 / 2.2 cm thick with one exposed side and ABS edge
Panneau ultra brillant de 1,8 / 2,2 cm d'épaisseur avec une face visible et un bord en ABS
Panel ultrabrillante de 1,8 / 2,2 cm de grosor con una cara visible y borde de ABS
1,8 / 2,2 cm starke Ultragloss-Platte mit einer Sichtseite und ABS-Kante

Quantità minima fatturabile 0,5 mq

Minimum billable quantity 0.5 sqm

Quantité minimale facturable 0,5 m2

Cantidad mínima facturable 0,5 m2

Abrechenbare Mindestmenge 0,5 Quadratmeter

SP/TH	L MAX	H MAX	CODICE	PUNTI
1,8	120	278	KQUG1181LA	279
2,2	120	278	KQUG1221LA	279

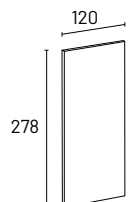

Foro per presa luce cad. PUNTI 32 COD. KMAGQUG37

Hole for light socket | Trou pour la douille de lumière | Orificio para la toma de luz | Bohrung für Lichtsteckdose

Taglio fuori squadra cad. PUNTI 32 COD. KMAGQUG06

Out-of-square cutting | Coupe hors d'équerre | Corte fuera de escuadra | Ungleichmäßiges Schneiden

Taglio interno o esterno cad. PUNTI 85 COD. KMAGQUG05

Internal or external cut | Coupe interne ou externe | Corte interno o externo | Interner oder externer Schnitt

Kit di predisposizione per fissaggio pannello retrobase (1 kit per mobile) PUNTI 85 COD. KMAGPAN45

Set-up kit for back panel fixing (1 kit per cabinet) | Kit de montage pour la fixation du panneau arrière (1 kit par armoire) | Kit de montaje para la fijación del panel trasero (1 kit por armario) | Montagesatz für die Rückwandbefestigung (1 Satz pro Schrank)

Piedino regolabile H. 0,5 cm PUNTI 30 COD. KMAGPAN46

Adjustable foot H. 0.5 cm | Pied réglable H. 0,5 cm | Pie ajustable H. 0,5 cm | Verstellbarer Fuß H. 0,5 cm

PANNELLI

Panels
Panneaux
Paneles
Paneele

Pannello Laccato Opaco sp.1,8 / 2,2 cm con due lati a vista

Matt lacquered panel 1.8 / 2.2 cm thick with two exposed sides
Panneau laqué mat de 1,8 / 2,2 cm d'épaisseur avec deux faces visibles
Panel lacado mate de 1,8 / 2,2 cm de grosor con dos caras visibles
1,8 / 2,2 cm starke, matt lackierte Platte mit zwei sichtbaren Seiten

Quantità minima fatturabile 0,5 mq

Minimum billable quantity 0.5 sqm
Quantité minimale facturable 0,5 m2
Cantidad mínima facturable 0,5 m2
Abrechenbare Mindestmenge 0,5 Quadratmeter

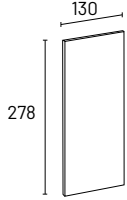

SP/TH	L MAX	H MAX	CODICE	PUNTI
1,8	130	278	KQLO1182LA	178
2,2	130	278	KQLO1222LA	178

Foro per presa luce cad. PUNTI 35 COD. KMAGQL037

Hole for light socket | Trou pour la douille de lumière | Orificio para la toma de luz | Bohrung für Lichtsteckdose

Taglio fuori squadra cad. PUNTI 42 COD. KMAGQL006

Out-of-square cutting | Coupe hors d'équerre | Corte fuera de escuadra | Ungleichmäßiges Schneiden

Taglio interno o esterno cad. PUNTI 85 COD. KMAGQL005

Internal or external cut | Coupe interne ou externe | Corte interno o externo | Interner oder externer Schnitt

Kit di predisposizione per fissaggio pannello retrobase (1 kit per mobile) PUNTI 85 COD. KMAGPAN45

Set-up kit for back panel fixing (1 kit per cabinet) | Kit de montage pour la fixation du panneau arrière (1 kit par armoire) | Kit de montaje para la fijación del panel trasero (1 kit por armario) | Montagesatz für die Rückwandbefestigung (1 Satz pro Schrank)

Piedino regolabile H. 0,5 cm PUNTI 30 COD. KMAGPAN46

Adjustable foot H. 0.5 cm | Pied réglable H. 0,5 cm | Pie ajustable H. 0,5 cm | Verstellbarer Fuß H. 0,5 cm

Pannello Laccato Lucido sp.1,8 / 2,2 cm con due lati a vista

Glossy Lacquered panel 1.8 / 2.2 cm thick with two exposed sides
Panneau laqué brillant de 1,8 / 2,2 cm d'épaisseur avec deux faces visibles
Panel lacado brillante de 1,8 / 2,2 cm de grosor con dos caras visibles
1,8 / 2,2 cm dicke, glänzend lackierte Platte mit zwei sichtbaren Seiten

Quantità minima fatturabile 0,5 mq

Minimum billable quantity 0.5 sqm
Quantité minimale facturable 0,5 m2
Cantidad mínima facturable 0,5 m2
Abrechenbare Mindestmenge 0,5 Quadratmeter

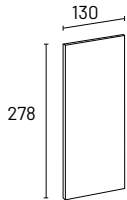

SP/TH	L MAX	H MAX	CODICE	PUNTI
1,8	130	278	KQLL1182LA	292
2,2	130	278	KQLL1222LA	292

Foro per presa luce cad. PUNTI 35 COD. KMAGQLL37

Hole for light socket | Trou pour la douille de lumière | Orificio para la toma de luz | Bohrung für Lichtsteckdose

Taglio fuori squadra cad. PUNTI 42 COD. KMAGQLL06

Out-of-square cutting | Coupe hors d'équerre | Corte fuera de escuadra | Ungleichmäßiges Schneiden

Taglio interno o esterno cad. PUNTI 85 COD. KMAGQLL05

Internal or external cut | Coupe interne ou externe | Corte interno o externo | Interner oder externer Schnitt

Kit di predisposizione per fissaggio pannello retrobase (1 kit per mobile) PUNTI 85 COD. KMAGPAN45

Set-up kit for back panel fixing (1 kit per cabinet) | Kit de montage pour la fixation du panneau arrière (1 kit par armoire) | Kit de montaje para la fijación del panel trasero (1 kit por armario) | Montagesatz für die Rückwandbefestigung (1 Satz pro Schrank)

Piedino regolabile H. 0,5 cm PUNTI 30 COD. KMAGPAN46

Adjustable foot H. 0.5 cm | Pied réglable H. 0,5 cm | Pie ajustable H. 0,5 cm | Verstellbarer Fuß H. 0,5 cm

Basi con maniglia
Base units with handle

Basi con gola
Base units with groove

Colonne
Tall units

Pensili
Wall units

Elementi speciali
Special elements

Maniglie gole zoccoli
Handles grooves plinth

Illuminazione
Lighting

Accessori
Accessories

Componenti e meccanismi
Components e mechanism

PANNELLI

Panels
Panneaux
Paneles
Paneele

Pannello laminato Fenix sp. 2,2 cm con due lati e bordo ABS

2.2 cm thick Fenix laminate panel with two sides and ABS edge
Panneau stratifié Fenix de 2,2 cm d'épaisseur avec deux faces et chant ABS
Panel laminado Fenix de 2,2 cm de grosor con dos caras y cantonera de ABS
2,2 cm dicke Fenix-Laminatplatte mit zwei Seiten und ABS-Kante

Quantità minima fatturabile 0,5 mq

Minimum billable quantity 0.5 sqm

Quantité minimale facturable 0,5 m2

Cantidad mínima facturable 0,5 m2

Abrechenbare Mindestmenge 0,5 Quadratmeter

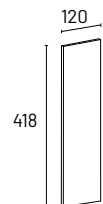

SP/TH	L MAX	H MAX	CODICE	PUNTI A	PUNTI B
2,2	120	418	KQFE1222LA	246	-
2,2	120	418	KQFE1222LB	-	624

Foro per presa luce cad. PUNTI 35 COD. KMAGQFE37

Hole for light socket | Trou pour la douille de lumière | Orificio para la toma de luz | Bohrung für Lichtsteckdose

Taglio fuori squadra cad. PUNTI 62 COD. KMAGQFE06

Out-of-square cutting | Coupe hors d'équerre | Corte fuera de escuadra | Ungleichmäßiges Schneiden

Taglio interno o esterno cad. PUNTI 100 COD. KMAGQFE05

Internal or external cut | Coupe interne ou externe | Corte interno o externo | Interner oder externer Schnitt

Kit di predisposizione per fissaggio pannello retrobase (1 kit per mobile) PUNTI 85 COD. KMAGPAN45

Set-up kit for back panel fixing (1 kit per cabinet) | Kit de montage pour la fixation du panneau arrière (1 kit par armoire) | Kit de montaje para la fijación del panel trasero (1 kit por armario) | Montagesatz für die Rückwandbefestigung (1 Satz pro Schrank)

Piedino regolabile H. 0,5 cm PUNTI 30 COD. KMAGPAN46

Adjustable foot H. 0.5 cm | Pied réglable H. 0,5 cm | Pie ajustable H. 0,5 cm | Verstellbarer Fuß H. 0,5 cm

Pannello laccato Metallo sp. 1,8 / 2,2 cm con due lati a vista

Metal lacquered panel 1.8 / 2.2 cm thick with two exposed sides
Panneau métallique laqué de 1,8 / 2,2 cm d'épaisseur avec deux faces visibles
Panel metálico lacado de 1,8 / 2,2 cm de grosor con dos caras visibles
Lackierte Metallplatte 1,8 / 2,2 cm dick mit zwei sichtbaren Seiten

Quantità minima fatturabile 0,5 mq

Minimum billable quantity 0.5 sqm

Quantité minimale facturable 0,5 m2

Cantidad mínima facturable 0,5 m2

Abrechenbare Mindestmenge 0,5 Quadratmeter

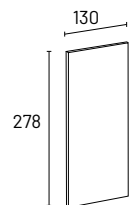

SP/TH	L MAX	H MAX	CODICE	PUNTI
1,8	130	278	KQLM1182LA	537
2,2	130	278	KQLM1222LA	549

Foro per presa luce cad. PUNTI 35 COD. KMAGQLM37

Hole for light socket | Trou pour la douille de lumière | Orificio para la toma de luz | Bohrung für Lichtsteckdose

Taglio fuori squadra cad. PUNTI 45 COD. KMAGQLM06

Out-of-square cutting | Coupe hors d'équerre | Corte fuera de escuadra | Ungleichmäßiges Schneiden

Taglio interno o esterno cad. PUNTI 88 COD. KMAGQLM05

Internal or external cut | Coupe interne ou externe | Corte interno o externo | Interner oder externer Schnitt

Kit di predisposizione per fissaggio pannello retrobase (1 kit per mobile) PUNTI 85 COD. KMAGPAN45

Set-up kit for back panel fixing (1 kit per cabinet) | Kit de montage pour la fixation du panneau arrière (1 kit par armoire) | Kit de montaje para la fijación del panel trasero (1 kit por armario) | Montagesatz für die Rückwandbefestigung (1 Satz pro Schrank)

Piedino regolabile H. 0,5 cm PUNTI 30 COD. KMAGPAN46

Adjustable foot H. 0.5 cm | Pied réglable H. 0,5 cm | Pie ajustable H. 0,5 cm | Verstellbarer Fuß H. 0,5 cm

PANNELLI

Panels
Panneaux
Paneles
Paneele

Pannello con Essenza sp. 1,8 cm con venatura orizzontale, un lato a vista e lato interno melaminico tinta scocca

Panel with Essence 1.8 cm thick with horizontal grain, one side exposed and inner side melamine body colour
Panneau Essenza de 1,8 cm d'épaisseur à grain horizontal, une face visible et une face intérieure mélaminée dans la couleur de la carrosserie
Panel Essenza de 1,8 cm de grosor con veteado horizontal, una cara vista y cara interior recubierta de melamina en color carrocería
1,8 cm starke Essenza-Platte mit horizontaler Maserung, einer Sichtseite und melaminbeschichteter Innenseite in Wagenfarbe

Quantità minima fatturabile 0,5 mq

Minimum billable quantity 0.5 sqm
Quantité minimale facturable 0,5 m2
Cantidad mínima facturable 0,5 m2
Abrechenbare Mindestmenge 0,5 Quadratmeter

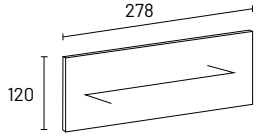

SP/TH	L MAX	H MAX	CODICE	PUNTI A	PUNTI B
1,8	278	120	KQES1181LA	485	-
1,8	278	120	KQES1181LB	-	506

Foro per presa luce cad. PUNTI 50 COD. K MAG0ES37

Hole for light socket | Trou pour la douille de lumière | Orificio para la toma de luz | Bohrung für Lichtsteckdose

Taglio fuori squadra cad. PUNTI 50 COD. K MAG0ES06

Out-of-square cutting | Coupe hors d'équerre | Corte fuera de escuadra | Ungleichmäßiges Schneiden

Taglio interno o esterno cad. PUNTI 139 COD. K MAG0ES05

Internal or external cut | Coupe interne ou externe | Corte interno o externo | Interner oder externer Schnitt

Pannello con Essenza sp. 1,8 cm con venatura verticale, un lato a vista e lato interno melaminico tinta scocca

Panel with Essence 1.8 cm thick with vertical grain, one side exposed and inner side melamine body colour
Panneau Essenza de 1,8 cm d'épaisseur à grain vertical, une face visible et une face intérieure mélaminée dans la couleur de la carrosserie
Panel Essenza de 1,8 cm de grosor con veta vertical, una cara vista y cara interior recubierta de melamina en el color de la carrocería
Paneel mit 1,8 cm starkem Essenza mit vertikaler Maserung, eine Seite sichtbar und Innenseite melaminharzbeschichtet

Quantità minima fatturabile 0,5 mq

Minimum billable quantity 0.5 sqm
Quantité minimale facturable 0,5 m2
Cantidad mínima facturable 0,5 m2
Abrechenbare Mindestmenge 0,5 Quadratmeter

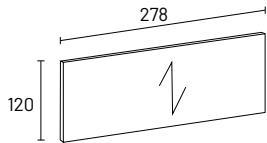

SP/TH	L MAX	H MAX	CODICE	PUNTI A	PUNTI B
1,8	278	120	KQES2181LA	485	-
1,8	278	120	KQES2181LB	-	506

Foro per presa luce cad. PUNTI 50 COD. K MAG0ES37

Hole for light socket | Trou pour la douille de lumière | Orificio para la toma de luz | Bohrung für Lichtsteckdose

Taglio fuori squadra cad. PUNTI 50 COD. K MAG0ES06

Out-of-square cutting | Coupe hors d'équerre | Corte fuera de escuadra | Ungleichmäßiges Schneiden

Taglio interno o esterno cad. PUNTI 139 COD. K MAG0ES05

Internal or external cut | Coupe interne ou externe | Corte interno o externo | Interner oder externer Schnitt

Kit di predisposizione per fissaggio pannello retrobase (1 kit per mobile) PUNTI 85 COD. K MAGPAN45

Set-up kit for back panel fixing (1 kit per cabinet) | Kit de montage pour la fixation du panneau arrière (1 kit par armoire) | Kit de montaje para la fijación del panel trasero (1 kit por armario) | Montagesatz für die Rückwandbefestigung (1 Satz pro Schrank)

Piedino regolabile H. 0,5 cm PUNTI 30 COD. K MAGPAN46

Adjustable foot H. 0.5 cm | Pied réglable H. 0,5 cm | Pie ajustable H. 0,5 cm | Verstellbarer Fuß H. 0,5 cm

Basi con maniglia
Base units with handle

Basi con gola
Base units with groove

Colonne
Tall units

Pensili
Wall units

Elementi speciali
Special elements

Maniglie gole zoccoli
Handles grooves plinth

Illuminazione
Lighting

Accessori
Accessories

Componenti e meccanismi
Components e mechanism

PANNELLI

Panels
Panneaux
Paneles
Paneele

Pannello con Essenza sp. 1,6 / 2,2 cm con venatura orizzontale e due lati a vista

Panel with Essence thickness 1,6 / 2,2 cm with horizontal grain and two exposed sides
Panneau avec Essenza 1,6 / 2,2 cm d'épaisseur avec grain horizontal et deux faces visibles
Panel con Essenza de 1,6 / 2,2 cm de grosor con veta horizontal y dos caras vistas
Paneel mit Essenza 1,6 / 2,2 cm dick mit horizontaler Maserung und zwei sichtbaren Seiten

Quantità minima fatturabile 0,5 mq

Minimum billable quantity 0.5 sqm

Quantité minimale facturable 0,5 m2

Cantidad mínima facturable 0,5 m2

Abrechenbare Mindestmenge 0,5 Quadratmeter

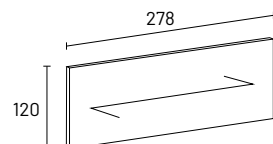

SP/TH	L MAX	H MAX	CODICE	PUNTI A	PUNTI B
1,6	278	120	KQES3162LA	561	-
1,6	278	120	KQES3162LB	-	591
2,2	278	120	KQES3222LA	561	-
2,2	278	120	KQES3222LB	-	591

Foro per presa luce cad. PUNTI 50 COD. K MAGQES37

Hole for light socket | Trou pour la douille de lumière | Orificio para la toma de luz | Bohrung für Lichtsteckdose

Taglio fuori squadra cad. PUNTI 50 COD. K MAGQES06

Out-of-square cutting | Coupe hors d'équerre | Corte fuera de escuadra | Ungleichmäßiges Schneiden

Taglio interno o esterno cad. PUNTI 139 COD. K MAGQES05

Internal or external cut | Coupe interne ou externe | Corte interno o externo | Interner oder externer Schnitt

Kit di predisposizione per fissaggio pannello retrobase (1 kit per mobile) PUNTI 85 COD. K MAGPAN45

Set-up kit for back panel fixing (1 kit per cabinet) | Kit de montage pour la fixation du panneau arrière (1 kit par armoire) | Kit de montaje para la fijación del panel trasero (1 kit por armario) | Montagesatz für die Rückwandbefestigung (1 Satz pro Schrank)

Piedino regolabile H. 0,5 cm PUNTI 30 COD. K MAGPAN46

Adjustable foot H. 0,5 cm | Pied réglable H. 0,5 cm | Pie ajustable H. 0,5 cm | Verstellbarer Fuß H. 0,5 cm

Pannello con Essenza sp. 1,6 / 2,2 cm con venatura verticale e due lati a vista

Panel with Essence thickness 1,6 / 2,2 cm with vertical grain and two exposed sides
Panneau avec Essenza 1,6 / 2,2 cm d'épaisseur avec grain vertical et deux faces visibles
Panel con Essenza de 1,6 / 2,2 cm de grosor con veta vertical y dos caras vistas
Paneel mit Essenza 1,6 / 2,2 cm dick mit vertikaler Maserung und zwei sichtbaren Seiten

Quantità minima fatturabile 0,5 mq

Minimum billable quantity 0.5 sqm

Quantité minimale facturable 0,5 m2

Cantidad mínima facturable 0,5 m2

Abrechenbare Mindestmenge 0,5 Quadratmeter

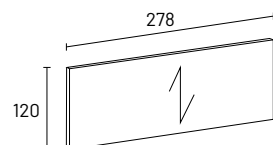

SP/TH	L MAX	H MAX	CODICE	PUNTI A	PUNTI B
1,6	278	120	KQES4162LA	561	-
1,6	278	120	KQES4162LB	-	591
2,2	278	120	KQES4222LA	561	-
2,2	278	120	KQES4222LB	-	591

Foro per presa luce cad. PUNTI 50 COD. K MAGQES37

Hole for light socket | Trou pour la douille de lumière | Orificio para la toma de luz | Bohrung für Lichtsteckdose

Taglio fuori squadra cad. PUNTI 50 COD. K MAGQES06

Out-of-square cutting | Coupe hors d'équerre | Corte fuera de escuadra | Ungleichmäßiges Schneiden

Taglio interno o esterno cad. PUNTI 139 COD. K MAGQES05

Internal or external cut | Coupe interne ou externe | Corte interno o externo | Interner oder externer Schnitt

Kit di predisposizione per fissaggio pannello retrobase (1 kit per mobile) PUNTI 85 COD. K MAGPAN45

Set-up kit for back panel fixing (1 kit per cabinet) | Kit de montage pour la fixation du panneau arrière (1 kit par armoire) | Kit de montaje para la fijación del panel trasero (1 kit por armario) | Montagesatz für die Rückwandbefestigung (1 Satz pro Schrank)

Piedino regolabile H. 0,5 cm PUNTI 30 COD. K MAGPAN46

Adjustable foot H. 0,5 cm | Pied réglable H. 0,5 cm | Pie ajustable H. 0,5 cm | Verstellbarer Fuß H. 0,5 cm

PANNELLI

Panels
Panneaux
Paneles
Paneele

Pannello Metal sp. 1,6 cm con un lato a vista e lato interno in tinta

Metal panel 1.6 cm thick with one side exposed and inner side matching
Panneau métallique de 1,6 cm d'épaisseur avec une face visible et une face intérieure assortie
Panel metálico de 1,6 cm de grosor con una cara visible y otra interior a juego
1,6 cm starke Metallplatte mit einer Sichtseite und einer passenden Innenseite

Quantità minima fatturabile 0,5 mq

Minimum billable quantity 0.5 sqm

Quantité minimale facturable 0,5 m2

Cantidad mínima facturable 0,5 m2

Abrechenbare Mindestmenge 0,5 Quadratmeter

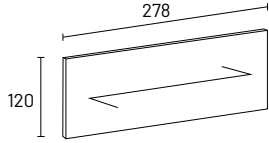

SP/TH	L MAX	H MAX	CODICE	PUNTI
1,6	278	120	KQMT1161LA	930

Foro per presa luce cad. PUNTI 105 COD. K MAGQMT37

Hole for light socket | Trou pour la douille de lumière | Orificio para la toma de luz | Bohrung für Lichtsteckdose

Tagli fuori squadra cad. PUNTI 150 COD. K MAGQMT06

Off-team cuts | Coupures hors équipe | Recortes fuera del equipo | Kürzungen außerhalb des Teams

Taglio interno o esterno cad. PUNTI 150 COD. K MAGQMT05

Internal or external cut | Coupe interne ou externe | Corte interno o externo | Interner oder externer Schnitt

Kit di predisposizione per fissaggio pannello retrobase (1 kit per mobile) PUNTI 85 COD. K MAGPAN45

Set-up kit for back panel fixing (1 kit per cabinet) | Kit de montage pour la fixation du panneau arrière (1 kit par armoire) | Kit de montaje para la fijación del panel trasero (1 kit por armario) | Montagesatz für die Rückwandbefestigung (1 Satz pro Schrank)

Piedino regolabile H. 0,5 cm PUNTI 30 COD. K MAGPAN46

Adjustable foot H. 0.5 cm | Pied réglable H. 0,5 cm | Pie ajustable H. 0,5 cm | Verstellbarer Fuß H. 0,5 cm

Pannello Metal sp. 1,6 cm con due lati a vista

Metal panel 1.6 cm thick with two exposed sides
Panneau métallique de 1,6 cm d'épaisseur avec deux faces visibles
Panel metálico de 1,6 cm de grosor con dos caras visibles
1,6 cm starke Metallplatte mit zwei sichtbaren Seiten

Quantità minima fatturabile 0,5 mq

Minimum billable quantity 0.5 sqm

Quantité minimale facturable 0,5 m2

Cantidad mínima facturable 0,5 m2

Abrechenbare Mindestmenge 0,5 Quadratmeter

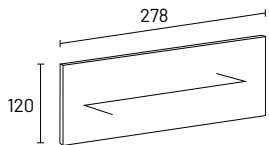

SP/TH	L MAX	H MAX	CODICE	PUNTI
1,6	278	120	KQMT2162LA	975

Foro per presa luce cad. PUNTI 105 COD. K MAGQMT37

Hole for light socket | Trou pour la douille de lumière | Orificio para la toma de luz | Bohrung für Lichtsteckdose

Tagli fuori squadra cad. PUNTI 150 COD. K MAGQMT06

Out-of-square cutting | Coupe hors d'équerre | Corte fuera de escuadra | Ungleichmäßiges Schneiden

Taglio interno o esterno cad. PUNTI 150 COD. K MAGQMT05

Internal or external cut | Coupe interne ou externe | Corte interno o externo | Interner oder externer Schnitt

Kit di predisposizione per fissaggio pannello retrobase (1 kit per mobile) PUNTI 85 COD. K MAGPAN45

Set-up kit for back panel fixing (1 kit per cabinet) | Kit de montage pour la fixation du panneau arrière (1 kit par armoire) | Kit de montaje para la fijación del panel trasero (1 kit por armario) | Montagesatz für die Rückwandbefestigung (1 Satz pro Schrank)

Piedino regolabile H. 0,5 cm PUNTI 30 COD. K MAGPAN46

Adjustable foot H. 0.5 cm | Pied réglable H. 0,5 cm | Pie ajustable H. 0,5 cm | Verstellbarer Fuß H. 0,5 cm

Basi con maniglia
Base units with handle

Basi con gola
Base units with groove

Colonne
Tall units

Pensili
Wall units

Elementi speciali
Special elements

Maniglie gole zoccoli
Handles grooves plinth

Illuminazione
Lighting

Accessori
Accessories

Componenti e meccanismi
Components e mechanism

MENSOLE

Shelves
Étagères
Estanterías
Regale

Sono disponibili mensole e mensole con frontalino in Dekton o MDI. Entrambe le versioni possono essere dotate di illuminazione LED (ulteriori specifiche sul listino Sistema Cucine) e possono essere fissate a parete oppure su schienale. La lunghezza massima della mensola è 240 cm e minima 24 cm.

Dekton or MDI fronted shelves and shelves are available. Both versions can be equipped with LED lighting (more specifications on the Sistema Cucine price list) and can be wall-mounted or back-mounted. Maximum shelf length is 240 cm and minimum 24 cm.

Des étagères et des tablettes avec façades Dekton ou MDI sont disponibles. Les deux versions peuvent être équipées d'un éclairage LED (pour plus de détails, voir le tarif Sistema Cucine) et peuvent être fixées au mur ou à la paroi arrière. La longueur maximale de l'étagère est de 240 cm et la longueur minimale de 24 cm.

Están disponibles estantes y baldas con frentes Dekton o MDI. Ambas versiones pueden equiparse con iluminación LED (más especificaciones en la lista de precios de Sistema Cucine) y pueden fijarse a la pared o al panel trasero. La longitud máxima del estante es de 240 cm y la mínima de 24 cm.

Es sind Regale und Ablagen mit Dekton- oder MDI-Fronten erhältlich. Beide Versionen können mit LED-Beleuchtung ausgestattet werden (weitere Angaben in der Preisliste von Sistema Cucine) und können an der Wand oder an der Rückwand befestigt werden. Die maximale Länge des Regals beträgt 240 cm und die minimale Länge 24 cm.

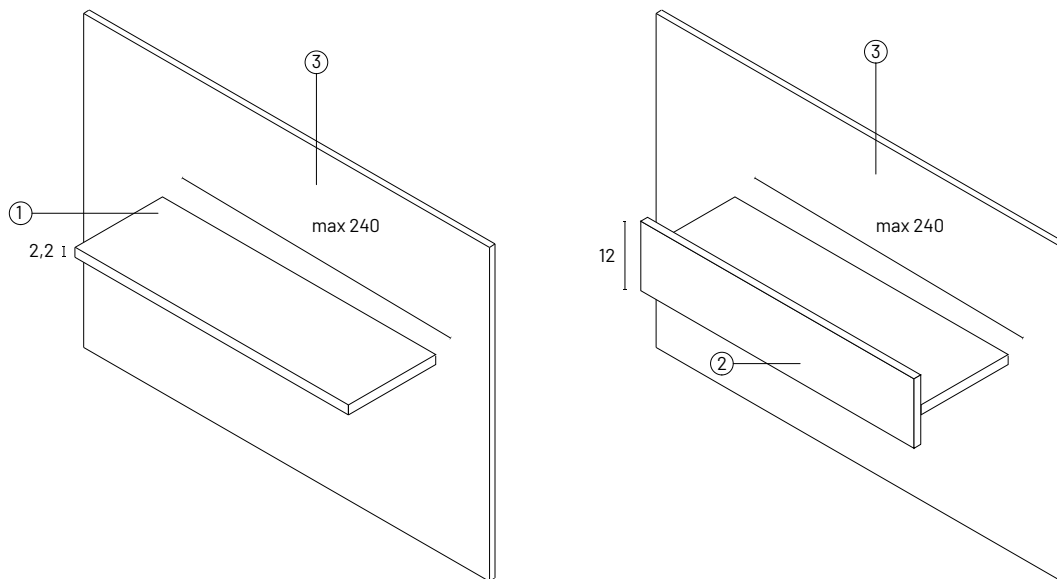

1. Mensola | Shelf | Étagère | Estante | Regal
2. Mensola con frontalino | Shelf with faceplate | Étagère avec plastron | Estante con placa frontal | Regal mit Frontplatte
3. Schienale | Backpanel | Dossier | Respaldo | Regal mit Frontplatte

FINITURE MENSOLE

Shelf finishes
Finitions des étagères
Acabados de estanterías
Ausführungen der Regale

Mensole sp. 2,2 cm per fissaggio a parete o su schienale. Individuare nella tabella la finitura desiderata per trovare tempi di consegna e fascia di prezzo.

Shelves 2.2 cm thick for wall or back-mounting. Locate the desired finish in the table to find delivery time and price range.

Tablettes de 2,2 cm d'épaisseur à fixer au mur ou à l'arrière. Localisez la finition souhaitée dans le tableau pour connaître le délai de livraison et la fourchette de prix.

Estantes de 2,2 cm de grosor para fijación mural o trasera. Localice el acabado deseado en la tabla para conocer el plazo de entrega y el rango de precios.

2,2 cm dicke Einlegeböden zur Wand- oder Rückwandbefestigung. Suchen Sie die gewünschte Ausführung in der Tabelle, um Lieferzeit und Preisspanne zu erfahren.

FINITURE FINISHES FINITIONS ACABADOS AUSFÜHRUNG	SETTIMANE WEEKS SEMAINES SEMANAS WOCHE	FASCIA DI PREZZO PRICE RANGE CATÉGORIE DE PRIX CATAGORÍA DE PRECIO PREISKLASSE
<ul style="list-style-type: none"> MATERICO TEXTURED FINISH MU0 Bianco, MU1 Sabbia, MU2 Alpaca, MU3 Quarzo MS0 Centauri, MS1 Eris, MS2 Bronzo, MS3 Metallo MR0 Perla, MR1 Argilla, MR2 Lava ML0 Noce California, ML1 Noce Alabama, ML2 Rovere Virginia, ML3 Rovere Termotrattato 	4	0
<ul style="list-style-type: none"> ULTRAMAT ULTRAMAT EM0 Bianco, EM1 Talpa, EM2 Lino, EM3 Mineral grey, EM4 Wine, EM5 Nero 	4	2
<ul style="list-style-type: none"> ULTRAGLOSS ULTRAGLOSS EL0 Bianco, EL1 Talpa, EL2 Lino 	4	2
<ul style="list-style-type: none"> LACCATO OPACO MATT LACQUER O10 Bianco, O00 Panna, O01 Crema, O02 Grigio Perla, O03 Grigio Seta, O04 Corda, O05 Moka, O06 Blu Cobalto, O07 Grigio Aston, O08 Grigio Antracite, O09 Nero 	5	3
<ul style="list-style-type: none"> LACCATO LUCIDO GLOSSY LACQUERED L10 Bianco, L00 Panna, L01 Crema, L02 Grigio Perla, L03 Grigio Seta, L04 Corda, L05 Moka, L06 Blu Cobalto, L07 Grigio Aston, L08 Grigio Antracite, L09 Nero 	6	5
<ul style="list-style-type: none"> FENIX NTM® FENIX NTM® FM0 Bianco Kos, FM1 Beige Arizona, FM2 Castoro Ottawa, FM3 Grigio Londra, FM4 Rosso Jaipur, FM5 Verde Comodoro, FM6 Nero Ingo 	5	4
<ul style="list-style-type: none"> FENIX NTA® FENIX NTA® FA0 Hamilton, FA1 Dukat, FA2 Cortez 	5	8
<ul style="list-style-type: none"> LACCATO METALLO LACQUERED METAL L00 Ottone, L01 Acciaio, L02 Bronzo LS0 Oro, LS1 Ottone, LS2 Bronzo scuro, LS3 Titanio LA0 Ottone, LA1 Bronzo scuro, LA2 Silicio 	8	9
<ul style="list-style-type: none"> ESSENZA 1 WOOD 1 ER0 Rovere Visone, ER1 Rovere Castoro, ER2 Rovere Carbone, ER3 Rovere Cenere 	8	7
<ul style="list-style-type: none"> ESSENZA 2 WOOD 2 EE0 Noce Canaletto, EE1 Rovere Termotrattato 	8	9

Basi con maniglia
Base units with handle

Basi con gola
Base units with groove

Colonne
Tall units

Pensili
Wall units

Elementi speciali
Special elements

Maniglie gole zoccoli
Handles grooves plinth

Illuminazione
Lighting

Accessori
Accessories

Componenti e meccanismi
Components e mechanism

MENSOLE

Shelves
Étagères
Estanterías
Regale

Mensole sp. 2,2 cm (prezzi al metro lineare)

Shelves 2.2 cm thick (prices per linear meter)
Tablettes de 2,2 cm d'épaisseur (prix au mètre courant)
Baldas de 2,2 cm de grosor (precios por metro lineal)
Fachböden 2,2 cm dick (Preise pro laufendem Meter)

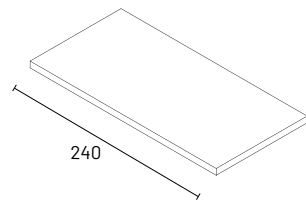

P/D	L MAX	CODICE	0	1	2	3	4	5	6	7	8	9	10
22	240	KMEN122022	26	-	61	64	68	72	-	121	130	0	-
37	240	KMEN122037	31	-	103	105	108	110	-	203	210	255	-
60	240	KMEN122060	50	-	167	172	175	181	-	329	346	414	-
120	240	KMEN422120	97	-	279	280	290	295	-	549	561	690	-

Taglio fuori squadra cad. PUNTI 62 COD. KMAGMEN06

Out-of-square cutting | Coupe hors d'équerre | Corte fuera de escuadra | Ungleichmäßiges Schneiden

Taglio interno o esterno cad. PUNTI 100 COD. KMAGMEN05

Internal or external cut | Coupe interne ou externe | Corte interno o externo | Interner oder externer Schnitt

Sagomatura camino cappa cad. PUNTI 95 COD. KMAGMEN53

Chimney hood moulding | Moulure de la hotte de cheminée | Moldura de campana de chimenea | Kaminhaubenformteil

Testa smussata o tonda cad. PUNTI 132 COD. KMAGMEN08

Chamfered or round edge | Bords chanfreinés ou arrondis | Borde biselado o redondeado | Abgeschrägte oder runde Seite

Lavorazione per fissaggio a parete (2 supporti) fino L. 75 cm cad. PUNTI 15 COD. KMAGMEN50

Machining for wall mounting (2 supports) up to L. 75 cm | Usinage pour montage mural (2 supports) jusqu'à L. 75 cm | Mecanizado para montaje en pared (2 soportes) hasta L. 75 cm | Bearbeitung für Wandmontage (2 Stützen) bis zu L. 75 cm

Lavorazione per fissaggio a parete (3 supporti) da L. 75 cm a L. 120 cm cad. PUNTI 23 COD. KMAGMEN51

Machining for wall mounting (3 supports) from L. 75 cm to L. 120 cm | Usinage pour fixation murale (3 supports) de L. 75 cm à L. 120 cm | Mecanizado para montaje en pared (3 soportes) de A. 75 cm a A. 120 cm | Bearbeitung für Wandmontage (3 Stützen) von B. 75 cm bis B. 120 cm

Lavorazione per fissaggio a parete (4 supporti) da L. 121 cm a L. 240 cm cad. PUNTI 30 COD. KMAGMEN52

Machining for wall mounting (4 supports) from L. 121 cm to L. 240 cm | Usinage pour montage mural (4 supports) de L. 121 cm à L. 240 cm | Mecanizado para montaje en pared (4 soportes) de A. 121 cm a A. 240 cm | Bearbeitung für Wandmontage (4 Stützen) von B. 121 cm bis B. 240 cm

Supporto laterale (1 lato) P. 37 cm cad. PUNTI 10 COD. KMAGMEN63

Side support (1 side) D. 37 cm | Support latéral (1 côté) D. 37 cm | Soporte lateral (1 lado) D. 37 cm | Seitenstütze (1 Seite) D. 37 cm

Mensole sp. 2,2 cm con frontalino in Dekton o Mdi (prezzi al metro lineare)

Shelves 2.2 cm thick with Dekton or Mdi front panel (prices per linear meter)
Tablettes de 2,2 cm d'épaisseur avec façade Dekton ou Mdi (prix au mètre courant)
Estantes de 2,2 cm de grosor con panel frontal Dekton o Mdi (precios por metro lineal)
Fachböden 2,2 cm dick mit Dekton- oder Mdi-Frontplatte (Preise pro laufendem Meter)

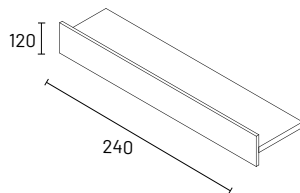

	P/D	L MAX	CODICE	0	1	2	3	4	5	6	7	8	9	10
at mtl.	21,2	240	KMEN2120021	224	-	259	260	262	266	-	319	324	346	-
at mtl.	21,2	240	KMEN3120021	224	-	259	260	262	266	-	319	324	346	-

Lavorazione per fissaggio a parete (2 supporti) fino L. 75 cm cad. PUNTI 15 COD. KMAGMEN50

Machining for wall mounting (2 supports) up to L. 75 cm | Usinage pour montage mural (2 supports) jusqu'à L. 75 cm | Mecanizado para montaje en pared (2 soportes) hasta L. 75 cm | Bearbeitung für Wandmontage (2 Stützen) bis zu L. 75 cm

Lavorazione per fissaggio a parete (3 supporti) da L. 75 cm a L. 120 cm cad. PUNTI 23 COD. KMAGMEN51

Machining for wall mounting (3 supports) from L. 75 cm to L. 120 cm | Usinage pour fixation murale (3 supports) de L. 75 cm à L. 120 cm | Mecanizado para montaje en pared (3 soportes) de A. 75 cm a A. 120 cm | Bearbeitung für Wandmontage (3 Stützen) von B. 75 cm bis B. 120 cm

Lavorazione per fissaggio a parete (4 supporti) da L. 121 cm a L. 240 cm cad. PUNTI 30 COD. KMAGMEN52

Machining for wall mounting (4 supports) from L. 121 cm to L. 240 cm | Usinage pour montage mural (4 supports) de L. 121 cm à L. 240 cm | Mecanizado para montaje en pared (4 soportes) de A. 121 cm a A. 240 cm | Bearbeitung für Wandmontage (4 Stützen) von B. 121 cm bis B. 240 cm

MENSOLE

Shelves
Étagères
Estanterías
Regale

Staffa L per fissaggio mensole su schienale

L bracket for fixing shelves on backpanel
Support L pour la fixation des supports sur le dossier
Soporte L para la fijación de los soportes en el respaldo
Halterung L zur Befestigung der Halterungen an der Rückenlehne

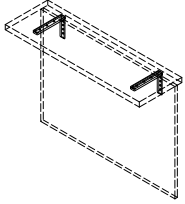

CODICE | PUNTI
09K0000047 | 63

Basi con maniglia
Base units with handle

Basi con gola
Base units with groove

Colonne
Tall units

Pensili
Wall units

Elementi speciali
Special elements

Schienale sp. 2,2 cm per mensola (prezzi al metro quadrato)

2.2 cm thick back for shelves (prices per square meter)
Panneau arrière de 2,2 cm d'épaisseur pour les étagères (prix au mètre carré)
Panel trasero de 2,2 cm de grosor para estantes (precios por metro cuadrado)
2,2 cm dicke Rückwand für Regale (Preise pro Quadratmeter)

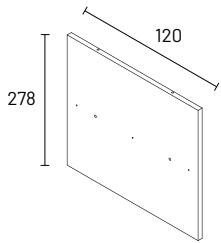

L MAX	H MAX	CODICE	0	1	2	3	4	5	6	7	8	9	10
120	278	KSCME22	97	-	279	280	290	295	-	549	561	690	-

Maniglie gole zoccoli
Handles grooves plinth

Illuminazione
Lighting

Accessori
Accessories

Lavorazione per fissaggio mensola (2 supporti) fino L. 75 cm cad. PUNTI 15 COD. KMGASME57

Machining for fixing shelf (2 supports) up to L. 75 cm | Usinage pour la fixation de l'étrier (2 supports) jusqu'à L. 75 cm | Mecanizado para fijación de soportes (2 soportes) hasta L. 75 cm | Bearbeitung für Bügelbefestigung (2 Stützen) bis zu L. 75 cm

Lavorazione per fissaggio mensola (3 supporti) da L. 75 cm a L. 120 cm cad. PUNTI 23 COD. KMGASME58

Machining for fixing shelf (3 supports) from L. 75 cm to L. 120 cm | Usinage pour la fixation de l'étrier (3 supports) de L. 75 cm à L. 120 cm | Mecanizado para fijación de soportes (3 soportes) de An. 75 cm a An. 120 cm | Bearbeitung für Bügelbefestigung (3 Stützen) von B. 75 cm bis B. 120 cm

Componenti e meccanismi
Components e mechanism

MENSOLE

Shelves
Étagères
Estanterías
Regale

Mensole sp. 2,2 cm per schienale (prezzi al metro lineare)

Shelves 2.2 cm thick for backs (prices per linear meter)
Tablettes de 2,2 cm d'épaisseur pour les dossiers (prix au mètre courant)
Baldas de 2,2 cm de grosor para respaldos (precios por metro lineal)
Einlegeböden 2,2 cm dick für Rückwände (Preise pro laufendem Meter)

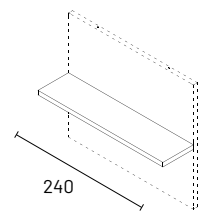

P/D	L MAX	CODICE	0	1	2	3	4	5	6	7	8	9	10
22	240	KMEN522022	26	-	61	64	68	72	-	121	130	152	-
37	240	KMEN522037	31	-	103	105	108	110	-	203	210	255	-

Lavorazione per fissaggio su schienale (2 supporti) fino L. 75 cm cad. PUNTI15 COD. KMAGMEN54

Machining for fixing on backpanel (2 supports) up to W. 75 cm | Usinage pour fixation sur le dossier (2 supports) jusqu'à L. 75 cm | Mecanizado para fijación en respaldo (2 soportes) hasta L. 75 cm | Bearbeitung zur Befestigung an der Rückenlehne (2 Stützen) bis zu L. 75 cm

Lavorazione per fissaggio su schienale (3 supporti) da L. 75 cm a L. 120 cm cad. PUNTI23 COD. KMAGMEN55

Machining for fixing on backpanel (3 supports) from W. 75 cm to W. 120 cm | Usinage pour fixation sur le dossier (3 supports) de L. 75 cm à L. 120 cm | Mecanizado para fijación en respaldo (3 soportes) de L. 75 cm a L. 120 cm | Bearbeitungen zur Befestigung an der Rückenlehne (3 Stützen) von L. 75 cm bis L. 120 cm

Lavorazione per fissaggio su schienale (4 supporti) da L. 121 cm a L. 240 cm cad. PUNTI30 COD. KMAGMEN56

Machining for fixing on backpanel (4 supports) from W. 121 cm to W. 240 cm | Usinage pour fixation sur le dossier (4 supports) de L. 121 cm à L. 240 cm | Mecanizado para fijación en respaldo (4 soportes) de A. 121 cm a A. 240 cm | Bearbeitungen zur Befestigung an der Rückenlehne (4 Stützen) von B. 121 cm bis B. 240 cm

Supporto laterale (1 lato) P. 37 cm cad. PUNTI10 COD. KMAGMEN63

Side support (1 side) D. 37 cm | Support latéral (1 côté) D. 37 cm | Soporte lateral (1 lado) D. 37 cm | Seitenstütze (1 Seite) D. 37 cm

Mensola sp. 2,2 cm con frontalino in Dekton o MDI Inalco per schienale (prezzi a metro lineare)

2,2 cm thick shelf with Dekton or MDI Inalco front panel for back panel (prices per linear meter)
Tablette de 2,2 cm d'épaisseur avec panneau arrière Dekton ou MDI Inalco (prix par mètre courant)
Balda de 2,2 cm de grosor con trasera Dekton o MDI Inalco (precios por metro lineal)
Regalboden 2,2 cm dick mit Dekton- oder MDI Inalco-Rückwand (Preise pro laufendem Meter)

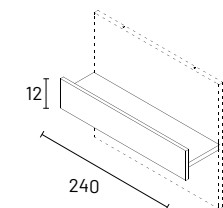

	P/D	L MAX	CODICE	0	1	2	3	4	5	6	7	8	9	10
at mtl.	21,2	240	KMEN6120021	224	-	255	258	262	266	-	319	324	346	-
at mtl.	21,2	240	KMEN7120021	224	-	255	258	262	266	-	319	324	346	-

Lavorazione per fissaggio su schienale (2 supporti) fino L. 75 cm cad. PUNTI15 COD. KMAGMEN54

Machining for fixing on backpanel (2 supports) up to W. 75 cm | Usinage pour fixation sur le dossier (2 supports) jusqu'à L. 75 cm | Mecanizado para fijación en respaldo (2 soportes) hasta L. 75 cm | Bearbeitung zur Befestigung an der Rückenlehne (2 Stützen) bis zu L. 75 cm

Lavorazione per fissaggio su schienale (3 supporti) da L. 75 cm a L. 120 cm cad. PUNTI23 COD. KMAGMEN55

Machining for fixing on backpanel (3 supports) from W. 75 cm to W. 120 cm | Usinage pour fixation sur le dossier (3 supports) de L. 75 cm à L. 120 cm | Mecanizado para fijación en respaldo (3 soportes) de L. 75 cm a L. 120 cm | Bearbeitungen zur Befestigung an der Rückenlehne (3 Stützen) von L. 75 cm bis L. 120 cm

Lavorazione per fissaggio su schienale (4 supporti) da L. 121 cm a L. 240 cm cad. PUNTI30 COD. KMAGMEN56

Machining for fixing on backpanel (4 supports) from W. 121 cm to W. 240 cm | Usinage pour fixation sur le dossier (4 supports) de L. 121 cm à L. 240 cm | Mecanizado para fijación en respaldo (4 soportes) de A. 121 cm a A. 240 cm | Bearbeitungen zur Befestigung an der Rückenlehne (4 Stützen) von B. 121 cm bis B. 240 cm

FRONTALI

Fronts
Façades
Frentes
Fronten

	H/H	L/W	CODICE	0	1	2	3	4	5	6	7	8	9	10
H. 8,9	8,6	59,7	KAN01008060	6	23	22	39	38	18	35	57	97	116	109
	8,6	74,7	KAN01008075	7	25	26	44	38	22	40	65	118	137	133
	8,6	89,7	KAN01008090	8	29	31	50	38	26	47	73	139	154	157
H. 10,5	10,2	59,7	KAN01010060	6	23	24	41	38	21	38	68	102	118	116
	10,2	74,7	KAN01010075	8	26	28	46	38	26	44	75	124	140	141
	10,2	89,7	KAN01010090	9	30	32	51	38	31	52	79	145	156	166
H. 18,7	18,4	44,7	KAN01018045	7	22	25	41	38	27	42	60	100	96	119
	18,4	59,7	KAN01018060	9	26	31	48	38	36	53	75	125	116	151
	18,4	74,7	KAN01018075	11	30	37	55	39	45	64	92	151	138	182
	18,4	89,7	KAN01018090	13	33	43	62	41	55	75	109	175	156	214
	18,4	104,7	KAN01018105	15	37	49	69	48	64	87	127	201	170	246
	18,4	119,7	KAN01018120	17	43	54	75	55	73	98	144	216	189	277
H. 19,5	19,2	44,7	KAN01019045	7	22	26	42	38	28	42	60	102	99	122
	19,2	59,7	KAN01019060	9	26	32	49	38	38	55	77	127	130	154
	19,2	74,7	KAN01019075	11	30	38	56	41	47	66	95	153	140	186
	19,2	89,7	KAN01019090	14	35	44	63	43	57	78	112	178	159	219
	19,2	104,7	KAN01019105	16	40	50	70	50	66	90	130	204	176	251
	19,2	119,7	KAN01019120	18	44	56	77	57	76	101	148	230	191	283
H. 23	22,7	59,7	KAN01023060	11	28	35	52	38	45	62	86	137	135	169
H. 25	24,7	59,7	KAN01025060	11	28	37	54	38	49	66	108	144	138	178
H. 33	32,7	59,7	KAN01033060	14	31	44	61	51	64	81	130	166	166	212
H. 36	35,7	44,7	KAN01036045	12	27	37	53	45	52	67	84	142	144	179
	35,7	59,7	KAN01036060	15	32	46	63	53	70	87	109	175	174	224
	35,7	74,7	KAN01036075	19	37	55	73	66	87	106	134	207	202	269
	35,7	89,7	KAN01036090	22	43	64	83	78	105	126	159	240	228	314
	35,7	104,7	KAN01036105	25	49	73	93	91	122	145	184	273	261	359
	35,7	119,7	KAN01036120	29	54	82	103	104	139	165	208	305	298	404

Basi con maniglia
Base units with handle

Basi con gola
Base units with groove

Colonne
Tall units

Pensili
Wall units

Elementi speciali
Special elements

Maniglie gole zoccoli
Handles grooves plinth

Illuminazione
Lighting

Accessori
Accessories

Componenti e meccanismi
Components e mechanism

FRONTALI

Fronts
Façades
Frentes
Fronten

	H/H	L/W	CODICE	0	1	2	3	4	5	6	7	8	9	10
H. 37,5	37,2	14,7	KAN01037015	5	17	20	35	38	18	30	57	79	77	92
	37,2	44,7	KAN01037045	12	27	38	54	41	55	69	87	145	149	185
	37,2	59,7	KAN01037060	16	33	47	64	55	73	90	113	179	179	231
	37,2	74,7	KAN01037075	19	38	57	75	69	91	109	139	212	206	277
	37,2	89,7	KAN01037090	23	44	66	85	81	109	130	164	245	233	323
	37,2	104,7	KAN01037105	26	50	75	95	95	127	151	190	279	270	369
	37,2	119,7	KAN01037120	30	55	84	105	108	145	171	216	312	311	415
H. 39	38,7	14,7	KAN01039015	5	17	21	36	38	19	31	65	82	74	95
	38,7	44,7	KAN01039045	13	27	39	55	43	57	72	90	149	151	190
	38,7	59,7	KAN01039060	16	33	49	66	57	76	93	117	184	184	237
	38,7	74,7	KAN01039075	20	39	58	76	72	94	113	143	217	210	284
	38,7	89,7	KAN01039090	23	45	68	87	84	113	134	170	251	245	332
	38,7	104,7	KAN01039105	27	51	77	97	98	132	156	196	285	280	379
	38,7	119,7	KAN01039120	31	56	87	108	112	151	177	223	319	320	426
H. 43,5	43,2	44,7	KAN01043045	14	29	42	58	48	63	78	99	160	160	205
	43,2	59,7	KAN01043060	18	35	53	70	64	84	101	128	196	195	256
	43,2	74,7	KAN01043075	22	40	63	81	78	105	124	157	232	224	307
	43,2	89,7	KAN01043090	26	47	73	92	94	126	147	186	268	268	358
	43,2	104,7	KAN01043105	30	54	84	104	110	147	171	216	304	311	409
	43,2	119,7	KAN01043120	34	59	94	115	119	168	194	245	339	355	460
H. 45,5	45,2	14,7	KAN01045015	6	18	22	37	38	22	34	69	92	79	107
	45,2	44,7	KAN01045045	14	29	44	60	50	66	81	103	165	166	212
	45,2	59,7	KAN01045060	18	36	55	72	67	88	105	133	202	200	265
	45,2	74,7	KAN01045075	23	41	65	83	82	105	129	164	238	233	317
	45,2	89,7	KAN01045090	27	48	76	95	98	132	153	194	275	280	369
	45,2	104,7	KAN01045105	31	55	86	106	115	154	178	224	312	324	422
	45,2	119,7	KAN01045120	35	61	97	118	125	176	202	254	348	371	474
	45,2	149,7	KAN01045150	43	71	118	139	156	220	248	315	422	460	579
H. 48	47,7	59,7	KAN01048060	19	36	57	74	69	93	110	138	209	205	275

FRONTALI

Fronts
Façades
Frentes
Fronten

	H/H	L/W	CODICE	0	1	2	3	4	5	6	7	8	9	10
H. 51	50,7	44,7	KAN01051045	16	31	48	64	56	74	89	114	178	179	231
	50,7	59,7	KAN01051060	20	37	59	76	74	99	116	147	217	214	288
	50,7	74,7	KAN01051075	25	44	71	89	92	123	142	181	256	258	345
	50,7	89,7	KAN01051090	30	51	83	102	110	148	169	214	295	308	401
	50,7	104,7	KAN01051105	34	58	94	114	123	173	196	248	335	362	458
	50,7	119,7	KAN01051120	39	64	106	127	140	197	223	281	374	411	515
H. 57	56,7	14,7	KAN01057015	7	19	27	42	38	28	39	59	110	79	129
	56,7	28,1	KAN01057028	12	25	38	53	51	52	65	84	147	152	184
	56,7	30,5	KAN01057031	13	26	40	55	55	57	70	112	154	165	194
	56,7	44,7	KAN01057045	17	32	52	68	63	83	98	126	194	191	252
	56,7	49,7	KAN01057049	19	34	56	72	70	92	107	138	207	204	273
	56,7	59,7	KAN01057060	22	40	65	82	82	110	127	163	235	231	313
	56,7	74,7	KAN01057075	28	46	77	95	103	138	157	200	276	287	375
	56,7	89,7	KAN01057090	33	54	90	109	118	165	186	236	318	343	436
	56,7	104,7	KAN01057105	38	62	103	123	137	193	216	273	359	399	498
	56,7	119,7	KAN01057120	43	68	115	136	157	220	246	310	401	456	559
	56,7	149,7	KAN01057150	53	81	141	163	191	275	303	384	485	567	682
H. 58,5	58,2	14,7	KAN01058015	8	19	27	42	38	28	40	79	112	78	132
	58,2	29,7	KAN01058030	13	26	40	55	43	57	70	92	155	149	195
	58,2	44,7	KAN01058045	18	33	53	69	65	85	100	129	196	195	257
	58,2	59,7	KAN01058060	23	40	66	83	84	113	130	167	239	238	320
	58,2	74,7	KAN01058075	28	47	79	97	105	141	160	204	281	293	382
	58,2	89,7	KAN01058090	33	54	92	111	121	170	191	242	324	353	445
	58,2	104,7	KAN01058105	38	62	105	125	141	198	221	280	365	409	507
	58,2	119,7	KAN01058120	44	69	118	139	161	226	252	317	408	468	570
H. 63	62,7	14,7	KAN01063015	8	20	29	44	38	31	42	60	119	79	141
	62,7	29,7	KAN01063030	14	27	42	57	46	61	74	98	164	155	207
	62,7	44,7	KAN01063045	19	34	56	72	69	91	106	138	208	204	273
	62,7	59,7	KAN01063060	25	42	70	87	91	122	139	178	252	253	339
	62,7	74,7	KAN01063075	30	49	84	102	113	152	171	218	296	315	405
H. 69	68,7	44,7	KAN01069045	21	36	60	76	74	100	115	150	223	213	294

Basi con maniglia
Base units with handle

Basi con gola
Base units with groove

Colonne
Tall units

Pensili
Wall units

Elementi speciali
Special elements

Maniglie gole zoccoli
Handles grooves plinth

Illuminazione
Lighting

Accessori
Accessories

Componenti e meccanismi
Components e mechanism

FRONTALI

Fronts
Façades
Frentes
Fronten

	H/H	L/W	CODICE	0	1	2	3	4	5	6	7	8	9	10
H. 72	71,7	14,7	KAN01072015	9	21	32	47	38	35	47	77	134	110	158
	71,7	28,1	KAN01072028	15	28	46	61	50	66	79	106	176	164	223
	71,7	29,7	KAN01072030	15	29	47	62	53	70	83	111	182	169	231
	71,7	30,5	KAN01072031	16	29	48	64	54	72	85	113	185	172	235
	71,7	44,7	KAN01072045	22	36	63	79	78	105	119	156	230	219	304
	71,7	49,7	KAN01072049	24	39	68	84	86	116	131	171	245	241	329
	71,7	59,7	KAN01072060	28	45	78	95	104	139	156	201	277	288	377
	71,7	74,7	KAN01072075	34	53	93	111	124	174	193	247	325	359	450
H. 78	77,7	14,7	KAN01078015	10	22	34	49	38	38	50	83	143	124	196
	77,7	29,7	KAN01078030	17	30	50	65	57	76	89	119	194	179	247
	77,7	35	KAN01078035	19	33	56	72	68	89	103	137	212	198	275
	77,7	37,5	KAN01078037	20	34	59	75	72	95	109	145	220	206	288
	77,7	44,7	KAN01078045	23	38	67	83	84	113	128	168	245	235	325
	77,7	59,7	KAN01078060	30	47	83	100	113	151	168	217	295	310	403
	77,7	74,7	KAN01078075	36	55	100	118	134	188	207	265	345	388	480
	H. 87	86,7	14,7	KAN01087015	11	23	37	52	38	42	54	92	157	123
86,7		28,1	KAN01087028	18	31	53	68	60	80	93	127	194	184	262
86,7		29,7	KAN01087030	18	31	55	70	64	84	97	132	200	191	271
86,7		30,5	KAN01087031	19	32	56	72	65	87	100	135	202	194	276
86,7		44,7	KAN01087045	26	40	73	89	94	126	141	186	251	260	356
86,7		49,7	KAN01087049	28	43	79	95	104	140	155	204	285	289	384
86,7		59,7	KAN01087060	33	50	91	108	120	168	185	240	321	345	441
86,7		74,7	KAN01087075	40	59	109	127	150	210	229	294	375	429	526
H. 99	98,7	44,7	KAN01099045	29	44	82	98	107	144	158	210	295	295	398
	98,7	59,7	KAN01099060	37	54	102	119	136	191	208	271	355	389	492
H. 102	101,7	14,7	KAN01102015	13	24	42	57	42	50	61	108	181	148	215
	101,7	28,1	KAN01102028	20	33	61	76	71	94	107	147	235	215	302
	101,7	29,7	KAN01102030	21	34	63	78	73	99	112	154	242	221	312
	101,7	30,5	KAN01102031	22	35	64	80	75	101	115	157	243	224	317
	101,7	44,7	KAN01102045	30	45	84	100	110	148	163	216	303	311	408
	101,7	49,7	KAN01102049	33	48	91	107	116	164	180	237	323	346	440
	101,7	59,7	KAN01102060	38	55	104	121	140	197	214	278	364	409	505
	101,7	74,7	KAN01102075	47	65	125	143	171	246	265	341	425	503	601

FRONTALI

Fronts
Façades
Frentes
Fronten

	H/H	L/W	CODICE	0	1	2	3	4	5	6	7	8	9	10
H. 117	116,7	14,7	KAN01117015	15	26	47	62	43	57	69	112	205	129	244
	116,7	29,7	KAN01117030	24	37	71	86	84	113	126	175	272	247	352
	116,7	44,7	KAN01117045	34	49	94	110	121	170	185	246	339	358	460
	116,7	59,7	KAN01117060	43	61	118	135	161	226	243	317	406	468	568
	116,7	74,7	KAN01117075	53	72	141	159	197	283	301	388	474	578	676
H. 120	119,7	59,7	KAN01120060	45	62	120	137	161	232	249	325	415	478	581
H. 132	131,7	14,7	KAN01132015	16	28	53	68	56	64	76	127	228	159	273
	131,7	29,7	KAN01132030	27	40	79	94	95	128	141	196	302	278	393
	131,7	44,7	KAN01132045	38	53	105	121	136	191	206	276	375	401	512
	131,7	59,7	KAN01132060	49	66	131	148	177	255	272	356	449	527	632
	131,7	64,7	KAN01132065	52	70	139	157	192	276	294	382	474	568	672
	131,7	74,7	KAN01132075	60	78	157	175	222	319	337	435	523	650	752
	131,7	79,7	KAN01132080	63	83	166	185	237	340	360	462	547	691	792
H. 147	146,7	14,7	KAN01147015	18	30	58	73	52	72	83	113	252	157	302
	146,7	29,7	KAN01147030	30	43	87	102	106	142	156	218	332	308	433
	146,7	44,7	KAN01147045	42	57	115	131	152	213	228	306	412	447	564
	146,7	59,7	KAN01147060	54	71	144	161	197	284	301	394	492	585	696
	146,7	74,7	KAN01147075	66	85	173	191	247	355	374	482	572	724	827
H. 162	161,7	14,7	KAN01162015	20	32	63	78	58	79	90	127	275	171	330
	161,7	29,7	KAN01162030	33	46	94	109	116	157	170	239	362	339	473
	161,7	44,7	KAN01162045	46	61	126	142	163	235	250	336	448	491	616
	161,7	59,7	KAN01162060	59	76	157	174	218	313	330	433	535	645	759
	161,7	74,7	KAN01162075	72	91	189	207	272	391	410	529	621	796	902
H. 195	194,7	14,7	KAN01195015	24	36	75	90	73	95	106	147	326	210	393
	194,7	29,7	KAN01195030	40	53	112	127	134	189	202	286	427	402	562
	194,7	44,7	KAN01195045	55	70	149	165	196	283	298	402	528	588	731
	194,7	59,7	KAN01195060	71	88	186	203	262	377	394	518	629	771	899
	194,7	64,7	KAN01195065	76	93	199	216	284	408	425	556	663	831	956
	194,7	74,7	KAN01195075	86	105	224	242	328	471	489	633	730	951	1.068
	194,7	79,7	KAN01195080	92	111	236	254	350	502	521	672	764	1.016	1.124

Basi con maniglia
Base units with handle

Basi con gola
Base units with groove

Colonne
Tall units

Pensili
Wall units

Elementi speciali
Special elements

Maniglie gole zoccoli
Handles grooves plinth

Illuminazione
Lighting

Accessori
Accessories

Componenti e meccanismi
Components e mechanism

FRONTALI

Fronts
Façades
Frentes
Fronten

	H/H	L/W	CODICE	0	1	2	3	4	5	6	7	8	9	10
H. 210	209,7	14,7	KAN01210015	26	37	80	95	79	102	114	159	350	225	422
	209,7	29,7	KAN01210030	42	56	120	135	144	203	216	307	457	437	602
	209,7	44,7	KAN01210045	59	74	160	176	211	304	319	432	565	636	783
	209,7	59,7	KAN01210060	76	93	200	217	282	406	423	556	672	834	963
	209,7	64,7	KAN01210065	82	99	213	231	306	439	457	598	707	900	1.023
	209,7	74,7	KAN01210075	93	112	239	257	353	507	526	680	779	1.033	1.143
	209,7	79,7	KAN01210080	98	117	253	272	377	540	560	722	815	1.099	1.204
H. 225	224,7	14,7	KAN01225015	27	39	85	100	74	109	121	165	374	238	451
	224,7	29,7	KAN01225030	45	59	128	143	154	218	231	329	487	467	643
	224,7	44,7	KAN01225045	63	78	170	186	227	326	341	462	600	678	835
	224,7	59,7	KAN01225060	81	98	213	230	302	434	452	595	715	893	1.027
	224,7	64,7	KAN01225065	87	105	227	245	328	471	488	639	753	962	1.091
	224,7	74,7	KAN01225075	99	118	255	273	378	543	562	728	828	1.104	1.219
	224,7	79,7	KAN01225080	105	124	270	289	404	579	598	772	866	1.176	1.283
H. 240	239,7	14,7	KAN01240015	29	41	90	105	84	117	128	170	397	247	479
	239,7	29,7	KAN01240030	48	62	135	150	161	232	245	350	517	499	683
	239,7	44,7	KAN01240045	67	82	181	197	242	348	363	492	637	726	887
	239,7	59,7	KAN01240060	87	104	226	243	323	464	481	633	757	953	1.090
	239,7	64,7	KAN01240065	93	110	241	259	350	502	520	680	797	1.028	1.158
	239,7	74,7	KAN01240075	106	124	271	289	404	579	598	775	877	1.180	1.294
	239,7	79,7	KAN01240080	112	131	286	305	431	618	637	822	918	1.255	1.362
H. 275	274,7	147	KAN01275015	43	68	102	120	93	134	159	282	452	295	632
	274,7	297	KAN01275030	66	91	154	172	175	266	291	400	587	525	867
	274,7	447	KAN01275045	90	113	205	223	263	399	423	562	723	753	1.102
	274,7	597	KAN01275060	114	136	257	275	351	531	555	723	858	986	1.338
	274,7	747	KAN01275075	138	159	308	326	439	664	688	885	993	1.210	1.573

CERNIERE

Hinges
Charnières
Bisagras
Scharniere

Cerniera con rallentatore + basetta per anta dx/sx

Hinge with slow motion + baseplate for right/left door
Charnière ralentie + embase pour porte droite/gauche
Bisagra con retardador + placa para puerta derecha/izquierda
Scharnier mit Softeinzug + Grundplatte für rechte/linke Tür

Per ante sp. 1,6 / 2,2 cm
For 1.6 / 2.2 cm thick doors
Pour les portes de 1,6 / 2,2 cm d'épaisseur
Para puertas de 1,6 / 2,2 cm de grosor
Für 1,6 / 2,2 cm dicke Türen

CODICE	PUNTI
KCER1ABA	6

Cerniera con rallentatore + basetta per anta base angolo, pensile angolo lineare, colonna angolo

Hinge with slow motion + base plate for corner base cabinet door, linear corner wall unit, corner tall unit
Charnière ralentie + embase pour porte de base d'angle, meuble haut d'angle linéaire, colonne d'angle
Bisagra con retardador + placa para puerta de base ángulo, colgante ángulo, columna ángulo
Scharnier mit Softeinzug + Grundplatte für Eckunterschranktür, lineare Eckschrankwand, Eckhochschrank

Per ante sp. 1,6 / 2,2 cm
For 1.6 / 2.2 cm thick doors
Pour les portes de 1,6 / 2,2 cm d'épaisseur
Para puertas de 1,6 / 2,2 cm de grosor
Für 1,6 / 2,2 cm dicke Türen

CODICE	PUNTI
KCERIAAN	10

Cerniera con rallentatore + basetta per anta basculante superiore

Hinge with slow motion + baseplate for upper up-and-over door
Charnière ralentie + embase pour porte basculante supérieure
Bisagra con retardador + placa para puerta basculante superior
Scharnier mit Softeinzug + Grundplatte für oberes Klapptür

Per ante sp. 1,6 / 2,2 cm
For 1.6 / 2.2 cm thick doors
Pour les portes de 1,6 / 2,2 cm d'épaisseur
Para puertas de 1,6 / 2,2 cm de grosor
Für 1,6 / 2,2 cm dicke Türen

CODICE	PUNTI
KCER1ABS	4

Cerniera con rallentatore + basetta per anta basculante inferiore

Hinge with slow motion + base plate for lower up-and-over door
Charnière ralentie + embase pour porte basculante inférieure
Bisagra con retardador + placa para puerta basculante inferior
Scharnier mit Softeinzug + Grundplatte für unteres Klapptür

Per ante sp. 1,6 / 2,2 cm
For 1.6 / 2.2 cm thick doors
Pour les portes de 1,6 / 2,2 cm d'épaisseur
Para puertas de 1,6 / 2,2 cm de grosor
Für 1,6 / 2,2 cm dicke Türen

CODICE	PUNTI
KCER1ABI	7

Cerniera con rallentatore + basetta per anta 155° pensile scolapiatti, base/pensili angolo ante indipendenti, base/colonna kit cassetti/cestoni interni

Hinge with slow motion + base unit for 155° door Dish drainer wall unit, base/corner unit freestanding doors, base/corner unit internal drawer/basket kit
Charnière avec ralentisseur + élément bas pour porte 155° Evier à vaisselle élément mural, élément bas/encastré portes indépendantes, élément bas/ encastré kit tiroir intérieur/panier
Bisagra con retardador + placa para puerta 155° Colgante escurridor de platos, base/colgante ángulo puertas independientes, base/columna juego de cajones/cestas interiores
Scharnier mit Softeinzug + Grundplatte für 155°-Tür Geschirrspültür-Hängeschrank, Unterschrank/Eckschrank freistehende Türen, Unterschrank/Eckschrank Innenschubkasten/Schubkastbausatz

Per ante sp. 1,6 / 2,2 cm
For 1.6 / 2.2 cm thick doors
Pour les portes de 1,6 / 2,2 cm d'épaisseur
Para puertas de 1,6 / 2,2 cm de grosor
Für 1,6 / 2,2 cm dicke Türen

CODICE	PUNTI
KCER1ASK	16

Cerniera senza rallentatore + basetta per anta colonna frigo

Hinge without slow motion + base plate for refrigerator door tall units
Charnière ralentie + embase pour porte colonne frigo
Bisagra sin retardador + placa para puerta de columna nevera
Scharnier ohne Softeinzug + Grundplatte für Kühlschrank-Hochschrank

Per ante sp. 1,6 / 2,2 cm
For 1.6 / 2.2 cm thick doors
Pour les portes de 1,6 / 2,2 cm d'épaisseur
Para puertas de 1,6 / 2,2 cm de grosor
Für 1,6 / 2,2 cm dicke Türen

CODICE	PUNTI
KCER1AFR	4

Basi con maniglia
Base units with handle

Basi con gola
Base units with groove

Colonne
Tall units

Pensili
Wall units

Elementi speciali
Special elements

Maniglie gole zoccoli
Handles grooves plinth

Illuminazione
Lighting

Accessori
Accessories

Componenti e meccanismi
Components e mechanism

STRUTTURE CASSETTI E CESTONI

Drawer and basket structures
Structures de tiroirs et de paniers
Estructuras de cajones y cestas
Schubladen- und Schubkaststrukturen

Cassetto interno H. 10 con guide per basi e colonne

Internal drawer H 10 with slides for base and tall units
Tiroir interne H 10 avec glissières pour bases et colonnes
Cajón interior H 10 con guías para armarios bases y columnas
Innenschubladen H 10 für Unter- und Hochschränke

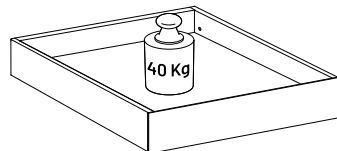

Non riducibile in larghezza
Not reducible in width
Largeur non réductible
No se puede reducir en anchura
Breitverkürzung nicht möglich

P/D	L/W	CODICE	PUNTI
50	45	KSC0404550010	121
50	60	KSC0406050010	127
50	75	KSC0407550010	139
50	90	KSC0409050010	139
50	105	KSC0410550010	152
50	120	KSC0412050010	152
60	45	KSC0404560010	128
60	60	KSC0406060010	134
60	75	KSC0407560010	150
60	90	KSC0409060010	150
60	105	KSC0410560010	162
60	120	KSC0412060010	162

Cestone interno H. 19 con guide per basi e colonne

H 19 inner basket with slides for base and tall units
Panier intérieur H 19 avec coulisses pour bases et colonnes
Cajón interior H 19 con guías basa bases y columnas
Innenschubkasten H 19 Unter- und Hochschrankauszug

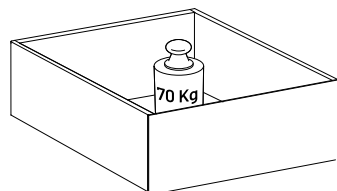

Non riducibile in larghezza
Not reducible in width
Largeur non réductible
No se puede reducir en anchura
Breitverkürzung nicht möglich

P/D	L/W	CODICE	PUNTI
50	45	KSC0504550018	168
50	60	KSC0506050018	178
50	75	KSC0507550018	199
60	45	KSC0504560018	180
60	60	KSC0506060018	192
60	75	KSC0507560018	216

Cassetto H. 10 con guide senza frontale

H 10 drawer with slides without front panel
Tiroir H 10 avec glissières sans façade
Cajón H 10 con guías sin frente
Schublade H 10 mit Schienen ohne Front

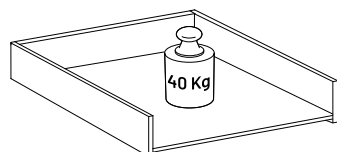

P/D	L/W	CODICE	PUNTI
50	45	KSC0204550010	94
50	60	KSC0206050010	97
50	75	KSC0207550010	104
50	90	KSC0209050010	104
50	105	KSC0210550010	108
50	120	KSC0212050010	108
60	45	KSC0204560010	101
60	60	KSC0206060010	104
60	75	KSC0207560010	112
60	90	KSC0209060010	112
60	105	KSC0210560010	117
60	120	KSC0212060010	117

STRUTTURE CASSETTI E CESTONI

Drawer and basket structures
Structures de tiroirs et de paniers
Estructuras de cajones y cestas
Schubladen- und Schubkaststrukturen

Cestone H. 13 con guide senza frontale

H 13 basket with rails without front panel
Panier H 13 avec glissières sans façade
H 13 cajón con guías sin panel frontal
H 13 Schubkast ohne Frontblende

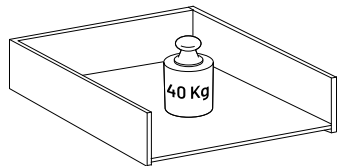

P/D	L/W	CODICE	PUNTI
50	45	KSC0104550013	102
50	60	KSC0106050013	105
50	75	KSC0107550013	112
50	90	KSC0109050013	112
50	105	KSC0110550013	117
50	120	KSC0112050013	117
60	45	KSC0104560013	109
60	60	KSC0106060013	112
60	75	KSC0107560013	121
60	90	KSC0109060013	121
60	105	KSC0110560013	126
60	120	KSC0112060013	126

Cestone H. 19 con guide senza frontale

H 19 basket with rails without front panel
Panier H 19 avec glissières sans façade
H 19 cajón con guías sin panel frontal
H 19 Schubkast ohne Frontblende

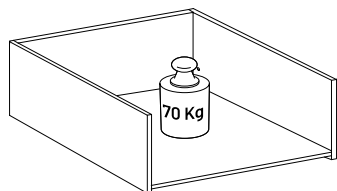

P/D	L/W	CODICE	PUNTI
50	45	KSC0104550018	127
50	60	KSC0106050018	130
50	75	KSC0107550018	138
50	90	KSC0109050018	138
50	105	KSC0110550018	143
50	120	KSC0112050018	143
60	45	KSC0104560018	141
60	60	KSC0106060018	144
60	75	KSC0107560018	153
60	90	KSC0109060018	153
60	105	KSC0110560018	159
60	120	KSC0112060018	159

Cestone H. 24 con guide senza frontale

H 24 basket with rails without front panel
Panier H 24 avec glissières sans façade
H 24 cesta con guías sin panel frontal
H 24 Schubkast ohne Frontende

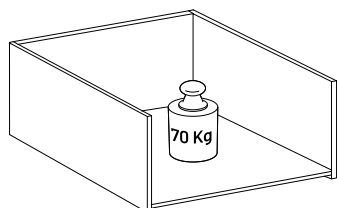

P/D	L/W	CODICE	PUNTI
50	45	KSC0104550025	149
50	60	KSC0106050025	151
50	75	KSC0107550025	160
50	90	KSC0109050025	160
50	105	KSC0110550025	166
50	120	KSC0112050025	166
60	45	KSC0104560025	164
60	60	KSC0106060025	167
60	75	KSC0107560025	176
60	90	KSC0109060025	176
60	105	KSC0110560025	182
60	120	KSC0112060025	182

Basi con maniglia
Base units with handle

Basi con gola
Base units with groove

Colonne
Tall units

Pensili
Wall units

Elementi speciali
Special elements

Maniglie gole zoccoli
Handles grooves plinth

Illuminazione
Lighting

Accessori
Accessories

Componenti e meccanismi
Components e mechanism

STRUTTURE CASSETTI E CESTONI

Drawer and basket structures
Structures de tiroirs et de paniers
Estructuras de cajones y cestas
Schubladen- und Schubkaststrukturen

Cestone sagomato H. 13 con guide senza frontale

H 13 shaped basket with rails without front panel

Panier galbé H 13 avec coulisses sans façade

H 13 cajón perfilado con guías sin frente

H 13 Formschublade mit Führungsschienen ohne Frontblende

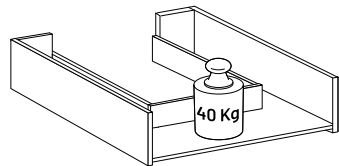

P/D	L/W	CODICE	PUNTI
50	75	KSC0307550013	195
50	90	KSC0309050013	195
50	105	KSC0310550013	206
50	120	KSC0312050013	206

SISTEMI DI APERTURA PER ANTE

Door opening systems
Systèmes d'ouverture des portes
Sistemas de apertura para puertas
Türöffnungssysteme

Sistema vasistas

Vasistas system
Système vasistas
Sistema Abatible
Vasistasystem

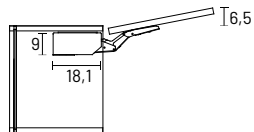

FORZA	CODICE	PUNTI
K23	KMV01K23	81
K25	KMV01K25	81
K27	KMV01K27	81
K29	KMV01K29	94

Sistema saliscendi H. 57

H. 57 up-and-down system
Système coulissant H. 57
Sistema deslizante H. 57
Schiebesystem H. 57

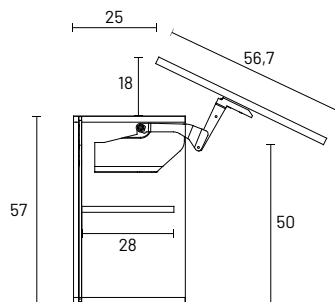

H/H	CODICE	PUNTI
57	KMS01S2D	137
57	KMS01S2E	145
57	KMS01S2F	199

Sistema basculante H. 72

H. 72 overhead system
Système aérien H. 72
Sistema basculante H. 72
Überkopfsystem H. 72

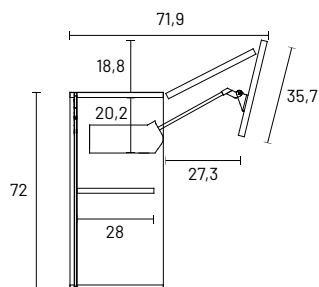

H/H	CODICE	PUNTI
72	KMB01F22	132

Basi con maniglia
Base units with handle

Basi con gola
Base units with groove

Colonne
Tall units

Pensili
Wall units

Elementi speciali
Special elements

Maniglie gole zoccoli
Handles grooves plinth

Illuminazione
Lighting

Accessori
Accessories

Componenti e meccanismi
Components e mechanism

SISTEMI DI APERTURA PER ANTE

Door opening systems
Systèmes d'ouverture des portes
Sistemas de apertura para puertas
Türöffnungssysteme

Sistema basculante H. 87

H. 87 overhead system
Système aérien H. 87
Sistema basculante H. 87
Überkopfsystem H. 87

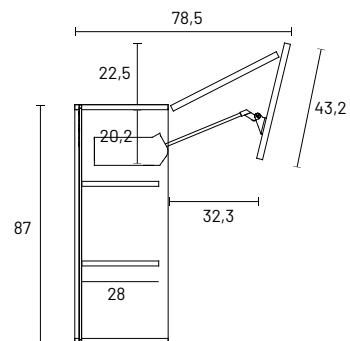

H/H	CODICE	PUNTI
87	KMB01F25	136

Sistema basculante H. 102

H. 102 overhead system
Système aérien H. 102
Sistema basculante H. 102
Überkopfsystem H. 102

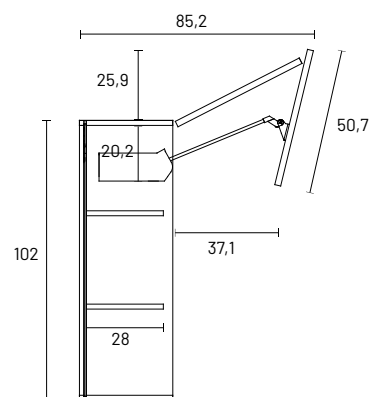

H/H	CODICE	PUNTI
102	KMB01F28	144

RIPIANI IN FINITURA SCOCCA

Shelves in shell finish
Étagères en finition structure
Estantes en acabado estructura
Fachböden in Muscheloptik

Ripiano base P. 57

Base shelf D 57
Étagère de base P 57
Estante base P 57
Fachboden T 57

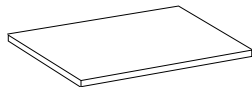

Cenere, grafite
Ash, graphite
Cendre, graphite
Ceniza, grafito

Cenere, grafite (NON SI TRADUCE)

	P/D	L/W	CODICE	PUNTI
L. 15	47,5	11,3	KRP0101104718	7
L. 30	47,5	26,3	KRP0102604718	12
L. 45	47,5	41,3	KRP0104104718	15
L. 60	47,5	56,3	KRP0105604718	18
L. 75	47,5	71,3	KRP0107104718	20
L. 90	47,5	86,3	KRP0108604718	22
L. 105	47,5	101,3	KRP0110104718	24
L. 120	47,5	116,3	KRP0111604718	28
angolo corner L. 95	88,3	88,3	KRP0308808818	39

Ripiano base P. 67

Base shelf D 67
Étagère de base P 67
Estante base P 67
Fachboden T 67



Cenere, grafite
Ash, graphite
Cendre, graphite
Ceniza, grafito

Cenere, grafite (NON SI TRADUCE)

	P/D	L/W	CODICE	PUNTI
L. 15	57,5	11,3	KRP0101105718	7
L. 30	57,5	26,3	KRP0102605718	12
L. 45	57,5	41,3	KRP0104105718	15
L. 60	57,5	56,3	KRP0105605718	18
L. 75	57,5	71,3	KRP0107105718	20
L. 90	57,5	86,3	KRP0108605718	22
L. 105	57,5	101,3	KRP0110105718	24
L. 120	57,5	116,3	KRP0111605718	28
angolo corner L. 105	98,3	98,3	KRP0309809818	41

Ripiano pensile

Hanging shelf
Étagère suspendue
Estante colgante
Fachboden für Hängeschrank



Cenere, grafite
Ash, graphite
Cendre, graphite
Ceniza, grafito

Cenere, grafite (NON SI TRADUCE)

	P/D	L/W	CODICE	PUNTI
L. 15	28	11,3	KRP0101102818	12
L. 30	28	26,3	KRP0102602818	12
L. 45	28	41,3	KRP0104102818	12
L. 60	28	56,3	KRP0105602818	15
L. 75	28	71,3	KRP0107102818	15
L. 90	28	86,3	KRP0108602818	18
L. 105	28	101,3	KRP0110102818	18
L. 120	28	116,3	KRP0111602818	22
angolo corner L. 65	60,6	60,6	KRP0306006018	22

Basi con maniglia
Base units with handle

Basi con gola
Base units with groove

Colonne
Tall units

Pensili
Wall units

Elementi speciali
Special elements

Maniglie gole zoccoli
Handles grooves plinth

Illuminazione
Lighting

Accessori
Accessories

Componenti e meccanismi
Components e mechanism

RIPIANI IN FINITURA SCOCCA

Shelves in shell finish
Étagères en finition structure
Estantes en acabado estructura
Fachböden in Muscheloptik

Profilo copribordo sp. 2,9

Edge cover profile 2.9 mm
Profilé de recouvrement des bords 2,9 mm
Perfil para borde 2,9 mm
Kantenabdeckung 2,9 mm

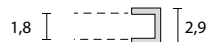

Alluminio nero
Black aluminum
Aluminium noir
Aluminio negro
Schwarzes Aluminium

	CODICE	PUNTI	
	L. 15	KPRR1011	4
	L. 30	KPRR1026	4
	L. 45	KPRR1041	6
	L. 60	KPRR1056	10
	L. 75	KPRR1071	10
	L. 90	KPRR1086	12
	L. 95	KPRR1091	12
	L. 105	KPRR1101	14
	L. 120	KPRR1116	16
angolo corner	L. 65	KPRR1065	17
angolo corner	L. 95	KPRR1095	25
angolo corner	L. 105	KPRR1105	27

RIPIANI IN VETRO

Glass shelves
Étagères en verre
Estantes de cristal
Glasböden

Ripiano pensile grigio fumè

Smoked gray hanging shelf
Étagère suspendue gris fumé
Estante colgante gris ahumado
Fachboden für Hängeschrank grigio fumè

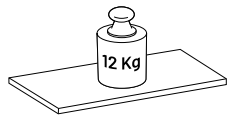

Comprendo di reggiripiani color brunito
Including burnished shelf brackets
Y compris les supports d'étagères brunis
Incluye soportes para estantes acabado bruñido
Einschließlich brünierter Regalstützen

	P/D	L/W	CODICE	PUNTI
L. 45	28	40,5	KRP1104002808	18
L. 60	28	55,5	KRP1105502808	21
L. 75	28	70,5	KRP1107002808	27
L. 90	28	85,5	KRP1108502808	32
L. 105	28	100,5	KRP1110002808	38
L. 120	28	115,5	KRP1111502808	44

Ripiano base P. 57 grigio fumè

Base shelf D 57 smoked gray
Étagère de base P 57 gris fumé
Estante base P 57 gris ahumado
Fachboden T 57 rauchgrau

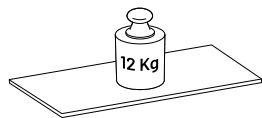

Comprendo di reggiripiani color brunito
Including burnished shelf brackets
Y compris les supports d'étagères brunis
Incluye soportes para estantes acabado bruñido
Einschließlich brünierter Regalstützen

	P/D	L/W	CODICE	PUNTI
L. 45	47,5	41,3	KRP1104104708	26
L. 60	47,5	56,3	KRP1105604708	35
L. 75	47,5	71,3	KRP1107104708	44
L. 90	47,5	86,3	KRP1108604708	52
L. 105	47,5	101,3	KRP1110104708	62
L. 120	47,5	116,3	KRP1111604708	71

Basi con maniglia
Base units with handle

Basi con gola
Base units with groove

Colonne
Tall units

Pensili
Wall units

Elementi speciali
Special elements

Maniglie gole zoccoli
Handles grooves plinth

Illuminazione
Lighting

Accessori
Accessories

Componenti e meccanismi
Components e mechanism

DIVISIONI IN FINITURA SCOCCA

Body finish divisions
Divisions de la finition du corps
Divisorios acabado como estructura
Trennwand in korpus Ausführungen

Divisione base P. 57

Base units division D 57
Division de base P 57
Divisorio básico P 57
Trennwand T 57



Cenere, grafite
Ash, graphite
Cendre, graphite
Ceniza, grafito
Cenere, grafite (NON SI TRADUCE)

	P/D	L/W	CODICE	PUNTI
L. 15	52,1	11,5	KDV0101105218	15
L. 30	52,1	26,5	KDV0102605218	15
L. 45	52,1	41,5	KDV0104105218	15
L. 60	52,1	56,5	KDV0105605218	18
L. 75	52,1	71,5	KDV0107105218	18
L. 76	52,1	72,5	KDV0107205218	18
L. 90	52,1	86,5	KDV0108605218	18
L. 105	52,1	101,5	KDV0110105218	23
L. 120	52,1	116,5	KDV0111605218	23

Divisione base P. 67

Base unit division D 67
Division de base P 67
Divisorio básico P 67
Trennwand T 67

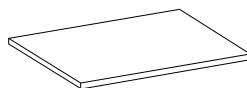

Cenere, grafite
Ash, graphite
Cendre, graphite
Ceniza, grafito
Cenere, grafite (NON SI TRADUCE)

	P/D	L/W	CODICE	PUNTI
L. 15	62,1	11,5	KDV0101106218	15
L. 30	62,1	26,5	KDV0102606218	15
L. 45	62,1	41,5	KDV0104106218	15
L. 60	62,1	56,5	KDV0105606218	18
L. 75	62,1	71,5	KDV0107106218	18
L. 76	62,1	72,5	KDV0107206218	18
L. 90	62,1	86,5	KDV0108606218	18
L. 105	62,1	101,5	KDV0110106218	24
L. 120	62,1	116,5	KDV0111606218	24

Divisione pensile

Hanging division
Division de l'accrochage
Divisorio colgante
Trennwand Hängeschrank

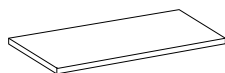

Cenere, grafite
Ash, graphite
Cendre, graphite
Ceniza, grafito
Cenere, grafite (NON SI TRADUCE)

	P/D	L/W	CODICE	PUNTI
L. 15	31,5	11,5	KDV0101102918	12
L. 30	31,5	26,5	KDV0102602918	12
L. 45	31,5	41,5	KDV0104102918	12
L. 60	31,5	56,5	KDV0105602918	15
L. 75	31,5	71,5	KDV0107102918	15
L. 90	31,5	86,5	KDV0108602918	15
L. 105	31,5	101,5	KDV0110102918	19
L. 120	31,5	116,5	KDV0111602918	19

ATTREZZATURE PER MOBILI

Furniture equipment
 Equipement des meubles
 Equipamiento para mobiliario
 Möbelausstattung

Vassoio alluminio per base lavello

Aluminium tray for sink base
 Plateau en aluminium pour la base de l'évier
 Bandeja de aluminio para base fregadero
 Aluminiumschale für Spülenschränke

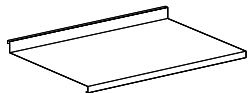

P/D	L/W	CODICE	PUNTI
51,5	41,3	KVL0104105118	13
51,5	56,3	KVL0105605118	15
51,5	71,3	KVL0107105118	19
51,5	86,3	KVL0108605118	20
51,5	101,3	KVL0110105118	22
51,5	116,3	KVL0111605118	24

Rastrelliera inox 1 livello

Stainless steel rack 1 level
 Étagère en acier inoxydable à 1 niveau
 Rejilla de acero inoxidable 1 nivel
 Edelstahlregal 1 Ebene



Per pensili scolapiatti H 39/45,5 cm
 For draining wall units H 39/45,5 cm
 Pour l'évacuation des unités murales H 39/45,5 cm
 Para escurrir armarios altos H 39/45,5 cm
 Für Hängeschränke mit Abtropfflächen H 39/45,5 cm

L/W	CODICE	PUNTI
41,3	KTS20041033	105
56,3	KTS20056033	116
71,3	KTS20071033	138
86,3	KTS20086033	144
101,3	KTS20101033	198
116,3	KTS20116033	198

Rastrelliera inox 2 livelli

2-storey stainless steel rack
 Rack en acier inoxydable à 2 étages
 Rejilla de acero inoxidable 2 niveles
 2-stöckiges Regal aus rostfreiem Stahl



Portapiatti, portabicchieri con raccogli gocce e telaio
 Dish rack, cup holder with drip catcher and frame
 Porte-assiettes, porte-verre avec égouttoir et cadre
 Rejilla para platos, vasos con bandeja recogegotas y marco
 Tellerablage, Glashalter mit Tropfschale und Rahmen

L/W	CODICE	PUNTI
41,3	KTS21041033	102
56,3	KTS21056033	118
71,3	KTS21071033	127
86,3	KTS21086033	147
101,3	KTS21101033	284
116,3	KTS21116033	284

Basi con maniglia
 Base units with handle

Basi con gola
 Base units with groove

Colonne
 Tall units

Pensili
 Wall units

Elementi speciali
 Special elements

Maniglie gole zoccoli
 Handles grooves plinth

Illuminazione
 Lighting

Accessori
 Accessories

Componenti e meccanismi
 Components e mechanism

MECCANISMI SIGE

Sige Mechanisms
Mécánismes Sige
Mecanismos Sige
Sige Mechanismen

Carrello estraibile antracite per base L. 15 cm

Base unit anthracite pull-out W 15 cm
Chariot coulissant pour base L 15 cm
Carrito extraíble para base L 15 cm
Apothekerschrank für B15 cm Unterschrank

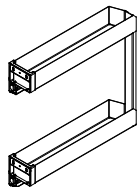

Estrazione totale e chiusura soft
Full extraction and soft closing
Sortie totale et fermeture amortie
Extracción total y cierre suave
vollauszug und Soft Close

	CODICE	PUNTI
antracite	KMC0108SIG	131

Carrello estraibile antracite per base L. 30 cm

Base unit anthracite pull-out W 30 cm
Chariot coulissant pour base L 30 cm
Carrito extraíble para base L 30 cm
Apothekerschrank fuer B 30 cm Unterschrank

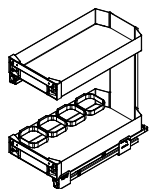

Estrazione totale e chiusura soft
Full extraction and soft closing
Sortie totale et fermeture amortie
Extracción total y cierre suave
vollauszug und Soft Close

	CODICE	PUNTI
antracite	KMC0224SIG	200

Meccanismo slidecorner per base angolo

Slidecorner mechanism for corner base unit
Mécánisme Slidecorner pour base d'angle
Mecanismo slidecorner para base ángulo
Slidecorner-Mechanismus für Eckunterschrank

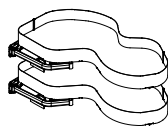

2 cesti estraibili con fondo
2 removable baskets with bottom
2 paniers extractibles avec fond
2 cestas extraíbles con fondo
2 Schubkasten mit Boden

	L/W	CODICE	PUNTI
dx	90	KMA0180BSIGD	581
sx	90	KMA0180BSIGS	581
dx	105	KMA0190BSIGD	611
sx	105	KMA0190BSIGS	611

MECCANISMI SIGE

Sige Mechanisms
Mécánismes Sige
Mecanismos Sige
Sige Mechanismen

Meccanismo slidecorner per colonna angolo

Corner tall units slidecorner mechanism
Mécánisme Slidecorner pour colonne d'angle
Mecanismo slidecorner para columna ángulo
Slidecorner-Mechanismus für Eckschrank

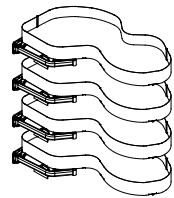

4 cesti estraibili con fondo
4 removable baskets with bottom
4 paniers amovibles avec fond
4 cestas extraíbles con fondo
4 Schubkasten mit Boden

	L/W	CODICE	PUNTI
dx	90	KMA0180CSIGD	1.162
sx	90	KMA0180CSIGS	1.162
dx	105	KMA0190CSIGD	1.223
sx	105	KMA0190CSIGS	1.223

Carrello dispensa per colonna H. 132 cm

Tall units pull out H 132 cm
Chariot de garde-manger pour colonne H 132 cm
Carrito dispensa para columna H 132 cm
Vorratswagen für Säule H 132 cm

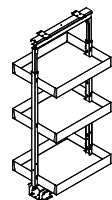

	L/W	CODICE	PUNTI
	30	KMD012412SIG	657
	45	KMD013912SIG	747

Carrello dispensa per colonna H. 195/210/225/240 cm

Tall units pull out H 195/210/225/240 cm
Chariot de garde-manger pour colonne H 195/210/225/240 cm
Carrito dispensa para columna H 195/210/225/240 cm
Apothekerschrank für Schrank 195/210/225/240 cm

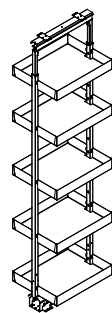

	L/W	CODICE	PUNTI
	30	KMD012419SIG	833
	45	KMD013919SIG	970

Basi con maniglia
Base units with handle

Basi con gola
Base units with groove

Colonne
Tall units

Pensili
Wall units

Elementi speciali
Special elements

Maniglie gole zoccoli
Handles grooves plinth

Illuminazione
Lighting

Accessori
Accessories

Componenti e meccanismi
Components e mechanism

MECCANISMI SIGE

Sige Mechanisms
Mécanismes Sige
Mecanismos Sige
Sige Mechanismen

Meccanismo tandem per colonna H. 195/210/225/240 cm

Tandem mechanism for tall units H 195/210/225/240 cm
Mécanisme tandem pour colonne H 195/210/225/240 cm
Mecanismo tándem para columna H 195/210/225/240 cm
Tandemmechanismus für Schrank H 195/210/225/240 cm

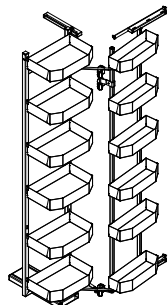

L/W	CODICE	PUNTI
45	KME013918SIG	1.209
60	KME015418SIG	1.334

Meccanismo estraibile per colonna H. 195/210/225/240 cm

Pull-out mechanism for tall units H 195/210/225/240 cm
Mécanisme extractible pour colonne H 195/210/225/240 cm
Mecanismo de extracción para columna H 195/210/225/240 cm
Ausziehvorrichtung für Schrank H 195/210/225/240 cm

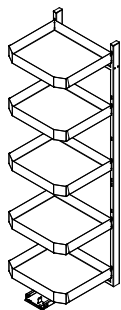

L/W	CODICE	PUNTI
60	KMT015419SIG	2.361

MECCANISMI KESSEBHOME

Kessebhome mechanisms
Mécánismes de Kessebhome
Mecanismos Kessebhome
Kessebhome-Mechanismen

Carrello estraibile per base L. 15 cm

Base unit pull-out W 15 cm
Chariot coulissant pour L 15 cm bases
Carrito extraíble para base L 15 cm
Apothekerschrank für B 15 cm Unterschrank

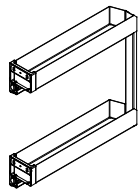

Ad estrazione totale e chiusura soft
Full extraction and soft close
Extraction totale et fermeture amortie
Extracción total y cierre suave
Vollauszug und Soft Close

	CODICE	PUNTI
antracite	KMC0108KES	169

Carrello estraibile per base L. 30 cm

Base unit pull-out W 30 cm
Chariot coulissant pour base L 30 cm
Carrito extraíble para base de L 30 cm
Apothekerschrank für L 30 cm Unterschrank

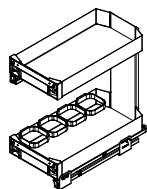

Ad estrazione totale e chiusura soft
Full extraction and soft close
Extraction totale et fermeture amortie
Extracción total y cierre suave
Vollauszug und Soft Close

	CODICE	PUNTI
antracite	KMC0224KES	223

Meccanismo slidecorner per base angolo

Slidecorner mechanism for corner base unit
Mécánisme Slidecorner pour base d'angle
Mecanismo slidecorner para base ángulo
Slidecorner-Mechanismus für Eckunterschrank

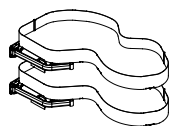

2 cesti estraibili con fondo
2 removable baskets with bottom
2 paniers extractibles avec fond
2 cestas extraíbles con fondo
2 Schubkasten mit Boden

	L/W	CODICE	PUNTI
dx	90	KMA0180BKESD	865
sx	90	KMA0180BKESS	865
dx	105	KMA0190BKESD	968
sx	105	KMA0190BKESS	968

Basi con maniglia
Base units with handle

Basi con gola
Base units with groove

Colonne
Tall units

Pensili
Wall units

Elementi speciali
Special elements

Maniglie gole zoccoli
Handles grooves plinth

Illuminazione
Lighting

Accessori
Accessories

Componenti e meccanismi
Components e mechanism

MECCANISMI KESSEBHOME

Kessebhome mechanisms
Mécánismes de Kessebhome
Mecanismos Kessebhome
Kessebhome-Mechanismen

Meccanismo slidecorner per colonna angolo

Corner tall units slidecorner mechanism
Mécánisme Slidecorner pour colonne d'angle
Mecanismo slidecorner para columna ángulo
Slidecorner-Mechanismus für Eckschrank

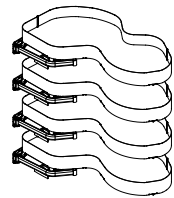

4 cesti estraibili con fondo
4 removable baskets with bottom
4 paniers amovibles avec fond
4 cestas extraíbles con fondo
4 Schubkasten mit Boden

	L/W	CODICE	PUNTI
dx	90	KMA0180CKESD	1.729
sx	90	KMA0180CKESS	1.729
dx	105	KMA0190CKESD	1.936
sx	105	KMA0190CKESS	1.936

Carrello dispensa per colonna H. 132 cm

Tall units pull out H 132 cm
Chariot de garde-manger pour colonne H 132 cm
Carrito dispensa para columna H 132 cm
Vorratswagen für Säule H 132 cm

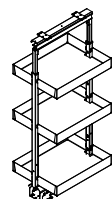

	L/W	CODICE	PUNTI
	30	KMD012412KES	803
	45	KMD013912KES	926

Carrello dispensa per colonna H. 195/210/225/240 cm

Tall units pull out H 195/210/225/240 cm
Chariot de garde-manger pour colonne H 195/210/225/240 cm
Carrito dispensa para columna H 195/210/225/240 cm
Apothekerschrank für Schrank 195/210/225/240 cm

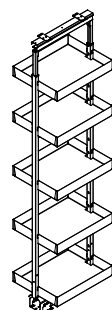

	L/W	CODICE	PUNTI
	30	KMD012419KES	975
	45	KMD013919KES	1.171

MECCANISMI KESSEMBHOMER

Kessembhomer mechanisms
 Mécanismes de Kessembhomer
 Mecanismos Kessembhomer
 Kessembhomer-Mechanismen

Meccanismo tandem per colonna H. 195/210/225/240 cm

Tandem mechanism for tall units H 195/210/225/240 cm
 Mécanisme tandem pour colonne H 195/210/225/240 cm
 Mecanismo tandem para columna H 195/210/225/240 cm
 Tandemmechanismus für Schrank H 195/210/225/240 cm

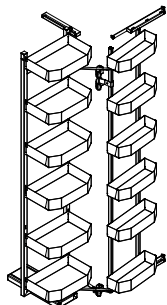

L/W	CODICE	PUNTI
45	KME013918KES	1.877
60	KME015418KES	1.948

Meccanismo estraibile per colonna H. 195/210/225/240 cm

Pull-out mechanism for tall units H 195/210/225/240 cm
 Mécanisme extractible pour colonne H 195/210/225/240 cm
 Mecanismo de extracción para columna H 195/210/225/240 cm
 Ausziehvorrichtung für Schrank H 195/210/225/240 cm

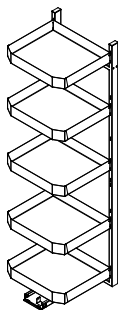

L/W	CODICE	PUNTI
60	KMT015419KES	2.139

Basi con maniglia
 Base units with handle

Basi con gola
 Base units with groove

Colonne
 Tall units

Pensili
 Wall units

Elementi speciali
 Special elements

Maniglie gole zoccoli
 Handles grooves plinth

Illuminazione
 Lighting

Accessori
 Accessories

Componenti e meccanismi
 Components e mechanism

PIEDINI

Feet
Pieds
Patas
Füße

Piedini PVC con base tonda per basi L.15/25

PVC feet with round base for W. 15/25 base units
Pieds en PVC avec base ronde pour bases L. 15/25
Patas en PVC con base redonda para bases L. 15/25
PVC-Füße mit rundem Sockel für L. 15/25 Sockel

Confezione 4 piedini
Pack of 4 feet
Set 4 pieds
Juego de 4 patas
Packung mit 4 Füßen

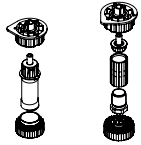

H/H	CODICE	PUNTI
6	KPI0106	15
10	KPI0206	17

Piedini PVC con base triangolare per basi o colonne L. 30-120

PVC feet with triangular base for W. 30/120 base units or tall units
Pieds en PVC avec base triangulaire pour bases ou colonnes L. 30/120
Patas en PVC con base triangular para bases o columnas L. 30/120
PVC-Füße mit dreieckiger Basis für L. 30/120 Unterschränke oder Hochschränke

Confezione 4 piedini
Pack of 4 feet
Set 4 pieds
Juego de 4 patas
Packung mit 4 Füßen

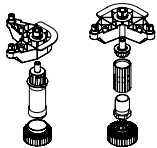

H/H	CODICE	PUNTI
6	KPI0110	10
10	KPI0210	12

CONDIZIONI GENERALI DI VENDITA

CONDIZIONI GENERALI

La fornitura si intende ai punti indicati nel listino ed alle condizioni generali di vendita in vigore, che si intendono conosciute ed accettate dal Cliente. I prezzi indicati nel listino, espressi in punti, sono al netto di iva, installazione e/o qualsiasi prestazione ulteriore. Gli eventuali lavori "fuori misura", se non già regolamentati nel listino, qualora approvati da DA group s.r.l. verranno quotati e valorizzati caso per caso. Le proposte d'ordine si intendono accettate "salvo approvazione della casa", che DA group s.r.l. si riserva di dare a proprio esclusivo ed insindacabile giudizio.

TERMINI DI CONSEGNA

I termini di consegna comunicati al Cliente non possono considerarsi vincolanti in quanto sono subordinati ai tempi di produzione e/o alla disponibilità della merce a magazzino. Qualora per causa di forza maggiore venga previsto un ritardo rispetto ai termini di consegna comunicati verrà concordato tra le parti un nuovo termine. Viene escluso sin d'ora che i ritardi possano dare diritto a qualsiasi risarcimento danni, diretto o indiretto, o annullamento dell'ordine.

SPEDIZIONI

La merce viaggia a rischio e pericolo del Cliente quando venduta franco fabbrica. In caso di consegna richiesta in un luogo diverso dal punto di vendita o magazzino dell'acquirente, sarà applicato un supplemento di prezzo, quantificato caso per caso. Resta inteso che la merce viene sempre consegnata "sponda camion". Il Cliente è tenuto ad ispezionare accuratamente la merce ricevuta ed eventuali reclami riguardanti danni subiti durante il trasporto dovranno essere immediatamente segnalati al vettore ed annotati sul documento di trasporto; reclami riguardanti la qualità della merce e/o eventuali difetti di fabbricazione e/o difformità rispetto all'ordine dovranno pervenire entro e non oltre otto giorni dalla consegna a DA group s.r.l. a mezzo raccomandata a.r.

Trascorso tale periodo DA group s.r.l. declina qualsiasi propria responsabilità. In relazione ai reclami rivolti nei modi e nei tempi sopra descritti si precisa, comunque, che non si accetteranno resi di merce se non debitamente autorizzati da DA group s.r.l. | Per consegne in Italia di ordini con importi inferiori a 500 punti viene applicato un contributo forfettario pari a 50 punti. Per consegne fuori dall'Italia di ordini con importi inferiori a 750 punti viene applicato un contributo forfettario pari a 75 punti.

SOSTITUZIONI E RESI

La merce, qualora sostituita, dovrà essere immediatamente resa disponibile correttamente imballata dal Cliente, all'atto della sostituzione stessa. Qualora, per qualsiasi motivo, la merce sostituita non fosse resa disponibile, DA group s.r.l. si riserva trascorsi 30 giorni dalla sostituzione, il diritto di esigerne il pagamento. I resi accettati saranno valutati al prezzo pagato dal Cliente e, se non in buono stato di conservazione, al valore riconosciuto ad insindacabile giudizio dell'ufficio tecnico DA group s.r.l. Si precisa che anche nel caso di reclami effettuati entro i termini i pagamenti non potranno essere sospesi. Per le lavorazioni eseguite "fuori misura" e/o personalizzate su richiesta del Cliente non si accettano né resi né richieste di sostituzione.

DA group s.r.l. garantisce i propri prodotti da difetti occulti e per l'utilizzo cui il bene è destinato; i danni derivanti da incuria, negligenza e/o uso improprio non daranno diritto a reclami e/o richieste di danni, diretti o indiretti. Qualsiasi controversia che non fosse possibile risolvere in via bonaria tra le parti sarà devoluta all'unico Foro competente di Pordenone.

PAGAMENTI

Le modalità di pagamento ed i relativi termini sono quelli concordati previamente con DA group s.r.l. e così come risultanti nella relativa "scheda anagrafica". Sono ritenuti validi solo i pagamenti effettuati direttamente a DA group s.r.l. e/o a propri incaricati e/o propri agenti autorizzati. I titoli di credito eventualmente accettati lo sono sempre "salvo buon fine". Il ritardo nei pagamenti, anche di una sola rata, dà diritto a DA group s.r.l. di richiedere l'integrale pagamento del prezzo di vendita con l'aggravio degli interessi legali ed eventuali spese. La merce rimane di proprietà DA group s.r.l. fino all'avvenuto integrale pagamento del prezzo di vendita. Eventuali insolvenze o ritardi nei pagamenti in scadenza da parte del Cliente relativamente a forniture già effettuate, daranno facoltà a DA group s.r.l. di sospendere o annullare l'esecuzione degli ordini in corso anche se già accettati.

MODIFICHE AI PRODOTTI

In riferimento al continuo miglioramento tecnologico del prodotto, DA group s.r.l. si riserva il diritto di apportare le modifiche ritenute più opportune alla modellistica, che non abbiano ad incidere negativamente sulla qualità e sull'estetica del prodotto stesso e ciò a proprio insindacabile giudizio e senza la necessità di un preavviso. I colori delle parti verniciate e delle essenze sono indicativi in quanto non è tecnicamente possibile mantenere le stesse tonalità di colore nel tempo; si declina, pertanto, ogni responsabilità per richieste di accoppiamento pervenute in tempi diversi anche se DA group s.r.l. si adopererà a fornire la migliore soluzione tecnica possibile. È facoltà di DA group s.r.l. di apportare, a proprio insindacabile giudizio, in qualsiasi momento e senza preavviso, tutte le variazioni che riterrà necessarie, alle caratteristiche tecniche, costruttive, estetiche dei propri modelli, nonché ai prezzi indicati nel presente listino. I cataloghi e dépliant in circolazione hanno valore puramente illustrativo, eventuali inesattezze di stampa e/o di descrizione delle caratteristiche e/o indicazioni di misure non sostanziali dei prodotti non potranno dar luogo a responsabilità in capo a DA group s.r.l.

DIRITTO DI PROPRIETÀ

È vietata la pubblicità, con foto o con altri mezzi, della merce fornita senza la preventiva autorizzazione scritta di DA group s.r.l.

UTILIZZO DEL MARCHIO

È fatto divieto assoluto a tutti i clienti, salvo patto contrario, l'utilizzo del marchio "Comprex". In caso di accertata violazione DA group s.r.l. si riserva il diritto di agire giudizialmente per ottenere il riconoscimento dei danni.

Basi con maniglia
Base units with handle

Basi con gola
Base units with groove

Colonne
Tall units

Penzili
Wall units

Elementi speciali
Special elements

Maniglie gole zoccoli
Handles grooves plinth

Illuminazione
Lighting

Accessori
Accessories

Componenti e meccanismi
Components e mechanism

GENERAL SALES CONDITIONS

GENERAL TERMS AND CONDITIONS

The supply is understood to be at the points indicated in the price list and at the general conditions of sale in force, which are understood to be known and accepted by the Customer. The prices indicated in the price list, expressed in points, are exclusive of vat, installation and/or any additional services. Any "oversized" work, if not already regulated in the price list, if approved by DA group s.r.l. will be quoted and valued on a case-by-case basis. Order proposals are considered accepted "unless approved by the house," which DA group s.r.l. reserves the right to give at its sole and unquestionable judgment.

DELIVERY TERMS

The delivery dates notified to the Customer shall not be considered as binding, since they are subject to the production leadime and/or availability of the stocks in the warehouse. In case of force majeure, if a delay is expected in relation to the notified delivery date, a new deadline will be agreed between parties. It is hereby specified that such delay shall not entitle the Customer to any damage compensation, direct or consequential, nor to the cancellation of the order.

SHIPPING

Goods travel at the customer's risk when sold ex works. In the event of requested delivery to a place other than the buyer's point of sale or warehouse, a price surcharge will be applied, quantified on a case-by-case basis. It is understood that the goods are always delivered "tailgate". The customer is required to carefully inspect the goods received and any complaints regarding damage incurred during transport must be immediately reported to the carrier and noted on the transport document; complaints regarding the quality of the goods and / or any manufacturing defects and / or deviations from the order must be received no later than eight days after delivery to DA group s.r.l. by registered mail.

After this period DA group s.r.l. disclaims any liability. In relation to complaints made in the manner and within the time described above it is specified, however, that returns of goods will not be accepted unless duly authorized by DA group s.r.l.. A flat fee of 50 points is charged for deliveries within Italy of orders with amounts less than 500 points. A flat-rate contribution of 75 points is charged for deliveries outside Italy of orders with amounts less than 750 points.

REPLACEMENTS AND RETURNS

The goods, if replaced, shall be immediately made available correctly packaged by the Customer at the time of replacement. If, for any reason, the replaced goods are not made available, DA group s.r.l. reserves the right, after 30 days from the replacement, to demand payment. Accepted returns will be valued at the price paid by the customer and, if not in good condition, at the value recognized at the sole discretion of the DA group s.r.l. technical department. It should be noted that even in the case of claims made within the terms, payments may not be suspended. For work carried out "out of size" and/or customised at the request of the customer, neither returns nor requests for replacement will be accepted.

DA group s.r.l. guarantees its products from hidden defects and for the use for which the goods are intended; damages resulting from carelessness, negligence and / or improper use will not give right to complaints and / or claims for damages, direct or indirect. Any dispute that cannot be settled amicably between the parties shall be devolved to the sole competent Court of Pordenone.

PAYMENTS

Payment methods and relative terms shall be agreed beforehand with DA group s.r.l., in accordance to the personal data sheet. Only the payments made directly to DA group s.r.l. and/or its representatives and/or its authorized agents are considered as valid ones. Any credit instrument accepted is subject to clearance. Any delay in payments, even of a single instalment, entitles DA group s.r.l. to demand the full settlement of the sales price with the additional increase of legal costs and eventual extra charges. The goods remain full property of DA group s.r.l. until receipt of the entire payment of the sales price. Any insolvency or delays in the payments with reference to supplies already executed shall grant DA group s.r.l. the power to suspend or cancel the execution of the orders in progress, even if already accepted.

PRODUCT MODIFICATIONS

With reference to the continuous technological improvement of the product, DA group s.r.l. reserves the right to make any changes deemed appropriate to the modeling, which do not have a negative impact on the quality and aesthetics of the product itself and this at its sole discretion and without the need for prior notice. The colours of the painted parts and essences are indicative as it is not technically possible to maintain the same colour tones over time; therefore, DA group s.r.l. declines all responsibility for matching requests received at different times even if DA group s.r.l. will endeavour to provide the best possible technical solution. It is the right of DA group s.r.l. to make, at its sole discretion, at any time and without notice, all the changes it deems necessary, to the technical, constructional, aesthetic characteristics of its models, as well as to the prices indicated in this price list. The catalogues and brochures in circulation have a purely illustrative value, any inaccuracies in the printing and/or description of the characteristics and/or indications of non-substantial measurements of the products shall not give rise to liability on the part of DA group s.r.l.

RIGHT OF OWNERSHIP

Any advertisement of the supplied furniture, by means of pictures or any other way, is forbidden without a previous written authorization by DA group s.r.l.

TRADEMARK USE

It is absolutely forbidden for all customers, unless otherwise agreed, to use the trademark "Complex". In the event of an ascertained violation DA group s.r.l. reserves the right to take legal action for damages.

CONDITIONS GÉNÉRALES DE VENTE

CONDITIONS GÉNÉRALES D'UTILISATION

La fourniture s'entend aux points indiqués dans le tarif et aux conditions générales de vente en vigueur, qui sont réputées connues et acceptées par le Client. Les prix indiqués dans le tarif, exprimés en points, sont nets de TVA, d'installation et/ou d'éventuels services supplémentaires. Tout travail "surdimensionné", s'il n'est pas déjà réglé dans le tarif, s'il est approuvé par DA group s.r.l., fera l'objet d'un devis et d'une évaluation au cas par cas. Les propositions de commande seront considérées comme acceptées "sous réserve de l'approbation de la maison", que le groupe DA s.r.l. se réserve le droit de donner à sa seule et incontestable appréciation.

CONDITIONS DE LIVRAISON

Les dates de livraison indiquées au client ne doivent pas être considérées comme étant définitives car elles dépendent des délais de production et/ou de la disponibilité des produits en stock. Si à cause d'une force majeure un retard est attendu par rapport à la date de livraison prévue, une nouvelle date de livraison sera convenue entre les deux parties. Il est ici précisé que tout retard de cet ordre ne donne droit de la part du client à aucun dédommagement, direct ou indirect ni aucune annulation de la commande.

EXPÉDITION

Les marchandises voyagent aux risques et périls du client lorsqu'elles sont vendues départ usine. En cas de demande de livraison à un endroit autre que le point de vente ou l'entrepôt de l'acheteur, un supplément de prix sera appliqué, quantifié au cas par cas. Il est entendu que les marchandises sont toujours livrées "hayon". Le client est tenu d'inspecter soigneusement les marchandises reçues et toute réclamation concernant des dommages survenus pendant le transport doit être immédiatement signalée au transporteur et notée sur le document de transport ; les réclamations concernant la qualité des marchandises et/ou d'éventuels défauts de fabrication et/ou des déviations par rapport à la commande doivent être reçues au plus tard huit jours après la livraison à DA group s.r.l. par courrier recommandé.

Passé ce délai, DA group s.r.l. décline toute responsabilité. En ce qui concerne les réclamations faites de la manière et dans les délais décrits ci-dessus, il est toutefois précisé que les retours de marchandises ne seront pas acceptés, à moins qu'ils n'aient été dûment autorisés par le groupe DA s.r.l.. Pour les livraisons en Italie de commandes inférieures à 500 points, une contribution forfaitaire de 50 points est prélevée. Pour les livraisons hors d'Italie de commandes inférieures à 750 points, une contribution forfaitaire de 75 points est facturée.

REPLACEMENTS ET RETOURS

Les marchandises, si elles sont remplacées, doivent être mises à disposition immédiatement et correctement emballées par le client au moment du remplacement. Si, pour quelque raison que ce soit, la marchandise remplacée n'est pas mise à disposition, DA group s.r.l. se réserve le droit, après 30 jours à compter du remplacement, d'exiger le paiement. Les retours acceptés seront évalués au prix payé par le client et, s'ils ne sont pas en bon état, à la valeur reconnue à la seule discrétion du service technique de DA group s.r.l.. Il est à noter que même en cas de réclamation effectuée dans les délais, les paiements ne peuvent être suspendus. Pour les travaux réalisés "hors gabarit" et/ou personnalisés à la demande du client, aucun retour ni aucune demande de remplacement ne seront acceptés.

DA group s.r.l. garantit ses produits contre les vices cachés et pour l'usage auquel la marchandise est destinée ; les dommages résultant de l'imprudence, de la négligence et/ou d'un usage impropre ne donneront pas droit à des réclamations et/ou à des demandes de dommages-intérêts, directs ou indirects. Tout litige qui ne peut être réglé à l'amiable entre les parties sera dévolu au seul Tribunal compétent de Pordenone.

PAIEMENTS

Les méthodes de paiement et les termes qui y sont relatifs sont ceux préalablement convenus avec DA group s.r.l. et tels qu'ils sont reportés dans le "fichier d'informations personnelles" respectif. Seuls les paiements effectués directement auprès de DA group s.r.l. et/ou de ses représentants et/ou de ses agents autorisés sont considérés comme valables. Toute forme de crédit accepté n'est que "sous condition de paiement final". Tout retard dans les paiements, même d'un seul versement, donne à DA group s.r.l. le droit de réclamer le paiement total du prix de la vente avec une augmentation due aux intérêts légaux et à toute autre dépense. La marchandise reste la propriété de DA group s.r.l. jusqu'à réception du paiement entier du prix de la vente. Toute insolvabilité ou retard de paiement dû par le client relatif à des fournitures déjà livrées donnera à DA group s.r.l. la faculté de suspendre ou d'annuler l'exécution des commandes en cours, même si elles sont déjà acceptées.

MODIFICATIONS DU PRODUIT

Dans le cadre de l'amélioration technologique continue du produit, DA group s.r.l. se réserve le droit d'apporter toutes les modifications jugées opportunes à la modélisation, qui n'ont pas d'impact négatif sur la qualité et l'esthétique du produit lui-même, et ce à sa seule discrétion et sans nécessité d'avis préalable. Les couleurs des parties peintes et des essences sont indicatives car il n'est pas techniquement possible de maintenir les mêmes tons de couleur dans le temps ; par conséquent, DA group s.r.l. décline toute responsabilité pour les demandes de correspondance reçues à des moments différents, même si DA group s.r.l. s'efforcera de fournir la meilleure solution technique possible. DA group s.r.l. a le droit d'apporter, à sa seule discrétion, à tout moment et sans préavis, toutes les modifications qu'elle juge nécessaires aux caractéristiques techniques, constructives et esthétiques de ses modèles, ainsi qu'aux prix indiqués dans la présente liste de prix. Les catalogues et brochures en circulation ont une valeur purement illustrative, les éventuelles inexactitudes dans l'impression et/ou la description des caractéristiques et/ou les indications de mesures non substantielles des produits ne sauraient engager la responsabilité de DA group s.r.l..

DROIT DE PROPRIÉTÉ

Il est interdit de faire de la publicité, avec des photos ou par d'autres moyens, à la marchandises fournies sans l'autorisation écrite préalable de DA group s.r.l.

UTILISATION DES MARQUES

Il est absolument interdit à tous les clients, sauf accord contraire, d'utiliser la marque "Complex". En cas de violation constatée, DA group s.r.l. se réserve le droit d'intenter une action en dommages et intérêts.

Basi con maniglia
Base units with handle

Basi con gola
Base units with groove

Colonne
Tall units

Pensili
Wall units

Elementi speciali
Special elements

Maniglie gole zoccoli
Handles grooves plinth

Illuminazione
Lighting

Accessori
Accessories

Componenti e meccanismi
Components e mechanism

CONDICIONES GENERALES DE VENTA

CONDICIONES GENERALES

El suministro se entiende realizado en los puntos indicados en la lista de precios y en las condiciones generales de venta vigentes, que se entienden conocidas y aceptadas por el Cliente. Los precios indicados en la lista de precios, expresados en puntos, son netos de IVA, instalación y/o eventuales prestaciones adicionales. Cualquier trabajo "sobredimensionado", si no está ya regulado en la lista de precios, si es aprobado por DA group s.r.l. se cotizará y valorará caso por caso. Las propuestas de pedido se considerarán aceptadas "previa aprobación de la casa", que DA group s.r.l. se reserva el derecho de otorgar a su exclusivo e incuestionable juicio.

CONDICIONES DE ENTREGA

Las fechas de entrega notifi cadas al Cliente no deben ser consideradas vinculantes, ya que están sujetas a la duración de fabricación y/o disponibilidad de los productos en el almacén. Si, por causas de fuerza mayor, se espera un retraso respecto a la fecha de entrega notificada, las partes acordarán una nueva fecha de entrega. Por la presente se establece que dicho retraso no dará derecho al Cliente a exigir ningún tipo de indemnización, directa o consecencial, o a cancelar el pedido

ENVÍO

Las mercancías viajan por cuenta y riesgo del cliente cuando se venden franco fábrica. En caso de solicitarse la entrega en un lugar distinto al punto de venta o almacén del comprador, se aplicará un recargo en el precio, cuantificado caso por caso. Se entiende que la mercancía se entrega siempre "a puerta trasera". El cliente está obligado a inspeccionar atentamente la mercancía recibida y cualquier reclamación relativa a los daños sufridos durante el transporte debe ser comunicada inmediatamente al transportista y anotada en el documento de transporte; las reclamaciones relativas a la calidad de la mercancía y/o a eventuales defectos de fabricación y/o desviaciones del pedido deben ser recibidas a más tardar ocho días después de la entrega a DA group s.r.l. por correo certificado.

Transcurrido este plazo, DA group s.r.l. declina toda responsabilidad. En relación con las reclamaciones efectuadas en la forma y dentro del plazo anteriormente descritos se especifica, no obstante, que no se aceptarán devoluciones de mercancías que no hayan sido debidamente autorizadas por DA group s.r.l. | Para las entregas dentro de Italia de pedidos inferiores a 500 puntos, se cobrará una contribución a tanto alzado de 50 puntos. Para las entregas fuera de Italia de pedidos inferiores a 750 puntos, se cobrará una contribución a tanto alzado de 75 puntos.

SUSTITUCIONES Y DEVOLUCIONES

La mercancía, en caso de sustitución, deberá ser puesta inmediatamente a disposición del Cliente correctamente embalada en el momento de la sustitución. Si, por cualquier motivo, la mercancía sustituida no se pusiera a disposición, DA group s.r.l. se reserva el derecho, transcurridos 30 días desde la sustitución, de exigir el pago. Las devoluciones aceptadas se valorarán al precio pagado por el cliente y, si no están en buen estado, al valor reconocido a criterio exclusivo del departamento técnico de DA group s.r.l..

Cabe señalar que, incluso en el caso de reclamaciones efectuadas dentro de los plazos, los pagos no podrán suspenderse. Para los trabajos realizados "fuera de medida" y/o personalizados a petición del cliente, no se aceptarán ni devoluciones ni solicitudes de sustitución.

DA group s.r.l. garantiza sus productos de vicios ocultos y para el uso al que están destinados los bienes; los daños resultantes de descuido, negligencia y/o uso inadecuado no darán derecho a reclamaciones y/o solicitudes de indemnización por daños y perjuicios, directos o indirectos. Cualquier controversia que no pueda resolverse amistosamente entre las partes se remitirá al único Tribunal competente de Pordenone.

PAGOS

Las formas de pago y los términos relativos son los acordados de antemano por DA group s.r.l. e indicados en la correspondiente "ficha de cliente".

Sólo los pagos realizados directamente a DA group s.r.l. y/o sus representantes y/o agentes autorizados se considerarán válidos. Todos los instrumentos de crédito aceptados se aceptarán "salvo reservas del caso". Cualquier retraso en los pagos, incluso de un solo plazo, otorga a DA group s.r.l. el derecho a exigir el pago completo del precio de venta incrementado de los intereses legales y cualquier otro gasto. Los artículos seguirán siendo de propiedad de DA group s.r.l. hasta el pago del precio de venta completo. Cualquier insolvencia o retraso en los pagos de pedidos ya entregados por parte del cliente otorga a DA group s.r.l. la facultad para suspender o cancelar la ejecución de los pedidos en progreso, incluso si ya han sido aceptados.

MODIFICACIONES DE PRODUCTOS

En referencia a la continua mejora tecnológica del producto, DA group s.r.l. se reserva el derecho de aportar las modificaciones que considere oportunas al modelado, que no tengan un impacto negativo sobre la calidad y la estética del producto mismo y esto a su sola discreción y sin necesidad de preaviso. Los colores de las partes pintadas y de las esencias son indicativos, ya que técnicamente no es posible mantener los mismos tonos de color a lo largo del tiempo; por lo tanto, DA group s.r.l. declina toda responsabilidad por las solicitudes de igualación recibidas en momentos diferentes, aunque DA group s.r.l. se esforzará por ofrecer la mejor solución técnica posible. DA group s.r.l. se reserva el derecho de aportar, a su entera discreción, en cualquier momento y sin previo aviso, todas las modificaciones que considere necesarias a las características técnicas, constructivas y estéticas de sus modelos, así como a los precios indicados en la presente tarifa. Los catálogos y folletos en circulación tienen un valor puramente ilustrativo, cualquier inexactitud en la impresión y/o descripción de las características y/o indicaciones de medidas no sustanciales de los productos no dará lugar a responsabilidad por parte de DA group s.r.l.

DERECHO DE PROPIEDAD

Está prohibida la publicidad, con fotos u otros medios, de los bienes suministrados sin la previa autorización escrita por parte de DA group s.r.l.

USO DE LA MARCA

Está absolutamente prohibido a todos los clientes, salvo acuerdo en contrario, utilizar la marca "Complex". En caso de infracción demostrada, DA group s.r.l. se reserva el derecho de emprender acciones legales por daños y perjuicios.

ALLGEMEINE VERKAUFSBEDINGUNGEN

ALLGEMEINE BEDINGUNGEN UND KONDITIONEN

Die Lieferung erfolgt zu den in der Preisliste angegebenen Preisen und zu den geltenden allgemeinen Verkaufsbedingungen, die als bekannt und vom Kunden akzeptiert gelten. Die in der Preisliste angegebenen Preise, die in Punkten ausgedrückt sind, verstehen sich ohne Mehrwertsteuer, Installation und/oder zusätzliche Dienstleistungen. Alle "überdimensionierten" Arbeiten, die nicht bereits in der Preisliste geregelt sind, werden, wenn sie von DA group s.r.l. genehmigt wurden, von Fall zu Fall angeboten und bewertet. Bestellvorschläge gelten als angenommen "vorbehaltlich der Genehmigung durch das Haus", die sich DA group s.r.l. nach eigenem und unanfechtbarem Ermessen vorbehält.

LIEFERBEDINGUNGEN

Die dem Kunden mitgeteilten Liefertermine sind unverbindlich, da sie an die Produktion und/oder an die Verfügbarkeit der Ware im Lager gebunden sind. Wenn die mitgeteilten Liefertermine durch höhere Gewalt überschritten werden, wird mit dem Kunden ein neuer Termin vereinbart. Von vornherein ist ausgeschlossen, dass Verspätungen einen direkten oder indirekten Schadensersatz oder Auftragsstornierung berechtigen.

VERSAND

Die Waren reisen auf Risiko des Kunden, wenn sie ab Werk verkauft werden. Bei gewünschter Lieferung an einen anderen Ort als die Verkaufsstelle oder das Lager des Käufers wird ein Preisaufschlag erhoben, der von Fall zu Fall festgelegt wird. Es wird davon ausgegangen, dass die Ware immer "heckwärts" geliefert wird. Der Kunde ist verpflichtet, die erhaltene Ware sorgfältig zu prüfen und eventuelle Beanstandungen bezüglich Transportschäden sofort dem Spediteur mitzuteilen und auf dem Transportdokument zu vermerken; Beanstandungen bezüglich der Qualität der Ware und / oder eventueller Herstellungsfehler und / oder Abweichungen von der Bestellung müssen spätestens acht Tage nach der Lieferung per Einschreiben bei DA group s.r.l. eingehen.

Nach Ablauf dieser Frist lehnt die DA group s.r.l. jede Haftung ab. In Bezug auf Reklamationen, die auf die oben beschriebene Art und Weise und innerhalb der oben genannten Frist vorgebracht werden, wird jedoch darauf hingewiesen, dass Warenrücksendungen nicht akzeptiert werden, es sei denn, sie wurden von der DA group s.r.l. ordnungsgemäß genehmigt. | Für Lieferungen innerhalb Italiens bei Bestellungen unter 500 Punkten wird ein Pauschalbeitrag von 50 Punkten erhoben. Für Lieferungen außerhalb Italiens von Bestellungen unter 750 Punkten wird ein Pauschalbeitrag von 75 Punkten erhoben.

ERSETZUNGEN UND RÜCKGABEN

Die ersetzte Ware muss vom Kunden zum Zeitpunkt des Austauschs unverzüglich und ordnungsgemäß verpackt zur Verfügung gestellt werden. Sollte die ersetzte Ware aus irgendeinem Grund nicht zur Verfügung gestellt werden, behält sich DA group s.r.l. das Recht vor, nach Ablauf von 30 Tagen nach dem Austausch die Zahlung zu verlangen. Angenommene Rücksendungen werden zu dem vom Kunden gezahlten Preis und, wenn sie nicht in gutem Zustand sind, zu dem nach alleinigem Ermessen der technischen Abteilung von DA group s.r.l. anerkannten Wert bewertet. Es wird darauf hingewiesen, dass auch bei fristgerechten Reklamationen die Zahlungen nicht ausgesetzt werden können. Für Arbeiten, die auf Wunsch des Kunden "nach Maß" und/oder individuell angefertigt wurden, werden weder Rücksendungen noch Anträge auf Ersatz angenommen. DA group s.r.l. garantiert, dass ihre Produkte keine versteckten Mängel aufweisen und für den vorgesehenen Verwendungszweck geeignet sind; Schäden, die auf Unachtsamkeit, Fahrlässigkeit und/oder unsachgemäßen Gebrauch zurückzuführen sind, berechtigen nicht zu direkten oder indirekten Reklamationen und/oder Schadensersatzansprüchen. Jede Streitigkeit, die nicht gütlich zwischen den Parteien beigelegt werden kann, wird an das einzige zuständige Gericht von Pordenone übertragen werden.

ZAHLUNGEN

Die Zahlungsarten und die betreffenden Fälligkeiten werden vorab mit DA group s.r.l. vereinbart und sind auf der jeweiligen "Kundenkarte" eingetragen. Gültig sind nur Zahlungen, die direkt an DA group s.r.l. und/oder an ihre Beauftragten und/oder an berechnigte Vertreter geleistet werden. Eventuelle Wechsel werden immer unter "vorausgesetzter pünktlicher Begleichung" akzeptiert. Die verspätete Zahlung auch nur einer Rate, berechtigt Dall'Agnese s.p.a. die vollständige Zahlung des Verkaufspreises mit Belastung der gesetzlichen Zinsen und eventueller Auslagen zu fordern. Bis zur vollständigen Zahlung des Verkaufspreises bleibt die Ware Eigentum der Firma DA group s.r.l. Zahlungsunfähigkeit des Kunden und verspätete Zahlung der Fälligkeiten für bereits erfolgte Lieferungen, berechtigen DA group s.r.l. die Ausführung der laufenden Bestellungen, auch wenn sie bereits angenommen sind, einzustellen.

PRODUKTÄNDERUNGEN

Im Hinblick auf die ständige technologische Verbesserung des Produkts behält sich die DA group s.r.l. das Recht vor, nach eigenem Ermessen und ohne vorherige Ankündigung Änderungen an der Modellierung vorzunehmen, die keine negativen Auswirkungen auf die Qualität und Ästhetik des Produkts selbst haben. Die Farben der lackierten Teile und der Essenzen sind indikativ, da es technisch nicht möglich ist, dieselben Farbtöne über die Zeit beizubehalten; daher lehnt die DA group s.r.l. jede Verantwortung für zu unterschiedlichen Zeitpunkten eingegangene Anpassungswünsche ab, auch wenn sich die DA group s.r.l. bemüht, die bestmögliche technische Lösung zu bieten. Die DA group s.r.l. behält sich das Recht vor, nach eigenem Ermessen, jederzeit und ohne Vorankündigung alle ihr notwendig erscheinenden Änderungen an den technischen, baulichen und ästhetischen Merkmalen ihrer Modelle sowie an den in dieser Preisliste angegebenen Preisen vorzunehmen. Die im Umlauf befindlichen Kataloge und Broschüren haben einen rein illustrativen Wert, eventuelle Ungenauigkeiten im Druck und/oder in der Beschreibung der Eigenschaften und/oder Angaben zu nicht wesentlichen Maßen der Produkte führen nicht zu einer Haftung seitens DA group s.r.l.

RECHT AUF EIGENTUM

Werbung mit Fotos oder anderen Mitteln für die gelieferten Waren ohne vorherige schriftliche Genehmigung von DA group s.r.l. ist verboten.

VERWENDUNG VON MARKENZEICHEN

Es ist allen Kunden, sofern nicht anders vereinbart, absolut untersagt, die Marke "Compres" zu verwenden. Im Falle einer erwiesenen Zuwiderhandlung behält sich die DA group s.r.l. das Recht vor, gerichtlich auf Schadensersatz zu klagen.

Basi con maniglia
Base units with handle

Basi con gola
Base units with groove

Colonne
Tall units

Pensili
Wall units

Elementi speciali
Special elements

Maniglie gole zoccoli
Handles grooves plinth

Illuminazione
Lighting

Accessori
Accessories

Componenti e meccanismi
Components e mechanism

DA group Srl

Via Mazzini, 3
33070 Maron di Brugnera (PN)
Italy

Reception: +39 0434 619111
Fax: +39 0434 624690
info@comprex.it

www.comprex.it



