

SOFA COLLECTION

PRICE LIST - FEBRUARY 2026

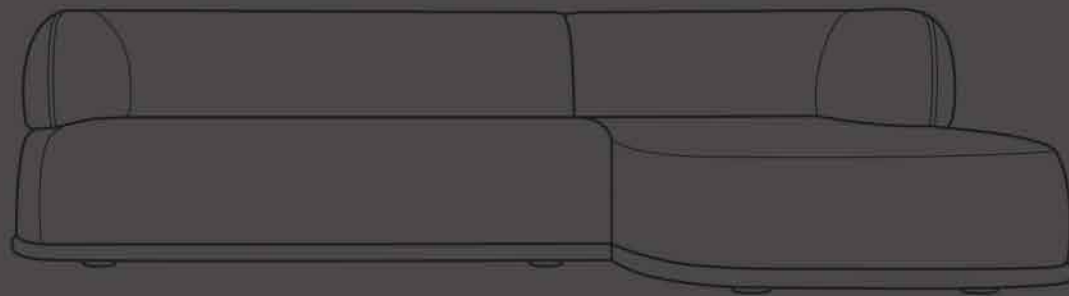

COEFFICIENTE D'ACQUISTO
PURCHASE COEFFICIENT

1,18

febbraio | february 2026

dallagnese

FINITURE FINISHES FINITIONS AUSFÜHRUNGEN ACABADOS	P. 2
DIVANI SOFAS CANAPÉS SOFA SOFÁS	P. 5
<ul style="list-style-type: none">• INEMURI• MILTON• PANAMA• POLDO• RAGGIO• SETTANTA• SUPERNOVA• SWING• TRAMA	<ul style="list-style-type: none">P. 6P. 14P. 23P. 27P. 38P. 46P. 53P. 61P. 69
POLTRONE ARMCHAIRS FAUTEUILS SESSEL SILLONES	P. 101
<ul style="list-style-type: none">• FLO• GULP LOUNGE• HULL LOUNGE• LE MANS LOUNGE• MADAME• MILTON• PANAMA• PLANKA• SUPERNOVA	<ul style="list-style-type: none">P. 102P. 104P. 106P. 108P. 110P. 112P. 114P. 116P. 118
POUF POUF POUF POUF POUF	P. 121
<ul style="list-style-type: none">• BESU• SUPERNOVA	<ul style="list-style-type: none">P. 122P. 123

COEFFICIENTE D'ACQUISTO
PURCHASE COEFFICIENT

1,18

febbraio | february 2026

LACCATI OPACHI E LUCIDI | MATT AND GLOSSY LACQUERS

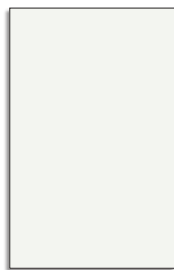

9003
Bianco
RAL 9003

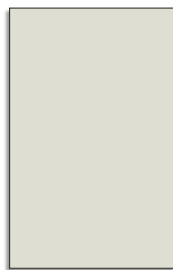

9002
Ghiaccio
RAL 9002

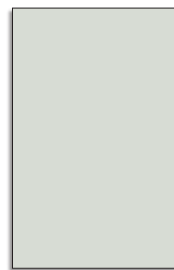

100
Sabbia
NCS S 1500-N

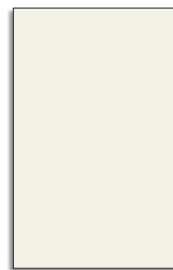

9010
Panna
RAL 9010

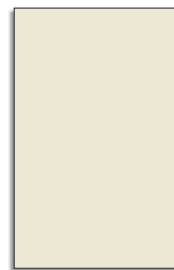

9001
Crema
RAL 9001



7044
Grigio seta
RAL 7044



68
Grigio perla
NCS S 1502-Y



71
Light grey
NCS S 2002-Y

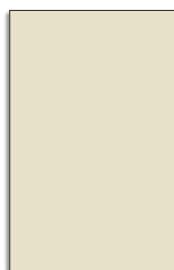

1013
Fior di loto
RAL 1013

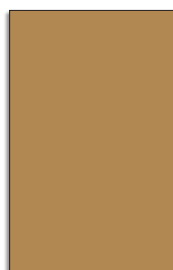

101
Giallo senape
NCS S 4040-Y10R



63
Tortora
NCS S 1502-Y50R



62
Canapa
NCS S 2005 Y50R



61
Corda
NCS S 3005 Y50R



72
Dark grey
RAL 7030



74
Terracotta
NCS S 5010-Y70R



73
Moka
NCS S 7010-Y70R



3005
Rosso bordeaux
RAL 3005



3003
Rosso
RAL 3003

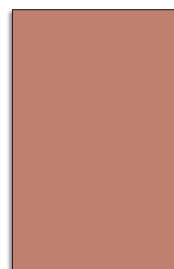

102
Rosa cipria
NCS S 3030-Y80R



173
Bruciato
NCS S 3050-Y50R



76
Carta da zucchero
NCS S 5005-B20G



7031
Grigio blu
RAL 7031



190
Verde pallido
NCS S 3020-G30Y



103
Verde malva
NCS S 5020-G70Y



7039
Grigio aston
RAL 7039

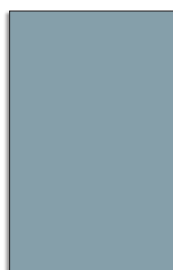

107
Celeste
NCS S 3020-B



104
Turchese
NCS S 6020-B50G



246
Grigio Garda
NCS S 3020-B60G



106
Blu cobalto
NCS S 7020-R90B



105
Oceano
NCS S 6030-B10G



7016
Grigio antracite
RAL 7016



9017
Nero
RAL 9017

La riproduzione dei colori su carta può risultare alterata rispetto agli originali, pertanto queste tinte sono da considerarsi indicative. | Laccato a campione/RAL con maggiorazione del 20% | Le vernici all'acqua utilizzate permettono di ridurre le emissioni di solventi in atmosfera, sono contraddistinte dall'assenza di odori e tutelano la salute dell'operatore e dell'utilizzatore finale.
The reproduction of colours on paper may be different compared to the original ones, therefore these shades should be considered representative only. | Custom colour/RAL with a 20% surcharge | Water-based varnishes reduce the impact of the atmospheric emission of solvents and are characterized by the lack of scent, safeguarding the operator's and the customer's health.

ESSENZE | WOODS



Rovere naturale
Natural oak

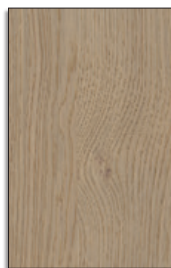

Rovere visone
Visone oak



Rovere cenere
Cenere oak



Rovere castoro
Castoro oak



Rovere carbone
Carbone oak

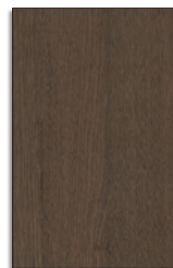

Rovere terra
Terra Oak



Noce biondo
Biondo walnut



Noce canaletto
Canaletto walnut



Rovere termotrattato
Heat-treated oak

METALLI | METALS

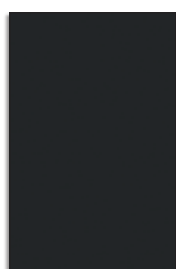

Nero
Black

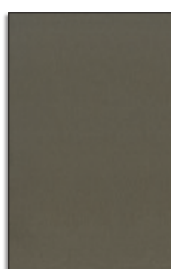

Titanio
Titanium

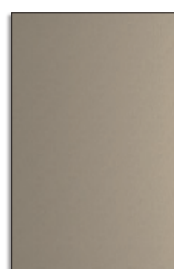

Champagne
Champagne

BORDINO CANNETÉ | GROS-GRAIN EDGING

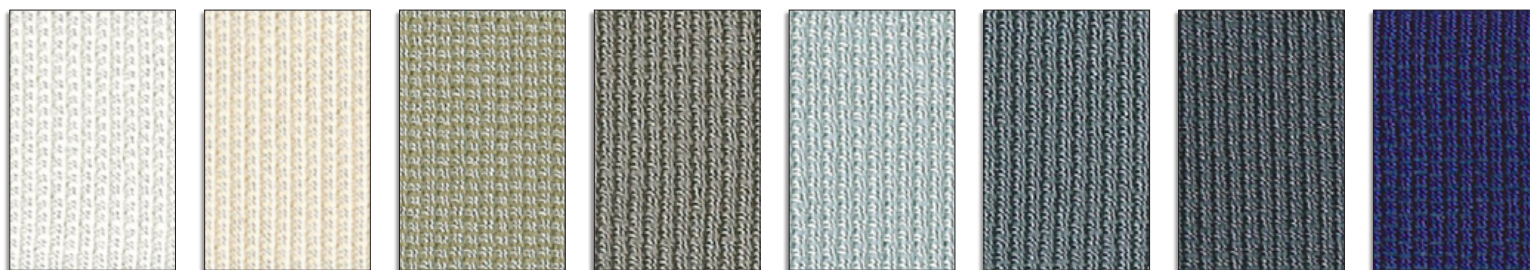

40 37 135 51 45 46 47 114

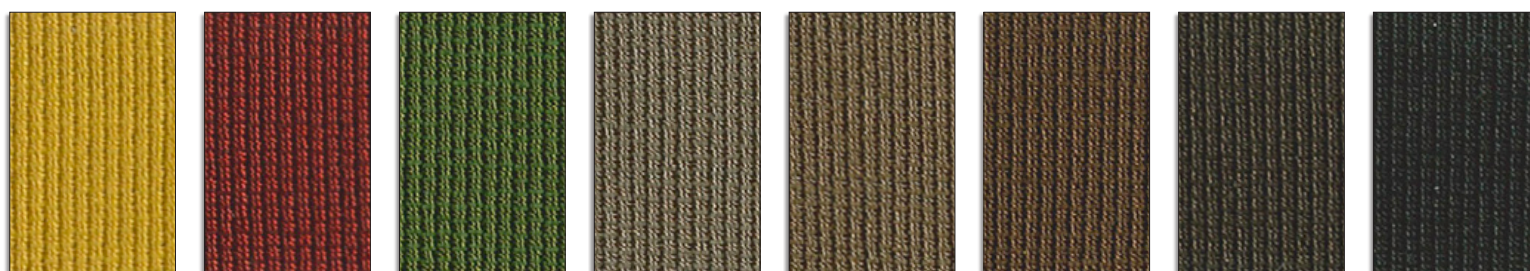

63 88 133 168 147 98 99 41

RIVESTIMENTI | UPHOLSTERY | REVÊTEMENTS | ABDECKUNGEN | REVESTIMIENTOS



Tessuto
Fabric
Tissu
Stoffbezug
Tela



Pelle
Leather
Cuir
Leder
Piel



Fintapelle
Simil leather
Similcuir
Kunstleder
Polipiel

COMPOSIZIONE INTERNA | INTERNAL COMPOSITION | COMPOSITION INTERNE | INNERE ZUSAMMENSETZUNG | COMPOSICIÓN INTERNA

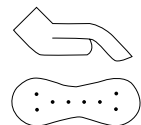

Poliuretano espanso ricoperto con lenta memoria
Expanded polyurethane foam covered with slow-memory foam layer
Polyuréthane expansé recouverts de mousse à mémoire lente
Polyurethanschaum mit strapazierfähigem Material bezogen
Poliuretano expandido revestido con espuma viscoelástica



Piuma d'oca e fiocco
Goose down and fiberfill
Plume d'oie et flocon
Gänsedaunen und Schleife
Pluma de oca y copo

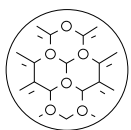

Ovatta di poliestere accoppiata a tessuto vellutino
Polyester wadding bonded with velvety fabric
Ouate de polyester couplée à un tissu velours
Polyesterwatte, mit Samtstoff kaschiert
Relleno de poliéster acoplado a tejido aterciopelado

DIVANI | SOFAS | CANAPÉS | SOFA | SOFÁS

INEMURI 6

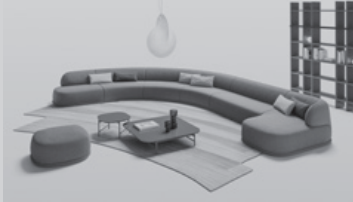

SETTANTA 46



MILTON 14



SUPERNOVA 53



PANAMA 23



SWING 61



POLDO 27



TRAMA 69



RAGGIO 38

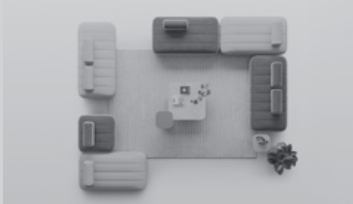

INEMURI



PIEDINI | FEET | PIEDS | FÜSSE | PATAS



STRUTTURA: costruita in abete massello e multistrato e rivestita in poliuretano espanso. Parti secondarie e non strutturali in pannelli di fibre di legno.

SEDUTA E SCHIENALE: imbottita in poliuretano espanso ad alta densità e ricoperto con lenta memoria.

PIEDINI: in plastica nera.

RIVESTIMENTO: Non disponibile in Fintapelle vintage/intreccio (Extra) e in Cartagena (Start). Sfoderabile in tessuto. Optional pianale in finitura diversa rispetto al tessuto di schienale e seduta.*

TESSUTO CLIENTE: il tessuto cliente non comprende le pelli. Per la metratura vedi listino.

STRUCTURE: made of solid spruce and plywood and covered with expanded polyurethane. Secondary and non-structural parts in fibreboard panels.

SEAT AND BACKREST: padded with high density expanded polyurethane foam and covered with slow-memory foam layer.

FEET: in black plastic.

UPHOLSTERY: Not available in Fintapelle Vintage/Intreccio (Extra) and Cartagena (Start). Removable cover in the fabric version. Optional base in a different finish compared to the fabric of backrest and seat.*

CUSTOMER FABRIC: Customer fabric does not include leather. For the required linear metres, see the price list.

STRUCTURE: construite en sapin massif et contreplaqué et rembourrée en polyuréthane expansé. Parties secondaires et non structurelles en panneaux de fibres de bois.

ASSISE ET DOSSIER: rembourrés en polyuréthane expansé à haute densité et recouverts de mousse à mémoire lente.

PIEDS: en plastique noir.

REVÊTEMENT: Non disponible dans Fintapelle vintage/Intreccio (catégorie Extra) et dans Cartagena (catégorie Start). Tissu déhoussable. Plateau avec une finition différente de celle du tissu du dossier et de l'assise.*

TISSU CLIENT: le tissu client n'inclut pas les cuirs. Pour le métrage, voir le tarif.

STRUKTUR: Fichte massiv und kaschierter Stoff, mit Polyurethanschaum. Nicht Teile aus Holzfasernplatten.

SITZFLÄCHE UND RÜCKENLEHNE: gepolstert aus Polyurethanschaum, mit strapazierfähigem Material bezogen.

FÜSSE: aus schwarzem Kunststoff.

ABDECKUNG: Nicht verfügbar im Fintapelle Vintage/Intreccio (Extra) und im Cartagena (Start). Vollständig abziehbar in der Stoffversion. Optional Einfassung mit einem anderen Stoff als dem der Rückenlehne und der Sitzfläche.*

EIGENSTOFF: Vom Kunden bereitgestellter Stoff umfasst kein Leder. Für den benötigten Stoffverbrauch siehe Preisliste.

ESTRUCTURA: construido en abeto macizo y multicapa y revestido con poliuretano expandido. Partes secundarias y no estructurales en paneles de fibra de madera.

ASIENTO Y RESPALDO: acolchado con poliuretano expandido de alta densidad y revestido con espuma viscoelástica.

PATAS: en plástico negro.

REVESTIMIENTO: No disponible en Fintapelle Vintage/Intreccio (Extra) ni en Cartagena (Start). Desenfundable en la versión tejido. A petición plataforma con tejido diferente al del respaldo y del asiento.*

TELA CLIENTE: El tejido proporcionado por el cliente no incluye pieles. Para el metraje, consulte la lista de precios.

* Optional pianale in finitura diversa rispetto al tessuto di schienale e seduta. Maggiorazione del 5% per ogni aumento di categoria tessuto. (Nel caso di schienale e seduta di categoria maggiore rispetto al pianale manterrà la medesima categoria.)

* Optional base in a different finish compared to the fabric of backrest and seat. 5% surcharge for any fabric category increase (in case of backrest and seat covered in a higher category fabric, the base will upgrade to the same category).

* Plateau avec finition différente de celle du tissu du dossier et de l'assise. Majoration de 5% pour chaque augmentation de catégorie de tissu. (Dans le cas où le dossier et l'assise seraient d'une catégorie supérieure à celle du plateau, ce dernier conservera la même catégorie.)

* Optional Sitzbezug aus einem anderen Stoff als der Rückenlehne und der Sitzfläche. Aufpreis von 5% für jede höhere Stoffkategorie. (Wenn Rückenlehne und Sitzfläche einer höheren Preiskategorie angehören als der Sitzbezug, bleibt die Kategorie unverändert.)

* Plataforma a petición con tejido diferente al del respaldo y del asiento. Recargo del 5% por cada aumento de categoría del tejido. (En caso de que el respaldo y el asiento sean de una categoría de precio superior a la de la plataforma, se mantendrá la misma categoría.)

INEMURI

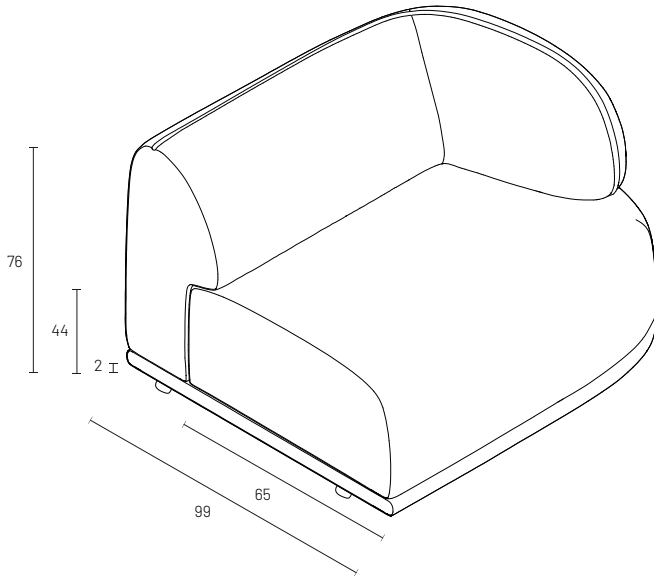
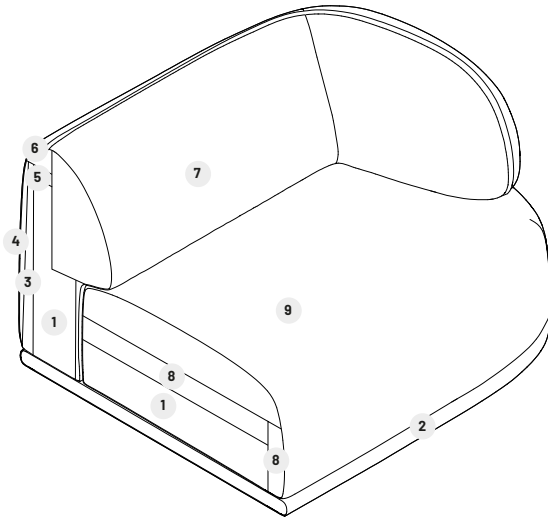

abete massello e multistrato

- 1 solid spruce and plywood
sapin massif et contreplaqué
Fichte massiv und kaschierter Stoff
abeto macizo y multicapa

accoppiato grigio 8 mm

- 2 8 mm grey laminated fabric
doublage gris 8 mm
kaschierter Stoff grau 8 mm
material grau 8 mm acoplado

poliuretano D21 SH3

- 3 polyurethane D21 SH3
polyuréthane D21 SH3
Polyurethan D21 SH3
poliuretano D21 SH3

poliuretano D40 T

- 4 polyurethane D40 T
polyuréthane D40 T
Polyurethan D40 T
poliuretano D40 T

poliuretano D35 M

- 5 polyurethane D35 M
polyuréthane D35 M
Polyurethan D35 M
poliuretano D35 M

falda 400 gr

- 6 400 g layer
nappe 400 g
400 g Schräge
faldón 400 gr

poliuretano D21 SH3 rivestito resinato GR 200 + VELL





- 7 polyurethane D21 SH3 covered with GR 200 + VELL resin coating
polyuréthane D21 SH3 revêtu de résiné GR 200 + VELL
Polyurethan D21 SH3 mit Harzbeschichtung GR. 200 + VELL bezogen
poliuretano D21 SH3 recubierto con resina GR 200 + VELL

poliuretano D32 ALX

- 8 polyurethane D32 ALX
polyuréthane D32 ALX
Polyurethan D32 ALX
poliuretano D32 ALX

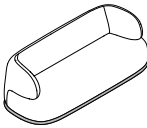
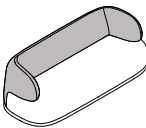
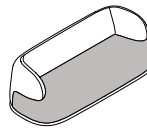
poliuretano D35 M rivestito resinato GR 200 + VELL

- 9 polyurethane D35 M covered with GR 200 + VELL resin coating
polyuréthane D35 M revêtu de résiné GR 200 + VELL
Polyurethan D35 M mit Harzbeschichtung GR. 200 + VELL bezogen
poliuretano D35 M recubierto con resina GR 200 + VELL

			
	PIANALE BASE PLATEAU PLATTFORM PLATAFORMA	SCHIENALE BACKREST DOSSIER RÜCKENLEHNE RESPALDO	SEDUTA SEAT ASSISSE SITZFLÄCHE ASIENTO
SFODERABILE REMOVABLE DÉHOUSSABLE ABZIEHBAR DESENFUNDABLE	-		
NON SFODERABILE NON REMOVABLE NON DÉHOUSSABLE NICHT ABZIEHBAR NO DESENFUNDABLE		-	-

INEMURI

moduli | units | modules | module | módulos

divano 2,5 posti
2.5-seat sofa
canapé 2,5 places
Sofa 2,5 Sitze
sofa 2,5 plazos

L W	H H	P D	CODICE CODE	Basic	Start	Extra	Light	Super	t-cliente com-fabric	ml l.mt.	m ³ kg
--------	--------	--------	----------------	-------	-------	-------	-------	-------	-------------------------	-------------	----------------------

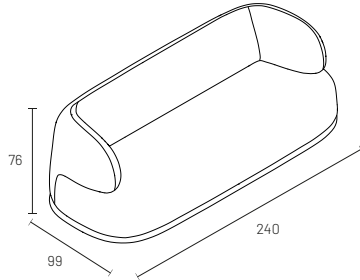

240	76	99	DI01INAB000	2.898	3.090	3.283	3.411	3.753	2.523	10	1,990
-----	----	----	-------------	-------	-------	-------	-------	-------	-------	----	-------

divano 3 posti
3-seat sofa
canapé 3 places
Sofa 3 Sitze
sofa 3 plazos

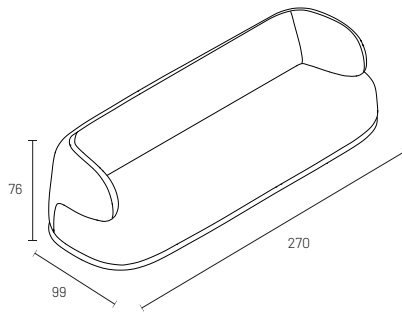

270	76	99	DI01INAD000	3.391	3.622	3.853	4.007	4.417	2.927	11	2,198
-----	----	----	-------------	-------	-------	-------	-------	-------	-------	----	-------

laterale 1 posto
1-seat side element
latéral 1 place
seitliches Modul 1 Sitz
módulo lateral 1 plazo

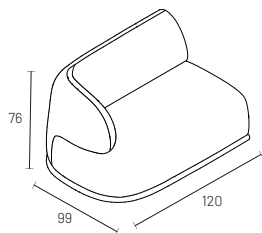

dx rh droite re. dcha	120	76	99	DI01INBAD00	2.136	2.241	2.346	2.416	2.603	1.956	7,5	145
sx lh gauche li. izda	120	76	99	DI01INBAS00	2.136	2.241	2.346	2.416	2.603	1.956	7,5	145

Moduli rappresentati sx se non specificato diversamente. | Units represented as lh unless otherwise specified. | Modules représentés à gauche sauf indication contraire. | Module links dargestellt, sofern nicht anders angegeben. | Módulos representados izquierdos, excepto indicación contraria.

laterale 2 posti
2-seat side element
latéral 2 places
seitliches Modul 2 Sitze
módulo lateral 2 plazas

L W	H H	P D	CODICE CODE	Basic	Start	Extra	Light	Super	t-cliente com-fabric	ml l.mt.	m ³ kg
--------	--------	--------	----------------	-------	-------	-------	-------	-------	-------------------------	-------------	----------------------

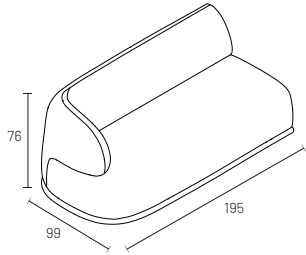

dx rh droite re. dcha	195	76	99	DI01INBBD00	2.589	2.737	2.886	2.985	3.249	2.366	9	1,6 68
sx lh gauche li. izda	195	76	99	DI01INBBS00	2.589	2.737	2.886	2.985	3.249	2.366	9	1,6 68

centrale 2,5 posti
2.5-seat central element
central 2,5 places
zentrales Modul 2,5 Sitze
módulo central 2,5 plazas

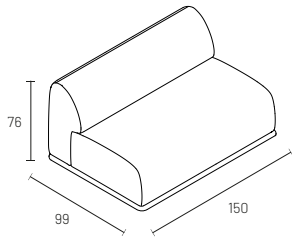

	150	76	99	DI01INCC000	2.264	2.439	2.614	2.731	3.042	1.928	6	1,25 45
--	-----	----	----	-------------	-------	-------	-------	-------	-------	-------	---	------------

centrale 3 posti
3-seat central element
central 3 places
zentrales Modul 3 Sitze
módulo central 3 plazas

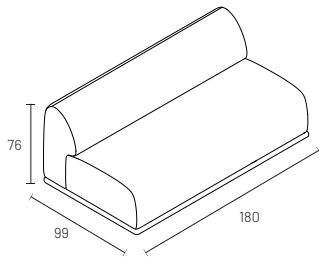

	180	76	99	DI01INCD000	2.654	2.864	3.074	3.214	3.587	2.240	7	1,5 56
--	-----	----	----	-------------	-------	-------	-------	-------	-------	-------	---	-----------

INEMURI

moduli | units | modules | module | módulos

angolo 2 posti
2-seat corner
angle 2 places
Eckeleement, 2 Sitze
elemento ángulo, 2 plazas

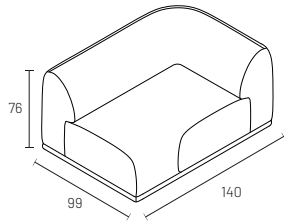

rappresentato dx
rh in the figure
illustré à droite
rechts dargestellt
representado a la derecha

L W	H H	P D	CODICE CODE	Basic	Start	Extra	Light	Super	t-cliente com-fabric	ml l.mt.	m ³ kg
--------	--------	--------	----------------	-------	-------	-------	-------	-------	-------------------------	-------------	----------------------

dx rh droite re. dcha sx lh gauche li. izda	140	76	99	DI01INFBD00	2.305	2.427	2.550	2.631	2.849	1.833	8	1,2 50
	140	76	99	DI01INFBS00	2.305	2.427	2.550	2.631	2.849	1.833	8	1,2 50

angolo 30°
30° corner
angle 30°
Eckeleement 30°
elemento ángulo 30°

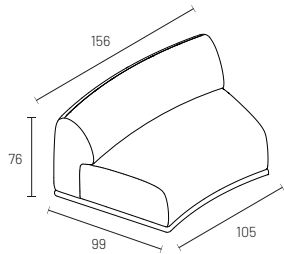

	156	76	99	DI01INFBA00	2.279	2.454	2.629	2.745	3.057	1.872	6	1,2 45
--	------------	----	----	-------------	--------------	--------------	--------------	--------------	--------------	--------------	----------	-----------

terminale
end unit
el. terminal
Abschlusselement
elemento terminal

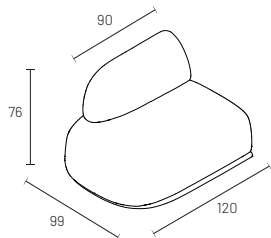

dx rh droite re. dcha sx lh gauche li. izda	120	76	99	DI01INHOD00	2.209	2.384	2.559	2.675	2.987	1.820	5,7	1 45
	120	76	99	DI01INHOS00	2.209	2.384	2.559	2.675	2.987	1.820	5,7	1 45

Moduli rappresentati sx se non specificato diversamente. | Units represented as lh unless otherwise specified. | Modules représentés à gauche sauf indication contraire. | Module links dargestellt, sofern nicht anders angegeben. | Módulos representados izquierdos, excepto indicación contraria.

chaise longue
chaise longue
chaise longue
chaise longue
chaise longue

L W	H H	P D	CODICE CODE	Basic	Start	Extra	Light	Super	t-cliente com-fabric	ml l.mt.	m ³ kg
--------	--------	--------	----------------	-------	-------	-------	-------	-------	-------------------------	-------------	----------------------

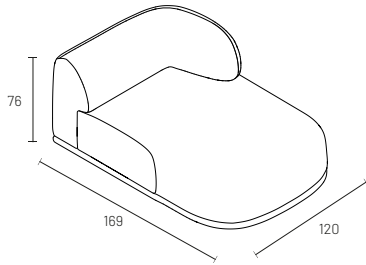

dx rh droite re. dcha	120	76	169	DI01INIOD00	2.555	2.720	2.885	2.995	3.289	2.238	7,5	1,7 60
sx lh gauche li. izda	120	76	169	DI01INIOS00	2.555	2.720	2.885	2.995	3.289	2.238	7,5	1,7 60

rappresentato dx
rh in the figure
illustré à droite
rechts dargestellt
representado a la derecha

pouf
pouf
pouf
pouf
pouf

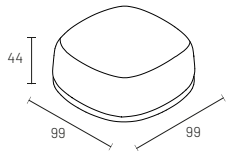

	99	44	99	DI01INLA000	1.231	1.301	1.371	1.418	1.542	1.128	4,5	0,5 35
--	----	----	----	-------------	-------	-------	-------	-------	-------	-------	-----	-----------

cuscino
cushion
coussin
Kissen
cojín

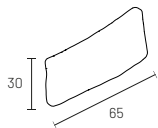

	65	30	16	DI01INX0000	151	165	179	188	213	120	0,8	0,03 0,3
--	----	----	----	-------------	-----	-----	-----	-----	-----	-----	-----	-------------

composizione 1 (rappresentata dx)
 composition 1 (rh in the picture)
 composition 1 (illustré à droite)
 Zusammenstellung 1 (rechts dargestellt)
 Composición 1 (representada a la derecha)

L W	H H	P D	CODICE CODE	Basic	Start	Extra	Light	Super	t-cliente com-fabric	ml l.mt.	m³ kg
--------	--------	--------	----------------	-------	-------	-------	-------	-------	-------------------------	-------------	----------

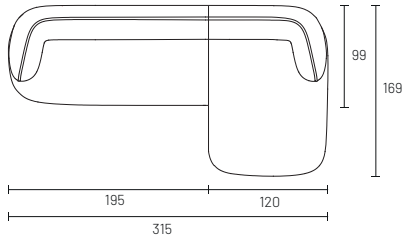

315	76	169	INEMC1	5.144	5.457	5.771	5.980	6.538	4.604	16,5	3,3 128
-----	----	-----	--------	-------	-------	-------	-------	-------	-------	------	------------

composizione 2 (rappresentata dx)
 composition 2 (rh in the picture)
 composition 2 (illustré à droite)
 Zusammenstellung 2 (rechts dargestellt)
 Composición 2 (representada a la derecha)

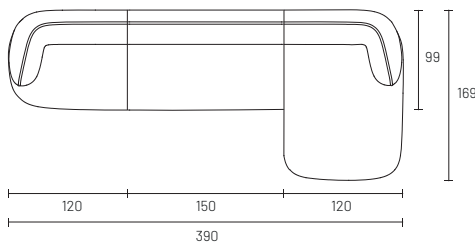

390	76	169	INEMC2	6.955	7.400	7.845	8.142	8.934	6.122	21	3,95 150
-----	----	-----	--------	-------	-------	-------	-------	-------	-------	----	-------------

composizione 3 (rappresentata sx)
 composition 3 (lh in the picture)
 composition 3 (illustré à gauche)
 Zusammenstellung 3 (links dargestellt)
 Composición 3 (representada a la izquierda)

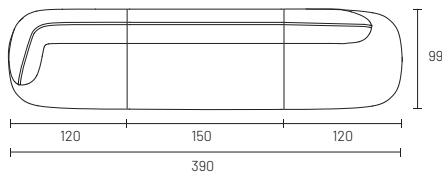

390	76	99	INEMC3	6.609	7.064	7.519	7.822	8.632	3.884	19,2	3,25 135
-----	----	----	--------	-------	-------	-------	-------	-------	-------	------	-------------

composizione 4 (rappresentata dx)
 composition 4 (rh in the picture)
 composition 4 (illustré à droite)
 Zusammenstellung 4 (rechts dargestellt)
 Composición 4 (representada a la derecha)

L W	H H	P D	CODICE CODE	Basic	Start	Extra	Light	Super	t-cliente com-fabric	ml l.mt.	m ³ kg
--------	--------	--------	----------------	-------	-------	-------	-------	-------	-------------------------	-------------	----------------------

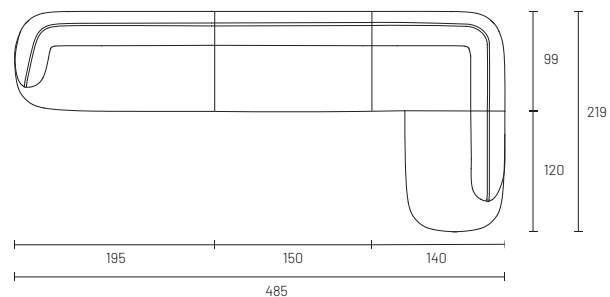

485	76	219	INEMC4	9.367	9.987	10.609	11.022	12.127	6.127	28,7	5,05 208
-----	----	-----	--------	-------	-------	--------	--------	--------	-------	------	-------------

composizione 5 (rappresentata dx)
 composition 5 (rh in the picture)
 composition 5 (illustré à droite)
 Zusammenstellung 5 (rechts dargestellt)
 Composición 5 (representada a la derecha)

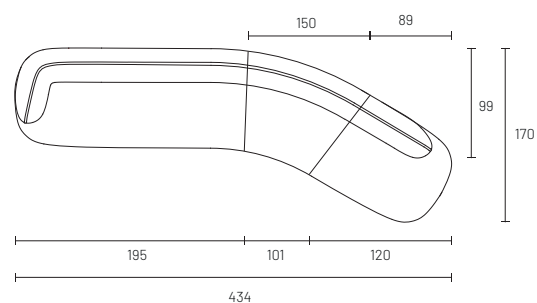

434	76	170	INEMC5	7.077	7.575	8.074	8.405	9.293	4.238	20,7	3,8 158
-----	----	-----	--------	-------	-------	-------	-------	-------	-------	------	------------

composizione 6 (rappresentata dx)
 composition 6 (rh in the picture)
 composition 6 (illustré à droite)
 Zusammenstellung 6 (rechts dargestellt)
 Composición 6 (representada a la derecha)

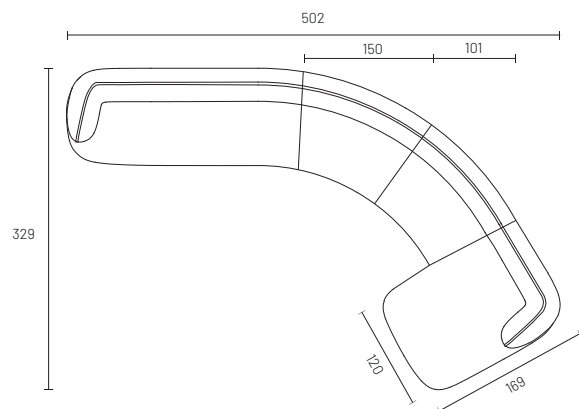

502	76	329	INEMC6	9.702	10.365	11.029	11.470	12.652	8.348	32,5	5,7 228
-----	----	-----	--------	-------	--------	--------	--------	--------	-------	------	------------

MILTON



PIEDINI | FEET | PIEDS | FÜSSE | PATAS



STRUTTURA: costruita in abete massello e multistrato e rivestita in poliuretano espanso. Parti secondarie e non strutturali in pannelli di fibre di legno.

SEDUTE: imbottite in poliuretano espanso ad alta densità e ricoperto con lenta memoria.

SCHIENALI E BRACCIOLI: imbottiti in piuma d'oca e fiocco.

CORDONCINO: standard in bordino cannettato o con lo stesso tessuto del rivestimento.

PIEDINI: in metallo verniciato nero. Disponibili in champagne, titanio o laccato opaco con maggiorazione: 25€ cadauno.

RIVESTIMENTO: sfoderabile in tessuto, parzialmente sfoderabile nella versione in pelle (solo cuscinate).

TESSUTO CLIENTE: il tessuto cliente non comprende le pelli. Per la metratura vedi listino.

STRUCTURE: made of solid spruce and plywood and covered with expanded polyurethane. Secondary and non-structural parts in fibreboard panels.

SEATS: padded with high density expanded polyurethane foam and covered with slow-memory foam layer.

BACKRESTS AND ARMRESTS: padded with goose down and fiberfill.

RIBBON EDGE: standard with ribbed piping or in the same fabric as the upholstery.

FEET: in black varnished metal. Also available in champagne, titanium, or matte lacquered with an additional charge of €25 each feet.

UPHOLSTERY: removable cover in the fabric version, partially removable in the leather version (cushions only).

CUSTOMER FABRIC: Customer fabric does not include leather. For the required linear metres, see the price list.

STRUCTURE: construite en sapin massif et contreplaqué et rembourrée en polyuréthane expansé. Parties secondaires et non structurelles en panneaux de fibres de bois.

ASSISES: rembourrés en polyuréthane expansé à haute densité et recouverts de mousse à mémoire de forme.

DOSSIERS ET ACCOUDOIRS: rembourrés en plume d'oie et flocon.

CORDON: standard avec passepoil côtelé ou avec le même tissu que le revêtement.

PIEDS: en métal laqué en noir. Disponibles en champagne, titane ou laqué mat avec supplément : 25 € chacun.

REVÊTEMENT: tissu déhoussable, partiellement déhoussable en version cuir (seulement les coussins).

TISSU CLIENT: le tissu client n'inclut pas les cuirs. Pour le métrage, voir le tarif.

STRUKTUR: Fichte massiv und kaschierter Stoff, mit Polyurethanschaum. Nicht Teile aus Holzfasernplatten.

SITZFLÄCHEN: gepolstert aus Polyurethanschaum, mit strapazierfähigem Material bezogen.

RÜCKENLEHNEN UND ARMLEHNEN: gepolstert aus Gänsedaunen und Schleife.

STOFFBORDE: standard Stoffborde Typ cannété oder mit dem gleichen Stoff des Bezuges.

FÜSSE: aus schwarz lackiertem Metall. Erhältlich auch in Champagne, Titan oder Mattlack gegen Aufpreis von 25 € pro Fuß.

ABDECKUNG: Vollständig abziehbar in der Stoffversion, bei der Lederversion teilweise abnehmbar (nur Kissen).

EIGENSTOFF: Vom Kunden bereitgestellter Stoff umfasst kein Leder. Für den benötigten Stoffverbrauch siehe Preisliste.

ESTRUCTURA: construido en abeto macizo y multicapa y revestido con poliuretano expandido. Partes secundarias y no estructurales en paneles de fibra de madera.

ASIENTOS: acolchado con poliuretano expandido de alta densidad y revestidos con espuma viscoelástica.

RESPALDOS Y BRAZOS: acolchados con pluma de oca y copo.

FRANJA: estándar franja en cannété o con el mismo tejido del revestimiento.

PATAS: en metal lacado negro. Disponibles en champagne, titanio o lacado mate con recargo de 25 € cada uno.

REVESTIMIENTO: desenfundable en la versión tejido, parcialmente desenfundable en la versión piel (solo cojines).

TELA CLIENTE: El tejido proporcionado por el cliente no incluye pieles. Para el metraje, consulte la lista de precios.

MILTON

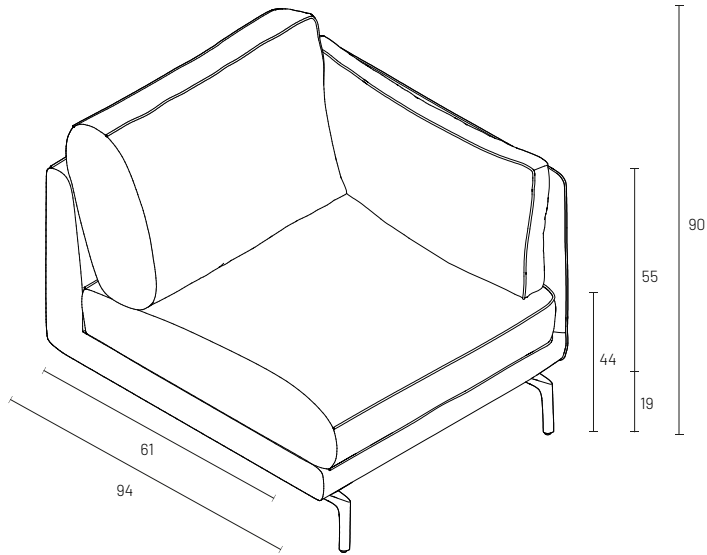
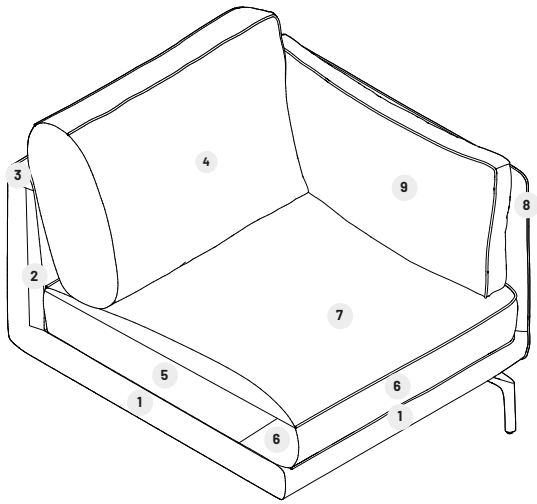

abete massello e multistrato

- 1 solid spruce and plywood
- sapin massif et contreplaqué
- Fichte massiv und kaschierter Stoff
- abeto macizo y multicapa

poliuretano D25 T

- 2 polyurethane D25 T
- polyuréthane D25 T
- Polyurethan D25 T
- poliuretano D25 T

poliuretano D40 PK

- 3 polyurethane D40 PK
- polyuréthane D40 PK
- Polyurethan D40 PK
- poliuretano D40 PK

piuma d'oca e fiocco

- 4 goose down and fiberfill
- plume d'oie et flocon
- Gänsefeder und Schleife
- pluma de ganso y lazo

poliuretano D40 PFPFR

- 5 polyurethane D40 PFPFR
- polyuréthane D40 PFPFR
- Polyurethan D40 PFPFR
- poliuretano D40 PFPFR

poliuretano D40 T rivestito tecnoform GR 300 + VELL

- 6 polyurethane D40 T covered with Tecnoform GR 300 + VELL
- polyuréthane D40 T revêtu de tecnoform GR 300 + VELL
- Polyurethan D40 T mit Tecnoform GR 300 + VELL bezogen
- poliuretano D40 T revestido con Tecnoform GR 300 + VELL

poliuretano D38 UNIQUE

- 7 polyurethane D38 UNIQUE
- polyuréthane D38 UNIQUE
- Polyurethan D38 UNIQUE
- poliuretano D38 UNIQUE

poliuretano D21 T

- 8 polyurethane D21 T
- polyuréthane D21 T
- Polyurethan D21 T
- poliuretano D21 T

piuma d'oca e fiocco

- 9 goose down and fiberfill
- plume d'oie et flocon
- Gänsefeder und Schleife
- pluma de ganso y lazo

	STRUTTURA STRUCTURE STRUCTURE AUFBAU ESTRUCTURA	SCHIENALE BACKREST DOSSIER RÜCKENLEHNE RESPALDO	SEDUTA SEAT ASSISE SITZFLÄCHE ASIENTO
SFODERABILE REMOVABLE DÉHOUSSABLE ABZIEHBAR DESENFUNDABLE			
NON SFODERABILE NON REMOVABLE NON DÉHOUSSABLE NICHT ABZIEHBAR NO DESENFUNDABLE		-	-

divano 2 posti
2-seat sofa
canapé 2 places
Sofa 2 Sitze
sofa 2 plazos

L W	H H	P D	CODICE CODE	Basic	Start	Extra	Light	Super	K	W	t-cliente com-fabric	ml l.mt.	m ³ kg
--------	--------	--------	----------------	-------	-------	-------	-------	-------	---	---	-------------------------	-------------	----------------------

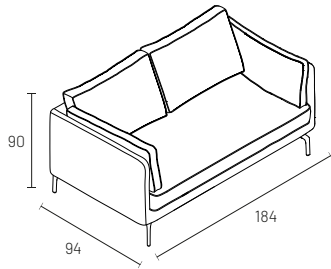

184	90	94	DI01MIAB000	2.834	3.016	3.198	3.320	3.643	4.818	5.786	2.482	11,5	1,08 69
-----	----	----	-------------	-------	-------	-------	-------	-------	-------	-------	-------	------	------------

divano 2,5 posti
2.5-seat sofa
canapé 2,5 places
Sofa 2,5 Sitze
sofa 2,5 plazos

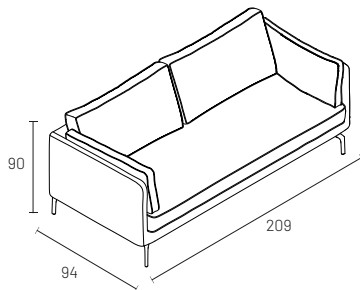

209	90	94	DI01MIAC000	2.856	3.038	3.219	3.340	3.663	4.978	5.972	2.578	12	1,16 74
-----	----	----	-------------	-------	-------	-------	-------	-------	-------	-------	-------	----	------------

divano 3 posti
3-seat sofa
canapé 3 places
Sofa 3 Sitze
sofa 3 plazos

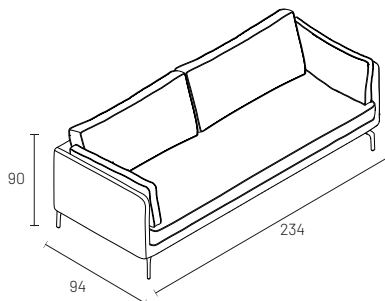

234	90	94	DI01MIAD000	2.987	3.173	3.360	3.484	3.816	5.015	6.006	2.622	12,5	1,3 85
-----	----	----	-------------	-------	-------	-------	-------	-------	-------	-------	-------	------	-----------

Piedini standard verniciati neri, disponibili in champagne, titanio o laccato opaco con maggiorazione: 25 € cadauno. | Standard feet painted black, also available in champagne, titanium, or matte lacquered with an additional charge of € 25 each. | Pieds standard laqué en noir, disponibles en champagne, titane ou laqué mat avec supplément : 25 € chacun. | Standardfüße schwarz lackiert, erhältlich in Champagne, Titan oder Mattlack gegen Aufpreis von 25 € pro Fuß. | Patas estándar pintados en negro, disponibles en champagne, titanio o lacado mate con un recargo de 25 € cada uno.

laterale 1 posto

1-seat side element
latéral 1 place
seitliches Modul 1 Sitz
módulo lateral 1 plazo

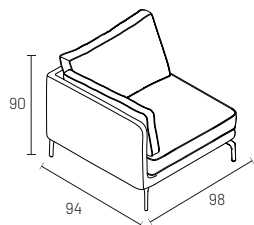

	L W	H H	P D	CODICE CODE	Basic	Start	Extra	Light	Super	K	W	t-cliente com-fabric	ml l.mt.	m³ kg
dx rh droite re. dcha	98	90	94	DI01MIBAD00	1.807	1.889	1.972	2.027	2.174	2.897	3.363	1.775	5,5	0,53 35
sx lh gauche li. izda	98	90	94	DI01MIBAS00	1.807	1.889	1.972	2.027	2.174	2.897	3.363	1.775	5,5	0,53 35

laterale 2 posti

2-seat side element
latéral 2 places
seitliches Modul 2 Sitze
módulo lateral 2 plazos

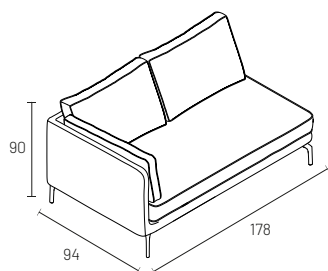

dx rh droite re. dcha	178	90	94	DI01MIBBD00	2.633	2.808	2.983	3.100	3.411	4.543	5.473	2.297	11	1,05 59
sx lh gauche li. izda	178	90	94	DI01MIBBS00	2.633	2.808	2.983	3.100	3.411	4.543	5.473	2.297	11	1,05 59

laterale 2,5 posti

2.5-seat side element
latéral 2,5 places
seitliches Modul 2,5 Sitze
módulo lateral 2,5 plazos

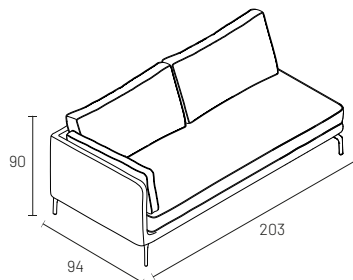

dx rh droite re. dcha	203	90	94	DI01MIBCD00	2.659	2.831	3.003	3.117	3.422	4.530	5.442	2.328	11,5	1,13 64
sx lh gauche li. izda	203	90	94	DI01MIBCS00	2.659	2.831	3.003	3.117	3.422	4.530	5.442	2.328	11,5	1,13 64

Moduli rappresentati sx se non specificato diversamente. | Piedini standard verniciati neri, disponibili in champagne, titanio o laccato opaco con maggiorazione: 25 € cadauno. | Units represented as lh unless otherwise specified. | Standard feet painted black, also available in champagne, titanium, or matte lacquered with an additional charge of € 25 each. | Modules représentés à gauche sauf indication contraire. | Pieds standard laqué en noir, disponibles en champagne, titane ou laqué mat avec supplément : 25 € chacun. | Module links dargestellt, sofern nicht anders angegeben. | Standardfüße schwarz lackiert, erhältlich in Champagne, Titan oder Mattlack gegen Aufpreis von 25 € pro Fuß. | Módulos representados izquierdos, excepto indicación contraria. | Patas estándar pintados en negro, disponibles en champagne, titanio o lacado mate con un recargo de 25 € cada uno.

laterale 3 posti
3-seat side element
latéral 3 places
seitliches Modul 3 Sitze
módulo lateral 3 plazas

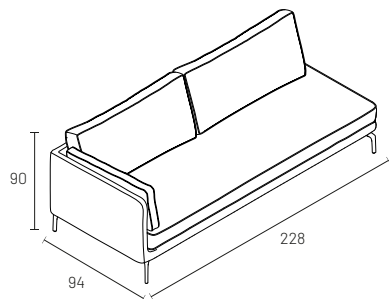

	L	H	P	CODICE	Basic	Start	Extra	Light	Super	K	W	t-cliente	ml	m³
	W	H	D	CODE								com-fabric	l.mt.	kg
dx rh droite re. dcha	228	90	94	DI01MIBDD00	2.707	2.888	3.070	3.191	3.513	4.682	5.647	2.353	12	1,57 75
sx lh gauche li. izda	228	90	94	DI01MIBDS00	2.707	2.888	3.070	3.191	3.513	4.682	5.647	2.353	12	1,57 75

isola
sectional element
méridienne
chaise longue
chaise longue

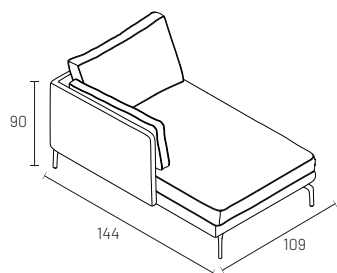

dx rh droite re. dcha	109	90	144	DI01MIDOD00	2.376	2.503	2.630	2.714	2.940	3.773	4.449	2.143	8,5	1,2 59
sx lh gauche li. izda	109	90	144	DI01MIDOS00	2.376	2.503	2.630	2.714	2.940	3.773	4.449	2.143	8,5	1,2 59

meridiana
chaise longue
chaise longue
Ottomane
peninsula

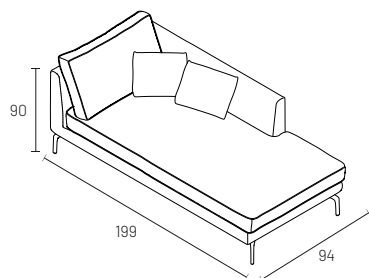

dx rh droite re. dcha	94	90	199	DI01MIEOD00	2.433	2.582	2.730	2.829	3.093	4.059	4.848	2.153	10	1,4 74
sx lh gauche li. izda	94	90	199	DI01MIEOS00	2.433	2.582	2.730	2.829	3.093	4.059	4.848	2.153	10	1,4 74

rappresentato dx
rh in the figure
illustré à droite
rechts dargestellt
representado a la derecha

Moduli rappresentati sx se non specificato diversamente. | Piedini standard verniciati neri, disponibili in champagne, titanio o laccato opaco con maggiorazione: 25 € cadauno. | Units represented as lh unless otherwise specified. | Standard feet painted black, also available in champagne, titanium, or matte lacquered with an additional charge of € 25 each. | Modules représentés à gauche sauf indication contraire. | Pieds standard laqué en noir, disponibles en champagne, titane ou laqué mat avec supplément : 25 € chacun. | Module links dargestellt, sofern nicht anders angegeben. | Standardfüße schwarz lackiert, erhältlich in Champagne, Titan oder Mattlack gegen Aufpreis von 25 € pro Fuß. | Módulos representados izquierdos, excepto indicación contraria. | Patas estándar pintados en negro, disponibles en champagne, titanio o lacado mate con un recargo de 25 € cada uno.

pouf
pouf
pouf
pouf
pouf

L W	H H	P D	CODICE CODE	Basic	Start	Extra	Light	Super	K	W	t-cliente com-fabric	ml l.mt.	m ³ kg
--------	--------	--------	----------------	-------	-------	-------	-------	-------	---	---	-------------------------	-------------	----------------------

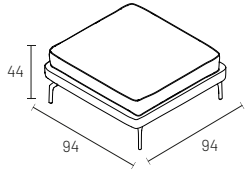

94	44	94	DI01MILA000	1.193	1.249	1.305	1.343	1.442	1.840	2.138	1.121	3,5	0,3 15
----	----	----	-------------	-------	-------	-------	-------	-------	-------	-------	-------	-----	-----------

poltrona
armchair
fauteuil
Sessel
sillón

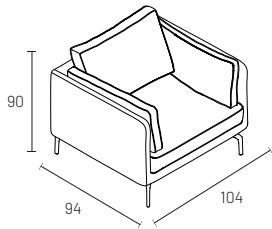

104	90	94	DI01MIMA000	2.123	2.228	2.333	2.403	2.590	3.290	3.848	1.942	6,5	0,53 35
-----	----	----	-------------	-------	-------	-------	-------	-------	-------	-------	-------	-----	------------

cuscino
cushion
coussin
Kissen
cojín

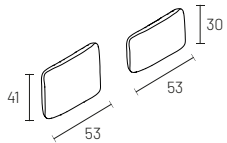

53	41	20	DI01MIX0000	110	120	129	136	153	212	264	89	0,7	0,03 0,3
53	30	20	DI01MIX0100	109	118	128	134	152	211	262	87	0,7	0,03 0,3

portariviste in cuoio
 magazine rack in hard leather
 porte-revues en cuir
 Zeitschriftenhalter in Hartleder
 revistero en cuero

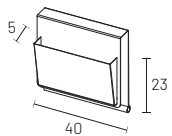

L W	H H	P D	CODICE CODE	Prezzo Price	m ³ kg
40	23	5	DI0191X1000	190	0,02 0,8

composizione 1 (rappresentata dx)
 composition 1 (rh in the picture)
 composition 1 (illustré à droite)
 Zusammenstellung 1 (rechts dargestellt)
 Composición 1 (representada a la derecha)

L W	H H	P D	CODICE CODE	Basic	Start	Extra	Light	Super	K	W	t-cliente com-fabric	ml l.mt.	m ³ kg
--------	--------	--------	----------------	-------	-------	-------	-------	-------	---	---	-------------------------	-------------	----------------------

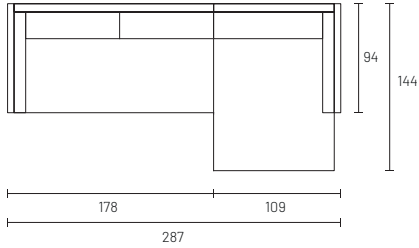

287	90	144	MILTC1	5.009	5.311	5.613	5.814	6.351	8.316	9.922	4.440	19,5	2,25 118
-----	----	-----	--------	-------	-------	-------	-------	-------	-------	-------	-------	------	-------------

composizione 2 (rappresentata dx)
 composition 2 (rh in the picture)
 composition 2 (illustré à droite)
 Zusammenstellung 2 (rechts dargestellt)
 Composición 2 (representada a la derecha)

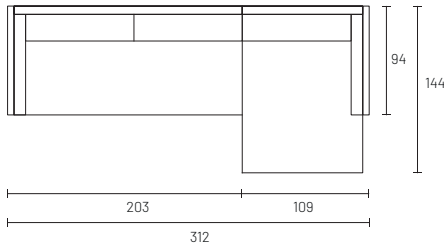

312	90	144	MILTC2	5.035	5.334	5.633	5.831	6.362	8.303	9.891	4.471	20	2,33 123
-----	----	-----	--------	-------	-------	-------	-------	-------	-------	-------	-------	----	-------------

composizione 3 (rappresentata dx)
 composition 3 (rh in the picture)
 composition 3 (illustré à droite)
 Zusammenstellung 3 (rechts dargestellt)
 Composición 3 (representada a la derecha)

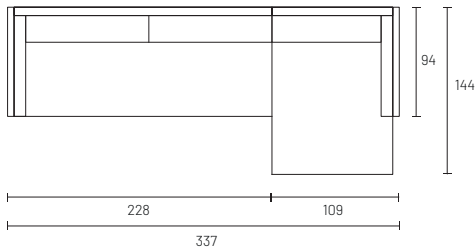

337	90	144	MILTC3	5.083	5.391	5.700	5.905	6.453	8.455	10.096	4.496	20,5	2,77 134
-----	----	-----	--------	-------	-------	-------	-------	-------	-------	--------	-------	------	-------------

composizione 4 (rappresentata dx)
 composition 4 (rh in the picture)
 composition 4 (illustré à droite)
 Zusammenstellung 4 (rechts dargestellt)
 Composición 4 (representada a la derecha)

L W	H H	P D	CODICE CODE	Basic	Start	Extra	Light	Super	K	W	t-cliente com-fabric	ml l.mt.	m³ kg
--------	--------	--------	----------------	-------	-------	-------	-------	-------	---	---	-------------------------	-------------	----------

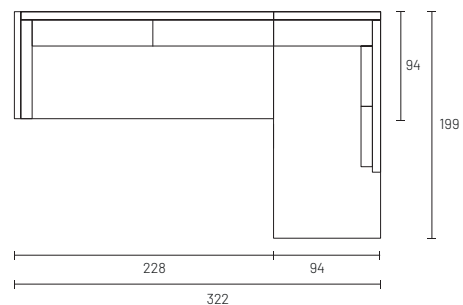

322	90	199	MILTC4	5.140	5.470	5.800	6.020	6.606	8.741	10.495	4.506	22	2,97 149
-----	----	-----	--------	-------	-------	-------	-------	-------	-------	--------	-------	----	-------------

PANAMA



PIEDINI | FEET | PIEDS | FÜSSE | PATAS



STRUTTURA: costruita in abete massello e multistrato e rivestita in poliuretano espanso. Parti secondarie e non strutturali in pannelli di fibre di legno.

SEDUTA E SCHIENALE: imbottita in poliuretano espanso ad alta densità e ricoperto con lenta memoria.

CORDONCINO: standard in bordino cannettato o con lo stesso tessuto del rivestimento.

PIEDINI: in metallo verniciato nero. Disponibili in champagne, titanio o laccato opaco con maggiorazione: 25€ cadauno.

RIVESTIMENTO: sfoderabile in tessuto, parzialmente sfoderabile nella versione in pelle (solo cuscinate).

TESSUTO CLIENTE: il tessuto cliente non comprende le pelli. Per la metratura vedi listino.

STRUCTURE: made of solid spruce and plywood and covered with expanded polyurethane. Secondary and non-structural parts in fibreboard panels.

SEAT AND BACKREST: padded with high density expanded polyurethane foam and covered with slow-memory foam layer.

RIBBON EDGE: standard with ribbed piping or in the same fabric as the upholstery.

FEET: in black varnished metal. Also available in champagne, titanium, or matte lacquered with an additional charge of €25 each feet.

UPHOLSTERY: removable cover in the fabric version, partially removable in the leather version (cushions only).

CUSTOMER FABRIC: Customer fabric does not include leather. For the required linear metres, see the price list.

STRUCTURE: construite en sapin massif et contreplaqué et rembourrée en polyuréthane expansé. Parties secondaires et non structurelles en panneaux de fibres de bois.

ASSISE ET DOSSIER: rembourrés en polyuréthane expansé à haute densité et recouverts de mousse à mémoire lente.

CORDON: standard avec passepoil côtelé ou avec le même tissu que le revêtement.

PIEDS: en métal laqué en noir. Disponibles en champagne, titane ou laqué mat avec supplément : 25 € chacun.

REVÊTEMENT: tissu déhoussable, partiellement déhoussable en version cuir (seulement les coussins).

TISSU CLIENT: le tissu client n'inclut pas les cuirs. Pour le métrage, voir le tarif.

STRUKTUR: Fichte massiv und kaschierter Stoff, mit Polyurethanschaum. Nicht Teile aus Holzfasernplatten.

SITZFLÄCHE UND RÜCKENLEHNE: gepolstert aus Polyurethanschaum, mit strapazierfähigem Material bezogen.

STOFFBORDE: standard Stoffborde Typ canneté oder mit dem gleichen Stoff des Bezuges.

FÜSSE: aus schwarz lackiertem Metall. Erhältlich auch in Champagne, Titan oder Mattlack gegen Aufpreis von 25 € pro Fuß.

ABDECKUNG: Vollständig abziehbar in der Stoffversion, bei der Lederversion teilweise abnehmbar (nur Kissen).

EIGENSTOFF: Vom Kunden bereitgestellter Stoff umfasst kein Leder. Für den benötigten Stoffverbrauch siehe Preisliste.

ESTRUCTURA: construido en abeto macizo y multicapa y revestido con poliuretano expandido. Partes secundarias y no estructurales en paneles de fibra de madera.

ASIENTO Y RESPALDO: acolchado con poliuretano expandido de alta densidad y revestida con espuma viscoelástica.

FRANJA: estándar franja en canneté o con el mismo tejido del revestimiento.

PATAS: en metal lacado negro. Disponibles en champagne, titanio o lacado mate con recargo de 25 € cada uno.

REVESTIMIENTO: desenfundable en la versión tejido, parcialmente desenfundable en la versión piel (solo cojines).

TELA CLIENTE: El tejido proporcionado por el cliente no incluye pieles. Para el metraje, consulte la lista de precios.

PANAMA

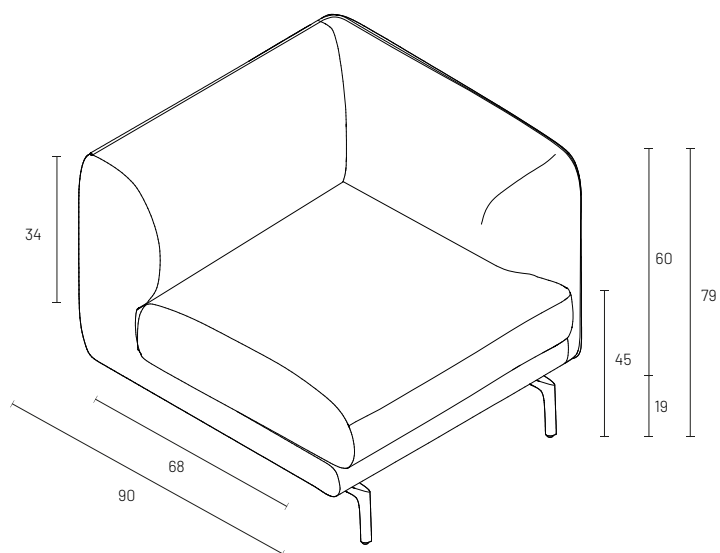
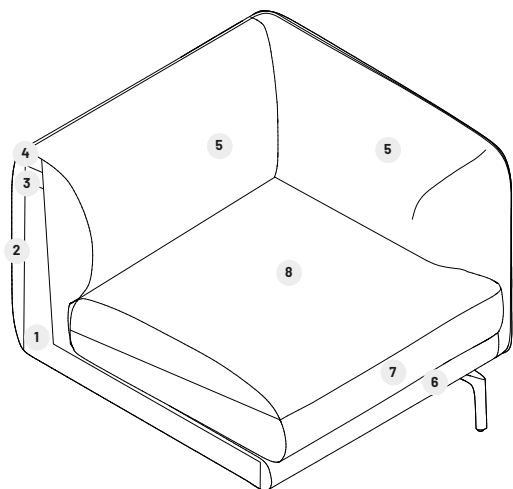

abete massello e multistrato
solid spruce and plywood
sapin massif et contreplaqué
Fichte massiv und kaschierter Stoff
abeto macizo y multicapa

1

poliuretano D21 T
polyurethane D21 T
polyuréthane D21 T
Polyurethan D21 T
poliuretano D21 T

2

poliuretano D40 T
polyurethane D40 T
polyuréthane D40 T
Polyurethan D40 T
poliuretano D40 T

3

poliuretano D21 SH3
polyurethane D21 SH3
polyuréthane D21 SH3
Polyurethan D21 SH3
poliuretano D21 SH3

4

poliuretano D21 SH3 rivestito resinato GR 100 + VELL
polyurethane D21 SH3 covered with GR 100 + VELL resin coating
polyuréthane D21 SH3 revêtu de résiné GR 100 + VELL
Polyurethan D21 SH3 mit Harzbeschichtung GR. 100 + VELL bezogen
poliuretano D21 SH3 recubierto con resina GR 100 + VELL

5

poliuretano D21 T
polyurethane D21 T
polyuréthane D21 T
Polyurethan D21 T
poliuretano D21 T





6

poliuretano D40 PFPFR rivestito resinato GR 150 + VELL
polyurethane D40 PFPFR covered with GR 150 + VELL resin coating
polyuréthane D40 PFPFR revêtu de résiné GR 150 + VELL
Polyurethan D40 PFPFR mit Harzbeschichtung GR. 150 + VELL bezogen
poliuretano D40 PFPFR recubierto con resina GR 150 + VELL

7

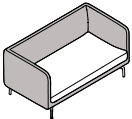
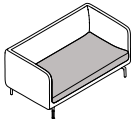
poliuretano D35 olmosoff
polyurethane D35 Olmosoff
polyuréthane D35 olmosoff
Polyurethan D35 Olmosoff
poliuretano D35 Olmosoff

8

	 <p>STRUTTURA E SCHIENALE STRUCTURE AND BACKREST STRUCTURE ET DOSSIER AUFBAU UND RÜCKENLEHNE ESTRUCTURA Y RESPALDO</p>	 <p>SEDUTA SEAT ASSISE SITZFLÄCHE ASIENTO</p>
<p>SFODERABILE REMOVABLE DÉHOUSSABLE ABZIEHBAR DESENFUNDABLE</p>	 <p>fabric simil leather</p>	 <p>fabric simil leather leather</p>
<p>NON SFODERABILE NON REMOVABLE NON DÉHOUSSABLE NICHT ABZIEHBAR NO DESENFUNDABLE</p>	 <p>leather</p>	-

divano 2 posti
2-seat sofa
canapé 2 places
Sofa 2 Sitze
sofa 2 plazos

L W	H H	P D	CODICE CODE	Basic	Start	Extra	Light	Super	K	W	t-cliente com-fabric	ml l.mt.	m ³ kg
--------	--------	--------	----------------	-------	-------	-------	-------	-------	---	---	-------------------------	-------------	----------------------

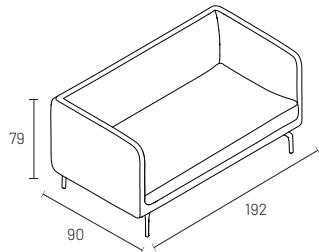

192	79	90	DI01PAAB000	2.640	2.785	2.929	3.026	3.283	4.101	4.846	2.301	7,5	1,23 65
-----	----	----	-------------	-------	-------	-------	-------	-------	-------	-------	-------	-----	------------

divano 2,5 posti
2.5-seat sofa
canapé 2,5 places
Sofa 2,5 Sitze
sofa 2,5 plazos

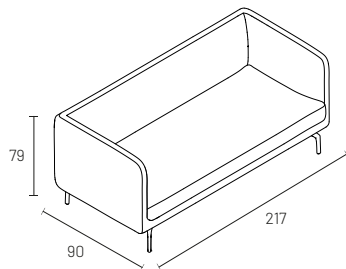

217	79	90	DI01PAAC000	2.710	2.854	2.999	3.095	3.352	4.168	4.913	2.368	8,2	1,4 70
-----	----	----	-------------	-------	-------	-------	-------	-------	-------	-------	-------	-----	-----------

divano 3 posti
3-seat sofa
canapé 3 places
Sofa 3 Sitze
sofa 3 plazos

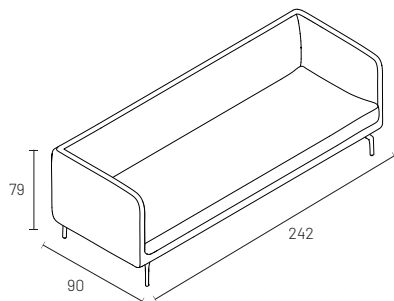

242	79	90	DI01PAAD000	2.780	2.929	3.077	3.176	3.440	4.405	5.195	2.500	9	1,6 75
-----	----	----	-------------	-------	-------	-------	-------	-------	-------	-------	-------	---	-----------

Piedini standard verniciati neri, disponibili in champagne, titanio o laccato opaco con maggiorazione: 25 € cadauno. | Standard feet painted black, also available in champagne, titanium, or matte lacquered with an additional charge of € 25 each. | Pieds standard laqué en noir, disponibles en champagne, titane ou laqué mat avec supplément : 25 € chacun. | Standardfüße schwarz lackiert, erhältlich in Champagne, Titan oder Mattlack gegen Aufpreis von 25 € pro Fuß. | Patas estándar pintados en negro, disponibles en champagne, titanio o lacado mate con un recargo de 25 € cada uno.

PANAMA

moduli | units | modules | module | módulos

pouf
pouf
pouf
pouf
pouf

L W	H H	P D	CODICE CODE	Basic	Start	Extra	Light	Super	K	W	t-cliente com-fabric	ml l.mt.	m ³ kg
--------	--------	--------	----------------	-------	-------	-------	-------	-------	---	---	-------------------------	-------------	----------------------

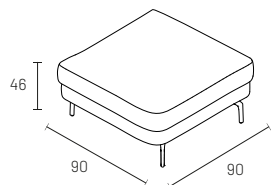

90	46	90	DI01PALA000	894	945	996	1.029	1.120	1.376	1.630	761	3,5	0,3 15
----	----	----	-------------	-----	-----	-----	-------	-------	-------	-------	-----	-----	-----------

poltrona
armchair
fauteuil
Sessel
sillón

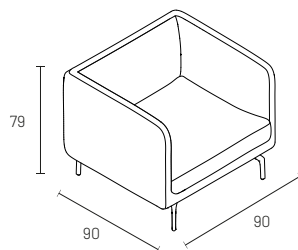

90	79	90	DI01PAMA000	2.085	2.204	2.323	2.402	2.613	3.395	4.027	1.871	5,3	0,6 35
----	----	----	-------------	-------	-------	-------	-------	-------	-------	-------	-------	-----	-----------

Piedini standard verniciati neri, disponibili in champagne, titanio o laccato opaco con maggiorazione: 25 € cadauno. | Standard feet painted black, also available in champagne, titanium, or matte lacquered with an additional charge of € 25 each. | Pieds standard laqué en noir, disponibles en champagne, titane ou laqué mat avec supplément : 25 € chacun. | Standardfüße schwarz lackiert, erhältlich in Champagne, Titan oder Mattlack gegen Aufpreis von 25 € pro Fuß. | Patas estándar pintados en negro, disponibles en champagne, titanio o lacado mate con un recargo de 25 € cada uno.

POLDO



**PIEDINI A | FEET A | PIEDS A | FÜSSE A |
PATAS A**



**PIEDINI B | FEET B | PIEDS B | FÜSSE B |
PATAS B**



STRUTTURA: costruita in abete massello e multistrato e rivestita in poliuretano espanso. Parti secondarie e non strutturali in pannelli di fibre di legno.

SEDUTE, SCHIENALI E BRACCIOLI: imbottiti in poliuretano espanso e rivestiti con un trapuntino in piuma (100%).

PIEDINI: in metallo verniciato nero. Disponibili in champagne, titanio o laccato opaco con maggiorazione: 25€ cadauno. Piedini A di serie, B optional da indicare in fase d'ordine.

VASSOIO: in MDF laccato opaco.

RIVESTIMENTO: sfoderabile in tessuto, parzialmente sfoderabile nella versione in pelle (solo cuscinate).

TESSUTO CLIENTE: il tessuto cliente non comprende le pelli. Per la metratura vedi listino.

STRUCTURE: made of solid spruce and plywood and covered with expanded polyurethane. Secondary and non-structural parts in fibreboard panels.

STRUCTURE, BACKS AND ARMRESTS: padded with expanded polyurethane foam and covered with a 100% down quilt.

FEET: in black varnished metal. Also available in champagne, titanium, or matte lacquered with an additional charge of €25 each feet. Standard feet type A, optional type B to be marked in the order.

TRAY: in MDF matt lacquer.

UPHOLSTERY: removable cover in the fabric version, partially removable in the leather version (cushions only).

CUSTOMER FABRIC: Customer fabric does not include leather. For the required linear metres, see the price list.

STRUCTURE: construite en sapin massif et contreplaqué et rembourrée en polyuréthane expansé. Parties secondaires et non structurelles en panneaux de fibres de bois.

ASSISES, DOSSIERS ET ACCOUDOIRS: rembourrés en polyuréthane expansé et recouverts d'un matelassage en plume (100%).

PIEDS: en métal laqué en noir. Disponibles en champagne, titane ou laqué mat avec supplément : 25 € chacun. Pieds A de série, patins B en option à préciser lors de la commande.

PLATEAU: en MDF laqué mat.

REVÊTEMENT: tissu déhoussable, partiellement déhoussable en version cuir (seulement les coussins).

TISSU CLIENT: le tissu client n'inclut pas les cuirs. Pour le métrage, voir le tarif.

STRUKTUR: Fichte massiv und kaschierter Stoff, mit Polyurethanschaum. Nicht Teile aus Holzfaserverplatten.

SITZFLÄCHEN, RÜCKENLEHNEN UND ARMLEHNEN: Polsterung aus Polyurethanschaum, mit 100 % Außensteppung aus Daunen.

FÜSSE: aus schwarz lackiertem Metall. Auch erhältlich in Champagne, Titan oder Mattlack gegen Aufpreis von 25 € pro Fuß. Serienmäßige Füße Typ A, optional Füße Typ B (bei der Bestellung anzugeben).

TABLETT: aus MDF matt lackiert.

ABDECKUNG: Vollständig abziehbar in der Stoffversion, bei der Lederversion teilweise abnehmbar (nur Kissen).

EIGENSTOFF: Vom Kunden bereitgestellter Stoff umfasst kein Leder. Für den benötigten Stoffverbrauch siehe Preisliste.

ESTRUCTURA: construido en abeto macizo y multicapa y revestido con poliuretano expandido. Partes secundarias y no estructurales en paneles de fibra de madera.

ASIENTOS, RESPALDOS Y BRAZOS: acolchado en poliuretano expandido y revestidos externamente con acolchado de pluma (100%).

PATAS: en metal lacado negro. Disponibles en champagne, titanio o lacado mate con recargo de 25 € cada uno. Estándar pata tipo A, a petición pata B (indicar siempre en el pedido).

BANDEJA: En MDF lacado mate.

REVESTIMIENTO: desenfundable en la versión tejido, parcialmente desenfundable en la versión piel (solo cojines).

TELA CLIENTE: El tejido proporcionado por el cliente no incluye pieles. Para el metraje, consulte la lista de precios.

POLDO

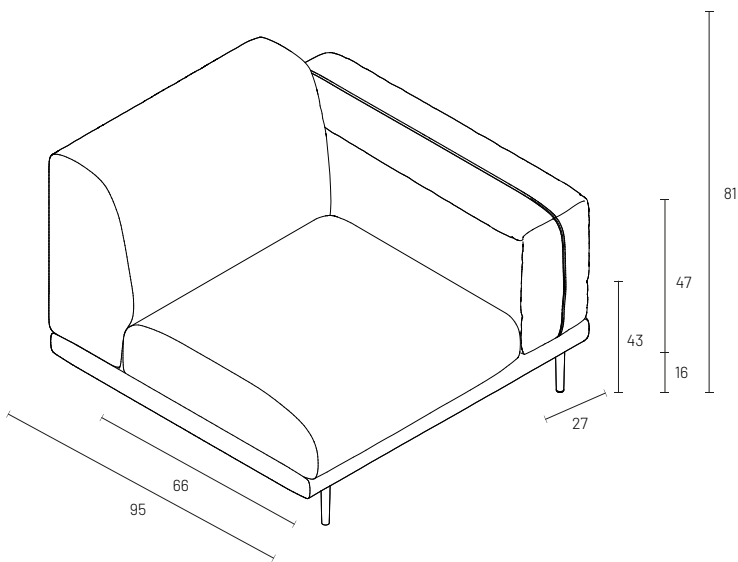
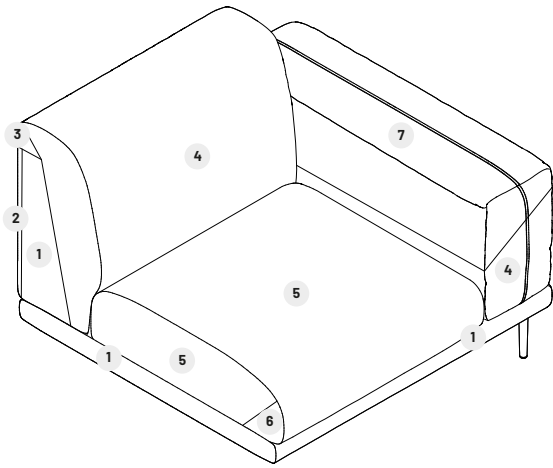

abete massello e multistrato

solid spruce and plywood
sapin massif et contreplaqué
Fichte massiv und kaschierter Stoff
abeto macizo y multicapa

1

poliuretano D21 T
polyurethane D21 T
polyuréthane D21 T
Polyurethan D21 T
poliuretano D21 T

2

poliuretano D40 PK
polyurethane D40 PK
polyuréthane D40 PK
Polyurethan D40 PK
poliuretano D40 PK

3

poliuretano D21 rivestito in piuma telogo
polyurethane D21 covered with down feather padding
polyuréthane D21 revêtu de plume telogo
Polyurethan D21 mit Daunenfüllung bezogen
poliuretano D21 revestido con relleno de pluma de ganso

4

poliuretano D35 PFFR rivestito in piuma telogo
polyurethane D35 PFFR covered with down feather padding
polyuréthane D35 PFFR revêtu de plume telogo
Polyurethan D35 PFFR mit Daunenfüllung bezogen
poliuretano D35 PFFR revestido con relleno de pluma de ganso









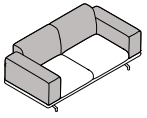

5

poliuretano D40 PK
polyurethane D40 PK
polyuréthane D40 PK
Polyurethan D40 PK
poliuretano D40 PK

6

poliuretano D40 PF rivestito resinato GR 100 + VELL
polyurethane D40 PF covered with GR 100 + VELL resin coating
polyuréthane D40 PF revêtu de résiné GR 100 + VELL
Polyurethan D40 PF mit Harzbeschichtung GR. 100 + VELL bezogen
poliuretano D40 PF recubierto con resina GR 100 + VELL

7

			
	PIANALE BASE PLATEAU PLATTFORM PLATAFORMA	SCHIENALI E BRACCIOLI BACKRESTS AND ARMRESTS DOSSIERS ET ACCOUDOIRS RÜCKENLEHNEN UND ARMLEHNEN RESPALDOS Y REPOSABRAZOS	SEDUTA SEAT ASSISE SITZFLÄCHE ASIENTO
SFODERABILE REMOVABLE DÉHOUSSABLE ABZIEHBAR DESENFUNDABLE	 	  	  
NON SFODERABILE NON REMOVABLE NON DÉHOUSSABLE NICHT ABZIEHBAR NO DESENFUNDABLE		-	-

divano 2 posti
2-seat sofa
canapé 2 places
Sofa 2 Sitze
sofa 2 plazas

L W	H H	P D	CODICE CODE	Basic	Start	Extra	Light	Super	K	W	t-cliente com-fabric	ml l.mt.	m ³ kg
--------	--------	--------	----------------	-------	-------	-------	-------	-------	---	---	-------------------------	-------------	----------------------

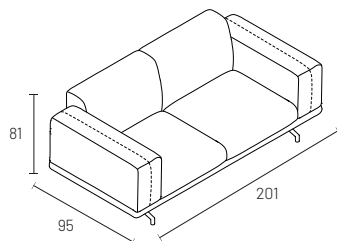

201	81	95	DI01POAB000	3.092	3.232	3.373	3.466	3.715	4.630	5.375	2.830	10,5	1,51 80
-----	----	----	-------------	-------	-------	-------	-------	-------	-------	-------	-------	------	------------

divano 2,5 posti
2.5-seat sofa
canapé 2,5 places
Sofa 2,5 Sitze
sofa 2,5 plazas

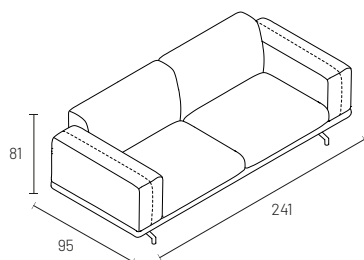

241	81	95	DI01POAC000	3.235	3.375	3.515	3.609	3.858	4.772	5.518	2.972	10,5	1,81 90
-----	----	----	-------------	-------	-------	-------	-------	-------	-------	-------	-------	------	------------

divano 3 posti
3-seat sofa
canapé 3 places
Sofa 3 Sitze
sofa 3 plazas

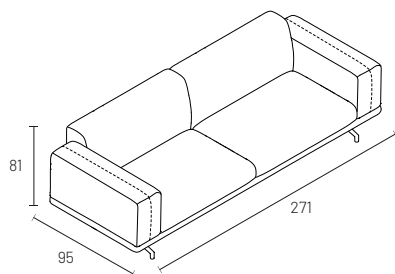

271	81	95	DI01POAD000	3.388	3.537	3.685	3.784	4.048	5.014	5.803	3.108	10,5	2,03 100
-----	----	----	-------------	-------	-------	-------	-------	-------	-------	-------	-------	------	-------------

Piedini standard verniciati neri, disponibili in champagne, titanio o laccato opaco con maggiorazione: 25 € cadauno. | Standard feet painted black, also available in champagne, titanium, or matte lacquered with an additional charge of € 25 each. | Pieds standard laqué en noir, disponibles en champagne, titane ou laqué mat avec supplément : 25 € chacun. | Standardfüße schwarz lackiert, erhältlich in Champagne, Titan oder Mattlack gegen Aufpreis von 25 € pro Fuß. | Patas estándar pintados en negro, disponibles en champagne, titanio o lacado mate con un recargo de 25 € cada uno.

divano 2 posti con vassoio (incluso)
 2-seat sofa with tray (included)
 canapé 2 places avec plateau (inclus)
 Sofa 2 Sitze mit Tablett (inbegriffen)
 sofa 2 plazos con bandeja (incluido)

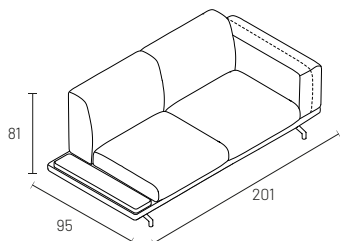

	L W	H H	P D	CODICE CODE	Basic	Start	Extra	Light	Super	K	W	t-cliente com-fabric	ml l.mt.	m ³ kg
dx rh droite re. dcha	201	81	95	DI01POABDVO	3.079	3.212	3.345	3.433	3.669	4.538	5.243	2.834	9	1,3 75
sx lh gauche li. izda	201	81	95	DI01POABSV0	3.079	3.212	3.345	3.433	3.669	4.538	5.243	2.834	9	1,3 75

divano 2,5 posti con vassoio (incluso)
 2.5-seat sofa with tray (included)
 canapé 2,5 places avec plateau (inclus)
 Sofa 2,5 Sitze mit Tablett (inbegriffen)
 sofa 2,5 plazos con bandeja (incluido)

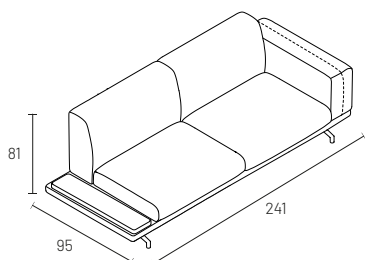

dx rh droite re. dcha	241	81	95	DI01POACDVO	3.222	3.355	3.487	3.576	3.812	4.680	5.386	2.976	9	1,6 82
sx lh gauche li. izda	241	81	95	DI01POACSV0	3.222	3.355	3.487	3.576	3.812	4.680	5.386	2.976	9	1,6 82

divano 3 posti con vassoio (incluso)
 3-seat sofa with tray (included)
 canapé 3 places avec plateau (inclus)
 Sofa 3 Sitze mit Tablett (inbegriffen)
 sofa 3 plazos con bandeja (incluido)

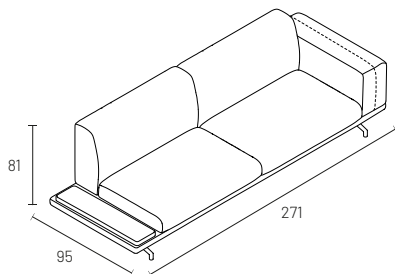

dx rh droite re. dcha	271	81	95	DI01POADDVO	3.375	3.517	3.657	3.751	4.002	4.922	5.671	3.112	9	1,82 90
sx lh gauche li. izda	271	81	95	DI01POADSV0	3.375	3.517	3.657	3.751	4.002	4.922	5.671	3.112	9	1,82 90

Moduli rappresentati sx se non specificato diversamente. | Piedini standard verniciati neri, disponibili in champagne, titanio o laccato opaco con maggiorazione: 25 € cadauno. | Units represented as lh unless otherwise specified. | Standard feet painted black, also available in champagne, titanium, or matte lacquered with an additional charge of € 25 each. | Modules représentés à gauche sauf indication contraire. | Pieds standard laqué en noir, disponibles en champagne, titane ou laqué mat avec supplément : 25 € chacun. | Module links dargestellt, sofern nicht anders angegeben. | Standardfüße schwarz lackiert, erhältlich in Champagne, Titan oder Mattlack gegen Aufpreis von 25 € pro Fuß. | Módulos representados izquierdos, excepto indicación contraria. | Patas estándar pintados en negro, disponibles en champagne, titanio o lacado mate con un recargo de 25 € cada uno.

laterale 2 posti
2-seat side element
latéral 2 places
seitliches Modul 2 Sitze
módulo lateral 2 plazas

L	H	P	CODICE	Basic	Start	Extra	Light	Super	K	W	t-cliente	ml	m³
W	H	D	CODE								com-fabric	l.mt.	kg

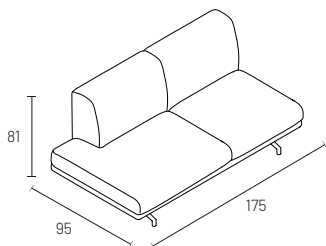

dx rh droite	175	81	95	DI01POBBD00	2.638	2.757	2.876	2.955	3.166	3.948	4.580	2.424	8,5	1,2 65
re. dcha sx lh gauche	175	81	95	DI01POBBS00	2.638	2.757	2.876	2.955	3.166	3.948	4.580	2.424	8,5	1,2 65
li. izda														

laterale 2,5 posti
2.5-seat side element
latéral 2,5 places
seitliches Modul 2,5 Sitze
módulo lateral 2,5 plazas

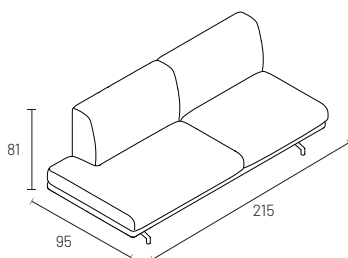

dx rh droite	215	81	95	DI01POBCD00	2.830	2.962	3.094	3.182	3.416	4.280	4.982	2.586	8,5	1,5 72
re. dcha sx lh gauche	215	81	95	DI01POBCS00	2.830	2.962	3.094	3.182	3.416	4.280	4.982	2.586	8,5	1,5 72
li. izda														

laterale 3 posti
3-seat side element
latéral 3 places
seitliches Modul 3 Sitze
módulo lateral 3 plazas

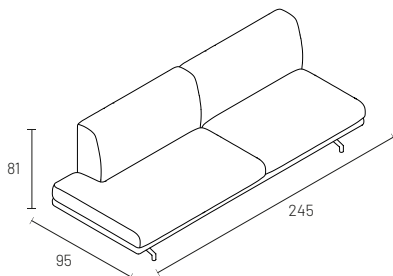

dx rh droite	245	81	95	DI01POBDD00	2.959	3.086	3.213	3.297	3.523	4.356	5.032	2.726	8,5	1,7 80
re. dcha sx lh gauche	245	81	95	DI01POBDS00	2.959	3.086	3.213	3.297	3.523	4.356	5.032	2.726	8,5	1,7 80
li. izda														

Moduli rappresentati sx se non specificato diversamente. | Piedini standard verniciati neri, disponibili in champagne, titanio o laccato opaco con maggiorazione: 25 € cadauno. | Units represented as lh unless otherwise specified. | Standard feet painted black, also available in champagne, titanium, or matte lacquered with an additional charge of € 25 each. | Modules représentés à gauche sauf indication contraire. | Pieds standard laqué en noir, disponibles en champagne, titane ou laqué mat avec supplément : 25 € chacun. | Module links dargestellt, sofern nicht anders angegeben. | Standardfüße schwarz lackiert, erhältlich in Champagne, Titan oder Mattlack gegen Aufpreis von 25 € pro Fuß. | Módulos representados izquierdos, excepto indicación contraria. | Patas estándar pintados en negro, disponibles en champagne, titanio o lacado mate con un recargo de 25 € cada uno.

laterale 2 posti con bracciolo
2-seat side element with armrest
latéral 2 places avec accouoir
seitliches Modul 2 Sitze mit Armlehne
módulo lateral 2 plazas con brazo

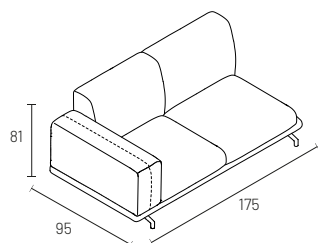

	L W	H H	P D	CODICE CODE	Basic	Start	Extra	Light	Super	K	W	t-cliente com-fabric	ml l.mt.	m³ kg
dx rh droite re. dcha	175	81	95	DI01POBDBO	2.797	2.916	3.035	3.114	3.325	4.107	4.739	2.583	9	1,3 75
sx lh gauche li. izda	175	81	95	DI01POBBSBO	2.797	2.916	3.035	3.114	3.325	4.107	4.739	2.583	9	1,3 75

laterale 2,5 posti con bracciolo
2.5-seat side element with armrest
latéral 2,5 places avec accouoir
seitliches Modul 2,5 Sitze mit Armlehne
módulo lateral 2,5 plazas con brazo

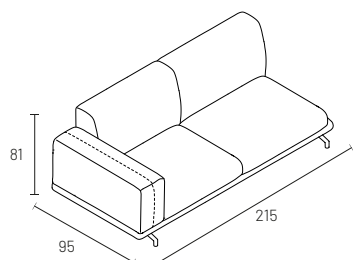

dx rh droite re. dcha	215	81	95	DI01POBCDBO	2.969	3.101	3.233	3.321	3.556	4.419	5.121	2.725	9	1,6 82
sx lh gauche li. izda	215	81	95	DI01POBCSBO	2.969	3.101	3.233	3.321	3.556	4.419	5.121	2.725	9	1,6 82

laterale 3 posti con bracciolo
3-seat side element with armrest
latéral 3 places avec accouoir
seitliches Modul 3 Sitze mit Armlehne
módulo lateral 3 plazas con brazo

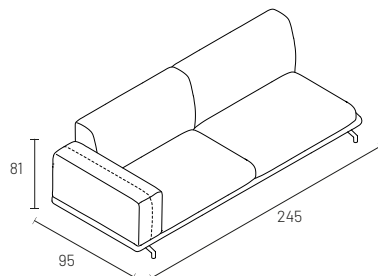

dx rh droite re. dcha	245	81	95	DI01POBDDBO	3.088	3.215	3.342	3.427	3.652	4.485	5.161	2.855	9	1,82 90
sx lh gauche li. izda	245	81	95	DI01POBDSBO	3.088	3.215	3.342	3.427	3.652	4.485	5.161	2.855	9	1,82 90

Moduli rappresentati sx se non specificato diversamente. | Piedini standard verniciati neri, disponibili in champagne, titanio o laccato opaco con maggiorazione: 25 € cadauno. | Units represented as lh unless otherwise specified. | Standard feet painted black, also available in champagne, titanium, or matte lacquered with an additional charge of € 25 each. | Modules représentés à gauche sauf indication contraire. | Pieds standard laqué en noir, disponibles en champagne, titane ou laqué mat avec supplément : 25 € chacun. | Module links dargestellt, sofern nicht anders angegeben. | Standardfüße schwarz lackiert, erhältlich in Champagne, Titan oder Mattlack gegen Aufpreis von 25 € pro Fuß. | Módulos representados izquierdos, excepto indicación contraria. | Patas estándar pintados en negro, disponibles en champagne, titanio o lacado mate con un recargo de 25 € cada uno.

laterale 2 posti con vassoio (incluso)
 2-seat side element with tray (included)
 latéral 2 places avec plateau (inclus)
 seitliches Modul 2 Sitze mit Tablett (inbegriffen)
 módulo lateral 2 plazas con bandeja (incluido)

L	H	P	CODICE	Basic	Start	Extra	Light	Super	K	W	t-cliente	ml	m³
W	H	D	CODE								com-fabric	l.mt.	kg

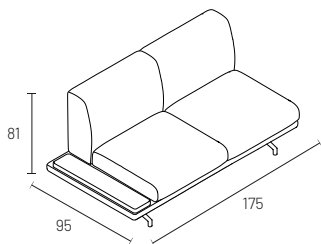

dx rh droite	175	81	95	DI01POBBDVO	2.874	2.993	3.112	3.191	3.402	4.184	4.816	2.660	8,5	1,2 65
re. dcha sx lh gauche	175	81	95	DI01POBBSVO	2.874	2.993	3.112	3.191	3.402	4.184	4.816	2.660	8,5	1,2 65
li. izda														

laterale 2,5 posti con vassoio (incluso)
 2.5-seat side element with tray (included)
 latéral 2,5 places avec plateau (inclus)
 seitliches Modul 2,5 Sitze mit Tablett (inbegriffen)
 módulo lateral 2,5 plazas con bandeja (incluido)

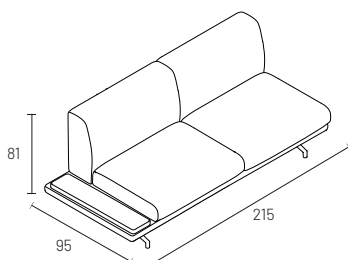

dx rh droite	215	81	95	DI01POBCDVO	3.066	3.198	3.330	3.418	3.652	4.516	5.218	2.822	8,5	1,5 72
re. dcha sx lh gauche	215	81	95	DI01POBCSVO	3.066	3.198	3.330	3.418	3.652	4.516	5.218	2.822	8,5	1,5 72
li. izda														

laterale 3 posti con vassoio (incluso)
 3-seat side element with tray (included)
 latéral 3 places avec plateau (inclus)
 seitliches Modul 3 Sitze mit Tablett (inbegriffen)
 módulo lateral 3 plazas con bandeja (incluido)

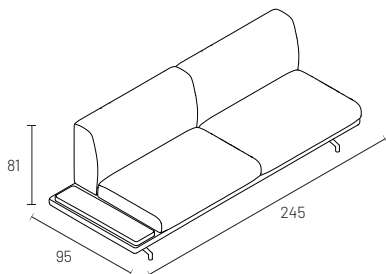

dx rh droite	245	81	95	DI01POBDDVO	3.195	3.322	3.449	3.533	3.759	4.592	5.268	2.962	8,5	1,7 80
re. dcha sx lh gauche	245	81	95	DI01POBDSVO	3.195	3.322	3.449	3.533	3.759	4.592	5.268	2.962	8,5	1,7 80
li. izda														

Moduli rappresentati sx se non specificato diversamente. | Piedini standard verniciati neri, disponibili in champagne, titanio o laccato opaco con maggiorazione: 25 € cadauno. | Units represented as lh unless otherwise specified. | Standard feet painted black, also available in champagne, titanium, or matte lacquered with an additional charge of € 25 each. | Modules représentés à gauche sauf indication contraire. | Pieds standard laqué en noir, disponibles en champagne, titane ou laqué mat avec supplément : 25 € chacun. | Module links dargestellt, sofern nicht anders angegeben. | Standardfüße schwarz lackiert, erhältlich in Champagne, Titan oder Mattlack gegen Aufpreis von 25 € pro Fuß. | Módulos representados izquierdos, excepto indicación contraria. | Patas estándar pintados en negro, disponibles en champagne, titanio o lacado mate con un recargo de 25 € cada uno.

angolo
corner unit
angle
Ecke
ángulo

L	H	P	CODICE	Basic	Start	Extra	Light	Super	K	W	t-cliente	ml	m³
W	H	D	CODE								com-fabric	l.mt.	kg

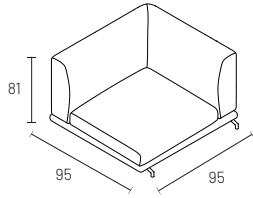

95	81	95	DI01POF0000	1.834	1.909	1.983	2.032	2.164	2.672	3.067	1.719	7,5	0,71 45
----	----	----	-------------	-------	-------	-------	-------	-------	-------	-------	-------	-----	------------

raccordo 45°
45° connecting element
raccord à 45°
45°-Verbindungsstück
conexión de 45°

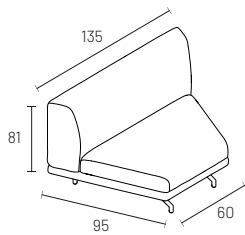

135	81	95	DI01POG0000	2.023	2.122	2.221	2.287	2.463	3.123	3.649	1.852	7,5	0,76 38
-----	----	----	-------------	-------	-------	-------	-------	-------	-------	-------	-------	-----	------------

isola
sectional element
méridienne
chaise longue
chaise longue

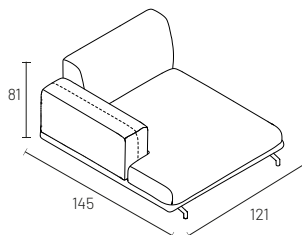

dx														
rh														
droite	121	81	145	DI01POD0D00	2.225	2.323	2.420	2.485	2.658	3.308	3.825	2.058	7,7	1,4 80
re.														
dcha														
sx	121	81	145	DI01POD0S00	2.225	2.323	2.420	2.485	2.658	3.308	3.825	2.058	7,7	1,4 80
ih														
gauche														
li.														
izda														

Moduli rappresentati sx se non specificato diversamente. | Piedini standard verniciati neri, disponibili in champagne, titanio o laccato opaco con maggiorazione: 25 € cadauno. | Units represented as lh unless otherwise specified. | Standard feet painted black, also available in champagne, titanium, or matte lacquered with an additional charge of € 25 each. | Modules représentés à gauche sauf indication contraire. | Pieds standard laqué en noir, disponibles en champagne, titane ou laqué mat avec supplément : 25 € chacun. | Module links dargestellt, sofern nicht anders angegeben. | Standardfüße schwarz lackiert, erhältlich in Champagne, Titan oder Mattlack gegen Aufpreis von 25 € pro Fuß. | Módulos representados izquierdos, excepto indicación contraria. | Patas estándar pintados en negro, disponibles en champagne, titanio o lacado mate con un recargo de 25 € cada uno.

composizione 1 (rappresentata dx)
 composition 1 (rh in the picture)
 composition 1 (illustré à droite)
 Zusammenstellung 1 (rechts dargestellt)
 Composición 1 (representada a la derecha)

L	H	P	CODICE	Basic	Start	Extra	Light	Super	K	W	t-cliente	ml	m³
W	H	D	CODE								com-fabric	l.mt.	kg

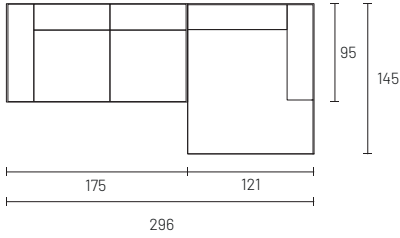

296	81	145	POLDC1	5.022	5.239	5.455	5.599	5.983	7.415	8.564	4.641	16,7	2,7 155
-----	----	-----	--------	-------	-------	-------	-------	-------	-------	-------	-------	------	------------

composizione 2 (rappresentata dx)
 composition 2 (rh in the picture)
 composition 2 (illustré à droite)
 Zusammenstellung 2 (rechts dargestellt)
 Composición 2 (representada a la derecha)

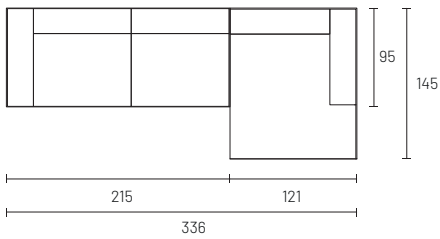

336	81	145	POLDC2	5.194	5.424	5.653	5.806	6.214	7.727	8.946	4.783	16,7	3 162
-----	----	-----	--------	-------	-------	-------	-------	-------	-------	-------	-------	------	----------

composizione 3 (rappresentata dx)
 composition 3 (rh in the picture)
 composition 3 (illustré à droite)
 Zusammenstellung 3 (rechts dargestellt)
 Composición 3 (representada a la derecha)

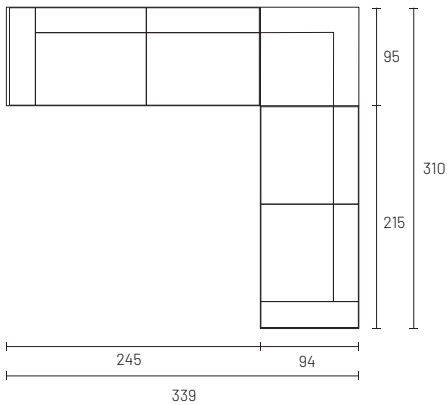

339	81	310	POLDC3	7.891	8.225	8.558	8.780	9.372	11.576	13.349	7.299	25,5	4,13 217
-----	----	-----	--------	-------	-------	-------	-------	-------	--------	--------	-------	------	-------------

composizione 4 (rappresentata dx)
 composition 4 (rh in the picture)
 composition 4 (illustré à droite)
 Zusammenstellung 4 (rechts dargestellt)
 Composición 4 (representada a la derecha)

L W	H H	P D	CODICE CODE	Basic	Start	Extra	Light	Super	K	W	t-cliente com-fabric	ml l.mt.	m³ kg
--------	--------	--------	----------------	-------	-------	-------	-------	-------	---	---	-------------------------	-------------	----------

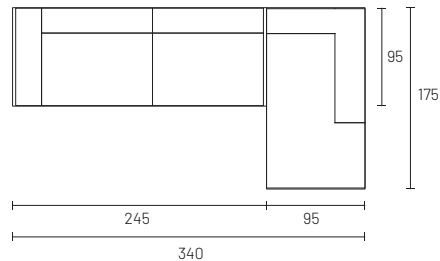

340	81	175	POLDC4	5.885	6.131	6.377	6.541	6.977	8.592	9.900	5.438	19	3,48 178
-----	----	-----	--------	-------	-------	-------	-------	-------	-------	-------	-------	----	-------------

composizione 5 (rappresentata dx)
 composition 5 (rh in the picture)
 composition 5 (illustré à droite)
 Zusammenstellung 5 (rechts dargestellt)
 Composición 5 (representada a la derecha)

492	81	242	POLDC5	7.749	8.094	8.439	8.669	9.281	11.556	13.390	7.131	25	3,78 193
-----	----	-----	--------	-------	-------	-------	-------	-------	--------	--------	-------	----	-------------

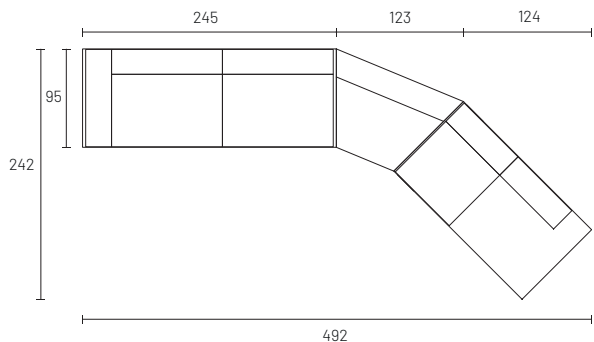

composizione 6 (rappresentata dx)
 composition 6 (rh in the picture)
 composition 6 (illustré à droite)
 Zusammenstellung 6 (rechts dargestellt)
 Composición 6 (representada a la derecha)

422	81	242	POLDC6	7.694	8.031	8.368	8.592	9.190	11.414	13.204	7.095	25	3,26 178
-----	----	-----	--------	-------	-------	-------	-------	-------	--------	--------	-------	----	-------------

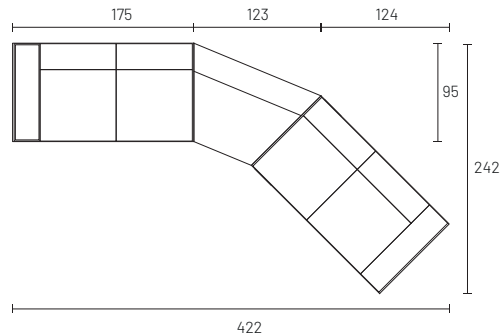

RAGGIO

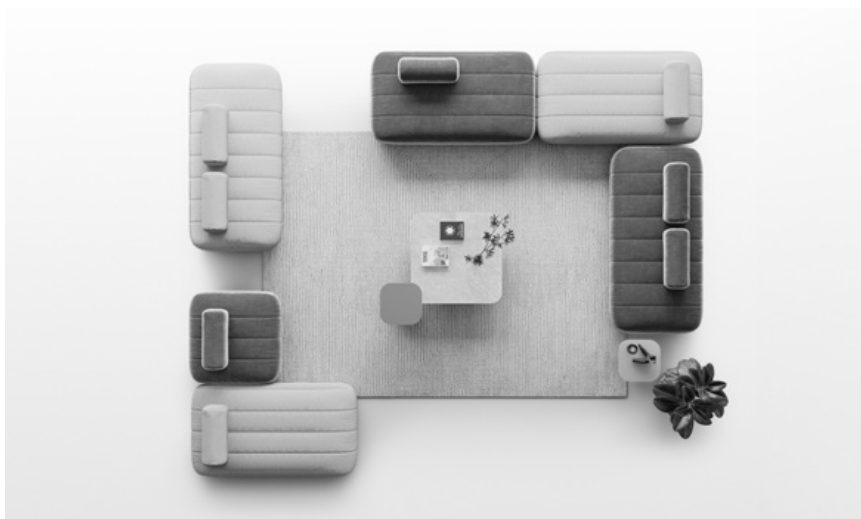

PIEDINI | FEET | PIEDS | FÜSSE | PATAS



STRUTTURA: costruita in abete massello e pannelli di multistrato/particelle legnose e rivestita con lastre di poliuretano. Parti secondarie e non strutturali in pannelli di agglomerato.

SEDUTE: imbottite in poliuretano espanso a densità differenziata, rivestimento vellutino 3 corpi.

SCHIENALI: in poliuretano espanso ad alta densità con reparto per sacche di sabbia in modo da creare peso allo schienale per renderlo stabile (fermo) nella posizione desiderata. Si consiglia l'uso del cuscino/schienale per un maggiore comfort.

RIVESTIMENTO: Non disponibile in Fintapelle vintage/intreccio (Extra) e in Cartagena (Start). Sfoderabile in tessuto.

TESSUTO CLIENTE: il tessuto cliente non comprende le pelli. Per la metratura vedi listino.

STRUCTURE: made of solid spruce and plywood and multi-layer/particleboard panels, covered with polyurethane sheets. Secondary and non-structural parts in fibreboard panels.

SEATS: padded with differentiated density expanded polyurethane foam, velvet coating, 3 pieces.

BACKRESTS: high density expanded polyurethane foam with compartment for sand pockets to keep the backrest steady in the required position. It is recommended to use at least one support cushion for a greater comfort.

UPHOLSTERY: Not available in Fintapelle Vintage/Intreccio (Extra) and Cartagena (Start). Removable cover in the fabric version.

CUSTOMER FABRIC: Customer fabric does not include leather. For the required linear metres, see the price list.

STRUCTURE: construite en sapin massif et panneaux en multiplis/particules de bois et revêtue de plaques de polyuréthane. Parties secondaires et non structurelles en panneaux d'aggloméré.

ASSISES: rembourrés en polyuréthane expansé à densité différenciée, revêtement velouté 3 parties.

DOSSIERS: en polyuréthane expansé à haute densité avec compartiment pour sacs de sable afin de créer du poids dans dossier pour le maintenir stable (immobile) dans la position souhaitée. Il est conseillé d'utiliser le coussin/dossier pour un confort accru.

REVÊTEMENT: Non disponible dans Fintapelle vintage/Intreccio (catégorie Extra) et dans Cartagena (catégorie Start). Tissu déhoussable.

TISSU CLIENT: le tissu client n'inclut pas les cuirs. Pour le métrage, voir le tarif.

STRUKTUR: Fichte massiv und Sperrholz-/Holzspanplatten und mit Polyurethanplatten verkleidet. Nicht tragende Teile aus Spanplatte.

SITZFLÄCHEN: Polsterung aus Polyurethanschaum mit unterschiedlicher Dichte, Bezug aus Samtstoff, 3-teilig.

RÜCKENLEHNEN: in Polyurethanschaum mit hoher Dichte, mit Taschen für Sandsacks, um der Rückenlehne Gewicht zu geben und sie fest in der gewünschten Stelle zu halten. Es wird empfohlen, mindestens 1 Rückenkissen für jede Rückenlehne zu verwenden.

ABDECKUNG: Nicht verfügbar im Fintapelle Vintage/Intreccio (Extra) und im Cartagena (Start). Vollständig abziehbar in der Stoffversion.

EIGENSTOFF: Vom Kunden bereitgestellter Stoff umfasst kein Leder. Für den benötigten Stoffverbrauch siehe Preisliste.

ESTRUCTURA: construida en abeto macizo y paneles de multicapa / partículas de madera y revestida con poliuretano expandido. Partes secundarias y no estructurales en paneles aglomerados.

ASIENTOS: acolchado en poliuretano expandido de densidad diferenciada, revestimiento aterciopelado de 3 cuerpos.

RESPALDOS: en poliuretano expandido de alta densidad con espacio para bolsos de arena que pesan sobre el respaldo manteniéndolo estable en su posición. Se aconseja utilizar por lo menos un cojín de apoyo para cada respaldo.

REVESTIMIENTO: No disponible en Fintapelle Vintage/Intreccio (Extra) ni en Cartagena (Start). Desenfundable en la versión tejido.

TELA CLIENTE: El tejido proporcionado por el cliente no incluye pieles. Para el metraje, consulte la lista de precios.

RAGGIO

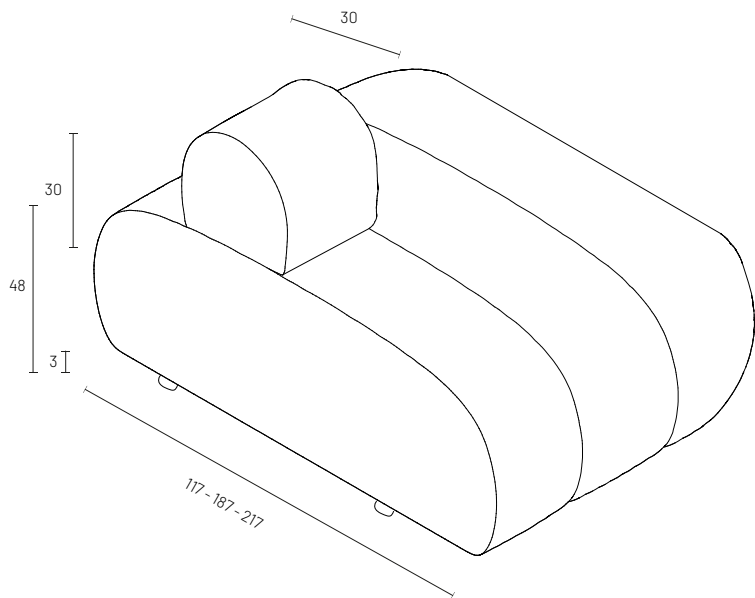
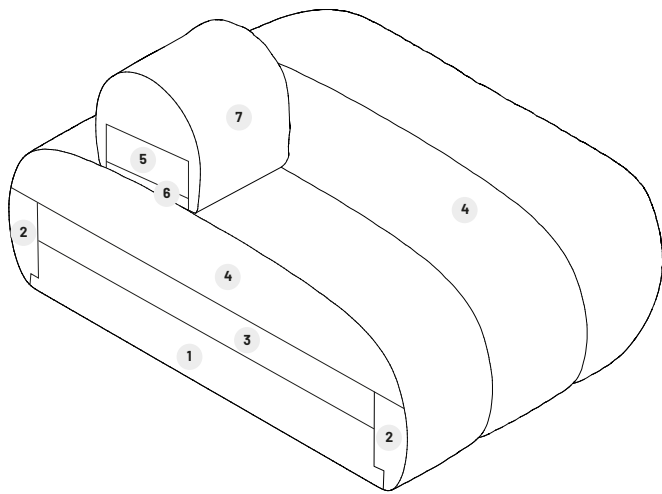

1
abete massello e multistrato
 solid spruce and plywood
 sapin massif et contreplaqué
 Fichte massiv und kaschierter Stoff
 abeto macizo y multicapa

2
poliuretano D25 SM
 polyurethane D25 SM
 polyuréthane D25 SM
 Polyurethan D25 SM
 poliuretano D25 SM



3
poliuretano D32 ALX
 polyurethane D32 ALX
 polyuréthane D32 ALX
 Polyurethan D32 ALX
 poliuretano D32 ALX

4
poliuretano D35 olmosoff rivestito con resinato GR 150 + VELL
 polyurethane D35 Olmosoff covered with GR 150 + VELL resin coating
 polyuréthane D35 olmosoff revêtu de résiné GR 150 + VELL
 Polyurethan D35 Olmosoff mit GR 150 + VELL Harzbeschichtung bezogen
 poliuretano D35 Olmosoff revestido con recubrimiento de resina GR 150 + VELL

5
inserto in sabbia
 sand insert
 insert en sable
 Sand-Einsatz
 inserto de arena

6
poliuretano D40 T
 polyurethane D40 T
 polyuréthane D40 T
 Polyurethan D40 T
 poliuretano D40 T

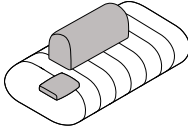
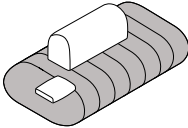
7
poliuretano D25 SM
 polyurethane D25 SM
 polyuréthane D25 SM
 Polyurethan D25 SM
 poliuretano D25 SM

		
	SCHIENALE E BRACCIOLO BACKREST AND ARMREST DOSSIER ET ACCOUDOIR RÜCKENLEHNE UND ARMLEHNE RESPALDO Y BRAZO	SEDUTA SEAT ASSISE SITZFLÄCHE ASIENTO
SFODERABILE REMOVABLE DÉHOUSSABLE ABZIEHBAR DESENFUNDABLE		
NON SFODERABILE NON REMOVABLE NON DÉHOUSSABLE NICHT ABZIEHBAR NO DESENFUNDABLE	-	-

RAGGIO

moduli | units | modules | module | módulos

modulo 1 posto
1-seat element
module 1 place
modul 1 Sitz
módulo 1 plazo

L W	H H	P D	CODICE CODE	Basic	Start	Extra	Light	Super	t-cliente com-fabric	ml l.mt.	m ³ kg
--------	--------	--------	----------------	-------	-------	-------	-------	-------	-------------------------	-------------	----------------------

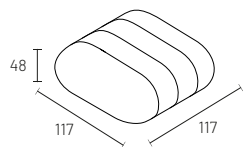

117	48	117	DI01RAAA000	1.269	1.343	1.417	1.467	1.599	1.153	4,5	0,66 32
-----	----	-----	-------------	-------	-------	-------	-------	-------	-------	-----	------------

modulo 2 posti
2-seat element
module 2 places
modul 2 Sitze
módulo 2 plazos

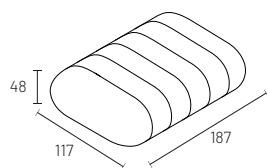

187	48	117	DI01RAAB000	1.688	1.779	1.870	1.930	2.091	1.536	6,5	1,05 41
-----	----	-----	-------------	-------	-------	-------	-------	-------	-------	-----	------------

modulo 2,5 posti
2.5-seat element
module 2,5 places
modul 2,5 Sitze
módulo 2,5 plazos

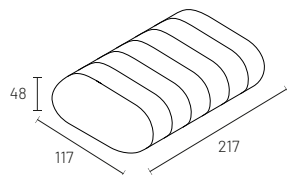

217	48	117	DI01RAAC000	1.863	1.970	2.078	2.149	2.340	1.674	6,5	1,25 52
-----	----	-----	-------------	-------	-------	-------	-------	-------	-------	-----	------------

RAGGIO

moduli | units | modules | module | módulos

modulo 3 posti
3-seat element
module 3 places
modul 3 Sitze
módulo 3 plazas

L W	H H	P D	CODICE CODE	Basic	Start	Extra	Light	Super	t-cliente com-fabric	ml l.mt.	m ³ kg
--------	--------	--------	----------------	-------	-------	-------	-------	-------	-------------------------	-------------	----------------------

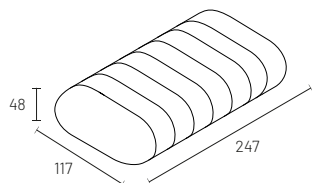

247	48	117	DI01RAAD000	2.100	2.224	2.347	2.430	2.650	1.874	6,5	1,4 64
-----	----	-----	-------------	-------	-------	-------	-------	-------	-------	-----	-----------

chaise longue small
small chaise longue
petite chaise longue
kleine chaise longue
pequeña chaise longue

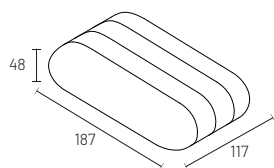

117	48	187	DI01RAIA000	1.688	1.779	1.870	1.930	2.091	1.536	6	1,05 41
-----	----	-----	-------------	-------	-------	-------	-------	-------	-------	---	------------

chaise longue medium
medium chaise longue
chaise longue moyenne
mittlere chaise longue
chaise longue media

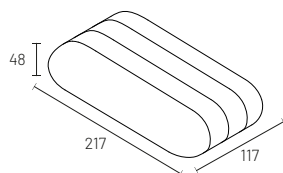

117	48	217	DI01RAIB000	1.863	1.970	2.078	2.149	2.340	1.674	6,6	1,25 52
-----	----	-----	-------------	-------	-------	-------	-------	-------	-------	-----	------------

RAGGIO

moduli | units | modules | module | módulos

chaise longue large
 large chaise longue
 chaise longue grande
 große chaise longue
 chaise longue grande

L W	H H	P D	CODICE CODE	Basic	Start	Extra	Light	Super	t-cliente com-fabric	ml l.mt.	m ³ kg
--------	--------	--------	----------------	-------	-------	-------	-------	-------	-------------------------	-------------	----------------------

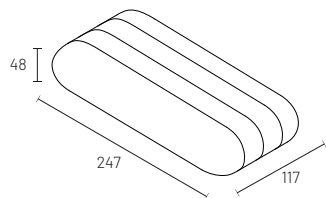

117	48	247	DI01RAIC000	2.100	2.224	2.347	2.430	2.650	1.874	7,2	1,4 64
-----	----	-----	-------------	-------	-------	-------	-------	-------	-------	-----	-----------

schienale piccolo
 small backrest
 dossier petit
 kleine Rückenlehne
 respaldo pequeño

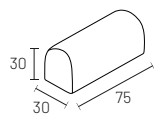

75	30	30	DI01RAXA00S	360	377	393	404	434	324	1,4	0,09 7
----	----	----	-------------	-----	-----	-----	-----	-----	-----	-----	-----------

schienale grande
 large backrest
 dossier grand
 große Rückenlehne
 respaldo grande

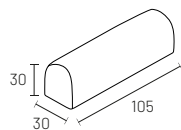

105	30	30	DI01RAXC00S	435	460	484	501	545	380	1,7	1 9
-----	----	----	-------------	-----	-----	-----	-----	-----	-----	-----	--------

RAGGIO

moduli | units | modules | module | módulos

bracciolo
armrest
accoudoir
Armlehne
brazo

L W	H H	P D	CODICE CODE	Basic	Start	Extra	Light	Super	t-cliente com-fabric	ml l.mt.	m ³ kg
--------	--------	--------	----------------	-------	-------	-------	-------	-------	-------------------------	-------------	----------------------

30	13	48	DI01RAXA0B0	163	183	202	216	251	119	1,2	0,03 3
----	----	----	-------------	-----	-----	-----	-----	-----	-----	-----	-----------

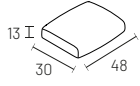

composizione 1 (rappresentata dx)
 composition 1 (rh in the picture)
 composition 1 (illustré à droite)
 Zusammenstellung 1 (rechts dargestellt)
 Composición 1 (representada a la derecha)

L W	H H	P D	CODICE CODE	Basic	Start	Extra	Light	Super	t-cliente com-fabric	ml l.mt.	m ³ kg
--------	--------	--------	----------------	-------	-------	-------	-------	-------	-------------------------	-------------	----------------------

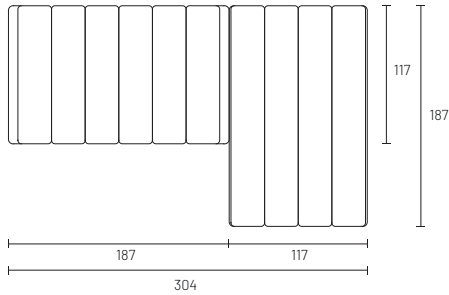

304	48	187	RAGGC1	3.376	3.558	3.740	3.860	4.182	3.072	12,5	2,1 82
-----	----	-----	--------	-------	-------	-------	-------	-------	-------	------	-----------

composizione 2 (rappresentata dx)
 composition 2 (rh in the picture)
 composition 2 (illustré à droite)
 Zusammenstellung 2 (rechts dargestellt)
 Composición 2 (representada a la derecha)

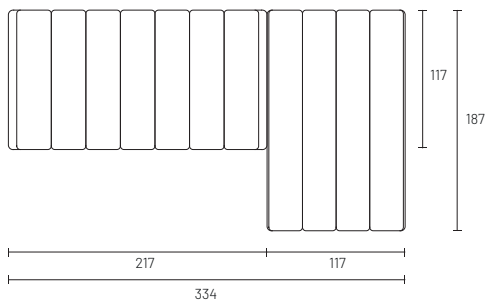

334	48	187	RAGGC2	3.551	3.749	3.948	4.079	4.431	3.210	12,5	2,3 93
-----	----	-----	--------	-------	-------	-------	-------	-------	-------	------	-----------

composizione 3 (rappresentata dx)
 composition 3 (rh in the picture)
 composition 3 (illustré à droite)
 Zusammenstellung 3 (rechts dargestellt)
 Composición 3 (representada a la derecha)

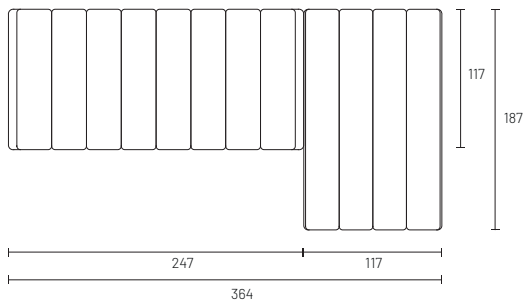

364	48	187	RAGGC3	3.788	4.003	4.217	4.360	4.741	3.410	12,5	2,45 105
-----	----	-----	--------	-------	-------	-------	-------	-------	-------	------	-------------

composizione 4
 composition 4
 composition 4
 Zusammenstellung 4
 Composición 4

L W	H H	P D	CODICE CODE	Basic	Start	Extra	Light	Super	t-cliente com-fabric	ml l.mt.	m ³ kg
--------	--------	--------	----------------	-------	-------	-------	-------	-------	-------------------------	-------------	----------------------

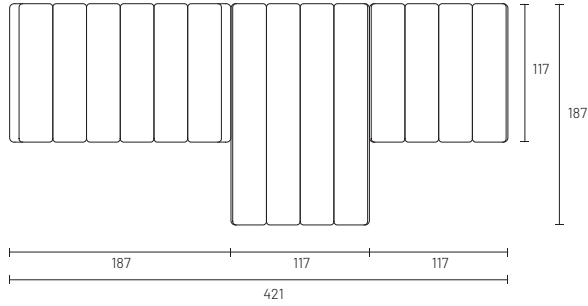

421	48	187	RAGGC4	4.645	4.901	5.157	5.327	5.781	4.225	17	2.76 114
-----	----	-----	--------	-------	-------	-------	-------	-------	-------	----	-------------

SETTANTA



PIEDINI | FEET | PIEDS | FÜSSE | PATAS



STRUTTURA: costruita in abete massello e multistrato e rivestita in poliuretano espanso. Parti secondarie e non strutturali in pannelli di fibre di legno.

SEDUTE, SCHIENALI E BRACCIOLI: imbottiti in piuma d'oca e fiocco.

GUSCIO: anima in lamiera in ferro rivestita in cuoio o ecopelle. Guscio in cuoio con maggiorazione.

PIEDINI: in metallo verniciato nero. Disponibili in champagne, titanio o laccato opaco con maggiorazione: 25€ cadauno.

RIVESTIMENTO: sfoderabile in tessuto, parzialmente sfoderabile nella versione in pelle (solo cuscinate).

TESSUTO CLIENTE: il tessuto cliente non comprende le pelli. Per la metratura vedi listino.

STRUCTURE: made of solid spruce and plywood and covered with expanded polyurethane. Secondary and non-structural parts in fibreboard panels.

STRUCTURE, BACKS AND ARMRESTS: padded with goose down and fiberfill.

SHELL: iron sheet core covered in hard leather or faux leather. Shell in hard leather with surcharge.

FEET: in black varnished metal. Also available in champagne, titanium, or matte lacquered with an additional charge of €25 each feet.

UPHOLSTERY: removable cover in the fabric version, partially removable in the leather version (cushions only).

CUSTOMER FABRIC: Customer fabric does not include leather. For the required linear metres, see the price list.

STRUCTURE: construite en sapin massif et contreplaqué et rembourrée en polyuréthane expansé. Parties secondaires et non structurelles en panneaux de fibres de bois.

ASSISES, DOSSIERS ET ACCOUDOIRS: rembourrés en plume d'oie et flocon.

COQUE: âme en tôle de fer recouverte de cuir ou simili cuir. Coque de cuir avec supplément de prix.

PIEDS: en métal laqué en noir. Disponibles en champagne, titane ou laqué mat avec supplément : 25 € chacun.

REVÊTEMENT: tissu déhoussable, partiellement déhoussable en version cuir (seulement les coussins).

TISSU CLIENT: le tissu client n'inclut pas les cuirs. Pour le métrage, voir le tarif.

STRUKTUR: Fichte massiv und kaschierter Stoff, mit Polyurethanschäum. Nicht Teile aus Holzfasernplatten.

SITZFLÄCHEN, RÜCKENLEHNEN UND ARMLEHNEN: gepolstert aus Gänsedaunen und Schleife.

AUSSENSCHALE: Kern aus Eisenblech, bezogen mit Hartleder oder Kunstleder. Aussenschale mit Hartleder gegen Aufpreis.

FÜSSE: aus schwarz lackiertem Metall. Erhältlich auch in Champagne, Titan oder Mattlack gegen Aufpreis von 25 € pro Fuß.

ABDECKUNG: Vollständig abziehbar in der Stoffversion, bei der Lederversion teilweise abnehmbar (nur Kissen).

EIGENSTOFF: Vom Kunden bereitgestellter Stoff umfasst kein Leder. Für den benötigten Stoffverbrauch siehe Preisliste.

ESTRUCTURA: construido en abeto macizo y multicapa y revestido con poliuretano expandido. Partes secundarias y no estructurales en paneles de fibra de madera.

ASIENTOS, RESPALDOS Y BRAZOS: acolchados con pluma de oca y copo.

CARCASA: núcleo en chapa de hierro revestido en cuero o ecopiel. Carcasa disponible en cuero con regargo.

PATAS: en metal lacado negro. Disponibles en champagne, titanio o lacado mate con recargo de 25 € cada uno.

REVESTIMIENTO: desenfundable en la versión tejido, parcialmente desenfundable en la versión piel (solo cojines).

TELA CLIENTE: El tejido proporcionado por el cliente no incluye pieles. Para el metraje, consulte la lista de precios.

SETTANTA

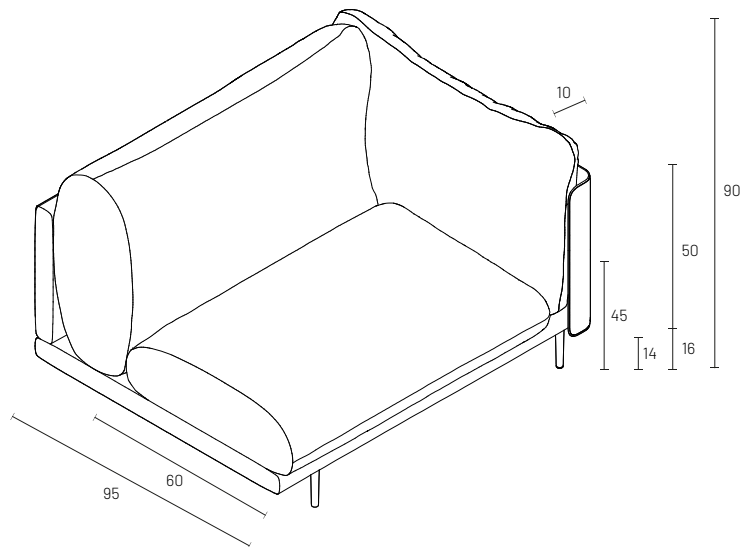
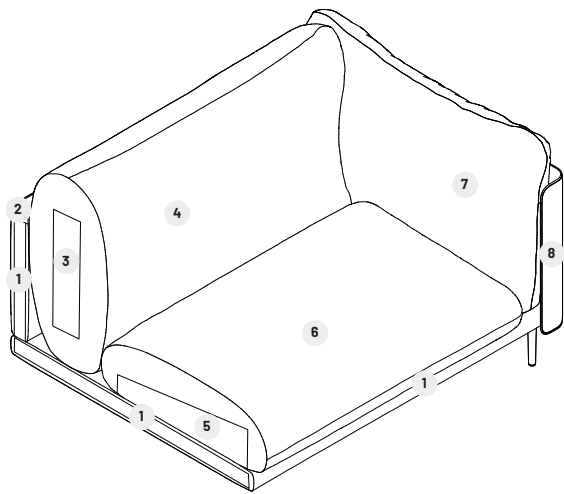

1 abete massello e multistrato rivestito in accoppiato grigio 8 mm
solid spruce and plywood covered with 8 mm grey laminated fabric
sapin massif et contreplaqué revêtu de doublage gris 8 mm
Fichte massiv und kaschierter Stoff verkleidet mit kaschierter Stoff grau 8 mm
abeto macizo y multicapa revestida con material grau 8 mm acoplado

2 poliuretano D40 T
polyurethane D40 T
polyuréthane D40 T
Polyurethan D40 T
poliuretano D40 T

3 poliuretano D18 SS
polyurethane D18 SS
polyuréthane D18 SS
Polyurethan D18 SS
poliuretano D18 SS

4 piuma d'oca e fiocco
goose down and fiberfill
plume d'oie et flocon
Gänsefeder und Schleife
pluma de ganso y lazo

5 poliuretano D35 PF-FR
polyurethane D35 PF-FR
polyuréthane D35 PF-FR
Polyurethan D35 PF-FR
poliuretano D35 PF-FR

6 piuma d'oca e fiocco
goose down and fiberfill
plume d'oie et flocon
Gänsefeder und Schleife
pluma de ganso y lazo

7 fibra di poliestere D25 PSE
D25 PSE polyester fiber
fibre de polyester D25 PSE
Polyesterfaser D25 PSE
fibra de poliéster D25 PSE

8 anima in lamiera in ferro rivestita in cuoio o ecopelle.
iron sheet core covered in hard leather or faux leather
âme en tôle de fer recouverte de cuir ou simili cuir.
Kern aus Eisenblech, bezogen mit Hartleder oder Kunstleder.
núcleo en chapa de hierro revestido en cuero o ecopiel.

	 PIANALE E GUSCIO BASE AND SHELL PLATEAU ET COQUE PLATTFORM UND AUSSENSCHALE PLATAFORMA Y CARCASA	 SCHIENALI E BRACCIOLI BACKRESTS AND ARMRESTS DOSSIERS ET ACCOUDOIRS RÜCKENLEHNEN UND ARMLEHNEN RESPALDOS Y REPOSABRAZOS	 SEDUTA SEAT ASSISE SITZFLÄCHE ASIENTO
SFODERABILE REMOVABLE DÉHOUSSABLE ABZIEHBAR DESENFUNDABLE	-	 fabric simili leather leather	 fabric simili leather leather
NON SFODERABILE NON REMOVABLE NON DÉHOUSSABLE NICHT ABZIEHBAR NO DESENFUNDABLE	 fabric simili leather leather	-	-

SETTANTA

moduli | units | modules | module | módulos

divano 2 posti
2-seat sofa
canapé 2 places
Sofa 2 Sitze
sofa 2 plazos

L W	H H	P D	CODICE CODE	Basic	Start	Extra	Light	Super	K	W	t-cliente com-fabric	ml l.mt.	m ³ kg
--------	--------	--------	----------------	-------	-------	-------	-------	-------	---	---	-------------------------	-------------	----------------------

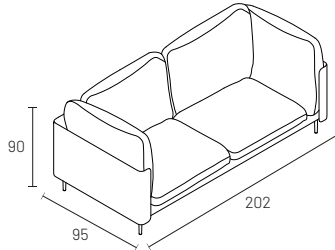

202	90	95	DI01SEAB000	4.098	4.316	4.533	4.678	5.065	7.361	8.633	3.615	14,5	1,62 79
-----	----	----	-------------	-------	-------	-------	-------	-------	-------	-------	-------	------	------------

maggiorazione per guscio in cuoio: 296 € cadauno
Surcharge for hard leather shell: 296 € each
Supplément pour coque de cuir: 296 € chacun
Aufpreis für Aussenschale mit Hartleder: 296 € jeder Aussenschale
Recargo para carcasa en cuero: 296 € cada uno

divano 2,5 posti
2.5-seat sofa
canapé 2,5 places
Sofa 2,5 Sitze
sofa 2,5 plazos

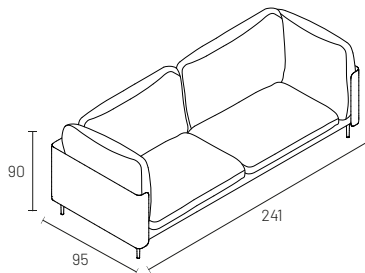

241	90	95	DI01SEAC000	4.364	4.581	4.799	4.944	5.330	7.653	8.925	3.880	14,5	1,94 84
-----	----	----	-------------	-------	-------	-------	-------	-------	-------	-------	-------	------	------------

maggiorazione per guscio in cuoio: 296 € cadauno
Surcharge for hard leather shell: 296 € each
Supplément pour coque de cuir: 296 € chacun
Aufpreis für Aussenschale mit Hartleder: 296 € jeder Aussenschale
Recargo para carcasa en cuero: 296 € cada uno

divano 3 posti
3-seat sofa
canapé 3 places
Sofa 3 Sitze
sofa 3 plazos

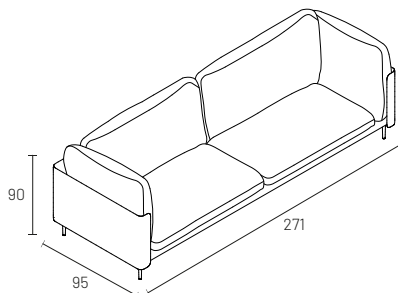

271	90	95	DI01SEAD000	4.580	4.797	5.015	5.160	5.546	7.891	9.163	4.096	14,5	2,18 89
-----	----	----	-------------	-------	-------	-------	-------	-------	-------	-------	-------	------	------------

maggiorazione per guscio in cuoio: 296 € cadauno
Surcharge for hard leather shell: 296 € each
Supplément pour coque de cuir: 296 € chacun
Aufpreis für Aussenschale mit Hartleder: 296 € jeder Aussenschale
Recargo para carcasa en cuero: 296 € cada uno

Piedini standard verniciati neri, disponibili in champagne, titanio o laccato opaco con maggiorazione: 25 € cadauno. | Standard feet painted black, also available in champagne, titanium, or matte lacquered with an additional charge of € 25 each. | Pieds standard laqué en noir, disponibles en champagne, titane ou laqué mat avec supplément : 25 € chacun. | Standardfüße schwarz lackiert, erhältlich in Champagne, Titan oder Mattlack gegen Aufpreis von 25 € pro Fuß. | Patas estándar pintados en negro, disponibles en champagne, titanio o lacado mate con un recargo de 25 € cada uno.

laterale 2 posti

2-seat side element
latéral 2 places
seitliches Modul 2 Sitze
módulo lateral 2 plazas

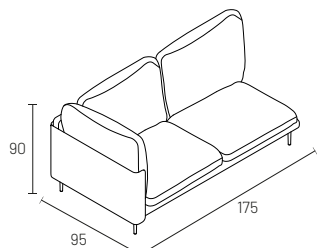

	L W	H H	P D	CODICE CODE	Basic	Start	Extra	Light	Super	K	W	t-cliente com-fabric	ml l.mt.	m ³ kg
dx rh droite re. dcha	175	90	95	DI01SEBBD00	3.337	3.540	3.742	3.877	4.237	6.219	7.405	2.887	13,5	1,42 66
sx lh gauche li. izda	175	90	95	DI01SEBBS00	3.337	3.540	3.742	3.877	4.237	6.219	7.405	2.887	13,5	1,42 66

maggiorazione per guscio in cuoio: 296 €

Surcharge for hard leather shell: 296 €
Supplément pour coque de cuir: 296 €
Aufpreis für Aussenschale mit Hartleder: 296 €
Recargo para carcasa en cuero: 296 €

laterale 2,5 posti

2.5-seat side element
latéral 2,5 places
seitliches Modul 2,5 Sitze
módulo lateral 2,5 plazas

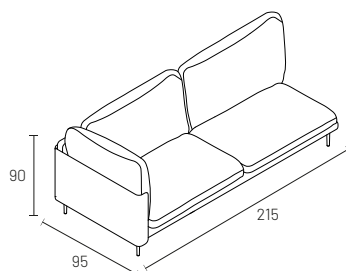

	L W	H H	P D	CODICE CODE	Basic	Start	Extra	Light	Super	K	W	t-cliente com-fabric	ml l.mt.	m ³ kg
dx rh droite re. dcha	215	90	95	DI01SEBCD00	3.624	3.827	4.029	4.164	4.524	6.535	7.721	3.174	13,5	1,74 72
sx lh gauche li. izda	215	90	95	DI01SEBCS00	3.624	3.827	4.029	4.164	4.524	6.535	7.721	3.174	13,5	1,74 72

maggiorazione per guscio in cuoio: 296 €

Surcharge for hard leather shell: 296 €
Supplément pour coque de cuir: 296 €
Aufpreis für Aussenschale mit Hartleder: 296 €
Recargo para carcasa en cuero: 296 €

laterale 3 posti

3-seat side element
latéral 3 places
seitliches Modul 3 Sitze
módulo lateral 3 plazas

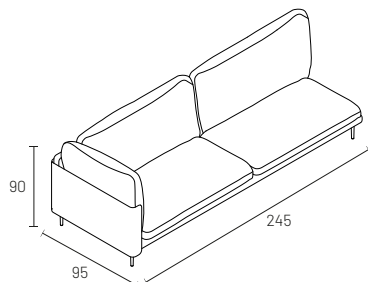

	L W	H H	P D	CODICE CODE	Basic	Start	Extra	Light	Super	K	W	t-cliente com-fabric	ml l.mt.	m ³ kg
dx rh droite re. dcha	245	90	95	DI01SEBDD00	3.826	4.028	4.231	4.366	4.726	6.757	7.942	3.376	13,5	1,99 77
sx lh gauche li. izda	245	90	95	DI01SEBDS00	3.826	4.028	4.231	4.366	4.726	6.757	7.942	3.376	13,5	1,99 77

maggiorazione per guscio in cuoio: 296 €

Surcharge for hard leather shell: 296 €
Supplément pour coque de cuir: 296 €
Aufpreis für Aussenschale mit Hartleder: 296 €
Recargo para carcasa en cuero: 296 €

Moduli rappresentati sx se non specificato diversamente. | Piedini standard verniciati neri, disponibili in champagne, titanio o laccato opaco con maggiorazione: 25 € cadauno. | Units represented as lh unless otherwise specified. | Standard feet painted black, also available in champagne, titanium, or matte lacquered with an additional charge of € 25 each. | Modules représentés à gauche sauf indication contraire. | Pieds standard laqué en noir, disponibles en champagne, titane ou laqué mat avec supplément : 25 € chacun. | Module links dargestellt, sofern nicht anders angegeben. | Standardfüße schwarz lackiert, erhältlich in Champagne, Titan oder Mattlack gegen Aufpreis von 25 € pro Fuß. | Módulos representados izquierdos, excepto indicación contraria. | Patas estándar pintados en negro, disponibles en champagne, titanio o lacado mate con un recargo de 25 € cada uno.

SETTANTA

moduli | units | modules | module | módulos

angolo
corner unit
angle
Ecke
ángulo

L	H	P	CODICE	Basic	Start	Extra	Light	Super	K	W	t-cliente	ml	m ²
W	H	D	CODE								com-fabric	l.mt.	kg

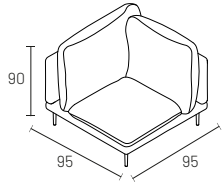

95	90	95	DI01SEFB000	1.855	2.131	2.222	2.283	2.444	2.778	3.540	1.839	9,5	0,76 40
----	----	----	-------------	-------	-------	-------	-------	-------	-------	-------	-------	-----	------------

isola
sectional element
mériidienne
chaise longue
chaise longue

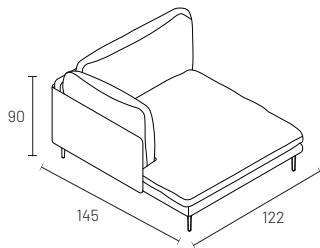

dx rh droite	122	90	145	DI01SED0D00	3.124	3.236	3.349	3.424	3.624	4.528	5.126	2.874	10	1,48 60
re. dcha sx lh gauche	122	90	145	DI01SED0S00	3.124	3.236	3.349	3.424	3.624	4.528	5.126	2.874	10	1,48 60
ii. izda														

maggiorazione per guscio in cuoio: 368 €
Surcharge for hard leather shell: 368 €
Supplément pour coque de cuir: 368 €
Aufpreis für Aussenschale mit Hartleder: 368 €
Recargo para carcasa en cuero: 368 €

pouf
pouf
pouf
pouf
pouf

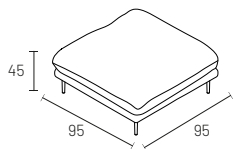

95	45	95	DI01SELA000	1.064	1.113	1.163	1.196	1.284	1.490	1.902	954	4	0,38 20
----	----	----	-------------	-------	-------	-------	-------	-------	-------	-------	-----	---	------------

Moduli rappresentati sx se non specificato diversamente. | Piedini standard verniciati neri, disponibili in champagne, titanio o laccato opaco con maggiorazione: 25 € cadauno. | Units represented as lh unless otherwise specified. | Standard feet painted black, also available in champagne, titanium, or matte lacquered with an additional charge of € 25 each. | Modules représentés à gauche sauf indication contraire. | Pieds standard laqué en noir, disponibles en champagne, titane ou laqué mat avec supplément : 25 € chacun. | Module links dargestellt, sofern nicht anders angegeben. | Standardfüße schwarz lackiert, erhältlich in Champagne, Titan oder Mattlack gegen Aufpreis von 25 € pro Fuß. | Módulos representados izquierdos, excepto indicación contraria. | Patas estándar pintados en negro, disponibles en champagne, titanio o lacado mate con un recargo de 25 € cada uno.

SETTANTA

composizioni | compositions | compositions | Kompositionen | composiciones

composizione 1 (rappresentata dx)
 composition 1 (rh in the picture)
 composition 1 (illustré à droite)
 Zusammenstellung 1 (rechts dargestellt)
 Composición 1 (representada a la derecha)

L W	H H	P D	CODICE CODE	Basic	Start	Extra	Light	Super	K	W	t-cliente com-fabric	ml l.mt.	m ³ kg
--------	--------	--------	----------------	-------	-------	-------	-------	-------	---	---	-------------------------	-------------	----------------------

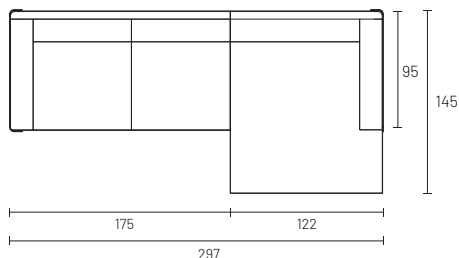

297	90	145	SETTC1	6.461	6.776	7.091	7.301	7.861	10.747	12.531	5.761	24,5	3,1 139
-----	----	-----	--------	-------	-------	-------	-------	-------	--------	--------	-------	------	------------

composizione 2 (rappresentata dx)
 composition 2 (rh in the picture)
 composition 2 (illustré à droite)
 Zusammenstellung 2 (rechts dargestellt)
 Composición 2 (representada a la derecha)

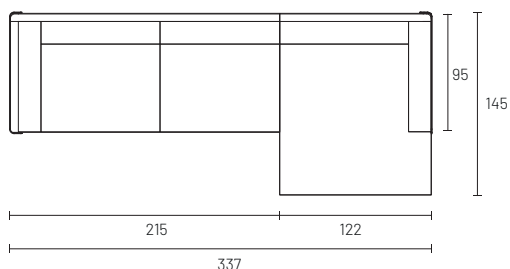

337	90	145	SETTC2	6.950	7.264	7.580	7.790	8.350	11.285	13.068	6.250	24,5	3,66 149
-----	----	-----	--------	-------	-------	-------	-------	-------	--------	--------	-------	------	-------------

composizione 3 (rappresentata dx)
 composition 3 (rh in the picture)
 composition 3 (illustré à droite)
 Zusammenstellung 3 (rechts dargestellt)
 Composición 3 (representada a la derecha)

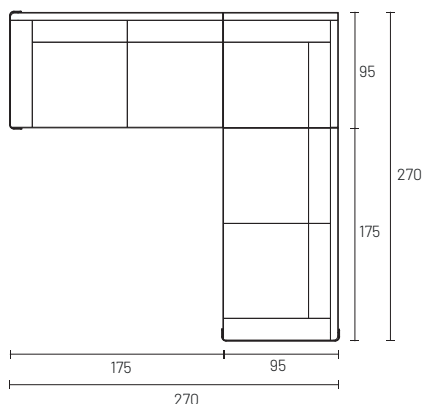

270	90	270	SETTC3	8.529	9.211	9.706	10.037	10.918	15.216	18.350	7.613	38,5	4 198
-----	----	-----	--------	-------	-------	-------	--------	--------	--------	--------	-------	------	----------

SETTANTA

composizioni | compositions | compositions | Kompositionen | composiciones

composizione 4 (rappresentata dx)
 composition 4 (rh in the picture)
 composition 4 (illustré à droite)
 Zusammenstellung 4 (rechts dargestellt)
 Composición 4 (representada a la derecha)

L	H	P	CODICE	Basic	Start	Extra	Light	Super	K	W	t-cliente	ml	m ³
W	H	D	CODE								com-fabric	l.mt.	kg

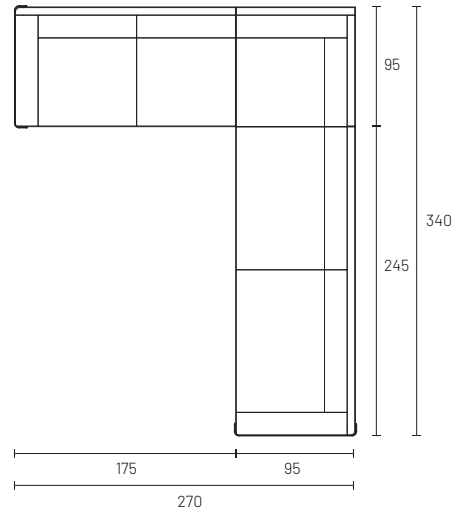

270	90	340	SETTC4	9.018	9.699	10.195	10.526	11.407	15.754	18.887	8.102	38,5	4,56 208
-----	----	-----	--------	-------	-------	--------	--------	--------	--------	--------	-------	------	-------------

SUPERNOVA



PIEDI | FEET | PIEDS | FÜSSE | PATAS



STRUTTURA: costruita in abete massello e multistrato e rivestita in poliuretano espanso. Parti secondarie e non strutturali in pannelli di fibre di legno.

SEDUTE: imbottite in poliuretano espanso ad alta densità e ricoperto con lenta memoria.

SCHIENALI E BRACCIOLI: imbottiti in piuma d'oca e fiocco.

PIEDI: modello Supernova in ferro verniciati neri. Disponibili in champagne, titanio, laccato opaco o RAL con maggiorazione: 25€ cadauno.

RIVESTIMENTO: sfoderabile in tessuto, parzialmente sfoderabile nella versione in pelle (solo cuscinate).

TESSUTO CLIENTE: il tessuto cliente non comprende le pelli. Per la metratura vedi listino.

STRUCTURE: made of solid spruce and plywood and covered with expanded polyurethane. Secondary and non-structural parts in fibreboard panels.

SEATS: padded with high density expanded polyurethane foam and covered with slow-memory foam layer.

BACKS AND ARMRESTS: padded with goose down and fiberfill.

FEET: Supernova model in black varnished iron. Available in champagne, titanium, matte or RAL lacquered with an additional charge of € 25 each.

UPHOLSTERY: removable cover in the fabric version, partially removable in the leather version (cushions only).

CUSTOMER FABRIC: Customer fabric does not include leather. For the required linear metres, see the price list.

STRUCTURE: construite en sapin massif et contreplaqué et rembourrée en polyuréthane expansé. Parties secondaires et non structurelles en panneaux de fibres de bois.

ASSISES: rembourrés en polyuréthane expansé à haute densité et recouverts de mousse à mémoire de forme.

DOSSIERS ET ACCOUDOIRS: rembourrés en plume d'oie et flocon.

PIEDS: modèle Supernova en fer laqué noir. Disponibles en champagne, titane, laqué mat ou RAL avec supplément : 25 € chacun.

REVÊTEMENT: tissu déhoussable, partiellement déhoussable en version cuir (seulement les coussins).

TISSU CLIENT: le tissu client n'inclut pas les cuirs. Pour le métrage, voir le tarif.

STRUKTUR: Fichte massiv und kaschierter Stoff, mit Polyurethanschaum. Nicht Teile aus Holzfaserverplatten.

SITZFLÄCHEN: gepolstert aus Polyurethanschaum mit hoher Dichte, mit strapazierfähigem Material bezogen.

RÜCKENLEHNEN UND ARMLEHNEN: gepolstert aus Gänsedaunen und Schleife.

FÜSSE: Modell Supernova aus schwarz lackiertem Eisen. Erhältlich in Champagner, Titan, matt lackiert oder RAL mit Aufpreis von 25 € pro Fuß.

ABDECKUNG: Vollständig abziehbar in der Stoffversion, bei der Lederversion teilweise abnehmbar (nur Kissen).

EIGENSTOFF: Vom Kunden bereitgestellter Stoff umfasst kein Leder. Für den benötigten Stoffverbrauch siehe Preisliste.

ESTRUCTURA: construido en abeto macizo y multicapa y revestido con poliuretano expandido. Partes secundarias y no estructurales en paneles de fibra de madera.

ASIENTOS: acolchado con poliuretano expandido de alta densidad y revestida con espuma viscoelástica.

RESPALDOS Y BRAZOS: acolchados con pluma de oca y copo.

PATAS: Modelo Supernova en hierro pintado negro. Disponibles en champán, titanio, lacado mate o RAL con un suplemento de 25 € cada uno.

REVESTIMIENTO: desenfundable en la versión tejido, parcialmente desenfundable en la versión piel (solo cojines).

TELA CLIENTE: El tejido proporcionado por el cliente no incluye pieles. Para el metraje, consulte la lista de precios.

SUPERNOVA

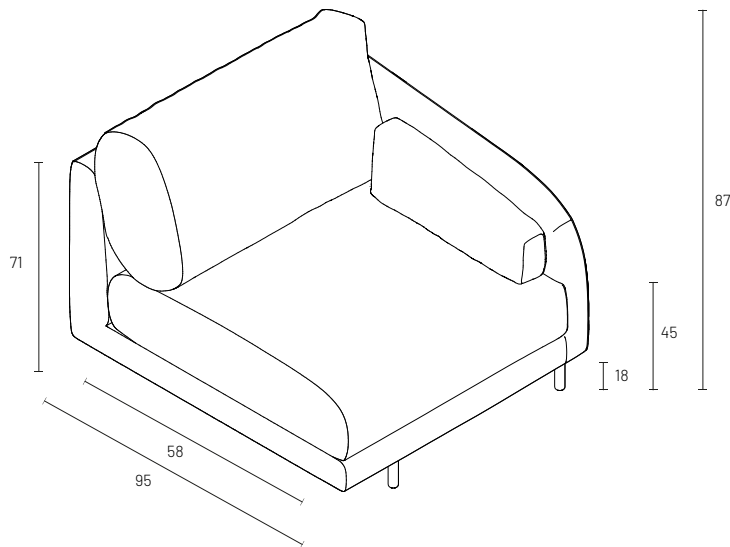
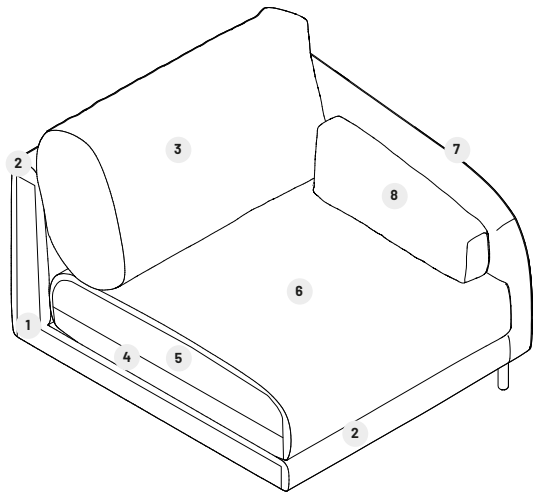

abete massello e multistrato rivestito resinato GR 150 + VELL

solid spruce and plywood covered with GR 150 + VELL resin-coated padding
 sapin massif et contreplaqué revêtu de résiné GR 150 + VELL
 Fichte massiv und kaschierter Stoff, mit Harzbeschichtung GR 150 + VELL bezogen
 abeto macizo y multicapa recubierto con resina GR 150 + VELL

1

poliuretano D40 PK
 polyurethane D40 PK
 polyuréthane D40 PK
 Polyurethan D40 PK
 poliuretano D40 PK

2

piuma d'oca e fiocco
 goose down and fiberfill
 plume d'oie et flocon
 Gänsefeder und Schleife
 pluma de ganso y lazo

3

poliuretano D32 ALX
 polyurethane D32 ALX
 polyuréthane D32 ALX
 Polyurethan D32 ALX
 poliuretano D32 ALX

4

poliuretano D35 olmosoff
 polyurethane D35 Olmosoff
 polyuréthane D35 olmosoff
 Polyurethan D35 Olmosoff
 poliuretano D35 Olmosoff

5

rivestimento resinato GR 200 + VELL
 GR 200 + VELL resin-coated upholstery.
 revêtement résiné GR 200 + VELL
 Harzbeschichtung GR 200 + VELL
 revestimiento resinado GR 200 + VELL

6

poliuretano D40 PK
 polyurethane D40 PK
 polyuréthane D40 PK
 Polyurethan D40 PK
 poliuretano D40 PK

7

piuma d'oca e fiocco
 goose down and fiberfill
 plume d'oie et flocon
 Gänsefeder und Schleife
 pluma de ganso y lazo

8

	 STRUTTURA STRUCTURE STRUCTURE STRUKTUR ESTRUCTURA	 SCHIENALI E BRACCIOLI BACKRESTS AND ARMRESTS DOSSIERS ET ACCOUDOIRS RÜCKENLEHNEN UND ARMLEHNEN RESPALDOS Y REPOSABRAZOS	 SEDUTA SEAT ASSISE SITZFLÄCHE ASIENTO
SFODERABILE REMOVABLE DÉHOUSSABLE ABZIEHBAR DESENFUNDABLE	 fabric	 fabric	 fabric
NON SFODERABILE NON REMOVABLE NON DÉHOUSSABLE NICHT ABZIEHBAR NO DESENFUNDABLE	 leather	-	-

SUPERNOVA

moduli | units | modules | module | módulos

divano 2 posti
2-seat sofa
canapé 2 places
Sofa 2 Sitze
sofa 2 plazos

L W	H H	P D	CODICE CODE	Basic	Start	Extra	Light	Super	K	W	t-cliente com-fabric	ml l.mt.	m ³ kg
--------	--------	--------	----------------	-------	-------	-------	-------	-------	---	---	-------------------------	-------------	----------------------

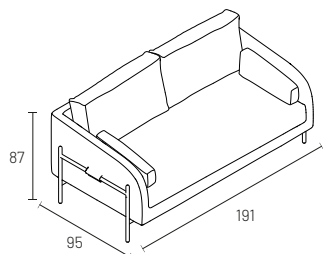

191	87	95	DI01SUAB000	3.064	3.254	3.443	3.570	3.907	5.130	6.140	2.692	11,5	1,1 69
-----	----	----	-------------	-------	-------	-------	-------	-------	-------	-------	-------	------	-----------

divano 2,5 posti
2.5-seat sofa
canapé 2,5 places
Sofa 2,5 Sitze
sofa 2,5 plazos

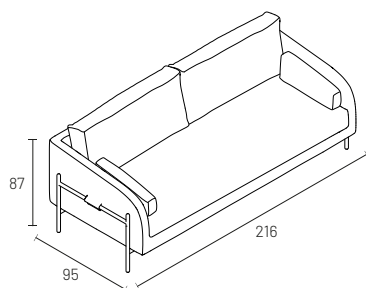

216	87	95	DI01SUAC000	3.324	3.522	3.720	3.852	4.204	5.475	6.527	2.934	12	1,16 74
-----	----	----	-------------	-------	-------	-------	-------	-------	-------	-------	-------	----	------------

divano 3 posti
3-seat sofa
canapé 3 places
Sofa 3 Sitze
sofa 3 plazos

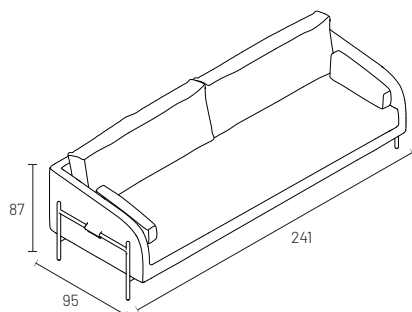

241	87	95	DI01SUAD000	3.514	3.720	3.927	4.064	4.431	5.753	6.850	3.105	12,5	1,3 85
-----	----	----	-------------	-------	-------	-------	-------	-------	-------	-------	-------	------	-----------

Piedini standard verniciati neri, disponibili in champagne, titanio, laccato opaco o RAL con maggiorazione: 25 € cadauno. | Standard feet painted black, also available in champagne, titanium, matte or RAL lacquered with an additional charge of € 25 each. | Pieds standard laqué en noir, disponibles en champagne, titane laqué mat ou RAL avec supplément : 25 € chacun. | Standardfüße schwarz lackiert, erhältlich in Champagner, Titan, matt lackiert oder RAL mit Aufpreis von 25 € pro Fuß. | MPatas estándar pintados en negro, disponibles en champagne, titanio, lacado mate o RAL con un recargo de 25 € cada uno.

laterale 1 posto
1-seat side element
latéral 1 place
seitliches Modul 1 Sitz
módulo lateral 1 plazo

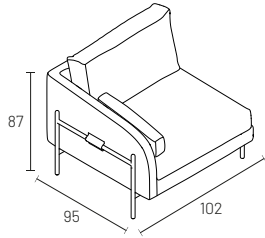

	L W	H H	P D	CODICE CODE	Basic	Start	Extra	Light	Super	K	W	t-cliente com-fabric	ml l.mt.	m ³ kg
dx rh droite re. dcha sx	102	87	95	DI01SUBAD00	1.822	1.912	2.003	2.064	2.225	2.835	3.317	1.669	5,5	0,53 35
lh gauche li. izda	102	87	95	DI01SUBAS00	1.822	1.912	2.003	2.064	2.225	2.835	3.317	1.669	5,5	0,53 35

laterale 2 posti
2-seat side element
latéral 2 places
seitliches Modul 2 Sitze
módulo lateral 2 plazos

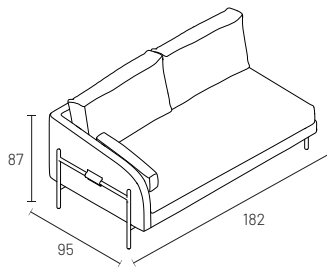

dx rh droite re. dcha sx	182	87	95	DI01SUBBD00	2.704	2.885	3.067	3.188	3.511	4.679	5.644	2.350	11	1,05 59
lh gauche li. izda	182	87	95	DI01SUBBS00	2.704	2.885	3.067	3.188	3.511	4.679	5.644	2.350	11	1,05 59

laterale 2,5 posti
2.5-seat side element
latéral 2,5 places
seitliches Modul 2,5 Sitze
módulo lateral 2,5 plazos

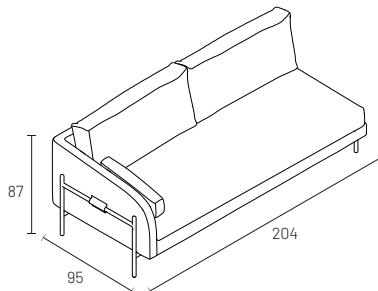

dx rh droite re. dcha sx	204	87	95	DI01SUBCD00	2.964	3.154	3.344	3.470	3.808	5.030	6.041	2.592	11,5	1,13 64
lh gauche li. izda	204	87	95	DI01SUBCS00	2.964	3.154	3.344	3.470	3.808	5.030	6.041	2.592	11,5	1,13 64

Moduli rappresentati sx se non specificato diversamente. | Piedini standard verniciati neri, disponibili in champagne, titanio, laccato opaco o RAL con maggiorazione: 25 € cadauno. | Units represented as lh unless otherwise specified. | Standard feet painted black, also available in champagne, titanium, matte or RAL lacquered with an additional charge of € 25 each. | Modules représentés à gauche sauf indication contraire. | Pieds standard laqué en noir, disponibles en champagne, titane laqué mat ou RAL avec supplément : 25 € chacun. | Module links dargestellt, sofern nicht anders angegeben. | Standardfüße schwarz lackiert, erhältlich in Champagner, Titan, matt lackiert oder RAL mit Aufpreis von 25 € pro Fuß. | Módulos representados izquierdos, excepto indicación contraria. | Patas estándar pintados en negro, disponibles en champagne, titanio, lacado mate o RAL con un recargo de 25 € cada uno.

SUPERNOVA

moduli | units | modules | module | módulos

laterale 3 posti

3-seat side element
latéral 3 places
seitliches Modul 3 Sitze
módulo lateral 3 plazas

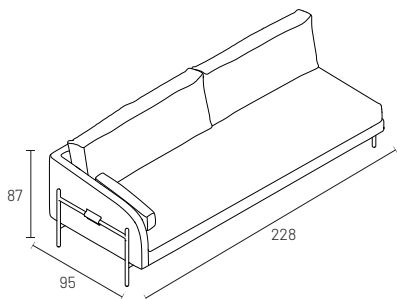

	L W	H H	P D	CODICE CODE	Basic	Start	Extra	Light	Super	K	W	t-cliente com-fabric	ml l.mt.	m³ kg
dx rh droite	228	87	95	DI01SUBDD00	3.154	3.352	3.550	3.682	4.034	5.305	6.357	2.764	12	1,57 75
re. dcha sx lh gauche	228	87	95	DI01SUBDS00	3.154	3.352	3.550	3.682	4.034	5.305	6.357	2.764	12	1,57 75
li. izda														

isola

sectional element
méridienne
chaise longue
chaise longue

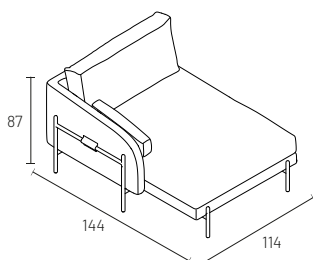

dx rh droite	114	87	144	DI01SUD0D00	2.507	2.655	2.804	2.903	3.167	4.132	4.922	2.226	8,5	1,2 59
re. dcha sx lh gauche	114	87	144	DI01SUD0S00	2.507	2.655	2.804	2.903	3.167	4.132	4.922	2.226	8,5	1,2 59
li. izda														

meridiana

chaise longue
chaise longue
Ottomane
peninsula

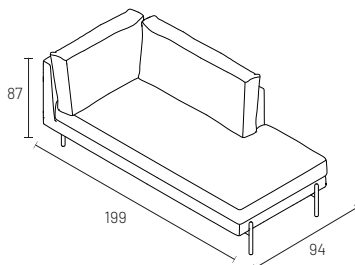

dx rh droite	94	87	199	DI01SUE0D00	3.036	3.201	3.366	3.476	3.769	4.836	5.713	2.719	10	1,4 74
re. dcha sx lh gauche	94	87	199	DI01SUE0S00	3.036	3.201	3.366	3.476	3.769	4.836	5.713	2.719	10	1,4 74
li. izda														

raffigurato dx - non presente il piede esterno

rh in the picture - external foot not present
illustré à droite - pied extérieur absent
rechts dargestellt - Seitlicher Fuß nicht dargestellt
representado dcho - no presente el pie lateral

Moduli rappresentati sx se non specificato diversamente. | Piedini standard verniciati neri, disponibili in champagne, titanio, laccato opaco o RAL con maggiorazione: 25 € cadauno. | Units represented as lh unless otherwise specified. | Standard feet painted black, also available in champagne, titanium, matte or RAL lacquered with an additional charge of € 25 each. | Modules représentés à gauche sauf indication contraire. | Pieds standard laqué en noir, disponibles en champagne, titane laqué mat ou RAL avec supplément : 25 € chacun. | Module links dargestellt, sofern nicht anders angegeben. | Standardfüße schwarz lackiert, erhältlich in Champagner, Titan, matt lackiert oder RAL mit Aufpreis von 25 € pro Fuß. | Módulos representados izquierdos, excepto indicación contraria. | Patas estándar pintados en negro, disponibles en champagne, titanio, lacado mate o RAL con un recargo de 25 € cada uno.

SUPERNOVA

moduli | units | modules | module | módulos

pouf
pouf
pouf
pouf
pouf

L W	H H	P D	CODICE CODE	Basic	Start	Extra	Light	Super	K	W	t-cliente com-fabric	ml l.mt.	m ³ kg
--------	--------	--------	----------------	-------	-------	-------	-------	-------	---	---	-------------------------	-------------	----------------------

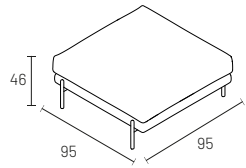

95	46	95	DI01SULA000	1.025	1.083	1.141	1.179	1.282	1.691	1.999	947	3,5	0,4 20
----	----	----	-------------	-------	-------	-------	-------	-------	-------	-------	-----	-----	-----------

composizione 1 (rappresentata dx)
 composition 1 (rh in the picture)
 composition 1 (illustré à droite)
 Zusammenstellung 1 (rechts dargestellt)
 Composición 1 (representada a la derecha)

L W	H H	P D	CODICE CODE	Basic	Start	Extra	Light	Super	K	W	t-cliente com-fabric	ml l.mt.	m ³ kg
--------	--------	--------	----------------	-------	-------	-------	-------	-------	---	---	-------------------------	-------------	----------------------

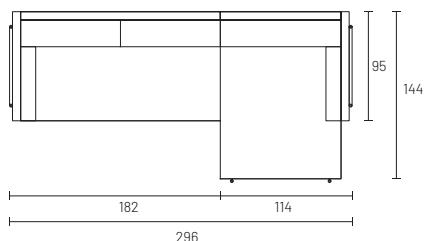

296	87	144	SUPC1	5.211	5.540	5.871	6.091	6.678	8.811	10.566	4.576	19,5	2.25 118
-----	----	-----	-------	-------	-------	-------	-------	-------	-------	--------	-------	------	-------------

composizione 2 (rappresentata dx)
 composition 2 (rh in the picture)
 composition 2 (illustré à droite)
 Zusammenstellung 2 (rechts dargestellt)
 Composición 2 (representada a la derecha)

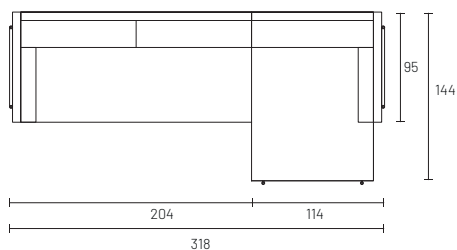

318	87	144	SUPC2	5.471	5.809	6.148	6.373	6.975	9.162	10.963	4.818	20	2.33 123
-----	----	-----	-------	-------	-------	-------	-------	-------	-------	--------	-------	----	-------------

composizione 3 (rappresentata dx)
 composition 3 (rh in the picture)
 composition 3 (illustré à droite)
 Zusammenstellung 3 (rechts dargestellt)
 Composición 3 (representada a la derecha)

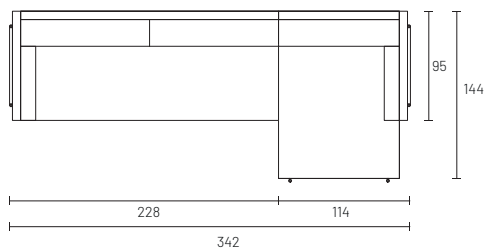

342	87	144	SUPC3	5.661	6.007	6.354	6.585	7.201	9.437	11.279	4.990	20,5	2.77 134
-----	----	-----	-------	-------	-------	-------	-------	-------	-------	--------	-------	------	-------------

SUPERNOVA

composizioni | compositions | compositions | Kompositionen | composiciones

composizione 4 (rappresentata dx)
 composition 4 (rh in the picture)
 composition 4 (illustré à droite)
 Zusammenstellung 4 (rechts dargestellt)
 Composición 4 (representada a la derecha)

L	H	P	CODICE	Basic	Start	Extra	Light	Super	K	W	t-cliente	ml	m ³
W	H	D	CODE								com-fabric	l.mt.	kg

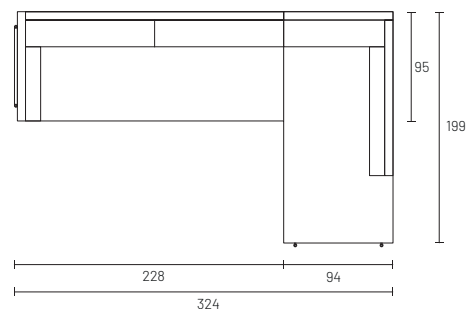

324	87	199	SUPC4	6.190	6.553	6.916	7.158	7.803	10.141	12.070	5.483	22	2.97 149
-----	----	-----	-------	-------	-------	-------	-------	-------	--------	--------	-------	----	-------------

SWING



**PIEDINI A | FEET A | PIEDS A | FÜSSE A |
PATAS A**



**PIEDINI B | FEET B | PIEDS B | FÜSSE B |
PATAS B**



STRUTTURA: costruita in abete massello e multistrato e rivestita in poliuretano espanso. Parti secondarie e non strutturali in pannelli di fibre di legno.

SEDUTE: anima in poliuretano espanso rivestita con materasso in piuma d'oca adeguatamente trapuntato.

SCHIENALI E BRACCIOLI: anima in poliuretano espanso per sorreggere il materassino in piuma d'oca adeguatamente trapuntato.

PIEDINI: in metallo verniciato nero. Disponibili in champagne, titanio o laccato opaco con maggiorazione: 25€ cadauno. Piedini A di serie, B optional da indicare in fase d'ordine.

RIVESTIMENTO: sfoderabile in tessuto, parzialmente sfoderabile nella versione in pelle (solo cuscinate). Optional pianale in finitura diversa rispetto al tessuto di schienale e seduta.*

TESSUTO CLIENTE: il tessuto cliente non comprende le pelli. Per la metratura vedi listino.

STRUCTURE: made of solid spruce and plywood and covered with expanded polyurethane. Secondary and non-structural parts in fibreboard panels.

SEATS: core part made of expanded polyurethane covered with the quilted mattress in goose feather.

BACKS AND ARMRESTS: core part made of expanded polyurethane to support the quilted mattress in goose feather.

FEET: in black varnished metal. Also available in champagne, titanium, or matte lacquered with an additional charge of €25 each feet. Standard feet type A, optional type B to be marked in the order.

UPHOLSTERY: removable cover in the fabric version, partially removable in the leather version (cushions only). Optional base in a different finish compared to the fabric of backrest and seat.*

CUSTOMER FABRIC: Customer fabric does not include leather. For the required linear metres, see the price list.

STRUCTURE: construite en sapin massif et contreplaqué et rembourrée en polyuréthane expansé. Parties secondaires et non structurelles en panneaux de fibres de bois.

ASSISES: âme en polyuréthane expansé recouverte d'un matelas en plume d'oie correctement matelassé.

DOSSIERS ET ACCOUDOIRS: âme en polyuréthane expansé pour soutenir le matelas en plume d'oie correctement matelassé.

PIEDS: en métal laqué en noir. Disponibles en champagne, titane ou laqué mat avec supplément : 25 € chacun. Pieds A de série, patins B en option à préciser lors de la commande.

REVÊTEMENT: tissu déhoussable, partiellement déhoussable en version cuir (seulement les coussins). Plateau avec une finition différente de celle du tissu du dossier et de l'assise.*

TISSU CLIENT: le tissu client n'inclut pas les cuirs. Pour le métrage, voir le tarif.

STRUKTUR: Fichte massiv und kaschierter Stoff, mit Polyurethanschaum. Nicht Teile aus Holzfasernplatten.

SITZFLÄCHEN: Kern aus Polyurethanschaum, bezogen mit einer angemessen gesteppten Daunematratze.

RÜCKENLEHNEN UND ARMLEHNEN: Kern aus Polyurethanschaum, zur Unterstützung einer angemessen gesteppten Daunenaufgabe.

FÜSSE: aus schwarz lackiertem Metall. Auch erhältlich in Champagne, Titan oder Mattlack gegen Aufpreis von 25 € pro Fuß. Serienmäßige Füße Typ A, optional Füße Typ B (bei der Bestellung anzugeben).

ABDECKUNG: Vollständig abziehbar in der Stoffversion, bei der Lederversion teilweise abnehmbar (nur Kissen). Optional Einfassung mit einem anderen Stoff als dem der Rückenlehne und der Sitzfläche.*

EIGENSTOFF: Vom Kunden bereitgestellter Stoff umfasst kein Leder. Für den benötigten Stoffverbrauch siehe Preisliste.

ESTRUCTURA: construido en abeto macizo y multicapa y revestido con poliuretano expandido. Partes secundarias y no estructurales en paneles de fibra de madera.

ASIENTOS: núcleo de poliuretano expandido revestido con un colchón de pluma de ganso adecuadamente punteado.

RESPALDOS Y BRAZOS: núcleo de poliuretano expandido para sostener el colchoncillo de pluma de ganso adecuadamente punteado.

PATAS: en metal lacado negro. Disponibles en champagne, titanio o lacado mate con recargo de 25 € cada uno. Estándar pata tipo A, a petición pata B (indicar siempre en el pedido).







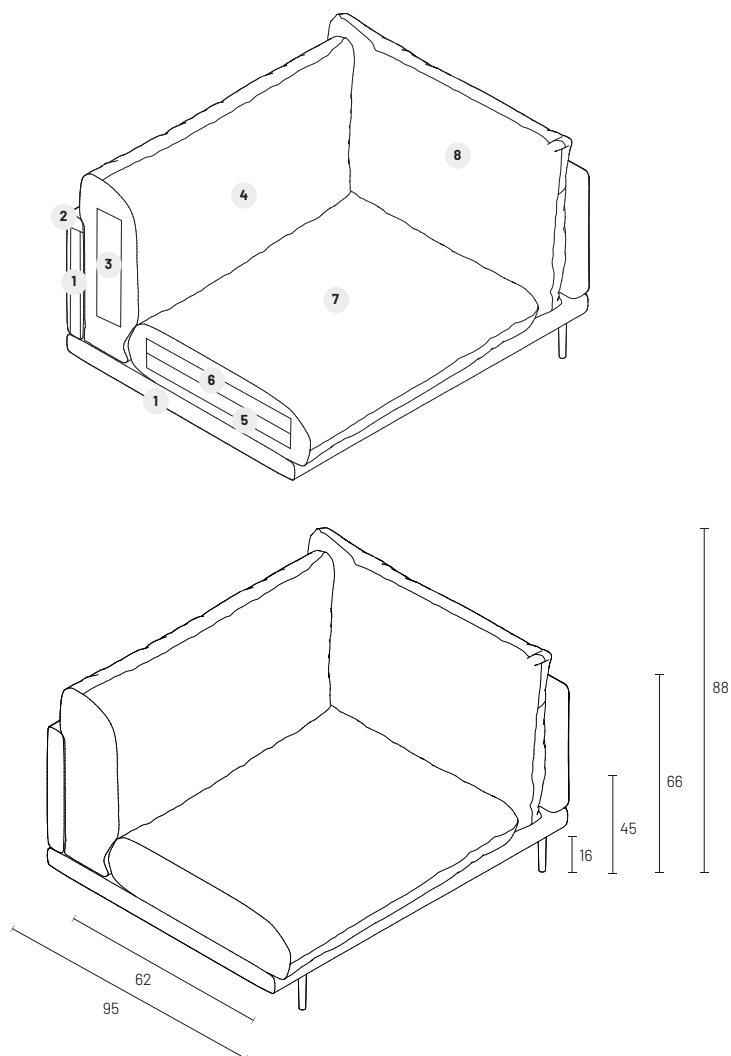

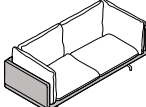
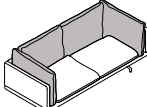
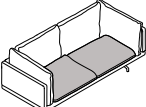

REVESTIMIENTO: desenfundable en la versión tejido, parcialmente desenfundable en la versión piel (solo cojines). A petición plataforma con tejido diferente al del respaldo y del asiento.*

TELA CLIENTE: El tejido proporcionado por el cliente no incluye pieles. Para el metraje, consulte la lista de precios.

SWING



- 1 abete massello e multistrato rivestito in poliuretano D21 T + accoppiato grigio 8 mm
solid spruce and plywood covered with D21 T polyurethane + 8 mm grey laminated fabric
sapin massif et contreplaqué revêtu de polyuréthane D21 T + doublage gris 8 mm
Fichte massiv und kaschierter Stoff beschichtet mit Polyurethan D21 T und kaschierter Stoff grau 8 mm
abeto macizo y multicapa revestida con poliuretano D21 T + material grau 8 mm
acoplado
- 2 poliuretano D40 PK
polyurethane D40 PK
polyuréthane D40 PK
Polyurethan D40 PK
poliuretano D40 PK
- 3 poliuretano D25 PSE
polyurethane D25 PSE
polyuréthane D25 PSE
Polyurethan D25 PSE
poliuretano D25 PSE
- 4 piuma d'oca e fiocco
goose down and fiberfill
plume d'oie et flocon
Gänsefeder und Schleife
pluma de ganso y lazo
- 5 poliuretano D50 PFFR
polyurethane D50 PFFR
polyuréthane D50 PFFR
Polyurethan D50 PFFR
poliuretano D50 PFFR
- 6 poliuretano D35 PF-FR
polyurethane D35 PF-FR
polyuréthane D35 PF-FR
Polyurethan D35 PF-FR
poliuretano D35 PF-FR
- 7 piuma d'oca e fiocco
goose down and fiberfill
plume d'oie et flocon
Gänsefeder und Schleife
pluma de ganso y lazo
- 8 fibra di poliestere D25 PSE
D25 PSE polyester fiber
fibre de polyester D25 PSE
Polyesterfaser D25 PSE
fibra de poliéster D25 PSE

	 STRUTTURA STRUCTURE STRUCTURE STRUKTUR ESTRUCTURA	 SCHIENALI E BRACCIOLI BACKRESTS AND ARMRESTS DOSSIERS ET ACCOUDOIRS RÜCKENLEHNEN UND ARMLEHNEN RESPALDOS Y REPOSABRAZOS	 SEDUTA SEAT ASSISE SITZFLÄCHE ASIENTO
SFODERABILE REMOVABLE DÉHOUSSABLE ABZIEHBAR DESENFUNDABLE	 fabric  simil leather *	 fabric  simil leather  leather	 fabric  simil leather  leather
NON SFODERABILE NON REMOVABLE NON DÉHOUSSABLE NICHT ABZIEHBAR NO DESENFUNDABLE	 leather *	-	-

* Optional pianale in finitura diversa rispetto al tessuto di schienale e seduta. Maggiorazione del 5% per ogni aumento di categoria tessuto. (Nel caso di schienale e seduta di categoria maggiore rispetto al pianale manterrà la medesima categoria.)

* Optional base in a different finish compared to the fabric of backrest and seat. 5% surcharge for any fabric category increase (in case of backrest and seat covered in a higher category fabric, the base will upgrade to the same category).

* Plateau avec finition différente de celle du tissu du dossier et de l'assise. Majoration de 5 % pour chaque augmentation de catégorie de tissu. (Dans le cas où le dossier et l'assise seraient d'une catégorie supérieure à celle du plateau, ce dernier conservera la même catégorie.)

* Optional Sitzbezug aus einem anderen Stoff als der Rückenlehne und der Sitzfläche. Aufpreis von 5 % für jede höhere Stoffkategorie. (Wenn Rückenlehne und Sitzfläche einer höheren Preiskategorie angehören als der Sitzbezug, bleibt die Kategorie unverändert.)

* Plataforma a petición con tejido diferente al del respaldo y del asiento. Recargo del 5 % por cada aumento de categoría del tejido. (En caso de que el respaldo y el asiento sean de una categoría de precio superior a la de la plataforma, se mantendrá la misma categoría).

SWING

moduli | units | modules | module | módulos

divano 2 posti
2-seat sofa
canapé 2 places
Sofa 2 Sitze
sofa 2 plazos

L W	H H	P D	CODICE CODE	Basic	Start	Extra	Light	Super	K	W	t-cliente com-fabric	ml l.mt.	m ³ kg
--------	--------	--------	----------------	-------	-------	-------	-------	-------	---	---	-------------------------	-------------	----------------------

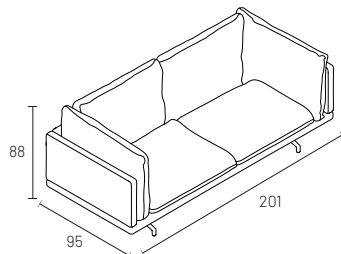

201	88	95	DI01SWAB000	3.101	3.327	3.553	3.704	4.106	5.580	6.782	2.679	16,5	1,62 65
-----	----	----	-------------	-------	-------	-------	-------	-------	-------	-------	-------	------	------------

divano 2,5 posti
2.5-seat sofa
canapé 2,5 places
Sofa 2,5 Sitze
sofa 2,5 plazos

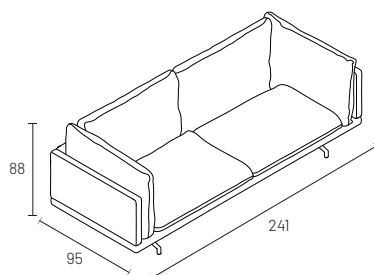

241	88	95	DI01SWAC000	3.204	3.426	3.649	3.797	4.193	5.645	6.828	2.788	16,5	1,94 70
-----	----	----	-------------	-------	-------	-------	-------	-------	-------	-------	-------	------	------------

divano 3 posti
3-seat sofa
canapé 3 places
Sofa 3 Sitze
sofa 3 plazos

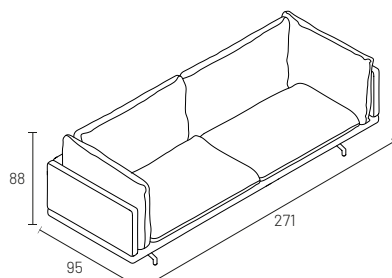

271	88	95	DI01SWAD000	3.289	3.508	3.728	3.874	4.264	5.693	6.858	2.880	16,5	2,2 75
-----	----	----	-------------	-------	-------	-------	-------	-------	-------	-------	-------	------	-----------

Piedini standard verniciati neri, disponibili in champagne, titanio o laccato opaco con maggiorazione: 25 € cadauno. | Standard feet painted black, also available in champagne, titanium, or matte lacquered with an additional charge of € 25 each. | Pieds standard laqué en noir, disponibles en champagne, titane ou laqué mat avec supplément : 25 € chacun. | Standardfüße schwarz lackiert, erhältlich in Champagne, Titan oder Mattlack gegen Aufpreis von 25 € pro Fuß. | Patas estándar pintados en negro, disponibles en champagne, titanio o lacado mate con un recargo de 25 € cada uno.

laterale 2 posti
2-seat side element
latéral 2 places
seitliches Modul 2 Sitze
módulo lateral 2 plazas

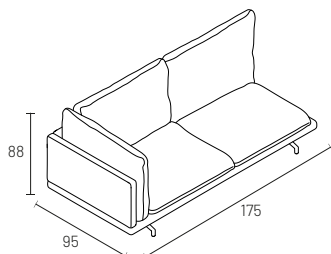

	L W	H H	P D	CODICE CODE	Basic	Start	Extra	Light	Super	K	W	t-cliente com-fabric	ml l.mt.	m ³ kg
dx rh droite re. dcha	175	88	95	DI01SWBBD00	2.728	2.917	3.107	3.234	3.571	4.821	5.830	2.386	13,5	1,99 70
sx lh gauche li. izda	175	88	95	DI01SWBBS00	2.728	2.917	3.107	3.234	3.571	4.821	5.830	2.386	13,5	1,99 70

laterale 2,5 posti
2.5-seat side element
latéral 2,5 places
seitliches Modul 2,5 Sitze
módulo lateral 2,5 plazas

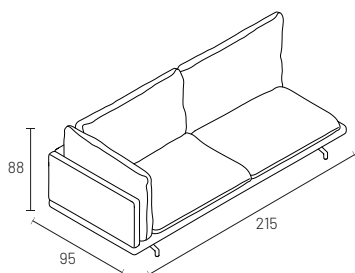

dx rh droite re. dcha	215	88	95	DI01SWBCD00	2.880	3.070	3.259	3.386	3.723	4.973	5.982	2.538	13,5	1,74 65
sx lh gauche li. izda	215	88	95	DI01SWBCS00	2.880	3.070	3.259	3.386	3.723	4.973	5.982	2.538	13,5	1,74 65

laterale 3 posti
3-seat side element
latéral 3 places
seitliches Modul 3 Sitze
módulo lateral 3 plazas

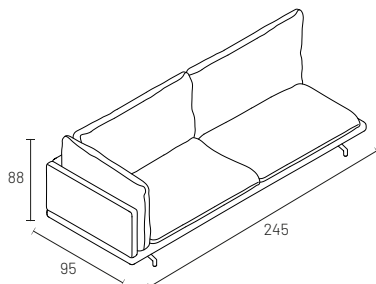

dx rh droite re. dcha	245	88	95	DI01SWBDD00	2.918	3.102	3.286	3.408	3.735	4.947	5.926	2.586	13,5	1,42 60
sx lh gauche li. izda	245	88	95	DI01SWBDS00	2.918	3.102	3.286	3.408	3.735	4.947	5.926	2.586	13,5	1,42 60

Moduli rappresentati sx se non specificato diversamente. | Piedini standard verniciati neri, disponibili in champagne, titanio o laccato opaco con maggiorazione: 25 € cadauno. | Units represented as lh unless otherwise specified. | Standard feet painted black, also available in champagne, titanium, or matte lacquered with an additional charge of € 25 each. | Modules représentés à gauche sauf indication contraire. | Pieds standard laqué en noir, disponibles en champagne, titane ou laqué mat avec supplément : 25 € chacun. | Module links dargestellt, sofern nicht anders angegeben. | Standardfüße schwarz lackiert, erhältlich in Champagne, Titan oder Mattlack gegen Aufpreis von 25 € pro Fuß. | Módulos representados izquierdos, excepto indicación contraria. | Patas estándar pintados en negro, disponibles en champagne, titanio o lacado mate con un recargo de 25 € cada uno.

SWING

moduli | units | modules | module | módulos

angolo
corner unit
angle
Ecke
ángulo

L W	H H	P D	CODICE CODE	Basic	Start	Extra	Light	Super	K	W	t-cliente com-fabric	ml l.mt.	m ³ kg
--------	--------	--------	----------------	-------	-------	-------	-------	-------	---	---	-------------------------	-------------	----------------------

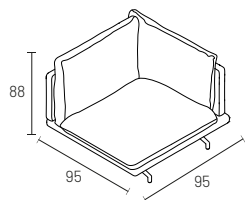

95	88	95	DI01SWFB000	2.336	2.455	2.574	2.653	2.864	3.676	4.307	2.151	9,5	0,76 40
----	----	----	-------------	-------	-------	-------	-------	-------	-------	-------	-------	-----	------------

isola
sectional element
mériidienne
chaise longue
chaise longue

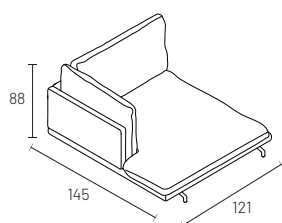

dx rh droite re. dcha	121	88	145	DI01SWD0D00	2.446	2.588	2.730	2.824	3.076	4.031	4.785	2.210	10	1,49 60
sx lh gauche li. izda	121	88	145	DI01SWD0S00	2.446	2.588	2.730	2.824	3.076	4.031	4.785	2.210	10	1,49 60

meridiana
chaise longue
chaise longue
Ottomane
peninsula

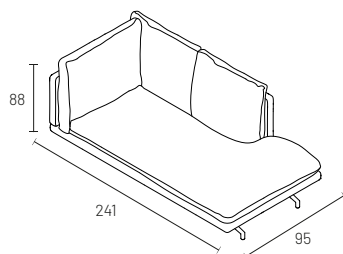

dx rh droite re. dcha	95	88	241	DI01SWE0D00	3.078	3.294	3.510	3.654	4.039	5.451	6.600	2.677	16,5	1,94 68
sx lh gauche li. izda	95	88	241	DI01SWE0S00	3.078	3.294	3.510	3.654	4.039	5.451	6.600	2.677	16,5	1,94 68

raffigurato dx
rh in the figure
illustré à droite
rechts dargestellt
representado dcho

Moduli rappresentati sx se non specificato diversamente. | Piedini standard verniciati neri, disponibili in champagne, titanio o laccato opaco con maggiorazione: 25 € cadauno. | Units represented as lh unless otherwise specified. | Standard feet painted black, also available in champagne, titanium, or matte lacquered with an additional charge of € 25 each. | Modules représentés à gauche sauf indication contraire. | Pieds standard laqué en noir, disponibles en champagne, titane ou laqué mat avec supplément : 25 € chacun. | Module links dargestellt, sofern nicht anders angegeben. | Standardfüße schwarz lackiert, erhältlich in Champagne, Titan oder Mattlack gegen Aufpreis von 25 € pro Fuß. | Módulos representados izquierdos, excepto indicación contraria. | Patas estándar pintados en negro, disponibles en champagne, titanio o lacado mate con un recargo de 25 € cada uno.

SWING

moduli | units | modules | module | módulos

pouf
pouf
pouf
pouf
pouf

L W	H H	P D	CODICE CODE	Basic	Start	Extra	Light	Super	K	W	t-cliente com-fabric	ml l.mt.	m³ kg
--------	--------	--------	----------------	-------	-------	-------	-------	-------	---	---	-------------------------	-------------	----------

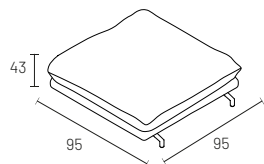

95	43	95	DI01SWLA000	1.159	1.197	1.235	1.260	1.327	1.641	1.842	1.154	3,9	0,4 20
----	----	----	-------------	-------	-------	-------	-------	-------	-------	-------	-------	-----	-----------

portariviste in cuoio
magazine rack in hard leather
porte-revues en cuir
Zeitschriftenhalter in Hartleder
revistero en cuero

L W	H H	P D	CODICE CODE	Prezzo Price	m³ kg
--------	--------	--------	----------------	-----------------	----------

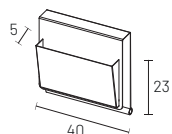

40	23	5	DI0191X1000	190	0,02 0,8
----	----	---	-------------	-----	-------------

Piedini standard verniciati neri, disponibili in champagne, titanio o laccato opaco con maggiorazione: 25 € cadauno. | Standard feet painted black, also available in champagne, titanium, or matte lacquered with an additional charge of € 25 each. | Pieds standard laqué en noir, disponibles en champagne, titane ou laqué mat avec supplément : 25 € chacun. | Standardfüße schwarz lackiert, erhältlich in Champagne, Titan oder Mattlack gegen Aufpreis von 25 € pro Fuß. | Patas estándar pintados en negro, disponibles en champagne, titanio o lacado mate con un recargo de 25 € cada uno.

composizione 1 (rappresentata dx)
 composition 1 (rh in the picture)
 composition 1 (illustré à droite)
 Zusammenstellung 1 (rechts dargestellt)
 Composición 1 (representada a la derecha)

L W	H H	P D	CODICE CODE	Basic	Start	Extra	Light	Super	K	W	t-cliente com-fabric	ml l.mt.	m ³ kg
--------	--------	--------	----------------	-------	-------	-------	-------	-------	---	---	-------------------------	-------------	----------------------

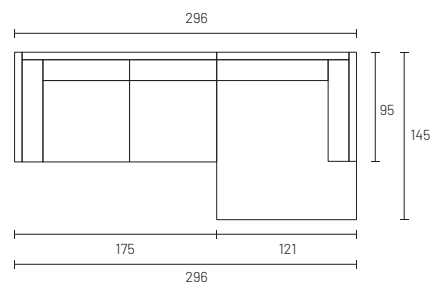

296	88	145	SWINC1	5.174	5.505	5.837	6.058	6.647	8.852	10.615	4.596	23,5	3,48 130
-----	----	-----	--------	-------	-------	-------	-------	-------	-------	--------	-------	------	-------------

composizione 2 (rappresentata dx)
 composition 2 (rh in the picture)
 composition 2 (illustré à droite)
 Zusammenstellung 2 (rechts dargestellt)
 Composición 2 (representada a la derecha)

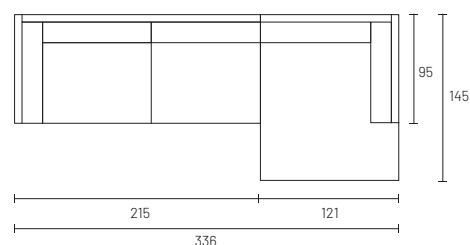

336	88	145	SWINC2	5.326	5.658	5.989	6.210	6.799	9.004	10.767	4.748	23,5	3,23 125
-----	----	-----	--------	-------	-------	-------	-------	-------	-------	--------	-------	------	-------------

composizione 3 (rappresentata dx)
 composition 3 (rh in the picture)
 composition 3 (illustré à droite)
 Zusammenstellung 3 (rechts dargestellt)
 Composición 3 (representada a la derecha)

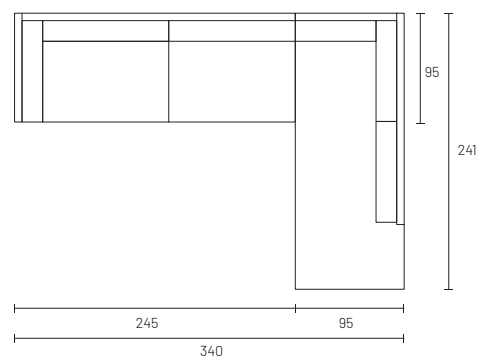

340	88	241	SWINC3	5.996	6.396	6.796	7.062	7.774	10.398	12.526	5.263	30	3,36 128
-----	----	-----	--------	-------	-------	-------	-------	-------	--------	--------	-------	----	-------------

SWING

composizioni | compositions | compositions | Kompositionen | composiciones

composizione 4 (rappresentata dx)
 composition 4 (rh in the picture)
 composition 4 (illustré à droite)
 Zusammenstellung 4 (rechts dargestellt)
 Composición 4 (representada a la derecha)

L	H	P	CODICE	Basic	Start	Extra	Light	Super	K	W	t-cliente	ml	m³
W	H	D	CODE								com-fabric	l.mt.	kg

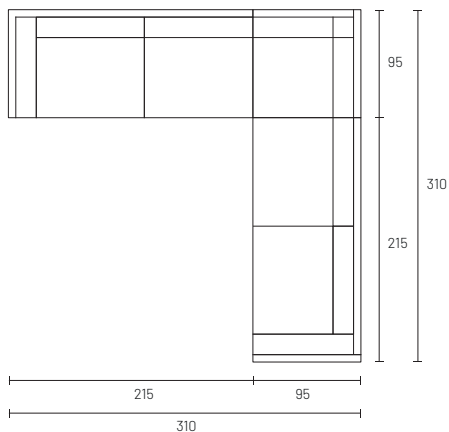

310	88	310	SWINC4	8.096	8.595	9.092	9.425	10.310	13.622	16.271	7.227	36,5	4,24 170
-----	----	-----	--------	-------	-------	-------	-------	--------	--------	--------	-------	------	-------------

TRAMA

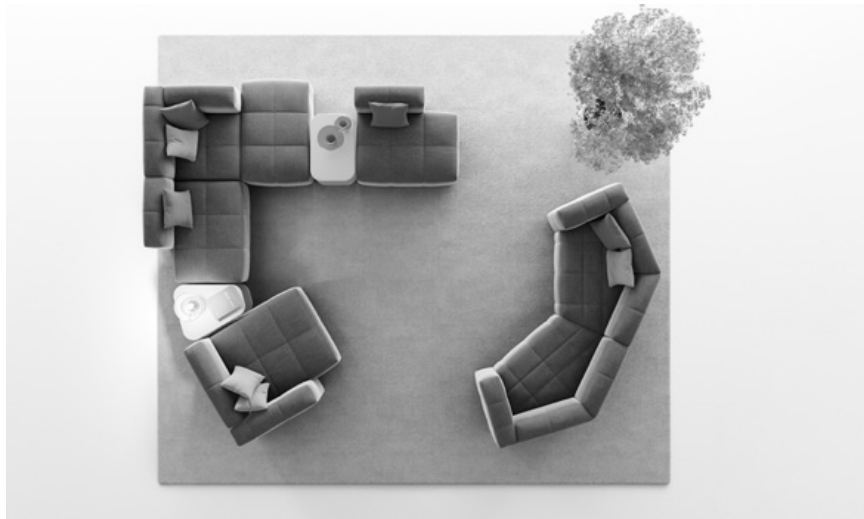

PIEDINI | FEET | PIEDS | FÜSSE | PATAS



STRUTTURA: costruita in abete massello e multistrato e rivestita in poliuretano espanso. Parti secondarie e non strutturali in pannelli di fibre di legno.
SEDUTE: imbottite in poliuretano espanso a densità differenziata e rivestite con un trapuntino in piuma (100%).
SCHIENALI E BRACCIOLI: imbottiti in poliuretano espanso con tampone di poliestere e rivestiti con un trapuntino in piuma (100%). Disponibili in due altezze: H. 66 cm e H. 78 cm.
PIEDINI: in plastica neri.
RIVESTIMENTO: Non disponibile in Fintapelle vintage/intreccio (Extra) e in Cartagena (Start). Sfoderabile in tessuto. Disponibile con o senza trapuntatura.
TESSUTO CLIENTE: il tessuto cliente non comprende le pelli. Per la metratura vedi listino.

STRUCTURE: made of solid spruce and plywood and covered with expanded polyurethane. Secondary and non-structural parts in fibreboard panels.
SEATS: padded with differentiated density expanded polyurethane foam and covered with a 100% down quilt.
BACKS AND ARMRESTS: padded with polyurethane foam with a polyester pad and covered with a 100% down quilt. Available in two heights: H. 66 cm and H. 78 cm.
FEET: in black plastic.
UPHOLSTERY: Not available in Fintapelle Vintage/Intreccio (Extra) and Cartagena (Start). Removable cover in the fabric version. Available with or without quilting.
CUSTOMER FABRIC: Customer fabric does not include leather. For the required linear metres, see the price list.

STRUCTURE: construite en sapin massif et contreplaqué et rembourrée en polyuréthane expansé. Parties secondaires et non structurelles en panneaux de fibres de bois.
ASSISES: rembourrés en polyuréthane expansé à densité différenciée et recouverts d'un matelassage en plume (100%).
DOSSIERS ET ACCOUDOIRS: rembourrés en polyuréthane expansé avec tampon en polyester et recouverts d'un matelassage en plume (100%). Disponibles en deux hauteurs : H. 66 cm et H. 78 cm.
PIEDS: en plastique noir.
REVÊTEMENT: Non disponible dans Fintapelle vintage/Intreccio (catégorie Extra) et dans Cartagena (catégorie Start). Tissu déhoussable. Disponible avec ou sans matelassage.
TISSU CLIENT: le tissu client n'inclut pas les cuirs. Pour le métrage, voir le tarif.

STRUKTUR: Fichte massiv und kaschierter Stoff, mit Polyurethanschaum. Nicht Teile aus Holzfaserverplatten.
SITZFLÄCHEN: Polsterung aus Polyurethanschaum mit unterschiedlicher Dichte, mit 100 % Außensteppung aus Daunen.
RÜCKENLEHNEN UND ARMLEHNEN: Polsterung aus Polyurethanschaum mit Polyesterpolster und 100 % Außensteppung aus Daunen. In zwei Höhen erhältlich: H. 66 cm und H. 78 cm.
FÜSSE: aus schwarzem Kunststoff.
ABDECKUNG: Nicht verfügbar im Fintapelle Vintage/Intreccio (Extra) und im Cartagena (Start). Vollständig abziehbar in der Stoffversion. Erhältlich mit oder ohne Steppung.
EIGENSTOFF: Vom Kunden bereitgestellter Stoff umfasst kein Leder. Für den benötigten Stoffverbrauch siehe Preisliste.

ESTRUCTURA: construido en abeto macizo y multicapa y revestido con poliuretano expandido. Partes secundarias y no estructurales en paneles de fibra de madera.
ASIENTOS: acolchado en poliuretano expandido de densidad diferenciada y revestidos externamente con acolchado de pluma (100%).
RESPALDOS Y BRAZOS: acolchado en poliuretano expandido con relleno de poliéster y revestidos externamente con acolchado de pluma (100%). Disponibles en dos alturas: H. 66 cm y H. 78 cm.
PATAS: en plástico negro.
REVESTIMIENTO: No disponible en Fintapelle Vintage/Intreccio (Extra) ni en Cartagena (Start). Desenfundable en la versión tejido. Disponible con o sin punteado.
TELA CLIENTE: El tejido proporcionado por el cliente no incluye pieles. Para el metraje, consulte la lista de precios.

TRAMA

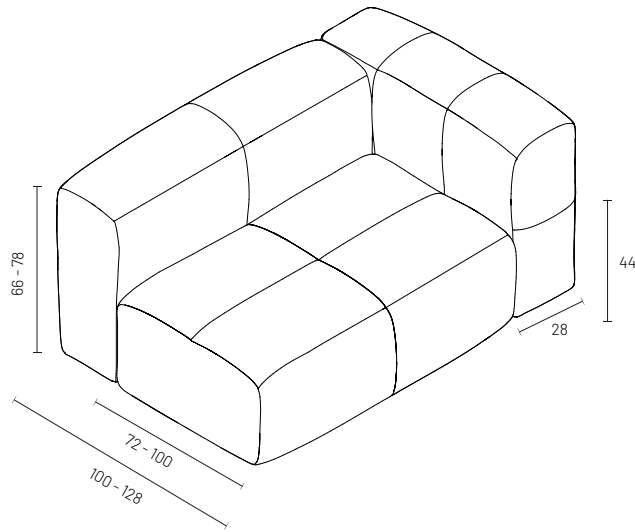
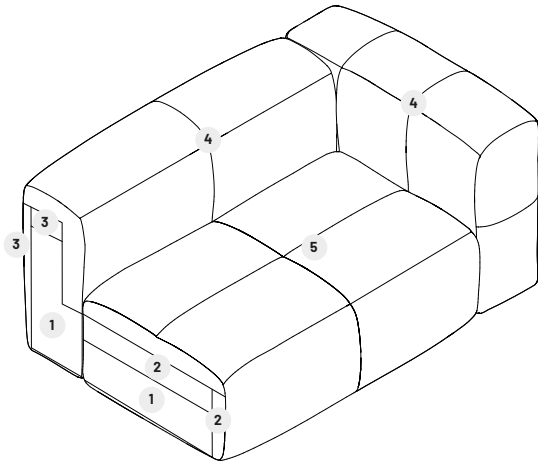

abete massello e multistrato
 solid spruce and plywood
 sapin massif et contreplaqué
 Fichte massiv und kaschierter Stoff
 abeto macizo y multicapa

1

poliuretano D32 ALX
 polyurethane D32 ALX
 polyuréthane D32 ALX
 Polyurethan D32 ALX
 poliuretano D32 ALX

2

poliuretano D40 T
 polyurethane D40 T
 polyuréthane D40 T
 Polyurethan D40 T
 poliuretano D40 T

3

poliuretano D21 SH3 rivestito resinato GR 200 + VELL
 polyurethane D21 SH3 covered with GR 200 + VELL resin coating
 polyuréthane D21 SH3 revêtu de résiné GR 200 + VELL
 Polyurethan D21 SH3 mit Harzbeschichtung GR. 200 + VELL bezogen
 poliuretano D21 SH3 recubierto con resina GR 200 + VELL

4

poliuretano D35 M rivestito resinato GR 200 + VELL
 polyurethane D35 M covered with GR 200 + VELL resin coating
 polyuréthane D35 M revêtu de résiné GR 200 + VELL
 Polyurethan D35 M mit Harzbeschichtung GR. 200 + VELL bezogen
 poliuretano D35 M recubierto con resina GR 200 + VELL

5

SCHIENA E BRACCIOLO BASSI
 LOW BACKREST AND ARMREST
 DOSSIER ET ACCOUDOIR BAS
 NIEDRIGE RÜCKEN-UND ARMLEHNNE
 RESPALDO Y BRAZO BAJOS

SCHIENA E BRACCIOLO ALTI
 HIGH BACKREST AND ARMREST
 DOSSIER ET ACCOUDOIR HAUTS
 HOHE RÜCKEN-UND ARMLEHNNE
 RESPALDO Y BRAZO ALTOS

SCHIENA ALTA E BRACCIOLO BASSO
 HIGH BACKREST WITH LOW ARMREST
 DOSSIER HAUT ET ACCOUDOIR BAS
 HOHE RÜCKEN-UND NIEDRIGE ARMLEHNNE
 RESPALDO ALTO Y BRAZO BAJO

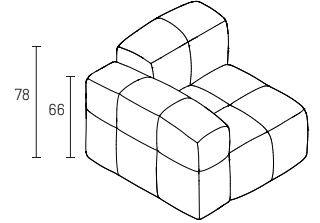
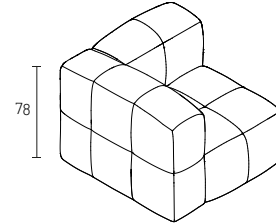
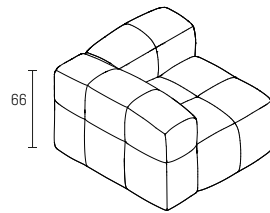

	<p>SCHIENALI E BRACCIOLO BACKRESTS AND ARMRESTS DOSSIERS ET ACCOUDOIRS RÜCKENLEHNEN UND ARMLEHNEN RESPALDOS Y REPOSABRAZOS</p>	<p>SEDUTA SEAT ASSISE SITZFLÄCHE ASIENTO</p>
<p>SFODERABILE REMOVABLE DÉHOUSSABLE ABZIEHBAR DESENFUNDABLE</p>	<p>fabric</p>	<p>fabric</p>
<p>NON SFODERABILE NON REMOVABLE NON DÉHOUSSABLE NICHT ABZIEHBAR NO DESENFUNDABLE</p>	-	-

modulo laterale 1 posto, trapuntatura P. 34 cm
 1-seat side element, quilting D. 34 cm
 module latéral 1 place, matelassage T. 34 cm
 seitliches Modul 1 Sitz, Steppung T. 34 cm
 módulo lateral 1 plaza, punteado P. 34 cm

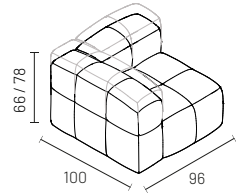

	L W	H H	P D	CODICE CODE	Basic	Start	Extra	Light	Super	t-cliente com-fabric	ml l.mt.	m ³ kg
schiena e bracciolo bassi dx rh low backrest and armrest dossier et accoudoir bas droite niedrige Rücken-und Armlehne re. respaldo y brazo bajos, dchos	96	66	100	DI01TTBAD11	1.429	1.549	1.836	1.924	2.159	1.279	8	0,66 39
schiena e bracciolo bassi sx lh low backrest and armrest dossier et accoudoir bas gauche niedrige Rücken-und Armlehne le. respaldo y brazo bajos, izdos	96	66	100	DI01TTBAS11	1.429	1.549	1.836	1.924	2.159	1.279	8	0,66 39
schiena e bracciolo alti dx rh high backrest and armrest dossier et accoudoir hauts droite hohe Rücken-und Armlehne re. respaldo y brazo altos, dchos	96	78	100	DI01TTBAD22	1.470	1.590	1.881	1.969	2.204	1.324	8	0,73 44
schiena e bracciolo alti sx lh high backrest and armrest dossier et accoudoir hauts gauche hohe Rücken-und Armlehne le. respaldo y brazo altos, izdos	96	78	100	DI01TTBAS22	1.470	1.590	1.881	1.969	2.204	1.324	8	0,73 44
schiena alta e bracciolo basso dx rh high backrest with low armrest dossier haut et accoudoir bas droite hohe Rücken-und niedrige Armlehne re. respaldo alto y brazo bajo, dchos	96	78	100	DI01TTBAD12	1.447	1.567	1.856	1.944	2.179	1.299	8	0,69 41
schiena alta e bracciolo basso sx lh high backrest with low armrest dossier haut et accoudoir bas gauche hohe Rücken-und niedrige Armlehne li. respaldo alto y brazo bajo, izdos	96	78	100	DI01TTBAS12	1.447	1.567	1.856	1.944	2.179	1.299	8	0,69 41

modulo laterale 1 posto large, trapuntatura P. 34 cm
 1-seat large side element, quilting D. 34 cm
 module latéral 1 place grand, matelassage T. 34 cm
 großes seitliches Modul 1 Sitz, Steppung T. 34 cm
 módulo lateral grande 1 plaza, punteado P. 34 cm

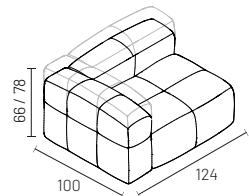

schiena e bracciolo bassi dx rh low backrest and armrest dossier et accoudoir bas droite niedrige Rücken-und Armlehne re. respaldo y brazo bajos, dchos	124	66	100	DI01TTBED11	1.571	1.694	1.999	2.089	2.330	1.428	8,2	0,69 44
schiena e bracciolo bassi sx lh low backrest and armrest dossier et accoudoir bas gauche niedrige Rücken-und Armlehne le. respaldo y brazo bajos, izdos	124	66	100	DI01TTBES11	1.571	1.694	1.999	2.089	2.330	1.428	8,2	0,69 44
schiena e bracciolo alti dx rh high backrest and armrest dossier et accoudoir hauts droite hohe Rücken-und Armlehne re. respaldo y brazo altos, dchos	124	78	100	DI01TTBED22	1.612	1.735	2.044	2.134	2.375	1.473	8,2	0,77 49
schiena e bracciolo alti sx lh high backrest and armrest dossier et accoudoir hauts gauche hohe Rücken-und Armlehne le. respaldo y brazo altos, izdos	124	78	100	DI01TTBES22	1.612	1.735	2.044	2.134	2.375	1.473	8,2	0,77 49
schiena alta e bracciolo basso dx rh high backrest with low armrest dossier haut et accoudoir bas droite hohe Rücken-und niedrige Armlehne re. respaldo alto y brazo bajo, dchos	124	78	100	DI01TTBED12	1.589	1.712	2.019	2.109	2.350	1.448	8,2	0,73 46
schiena alta e bracciolo basso sx lh high backrest with low armrest dossier haut et accoudoir bas gauche hohe Rücken-und niedrige Armlehne li. respaldo alto y brazo bajo, izdos	124	78	100	DI01TTBES12	1.589	1.712	2.019	2.109	2.350	1.448	8,2	0,73 46

modulo laterale 2 posti, trapuntatura P. 34 cm
 2-seat side element, quilting D. 34 cm
 module latéral 2 places, matelassage T. 34 cm
 seitliches Modul 2 Sitze, Steppung T. 34 cm
 módulo lateral 2 plazas, punteado P. 34 cm

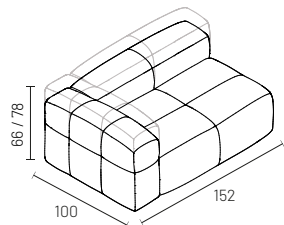

	L W	H H	P D	CODICE CODE	Basic	Start	Extra	Light	Super	t-cliente com-fabric	ml l.mt.	m³ kg
schiena e bracciolo bassi dx rh low backrest and armrest dossier et accoudoir bas droite niedrige Rücken-und Armlehne re. respaldo y brazo bajos, dchos	152	66	100	DI01TTBAD11	1.890	2.017	2.359	2.452	2.702	1.767	8,5	0,85 45
schiena e bracciolo bassi sx lh low backrest and armrest dossier et accoudoir bas gauche niedrige Rücken-und Armlehne le. respaldo y brazo bajos, izdos	152	66	100	DI01TTBAS11	1.890	2.017	2.359	2.452	2.702	1.767	8,5	0,85 45
schiena e bracciolo alti dx rh high backrest and armrest dossier et accoudoir hauts droite hohe Rücken-und Armlehne re. respaldo y brazo altos, dchos	152	78	100	DI01TTBAD22	1.929	2.057	2.403	2.496	2.745	1.810	8,5	0,96 50
schiena e bracciolo alti sx lh high backrest and armrest dossier et accoudoir hauts gauche hohe Rücken-und Armlehne le. respaldo y brazo altos, izdos	152	78	100	DI01TTBAS22	1.929	2.057	2.403	2.496	2.745	1.810	8,5	0,96 50
schiena alta e bracciolo basso dx rh high backrest with low armrest dossier haut et accoudoir bas droite hohe Rücken-und niedrige Armlehne re. respaldo alto y brazo bajo, dchos	152	78	100	DI01TTBAD12	1.908	2.035	2.379	2.472	2.722	1.787	8,5	0,9 47
schiena alta e bracciolo basso sx lh high backrest with low armrest dossier haut et accoudoir bas gauche hohe Rücken-und niedrige Armlehne ll. respaldo alto y brazo bajo, izdos	152	78	100	DI01TTBAS12	1.908	2.035	2.379	2.472	2.722	1.787	8,5	0,9 47

modulo centrale 1 posto, trapuntatura P. 34 cm
 1-seat central element, quilting D. 34 cm
 module central 1 place, matelassage T. 34 cm
 Zentralmodul 1 Sitzig, Steppung T. 34 cm
 módulo central 1 plaza, punteado P. 34 cm

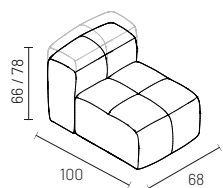

schiena bassa low backrest dossier bas niedrige Rückenlehne respaldo bajo	68	66	100	DI01TTCA01	991	1.063	1.248	1.301	1.442	914	4,8	0,48 32
schiena alta rh high backrest dossier haut droite hohe Rückenlehne re. respaldo alto dh	68	78	100	DI01TTCA02	1.010	1.082	1.269	1.322	1.463	935	4,8	0,53 36

modulo centrale 1 posto large, trapuntatura P. 34 cm
 1-seat large central element, quilting D. 34 cm
 module central 1 place grand, matelassage T. 34 cm
 großes Zentralmodul 1 Sitz, Steppung T. 34 cm
 módulo central grande 1 plaza, punteado P. 34 cm

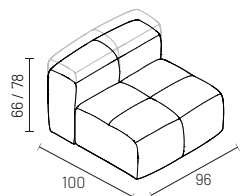

schiena bassa low backrest dossier bas niedrige Rückenlehne respaldo bajo	96	66	100	DI01TTCE01	1.120	1.197	1.401	1.457	1.606	1.045	5,1	0,62 39
schiena alta rh high backrest dossier haut droite hohe Rückenlehne re. respaldo alto dh	96	78	100	DI01TTCE02	1.140	1.216	1.422	1.478	1.627	1.066	5,1	0,74 41

modulo centrale 2 posti, trapuntatura P. 34 cm

2-seat central element, quilting D. 34 cm

module central 2 places, matelassage T. 34 cm

Zentralmodul 2 Sitze, Steppung T. 34 cm

módulo central 2 plazas, punteado P. 34 cm

L W	H H	P D	CODICE CODE	Basic	Start	Extra	Light	Super	t-cliente com-fabric	ml l.mt.	m ³ kg
--------	--------	--------	----------------	-------	-------	-------	-------	-------	-------------------------	-------------	----------------------

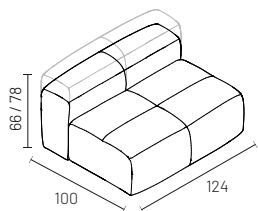

schiena bassa low backrest dossier bas niedrige Rückenlehne respaldo bajo	124	66	100	DI01TTCB01	1.323	1.404	1.633	1.693	1.851	1.257	5,4	0,69 44
schiena alta rh high backrest dossier haut droite hohe Rückenlehne re. respaldo alto dh	124	78	100	DI01TTCB02	1.342	1.423	1.654	1.714	1.872	1.278	5,4	0,77 49

modulo centrale 1 posto senza schiena, trapuntatura P. 34 cm

1-seat central element without backrest, quilting D. 34 cm

module central 1 place sans dossier, matelassage T. 34 cm

Zentralmodul 1 Sitz ohne Rückenlehne, Steppung T. 34 cm

módulo central 1 plaza sin respaldo, punteado P. 34 cm

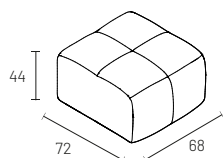

	68	44	72	DI01TTCA000	605	662	791	833	945	527	3,8	0,22 20
--	----	----	----	-------------	-----	-----	-----	-----	-----	-----	-----	------------

modulo centrale 1 posto large senza schiena, trapuntatura P. 34 cm

1-seat large central element without backrest, quilting D. 34 cm

module central 1 place grand sans dossier, matelassage T. 34 cm

großes Zentralmodul 1 Sitz ohne Rückenlehne, Steppung T. 34 cm

módulo central grande 1 plaza sin respaldo, punteado P. 34 cm

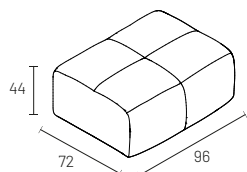

	96	44	72	DI01TTCE000	712	774	919	964	1.084	633	4,1	0,29 24
--	----	----	----	-------------	-----	-----	-----	-----	-------	-----	-----	------------

modulo centrale 2 posti senza schiena, trapuntatura P. 34 cm

2-seat central element without backrest, quilting D. 34 cm

module central 2 places sans dossier, matelassage T. 34 cm

Zentralmodul 2 Sitze ohne Rückenlehne, Steppung T. 34 cm

módulo central 2 plazas sin respaldo, punteado P. 34 cm

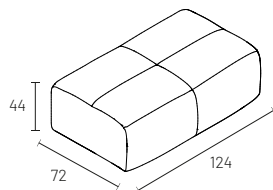

	124	44	72	DI01TTCB000	860	926	1.091	1.139	1.268	784	4,4	0,38 30
--	-----	----	----	-------------	-----	-----	-------	-------	-------	-----	-----	------------

TRAMA

moduli | units | modules | module | módulos

modulo centrale senza schiena, trapuntatura P. 34 cm
 central element without backrest, quilting D. 34 cm
 module central sans dossier, matelassage T. 34 cm
 Zentralmodul ohne Rückenlehne, Steppung T. 34 cm
 módulo central sin respaldo, punteado P. 34 cm

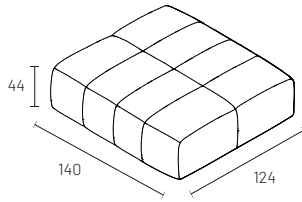

L W	H H	P D	CODICE CODE	Basic	Start	Extra	Light	Super	t-cliente com-fabric	ml l.mt.	m ³ kg
--------	--------	--------	----------------	-------	-------	-------	-------	-------	-------------------------	-------------	----------------------

124	44	140	DI01TTCF000	1.255	1.339	1.423	1.479	1.628	1.175	5,6	0,75 50
-----	----	-----	-------------	-------	-------	-------	-------	-------	-------	-----	------------

modulo pentagono centrale, trapuntatura P. 34 cm
 pentagonal central element, quilting D. 34 cm
 module pentagonal central, matelassage T. 34 cm
 pentagonales Zentralmodul, Steppung T. 34 cm
 módulo pentagonal central, punteado P. 34 cm

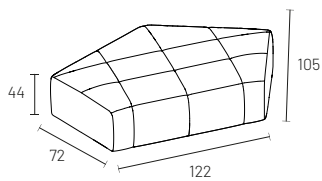

122	44	105	DI01TTN0000	1.666	1.765	2.050	2.123	2.317	1.591	6,6	0,6 38
-----	----	-----	-------------	-------	-------	-------	-------	-------	-------	-----	-----------

modulo pentagono centrale con schiene, trapuntatura P. 34 cm
 pentagonal central element with backrests, quilting D. 34 cm
 module pentagonal central avec dossiers, matelassage T. 34 cm
 pentagonales Zentralmodul mit Rückenlehne, Steppung T. 34 cm
 módulo pentagonal central con respaldo, punteado P. 34 cm

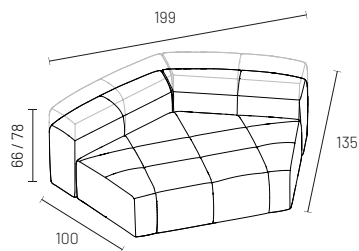

schiena bassa
 low backrest
 dossier bas
 niedrige Rückenlehne
 respaldo bajo

schiena alta
 rh high backrest
 dossier haut droite
 hohe Rückenlehne re.
 respaldo alto dh

199	66	135	DI01TTN001	2.520	2.664	3.089	3.195	3.476	2.420	9,6	1,4 74
199	78	135	DI01TTN002	2.560	2.704	3.132	3.238	3.520	2.464	9,6	1,6 85

modulo pentagono laterale con schiene, trapuntatura P. 34 cm
 pentagonal side element with backrests, quilting D. 34 cm
 module pentagonal latéral avec dossiers, matelassage T. 34 cm
 pentagonales seitliches Modul mit Rückenlehne, Steppung T. 34 cm
 módulo pentagonal lateral con respaldo, punteado P. 34 cm

L W	H H	P D	CODICE CODE	Basic	Start	Extra	Light	Super	t-cliente com-fabric	ml l.mt.	m ³ kg
--------	--------	--------	----------------	-------	-------	-------	-------	-------	-------------------------	-------------	----------------------

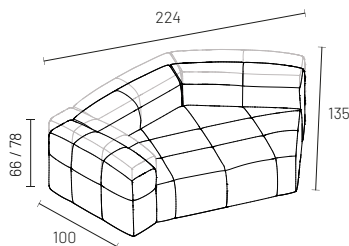

			schiena e bracciolo bassi dx rh low backrest and armrest dossier et accoudoir bas droite niedrige Rücken-und Armlehne re. respaldo y brazo bajos, dchos	224	66	135	DI01TTOOD11	2.990	3.185	3.718	3.861	4.242	2.812	13	1,54 81
			schiena e bracciolo bassi sx lh low backrest and armrest dossier et accoudoir bas gauche niedrige Rücken-und Armlehne le. respaldo y brazo bajos, izdos	224	66	135	DI01TTOOS11	2.990	3.185	3.718	3.861	4.242	2.812	13	1,54 81
			schiena e bracciolo alti dx rh high backrest and armrest dossier et accoudoir hauts droite hohe Rücken-und Armlehne re. respaldo y brazo altos, dchos	224	78	135	DI01TTOOD22	3.051	3.246	3.785	3.928	4.309	2.879	13	1,74 92
			schiena e bracciolo alti sx lh high backrest and armrest dossier et accoudoir hauts gauche hohe Rücken-und Armlehne le. respaldo y brazo altos, izdos	224	78	135	DI01TTOOS22	3.051	3.246	3.785	3.928	4.309	2.879	13	1,74 92
			schiena alta e bracciolo basso dx rh high backrest with low armrest dossier haut et accoudoir bas droite hohe Rücken-und niedrige Armlehne re. respaldo alto y brazo bajo, dchos	224	78	135	DI01TTOOD12	3.026	3.221	3.757	3.900	4.282	2.852	13	1,64 86
			schiena alta e bracciolo basso sx lh high backrest with low armrest dossier haut et accoudoir bas gauche hohe Rücken-und niedrige Armlehne li. respaldo alto y brazo bajo, izdos	224	78	135	DI01TTOOS12	3.026	3.221	3.757	3.900	4.282	2.852	13	1,64 86

modulo pentagono terminale con 1 schiena, trapuntatura P. 34 cm
 pentagonal end element with 1 backrest, quilting D. 34 cm
 module pentagonal terminal avec 1 dossier, matelassage T. 34 cm
 pentagonales Abschlussmodul mit 1 Rückenlehne, Steppung T. 34 cm
 módulo pentagonal terminal con 1 respaldo, punteado P. 34 cm

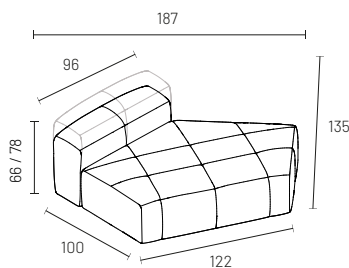

raffigurato dx
 rh in the figure
 illustré à droite
 rechts dargestellt
 representado dcho

			schiena bassa dx rh low backrest dossier bas droite niedrige Rückenlehne re. respaldo bajo dcho	187	66	135	DI01TTPOD01	2.021	2.141	2.487	2.575	2.810	1.930	8	1,3 66
			schiena bassa sx lh low backrest dossier bas gauche niedrige Rückenlehne li. respaldo bajo izdo	187	66	135	DI01TTPOS01	2.021	2.141	2.487	2.575	2.810	1.930	8	1,3 66
			schiena alta dx rh high backrest dossier haut droite hohe Rückenlehne re. respaldo alto dh	187	78	135	DI01TTPOD02	2.041	2.161	2.509	2.597	2.832	1.952	8	1,5 78
			schiena alta sx lh high backrest dossier haut gauche hohe Rückenlehne li. respaldo alto iz	187	78	135	DI01TTPOS02	2.041	2.161	2.509	2.597	2.832	1.952	8	1,5 78

TRAMA

moduli | units | modules | module | módulos

angolo, trapuntatura P. 34 cm
corner element, quilting D. 34 cm
angle, matelassage T. 34 cm
Eckelement, Steppung T. 34 cm
elemento ángulo, punteado P. 34 cm

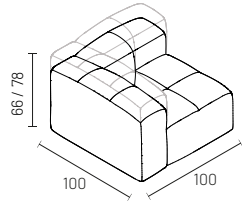

L W	H H	P D	CODICE CODE	Basic	Start	Extra	Light	Super	t-cliente com-fabric	ml l.mt.	m ³ kg
--------	--------	--------	----------------	-------	-------	-------	-------	-------	-------------------------	-------------	----------------------

schiena basse low backrests dossiers bas niedrige Rückenlehnen respaldos bajos				100	66	100	DI01TTF011	1.457	1.591	1.896	1.994	2.255	1.276	8,9	0,66 39
schiena alte high backrests dossiers hauts hohe Rückenlehnen respaldos altos				100	78	100	DI01TTF022	1.498	1.631	1.941	2.039	2.300	1.321	8,9	0,73 44

chaise longue large, trapuntatura P. 34 cm
large chaise longue, quilting D. 34 cm
chaise longue grande, matelassage T. 34 cm
große chaise longue, Steppung T. 34 cm
chaise longue grande, punteado P. 34 cm

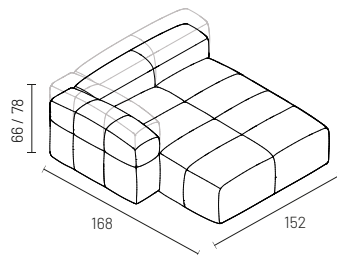

schiena e bracciolo bassi dx rh low backrest and armrest dossier et accoudoir bas droite niedrige Rücken-und Armlehne re. respaldo y brazo bajos, dchos				152	66	168	DI01TTIOD11	2.193	2.349	2.756	2.870	3.175	2.031	10,9	1,7 90
schiena e bracciolo bassi sx lh low backrest and armrest dossier et accoudoir bas gauche niedrige Rücken-und Armlehne le. respaldo y brazo bajos, izdos				152	66	168	DI01TTIOS11	2.193	2.349	2.756	2.870	3.175	2.031	10,9	1,7 90
schiena e bracciolo alti dx rh high backrest and armrest dossier et accoudoir hauts droite hohe Rücken-und Armlehne re. respaldo y brazo altos, dchos				152	78	168	DI01TTIOD22	2.234	2.390	2.546	2.650	2.927	2.076	10,9	2 98
schiena e bracciolo alti sx lh high backrest and armrest dossier et accoudoir hauts gauche hohe Rücken-und Armlehne le. respaldo y brazo altos, izdos				152	78	168	DI01TTIOS22	2.234	2.390	2.546	2.650	2.927	2.076	10,9	2 98
schiena alta e bracciolo basso dx rh high backrest with low armrest dossier haut et accoudoir bas droite hohe Rücken-und niedrige Armlehne re. respaldo alto y brazo bajo, dchos				152	78	168	DI01TTIOD12	2.212	2.368	2.524	2.628	2.906	2.052	10,9	1,85 94
schiena alta e bracciolo basso sx lh high backrest with low armrest dossier haut et accoudoir bas gauche hohe Rücken-und niedrige Armlehne li. respaldo alto y brazo bajo, izdos				152	78	168	DI01TTIOS12	2.212	2.368	2.524	2.628	2.906	2.052	10,9	1,85 94

Moduli rappresentati sx se non specificato diversamente. | Units represented as lh unless otherwise specified. | Modules représentés à gauche sauf indication contraire. | Module links dargestellt, sofern nicht anders angegeben. | Módulos representados izquierdos, excepto indicación contraria.

modulo laterale 1 posto large, trapuntatura P. 48 cm
 1-seat large side element, quilting D. 48 cm
 module latéral 1 place grand, matelassage T. 48 cm
 großes seitliches Modul 1 Sitz, Steppung T. 48 cm
 módulo lateral grande 1 plazo, punteado P. 48 cm

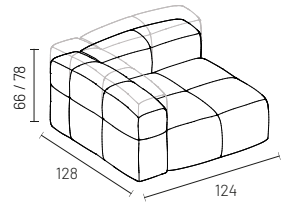

	L W	H H	P D	CODICE CODE	Basic	Start	Extra	Light	Super	t-cliente com-fabric	ml l.mt.	m³ kg
schiena e bracciolo bassi dx rh low backrest and armrest dossier et accouoir bas droite niedrige Rücken-und Armlehne re. respaldo y brazo bajos, dchos	124	66	128	DI01TUBED11	1.809	1.923	2.241	2.324	2.547	1.711	7,6	0,85 45
schiena e bracciolo bassi sx lh low backrest and armrest dossier et accouoir bas gauche niedrige Rücken-und Armlehne le. respaldo y brazo bajos, izdos	124	66	128	DI01TUBES11	1.809	1.923	2.241	2.324	2.547	1.711	7,6	0,85 45
schiena e bracciolo alti dx rh high backrest and armrest dossier et accouoir hauts droite hohe Rücken-und Armlehne re. respaldo y brazo altos, dchos	124	78	128	DI01TUBED22	1.846	1.960	2.281	2.365	2.588	1.752	7,6	0,96 50
schiena e bracciolo alti sx lh high backrest and armrest dossier et accouoir hauts gauche hohe Rücken-und Armlehne le. respaldo y brazo altos, izdos	124	78	128	DI01TUBES22	1.846	1.960	2.281	2.365	2.588	1.752	7,6	0,96 50
schiena alta e bracciolo basso dx rh high backrest with low armrest dossier haut et accouoir bas droite hohe Rücken-und niedrige Armlehne re. respaldo alto y brazo bajo, dchos	124	78	128	DI01TUBED12	1.827	1.941	2.260	2.344	2.567	1.731	7,6	0,9 47
schiena alta e bracciolo basso sx lh high backrest with low armrest dossier haut et accouoir bas gauche hohe Rücken-und niedrige Armlehne li. respaldo alto y brazo bajo, izdos	124	78	128	DI01TUBES12	1.827	1.941	2.260	2.344	2.567	1.731	7,6	0,9 47

modulo laterale 2 posti, trapuntatura P. 48 cm
 2-seat side element, quilting D. 48 cm
 module latéral 2 places, matelassage T. 48 cm
 seitliches Modul 2 Sitze, Steppung T. 48 cm
 módulo lateral 2 plazos, punteado P. 48 cm

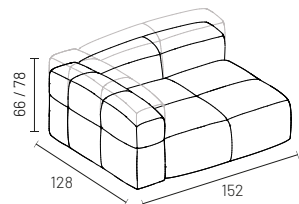

schiena e bracciolo bassi dx rh low backrest and armrest dossier et accouoir bas droite niedrige Rücken-und Armlehne re. respaldo y brazo bajos, dchos	152	66	128	DI01TUBBD11	2.095	2.218	2.575	2.665	2.906	2.004	8,2	0,9 47
schiena e bracciolo bassi sx lh low backrest and armrest dossier et accouoir bas gauche niedrige Rücken-und Armlehne le. respaldo y brazo bajos, izdos	152	66	128	DI01TUBBS11	2.095	2.218	2.575	2.665	2.906	2.004	8,2	0,9 47
schiena e bracciolo alti dx rh high backrest and armrest dossier et accouoir hauts droite hohe Rücken-und Armlehne re. respaldo y brazo altos, dchos	152	78	128	DI01TUBBD22	2.135	2.258	2.619	2.709	2.949	2.047	8,2	1 52
schiena e bracciolo alti sx lh high backrest and armrest dossier et accouoir hauts gauche hohe Rücken-und Armlehne le. respaldo y brazo altos, izdos	152	78	128	DI01TUBBS22	2.135	2.258	2.619	2.709	2.949	2.047	8,2	1 52
schiena alta e bracciolo basso dx rh high backrest with low armrest dossier haut et accouoir bas droite hohe Rücken-und niedrige Armlehne re. respaldo alto y brazo bajo, dchos	152	78	128	DI01TUBBD12	2.111	2.234	2.593	2.683	2.924	2.022	8,2	0,96 50
schiena alta e bracciolo basso sx lh high backrest with low armrest dossier haut et accouoir bas gauche hohe Rücken-und niedrige Armlehne li. respaldo alto y brazo bajo, izdos	152	78	128	DI01TUBBS12	2.111	2.234	2.593	2.683	2.924	2.022	8,2	0,96 50

modulo centrale 1 posto large, trapuntatura P. 48 cm

1-seat large central element, quilting D. 48 cm

module central 1 place grand, matelassage T. 48 cm

großes Zentralmodul 1 Sitz, Steppung T. 48 cm

módulo central grande 1 plazo, punteado P. 48 cm

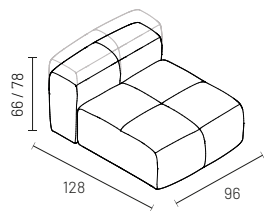

schiena bassa

low backrest

dossier bas

niedrige Rückenlehne

respaldo bajo

schiena alta

rh high backrest

dossier haut droite

hohe Rückenlehne re.

respaldo alto dh

L W	H H	P D	CODICE CODE	Basic	Start	Extra	Light	Super	t-cliente com-fabric	ml l.mt.	m ³ kg
--------	--------	--------	----------------	-------	-------	-------	-------	-------	-------------------------	-------------	----------------------

96	66	128	DI01TUCE01	1.285	1.372	1.605	1.669	1.839	1.201	5,8	0,8 42
----	----	-----	------------	-------	-------	-------	-------	-------	-------	-----	-----------

96	78	128	DI01TUCE02	1.304	1.391	1.626	1.690	1.860	1.222	5,8	0,96 50
----	----	-----	------------	-------	-------	-------	-------	-------	-------	-----	------------

modulo centrale 2 posti, trapuntatura P. 48 cm

2-seat central element, quilting D. 48 cm

module central 2 places, matelassage T. 48 cm

Zentralmodul 2 Sitze, Steppung T. 48 cm

módulo central 2 plazos, punteado P. 48 cm

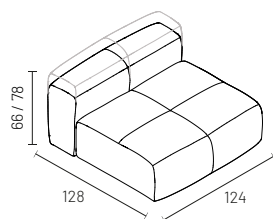

schiena bassa

low backrest

dossier bas

niedrige Rückenlehne

respaldo bajo

schiena alta

rh high backrest

dossier haut droite

hohe Rückenlehne re.

respaldo alto dh

124	66	128	DI01TUCB01	1.575	1.668	1.937	2.006	2.187	1.505	6,2	1 53
-----	----	-----	------------	-------	-------	-------	-------	-------	-------	-----	---------

124	78	128	DI01TUCB02	1.594	1.687	1.959	2.027	2.209	1.527	6,2	1,2 60
-----	----	-----	------------	-------	-------	-------	-------	-------	-------	-----	-----------

modulo centrale senza schiena 1 posto large, trapuntatura P. 48 cm

1-seat large central element without backrest, quilting D. 48 cm

module central 1 place grand sans dossier, matelassage T. 48 cm

großes Zentralmodul 1 Sitz ohne Rückenlehne, Steppung T. 48 cm

módulo central grande 1 plazo sin respaldo, punteado P. 48 cm

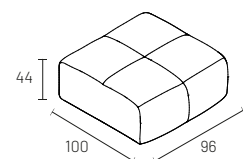

96	44	100	DI01TUCE000	843	900	1.052	1.094	1.206	788	3,8	0,42 24
----	----	-----	-------------	-----	-----	-------	-------	-------	-----	-----	------------

modulo centrale senza schiena 2 posti large, trapuntatura P. 48 cm

2-seat central large element without backrest, quilting D. 48 cm

module central 2 places grand sans dossier, matelassage T. 48 cm

großes Zentralmodul 2 Sitze ohne Rückenlehne, Steppung T. 48 cm

módulo central grande 2 plazos sin respaldo, punteado P. 48 cm

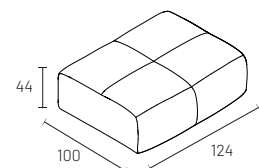

124	44	100	DI01TUCB000	1.056	1.122	1.306	1.355	1.484	1.000	4,4	0,54 28
-----	----	-----	-------------	-------	-------	-------	-------	-------	-------	-----	------------

TRAMA

moduli | units | modules | module | módulos

modulo centrale senza schiena, trapuntatura P. 48 cm
 central element without backrest, quilting D. 48 cm
 module central sans dossier, matelassage T. 48 cm
 Zentralmodul ohne Rückenlehne, Steppung T. 48 cm
 módulo central sin respaldo, punteado P. 48 cm

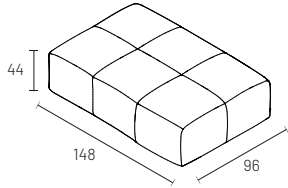

L W	H H	P D	CODICE CODE	Basic	Start	Extra	Light	Super	t-cliente com-fabric	ml l.mt.	m³ kg
--------	--------	--------	----------------	-------	-------	-------	-------	-------	-------------------------	-------------	----------

96	44	148	DI01TUCF000	1.209	1.293	1.377	1.433	1.582	1.125	5,6	0,61 33
----	----	-----	-------------	-------	-------	-------	-------	-------	-------	-----	------------

modulo centrale senza schiena, trapuntatura P. 48 cm
 central element without backrest, quilting D. 48 cm
 module central sans dossier, matelassage T. 48 cm
 Zentralmodul ohne Rückenlehne, Steppung T. 48 cm
 módulo central sin respaldo, punteado P. 48 cm

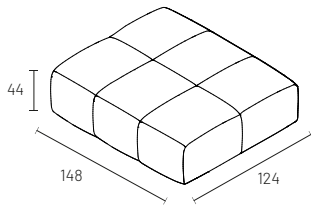

124	44	148	DI01TUCG000	1.331	1.415	1.499	1.555	1.704	1.259	5,6	0,8 42
-----	----	-----	-------------	-------	-------	-------	-------	-------	-------	-----	-----------

angolo large, trapuntatura P. 48 cm
 large corner element, quilting D. 48 cm
 grand angle, matelassage T. 48 cm
 große ECKelement, Steppung T. 48 cm
 elemento ángulo grande, punteado P. 48 cm

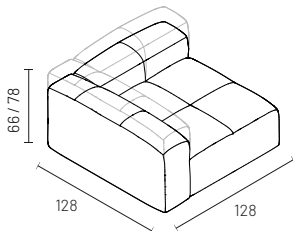

schiene basse low backrests dossiers bas niedrige Rückenlehnen respaldos bajos	128	66	128	DI01TUF011	1.771	1.891	2.212	2.300	2.535	1.655	8	1,02 53
schiene alte high backrests dossiers hauts hohe Rückenlehnen respaldos altos	128	78	128	DI01TUF022	1.812	1.932	2.257	2.345	2.580	1.700	8	1,23 58

chaise longue, trapuntatura P. 48 cm
 chaise longue, quilting D. 48 cm
 chaise longue, matelassage T. 48 cm
 chaise longue, Steppung T. 48 cm
 chaise longue, punteado P. 48 cm

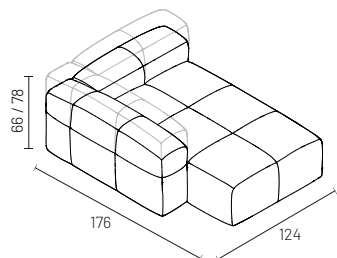

	L W	H H	P D	CODICE CODE	Basic	Start	Extra	Light	Super	t-cliente com-fabric	ml l.mt.	m³ kg
schiena e bracciolo bassi dx rh low backrest and armrest dossier et accoudoir bas droite niedrige Rücken-und Armlehne re. respaldo y brazo bajos, dchos	124	66	176	DI01TUI0D11	2.210	2.373	2.791	2.911	3.230	2.031	10,4	1,45 76
schiena e bracciolo bassi sx lh low backrest and armrest dossier et accoudoir bas gauche niedrige Rücken-und Armlehne le. respaldo y brazo bajos, izdos	124	66	176	DI01TUI0S11	2.210	2.373	2.791	2.911	3.230	2.031	10,4	1,45 76
schiena e bracciolo alti dx rh high backrest and armrest dossier et accoudoir hauts droite hohe Rücken-und Armlehne re. respaldo y brazo altos, dchos	124	78	176	DI01TUI0D22	2.251	2.414	2.836	2.955	3.275	2.076	10,4	1,72 88
schiena e bracciolo alti sx lh high backrest and armrest dossier et accoudoir hauts gauche hohe Rücken-und Armlehne le. respaldo y brazo altos, izdos	124	78	176	DI01TUI0S22	2.251	2.414	2.836	2.955	3.275	2.076	10,4	1,72 88
schiena alta e bracciolo basso dx rh high backrest with low armrest dossier haut et accoudoir bas droite hohe Rücken-und niedrige Armlehne re. respaldo alto y brazo bajo, dchos	124	78	176	DI01TUI0D12	2.229	2.393	2.812	2.932	3.251	2.052	10,4	1,58 82
schiena alta e bracciolo basso sx lh high backrest with low armrest dossier haut et accoudoir bas gauche hohe Rücken-und niedrige Armlehne ll. respaldo alto y brazo bajo, izdos	124	78	176	DI01TUI0S12	2.229	2.393	2.812	2.932	3.251	2.052	10,4	1,58 82

chaise longue large, trapuntatura P. 48 cm
 large chaise longue, quilting D. 48 cm
 chaise longue grande, matelassage T. 48 cm
 große chaise longue, Steppung T. 48 cm
 chaise longue grande, punteado P. 48 cm

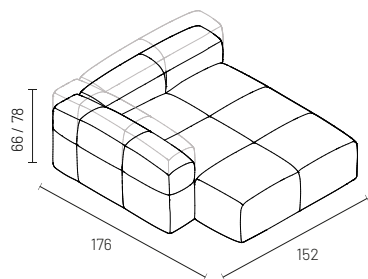

schiena e bracciolo bassi dx rh low backrest and armrest dossier et accoudoir bas droite niedrige Rücken-und Armlehne re. respaldo y brazo bajos, dchos	152	66	176	DI01TUI1D11	2.376	2.532	2.688	2.792	3.069	2.232	10,4	1,78 92
schiena e bracciolo bassi sx lh low backrest and armrest dossier et accoudoir bas gauche niedrige Rücken-und Armlehne le. respaldo y brazo bajos, izdos	152	66	176	DI01TUI1S11	2.376	2.532	2.688	2.792	3.069	2.232	10,4	1,78 92
schiena e bracciolo alti dx rh high backrest and armrest dossier et accoudoir hauts droite hohe Rücken-und Armlehne re. respaldo y brazo altos, dchos	152	78	176	DI01TUI1D22	2.417	2.573	2.729	2.833	3.110	2.277	10,4	2,11 101
schiena e bracciolo alti sx lh high backrest and armrest dossier et accoudoir hauts gauche hohe Rücken-und Armlehne le. respaldo y brazo altos, izdos	152	78	176	DI01TUI1S22	2.417	2.573	2.729	2.833	3.110	2.277	10,4	2,11 101
schiena alta e bracciolo basso dx rh high backrest with low armrest dossier haut et accoudoir bas droite hohe Rücken-und niedrige Armlehne re. respaldo alto y brazo bajo, dchos	152	78	176	DI01TUI1D12	2.395	2.551	2.707	2.811	3.088	2.253	10,4	1,94 96
schiena alta e bracciolo basso sx lh high backrest with low armrest dossier haut et accoudoir bas gauche hohe Rücken-und niedrige Armlehne ll. respaldo alto y brazo bajo, izdos	152	78	176	DI01TUI1S12	2.395	2.551	2.707	2.811	3.088	2.253	8,2	1,94 96

TRAMA

moduli | units | modules | module | módulos

terminale, trapuntatura P. 48 cm
end unit, quilting D. 48 cm
terminal, matelassage T. 48 cm
Abschlusselement, Steppung T. 48 cm
elemento terminal, punteado P. 48 cm

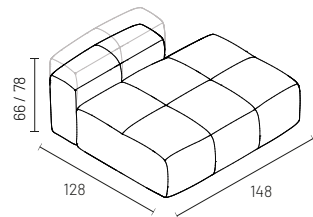

raffigurato dx
rh in the figure
illustré à droite
rechts dargestellt
representado dcho

	L W	H H	P D	CODICE CODE	Basic	Start	Extra	Light	Super	t-cliente com-fabric	ml l.mt.	m ³ kg
schiena bassa dx rh low backrest dossier bas droite niedrige Rückenlehne re. respaldo bajo dcho	148	66	128	DI01TUH0D01	1.680	1.803	1.926	2.008	2.226	1.547	8,2	1,22 61
schiena bassa sx lh low backrest dossier bas gauche niedrige Rückenlehne li. respaldo bajo izdo	148	66	128	DI01TUH0S01	1.680	1.803	1.926	2.008	2.226	1.547	8,2	1,22 61
schiena alta dx rh high backrest dossier haut droite hohe Rückenlehne re. respaldo alto dh	148	78	128	DI01TUH0D02	1.699	1.822	1.945	2.027	2.246	1.568	8,2	1,45 69
schiena alta sx lh high backrest dossier haut gauche hohe Rückenlehne li. respaldo alto iz	148	78	128	DI01TUH0S02	1.699	1.822	1.945	2.027	2.246	1.568	8,2	1,45 69

modulo laterale 1 posto P. 100 cm
1-seat side element D. 100 cm
module latéral 1 place T. 100 cm
seitliches Modul 1 Sitz T. 100 cm
módulo lateral 1 plaza P. 100 cm

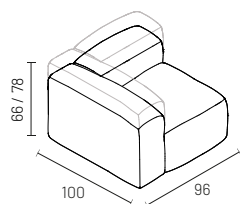

	L W	H H	P D	CODICE CODE	Basic	Start	Extra	Light	Super	t-cliente com-fabric	ml l.mt.	m³ kg
schiena e bracciolo bassi dx rh low backrest and armrest dossier et accoudoir bas droite niedrige Rücken-und Armlehne re. respaldo y brazo bajos, dchos	96	66	100	DI01TRBAD11	1.226	1.244	1.314	1.360	1.484	1.085	6	0,66 39
schiena e bracciolo bassi sx lh low backrest and armrest dossier et accoudoir bas gauche niedrige Rücken-und Armlehne le. respaldo y brazo bajos, izdos	96	66	100	DI01TRBAS11	1.226	1.244	1.314	1.360	1.484	1.085	6	0,66 39
schiena e bracciolo alti dx rh high backrest and armrest dossier et accoudoir hauts droite hohe Rücken-und Armlehne re. respaldo y brazo altos, dchos	96	78	100	DI01TRBAD22	1.263	1.281	1.351	1.398	1.522	1.125	6	0,73 44
schiena e bracciolo alti sx lh high backrest and armrest dossier et accoudoir hauts gauche hohe Rücken-und Armlehne le. respaldo y brazo altos, izdos	96	78	100	DI01TRBAS22	1.263	1.281	1.351	1.398	1.522	1.125	6	0,73 44
schiena alta e bracciolo basso dx rh high backrest with low armrest dossier haut et accoudoir bas droite hohe Rücken-und niedrige Armlehne re. respaldo alto y brazo bajo, dchos	96	78	100	DI01TRBAD12	1.245	1.263	1.333	1.379	1.503	1.105	6	0,69 41
schiena alta e bracciolo basso sx lh high backrest with low armrest dossier haut et accoudoir bas gauche hohe Rücken-und niedrige Armlehne li. respaldo alto y brazo bajo, izdos	96	78	100	DI01TRBAS12	1.245	1.263	1.333	1.379	1.503	1.105	6	0,69 41

modulo laterale 1 posto large P. 100 cm
1-seat large side element D. 100 cm
module latéral 1 place grand T. 100 cm
großes seitliches Modul 1 Sitz T. 100 cm
módulo lateral grande 1 plaza P. 100 cm

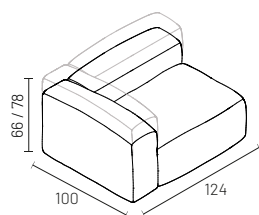

schiena e bracciolo bassi dx rh low backrest and armrest dossier et accoudoir bas droite niedrige Rücken-und Armlehne re. respaldo y brazo bajos, dchos	124	66	100	DI01TRBED11	1.375	1.401	1.479	1.530	1.668	1.226	6,5	0,69 44
schiena e bracciolo bassi sx lh low backrest and armrest dossier et accoudoir bas gauche niedrige Rücken-und Armlehne le. respaldo y brazo bajos, izdos	124	66	100	DI01TRBES11	1.375	1.401	1.479	1.530	1.668	1.226	6,5	0,69 44
schiena e bracciolo alti dx rh high backrest and armrest dossier et accoudoir hauts droite hohe Rücken-und Armlehne re. respaldo y brazo altos, dchos	124	78	100	DI01TRBED22	1.413	1.439	1.516	1.568	1.705	1.265	6,5	0,77 49
schiena e bracciolo alti sx lh high backrest and armrest dossier et accoudoir hauts gauche hohe Rücken-und Armlehne le. respaldo y brazo altos, izdos	124	78	100	DI01TRBES22	1.413	1.439	1.516	1.568	1.705	1.265	6,5	0,77 49
schiena alta e bracciolo basso dx rh high backrest with low armrest dossier haut et accoudoir bas droite hohe Rücken-und niedrige Armlehne re. respaldo alto y brazo bajo, dchos	124	78	100	DI01TRBED12	1.394	1.420	1.497	1.549	1.687	1.246	6,5	0,73 46
schiena alta e bracciolo basso sx lh high backrest with low armrest dossier haut et accoudoir bas gauche hohe Rücken-und niedrige Armlehne li. respaldo alto y brazo bajo, izdos	124	78	100	DI01TRBES12	1.394	1.420	1.497	1.549	1.687	1.246	6,5	0,73 46

modulo laterale 2 posti P. 100 cm
2-seat side element D. 100 cm
module latéral 2 places T. 100 cm
seitliches Modul 2 Sitze T. 100 cm
módulo lateral 2 plazas P. 100 cm

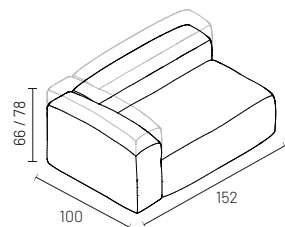

	L W	H H	P D	CODICE CODE	Basic	Start	Extra	Light	Super	t-cliente com-fabric	ml l.mt.	m ³ kg
schiena e bracciolo bassi dx rh low backrest and armrest dossier et accouoir bas droite niedrige Rücken-und Armlehne re. respaldo y brazo bajos, dchos	152	66	100	DI01TRBBD11	1.599	1.633	1.718	1.775	1.926	1.446	7	0,85 45
schiena e bracciolo bassi sx lh low backrest and armrest dossier et accouoir bas gauche niedrige Rücken-und Armlehne le. respaldo y brazo bajos, izdos	152	66	100	DI01TRBBS11	1.599	1.633	1.718	1.775	1.926	1.446	7	0,85 45
schiena e bracciolo alti dx rh high backrest and armrest dossier et accouoir hauts droite hohe Rücken-und Armlehne re. respaldo y brazo altos, dchos	152	78	100	DI01TRBBD22	1.636	1.670	1.755	1.812	1.964	1.485	7	0,96 50
schiena e bracciolo alti sx lh high backrest and armrest dossier et accouoir hauts gauche hohe Rücken-und Armlehne le. respaldo y brazo altos, izdos	152	78	100	DI01TRBBS22	1.636	1.670	1.755	1.812	1.964	1.485	7	0,96 50
schiena alta e bracciolo basso dx rh high backrest with low armrest dossier haut et accouoir bas droite hohe Rücken-und niedrige Armlehne re. respaldo alto y brazo bajo, dchos	152	78	100	DI01TRBBD12	1.618	1.651	1.737	1.793	1.945	1.466	7	0,9 47
schiena alta e bracciolo basso sx lh high backrest with low armrest dossier haut et accouoir bas gauche hohe Rücken-und niedrige Armlehne le. respaldo alto y brazo bajo, izdos	152	78	100	DI01TRBBS12	1.618	1.651	1.737	1.793	1.945	1.466	7	0,9 47

modulo laterale 1 posto large P. 128 cm
1-seat large side element D. 128 cm
module latéral 1 place grand T. 128 cm
großes seitliches Modul 1 Sitz T. 128 cm
módulo lateral grande 1 plaza P. 128 cm

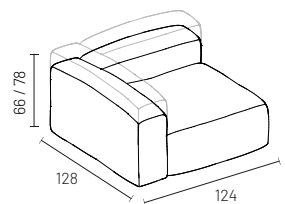

schiena e bracciolo bassi dx rh low backrest and armrest dossier et accouoir bas droite niedrige Rücken-und Armlehne re. respaldo y brazo bajos, dchos	124	66	128	DI01TRBFD11	1.620	1.636	1.721	1.778	1.930	1.449	7,5	0,85 45
schiena e bracciolo bassi sx lh low backrest and armrest dossier et accouoir bas gauche niedrige Rücken-und Armlehne le. respaldo y brazo bajos, izdos	124	66	128	DI01TRBFS11	1.620	1.636	1.721	1.778	1.930	1.449	7,5	0,85 45
schiena e bracciolo alti dx rh high backrest and armrest dossier et accouoir hauts droite hohe Rücken-und Armlehne re. respaldo y brazo altos, dchos	124	78	128	DI01TRBFD22	1.657	1.673	1.758	1.815	1.967	1.489	7,5	0,96 50
schiena e bracciolo alti sx lh high backrest and armrest dossier et accouoir hauts gauche hohe Rücken-und Armlehne le. respaldo y brazo altos, izdos	124	78	128	DI01TRBFS22	1.657	1.673	1.758	1.815	1.967	1.489	7,5	0,96 50
schiena alta e bracciolo basso dx rh high backrest with low armrest dossier haut et accouoir bas droite hohe Rücken-und niedrige Armlehne re. respaldo alto y brazo bajo, dchos	124	78	128	DI01TRBFD12	1.638	1.655	1.740	1.797	1.948	1.469	7,5	0,9 47
schiena alta e bracciolo basso sx lh high backrest with low armrest dossier haut et accouoir bas gauche hohe Rücken-und niedrige Armlehne le. respaldo alto y brazo bajo, izdos	124	78	128	DI01TRBFS12	1.638	1.655	1.740	1.797	1.948	1.469	7,5	0,9 47

modulo laterale 2 posti P. 128 cm
 2-seat side element D. 128 cm
 module latéral 2 places T. 128 cm
 seitliches Modul 2 Sitze T. 128 cm
 módulo lateral 2 plazas P. 128 cm

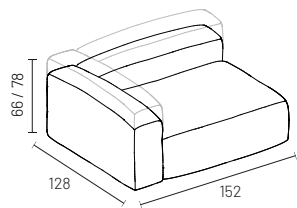

	L W	H H	P D	CODICE CODE	Basic	Start	Extra	Light	Super	t-cliente com-fabric	ml l.mt.	m³ kg
schiena e bracciolo bassi dx rh low backrest and armrest dossier et accoudoir bas droite niedrige Rücken-und Armlehne re. respaldo y brazo bajos, dchos	152	66	128	DI01TRBGD11	1.838	1.862	1.955	2.017	2.183	1.664	8	0,9 47
schiena e bracciolo bassi sx lh low backrest and armrest dossier et accoudoir bas gauche niedrige Rücken-und Armlehne le. respaldo y brazo bajos, izdos	152	66	128	DI01TRBGS11	1.838	1.862	1.955	2.017	2.183	1.664	8	0,9 47
schiena e bracciolo alti dx rh high backrest and armrest dossier et accoudoir hauts droite hohe Rücken-und Armlehne re. respaldo y brazo altos, dchos	152	78	128	DI01TRBGD22	1.875	1.900	1.993	2.055	2.220	1.703	8	1 52
schiena e bracciolo alti sx lh high backrest and armrest dossier et accoudoir hauts gauche hohe Rücken-und Armlehne le. respaldo y brazo altos, izdos	152	78	128	DI01TRBGS22	1.875	1.900	1.993	2.055	2.220	1.703	8	1 52
schiena alta e bracciolo basso dx rh high backrest with low armrest dossier haut et accoudoir bas droite hohe Rücken-und niedrige Armlehne re. respaldo alto y brazo bajo, dchos	152	78	128	DI01TRBGD12	1.855	1.879	1.972	2.034	2.199	1.681	8	0,96 50
schiena alta e bracciolo basso sx lh high backrest with low armrest dossier haut et accoudoir bas gauche hohe Rücken-und niedrige Armlehne li. respaldo alto y brazo bajo, izdos	152	78	128	DI01TRBGS12	1.855	1.879	1.972	2.034	2.199	1.681	8	0,96 50

modulo centrale 1 posto P. 100 cm
 1-seat central element D. 100 cm
 module central 1 place T. 100 cm
 Zentralmodul 1 Sitz T. 100 cm
 módulo central 1 plaza P. 100 cm

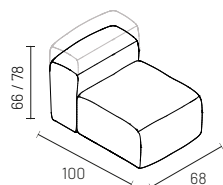

schiena bassa low backrest dossier bas niedrige Rückenlehne respaldo bajo	68	66	100	DI01TRCA01	894	914	968	1.004	1.101	787	4,5	0,48 32
schiena alta rh high backrest dossier haut droite hohe Rückenlehne re. respaldo alto dh	68	78	100	DI01TRCA02	913	932	987	1.023	1.119	806	4,5	0,53 36

modulo centrale 1 posto large P. 100 cm
 1-seat large central element D. 100 cm
 module central 1 place grand T. 100 cm
 großes Zentralmodul 1 Sitz T. 100 cm
 módulo central grande 1 plaza P. 100 cm

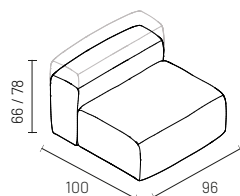

schiena bassa low backrest dossier bas niedrige Rückenlehne respaldo bajo	96	66	100	DI01TRCE01	1.027	1.054	1.116	1.158	1.268	910	5	0,62 39
schiena alta rh high backrest dossier haut droite hohe Rückenlehne re. respaldo alto dh	96	78	100	DI01TRCE02	1.045	1.073	1.135	1.176	1.287	930	5	0,74 41

TRAMA

moduli | units | modules | module | módulos

modulo centrale 1 posto large P. 128 cm
1-seat large central element D. 128 cm
module central 1 place grand T 128 cm
großes Zentralmodul 1 Sitz T. 128 cm
módulo central grande 1 plazo P. 128 cm

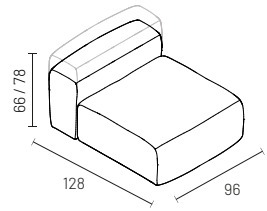

	L W	H H	P D	CODICE CODE	Basic	Start	Extra	Light	Super	t-cliente com-fabric	ml l.mt.	m³ kg
schiena bassa low backrest dossier bas niedrige Rückenlehne respaldo bajo	96	66	128	DI01TRCF01	1.190	1.225	1.295	1.342	1.466	1.065	5,5	0,8 42
schiena alta rh high backrest dossier haut droite hohe Rückenlehne re. respaldo alto dh	96	78	128	DI01TRCF02	1.209	1.244	1.314	1.360	1.484	1.085	5,5	0,96 50

modulo centrale 2 posti P. 100 cm
2-seat central element D. 100 cm
module central 2 places T. 100 cm
Zentralmodul 2 Sitze T. 100 cm
módulo central 2 plazos P. 100 cm

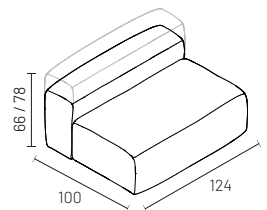

schiena bassa low backrest dossier bas niedrige Rückenlehne respaldo bajo	124	66	100	DI01TRCBD01	1.277	1.278	1.348	1.394	1.518	1.121	6,5	0,69 44
schiena alta rh high backrest dossier haut droite hohe Rückenlehne re. respaldo alto dh	124	78	100	DI01TRCBD02	1.296	1.297	1.366	1.413	1.537	1.141	6,5	0,77 49

modulo centrale 2 posti P. 128 cm
2-seat central element D. 128 cm
module central 2 places T. 128 cm
Zentralmodul 2 Sitze T. 128 cm
módulo central 2 plazos P. 128 cm

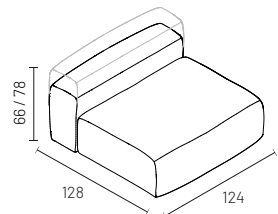

schiena bassa low backrest dossier bas niedrige Rückenlehne respaldo bajo	124	66	128	DI01TRCGD01	1.477	1.468	1.546	1.597	1.735	1.297	7,5	1 53
schiena alta rh high backrest dossier haut droite hohe Rückenlehne re. respaldo alto dh	124	78	128	DI01TRCGD02	1.496	1.487	1.564	1.616	1.754	1.317	7,5	1,2 60

TRAMA

moduli | units | modules | module | módulos

modulo centrale 1 posto senza schiena P. 72 cm
 1-seat central element without backrest D. 72 cm
 module central 1 place sans dossier T. 72 cm
 Zentralmodul 1 Sitz ohne Rückenlehne T. 72 cm
 módulo central 1 plazo sin respaldo P. 72 cm

L W	H H	P D	CODICE CODE	Basic	Start	Extra	Light	Super	t-cliente com-fabric	ml l.mt.	m ³ kg
--------	--------	--------	----------------	-------	-------	-------	-------	-------	-------------------------	-------------	----------------------

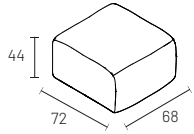

68	44	72	DI01TRCA000	503	534	565	586	641	462	2	0,22 20
----	----	----	-------------	-----	-----	-----	-----	-----	-----	---	------------

modulo centrale 1 posto large senza schiena P. 72 cm
 1-seat large central element without backrest D. 72 cm
 module central 1 place grand sans dossier T. 72 cm
 großes Zentralmodul 1 Sitz ohne Rückenlehne T. 72 cm
 módulo central grande 1 plazo sin respaldo P. 72 cm

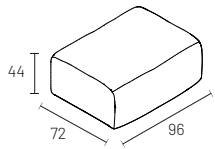

96	44	72	DI01TRCE000	620	659	698	724	793	569	2,5	0,29 24
----	----	----	-------------	-----	-----	-----	-----	-----	-----	-----	------------

modulo centrale 1 posto large senza schiena P. 100 cm
 1-seat large central element without backrest D. 100 cm
 module central 1 place grand sans dossier T. 100 cm
 großes Zentralmodul 1 Sitz ohne Rückenlehne T. 100 cm
 módulo central grande 1 plazo sin respaldo P. 100 cm

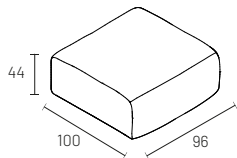

96	44	100	DI01TRCF000	775	822	868	899	982	715	3	0,42 24
----	----	-----	-------------	-----	-----	-----	-----	-----	-----	---	------------

TRAMA

moduli | units | modules | module | módulos

modulo centrale 2 posti senza schiena P. 72 cm
 2-seat central element without backrest D. 72 cm
 module central 2 places sans dossier T. 72 cm
 Zentralmodul 2 Sitze ohne Rückenlehne T. 72 cm
 módulo central 2 plazas sin respaldo P. 72 cm

L W	H H	P D	CODICE CODE	Basic	Start	Extra	Light	Super	t-cliente com-fabric	ml l.mt.	m ³ kg
--------	--------	--------	----------------	-------	-------	-------	-------	-------	-------------------------	-------------	----------------------

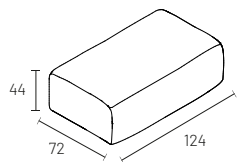

124	44	72	DI01TRCB000	772	818	865	896	979	712	3	0,38 30
-----	----	----	-------------	-----	-----	-----	-----	-----	-----	---	------------

modulo centrale 2 posti large senza schiena P. 100 cm
 2-seat central large element without backrest D. 100 cm
 module central 2 places grand sans dossier T. 100 cm
 großes Zentralmodul 2 Sitze ohne Rückenlehne T. 100 cm
 módulo central grande 2 plazas sin respaldo P. 100 cm

L W	H H	P D	CODICE CODE	Basic	Start	Extra	Light	Super	t-cliente com-fabric	ml l.mt.	m ³ kg
--------	--------	--------	----------------	-------	-------	-------	-------	-------	-------------------------	-------------	----------------------

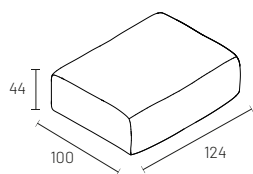

124	44	100	DI01TRCG000	941	978	1.032	1.068	1.165	855	4	0,54 28
-----	----	-----	-------------	-----	-----	-------	-------	-------	-----	---	------------

modulo centrale senza schiena L. 96 P. 148 cm
 central element without backrest W. 96 D. 148 cm
 module central sans dossier L. 96 T. 148 cm
 Zentralmodul ohne Rückenlehne B. 96 T. 148 cm
 módulo central sin respaldo A. 96 P. 148 cm

L W	H H	P D	CODICE CODE	Basic	Start	Extra	Light	Super	t-cliente com-fabric	ml l.mt.	m ³ kg
--------	--------	--------	----------------	-------	-------	-------	-------	-------	-------------------------	-------------	----------------------

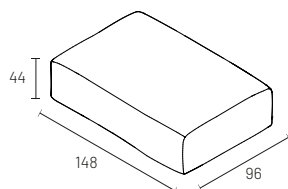

96	44	148	DI01TRCH000	1.075	1.145	1.215	1.261	1.385	979	4	0,61 33
----	----	-----	-------------	-------	-------	-------	-------	-------	-----	---	------------

TRAMA

moduli | units | modules | module | módulos

modulo centrale senza schiena L. 124 P. 140 cm
 central element without backrest W. 124 D. 140 cm
 module central sans dossier L. 124 T. 140 cm
 Zentralmodul ohne Rückenlehne B. 124 T. 140 cm
 módulo central sin respaldo A. 124 P. 140 cm

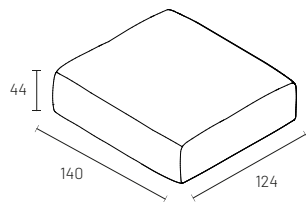

L W	H H	P D	CODICE CODE	Basic	Start	Extra	Light	Super	t-cliente com-fabric	ml l.mt.	m³ kg
--------	--------	--------	----------------	-------	-------	-------	-------	-------	-------------------------	-------------	----------

124	44	140	DI01TRCI000	1.123	1.242	1.327	1.384	1.536	1.030	4,5	0,75 50
-----	----	-----	-------------	-------	-------	-------	-------	-------	-------	-----	------------

modulo centrale senza schiena L. 124 P.148 cm
 central element without backrest W. 124 D. 148 cm
 module central sans dossier L. 124 T. 148 cm
 Zentralmodul ohne Rückenlehne B. 124 T. 148 cm
 módulo central sin respaldo A. 124 P. 148 cm

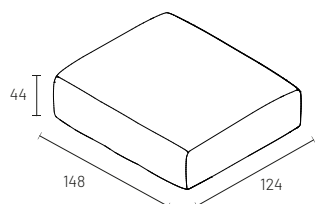

124	44	148	DI01TRCL000	1.201	1.346	1.439	1.501	1.666	1.113	4,5	0,8 42
-----	----	-----	-------------	-------	-------	-------	-------	-------	-------	-----	-----------

modulo pentagono centrale
 pentagonal central element
 module pentagonal central
 pentagonales Zentralmodul
 módulo pentagonal central

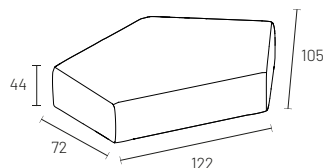

122	44	105	DI01TRN0000	1.427	1.464	1.519	1.555	1.651	1.373	4	0,6 38
-----	----	-----	-------------	-------	-------	-------	-------	-------	-------	---	-----------

modulo pentagono centrale con schiene
 pentagonal central element with backrests
 module pentagonal central avec dossiers
 pentagonales Zentralmodul mit Rückenlehne
 módulo pentagonal central con respaldo

L W	H H	P D	CODICE CODE	Basic	Start	Extra	Light	Super	t-cliente com-fabric	ml l.mt.	m ³ kg
--------	--------	--------	----------------	-------	-------	-------	-------	-------	-------------------------	-------------	----------------------

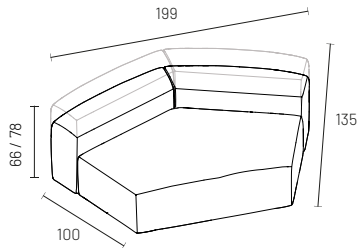

schiena bassa low backrest dossier bas niedrige Rückenlehne respaldo bajo	199	66	135	DI01TRN001	2.295	2.225	2.311	2.367	2.519	2.076	10	1,4 74
schiena alta rh high backrest dossier haut droite hohe Rückenlehne re. respaldo alto dh	199	78	135	DI01TRN002	2.333	2.288	2.381	2.443	2.609	2.117	10	1,6 85

modulo pentagono laterale con schiene
 pentagonal side element with backrests
 module pentagonal latéral avec dossiers
 pentagonales seitliches Modul mit Rückenlehne
 módulo pentagonal lateral con respaldo

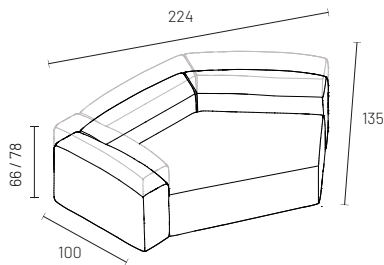

schiena e bracciolo bassi dx rh low backrest and armrest dossier et accoudoir bas droite niedrige Rücken-und Armlehne re. respaldo y brazo bajos, dchos	224	66	135	DI01TROOD11	2.704	2.581	2.682	2.749	2.928	2.402	13	1,54 81
schiena e bracciolo bassi sx lh low backrest and armrest dossier et accoudoir bas gauche niedrige Rücken-und Armlehne le. respaldo y brazo bajos, izdos	224	66	135	DI01TROOS11	2.704	2.581	2.682	2.749	2.928	2.402	13	1,54 81
schiena e bracciolo alti dx rh high backrest and armrest dossier et accoudoir hauts droite hohe Rücken-und Armlehne re. respaldo y brazo altos, dchos	224	78	135	DI01TROOD22	2.761	2.663	2.771	2.844	3.036	2.462	13	1,74 92
schiena e bracciolo alti sx lh high backrest and armrest dossier et accoudoir hauts gauche hohe Rücken-und Armlehne le. respaldo y brazo altos, izdos	224	78	135	DI01TROOS22	2.761	2.663	2.771	2.844	3.036	2.462	13	1,74 92
schiena alta e bracciolo basso dx rh high backrest with low armrest dossier haut et accoudoir bas droite hohe Rücken-und niedrige Armlehne re. respaldo alto y brazo bajo, dchos	224	78	135	DI01TROOD12	2.741	2.628	2.732	2.801	2.986	2.441	13	1,64 86
schiena alta e bracciolo basso sx lh high backrest with low armrest dossier haut et accoudoir bas gauche hohe Rücken-und niedrige Armlehne li. respaldo alto y brazo bajo, izdos	224	78	135	DI01TROOS12	2.741	2.628	2.732	2.801	2.986	2.441	13	1,64 86

modulo pentagono terminale con 1 schiena
 pentagonal end element with 1 backrest
 module pentagonal terminal avec 1 dossier
 pentagonales Abschlussmodul mit 1 Rückenlehne
 módulo pentagonal terminal con 1 respaldo

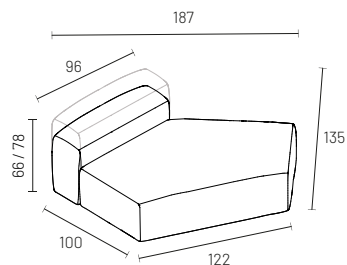

raffigurato dx
 rh in the figure
 illustré à droite
 rechts dargestellt
 representado dcho

	L W	H H	P D	CODICE CODE	Basic	Start	Extra	Light	Super	t-cliente com-fabric	ml l.mt.	m³ kg
schiena bassa dx rh low backrest dossier bas droite niedrige Rückenlehne re. respaldo bajo dcho	187	66	135	DI01TRP0D01	1.790	1.749	1.811	1.852	1.962	1.649	7	1,3 66
schiena bassa sx lh low backrest dossier bas gauche niedrige Rückenlehne li. respaldo bajo izdo	187	66	135	DI01TRP0S01	1.790	1.749	1.811	1.852	1.962	1.649	7	1,3 66
schiena alta dx rh high backrest dossier haut droite hohe Rückenlehne re. respaldo alto dh	187	78	135	DI01TRP0D02	1.809	1.793	1.863	1.909	2.033	1.670	7	1,5 78
schiena alta sx lh high backrest dossier haut gauche hohe Rückenlehne li. respaldo alto iz	187	78	135	DI01TRP0D02	1.809	1.793	1.863	1.909	2.033	1.670	7	1,5 78

angolo
 corner unit
 angle
 Ecke
 ángulo

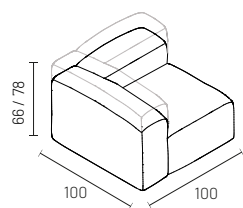

schiena e bracciolo bassi dx rh low backrest and armrest dossier et accoudoir bas droite niedrige Rücken-und Armlehne re. respaldo y brazo bajos, dchos	100	66	100	DI01TRF0D11	1.241	1.267	1.344	1.396	1.534	1.083	6,5	0,66 39
schiena e bracciolo bassi sx lh low backrest and armrest dossier et accoudoir bas gauche niedrige Rücken-und Armlehne le. respaldo y brazo bajos, izdos	100	66	100	DI01TRF0S11	1.241	1.267	1.344	1.396	1.534	1.083	6,5	0,66 39
schiena e bracciolo alti dx rh high backrest and armrest dossier et accoudoir hauts droite hohe Rücken-und Armlehne re. respaldo y brazo altos, dchos	100	78	100	DI01TRF0D22	1.278	1.329	1.414	1.471	1.623	1.122	6,5	0,73 44
schiena e bracciolo alti sx lh high backrest and armrest dossier et accoudoir hauts gauche hohe Rücken-und Armlehne le. respaldo y brazo altos, izdos	100	78	100	DI01TRF0S22	1.278	1.329	1.414	1.471	1.623	1.122	6,5	0,73 44

angolo large
large corner element
grand angle
große Eckelement
elemento ángulo grande

L W	H H	P D	CODICE CODE	Basic	Start	Extra	Light	Super	t-cliente com-fabric	ml l.mt.	m ³ kg
--------	--------	--------	----------------	-------	-------	-------	-------	-------	-------------------------	-------------	----------------------

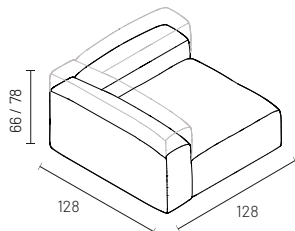

schiena e bracciolo bassi dx rh low backrest and armrest dossier et accoudoir bas droite niedrige Rücken-und Armlehne re. respaldo y brazo bajos, dchos	128	66	128	DI01TRF1D11	1.623	1.664	1.757	1.819	1.985	1.453	7,5	1,02 53
schiena e bracciolo bassi sx lh low backrest and armrest dossier et accoudoir bas gauche niedrige Rücken-und Armlehne le. respaldo y brazo bajos, izdos	128	66	128	DI01TRF1S11	1.623	1.664	1.757	1.819	1.985	1.453	7,5	1,02 53
schiena e bracciolo alti dx rh high backrest and armrest dossier et accoudoir hauts droite hohe Rücken-und Armlehne re. respaldo y brazo altos, dchos	128	78	128	DI01TRF1D22	1.660	1.727	1.827	1.894	2.074	1.492	7,5	1,23 58
schiena e bracciolo alti sx lh high backrest and armrest dossier et accoudoir hauts gauche hohe Rücken-und Armlehne le. respaldo y brazo altos, izdos	128	78	128	DI01TRF1S22	1.660	1.727	1.827	1.894	2.074	1.492	7,5	1,23 58

chaise longue P. 176 cm
chaise longue D. 176 cm
chaise longue T. 176 cm
chaise longue T. 176 cm
chaise longue P. 176 cm

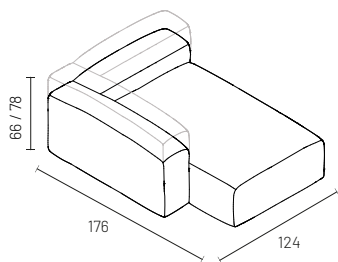

schiena e bracciolo bassi dx rh low backrest and armrest dossier et accoudoir bas droite niedrige Rücken-und Armlehne re. respaldo y brazo bajos, dchos	124	66	176	DI01TRI0D11	1.995	2.000	2.108	2.181	2.374	1.757	10	1,45 76
schiena e bracciolo bassi sx lh low backrest and armrest dossier et accoudoir bas gauche niedrige Rücken-und Armlehne le. respaldo y brazo bajos, izdos	124	66	176	DI01TRIOS11	1.995	2.000	2.108	2.181	2.374	1.757	10	1,45 76
schiena e bracciolo alti dx rh high backrest and armrest dossier et accoudoir hauts droite hohe Rücken-und Armlehne re. respaldo y brazo altos, dchos	124	78	176	DI01TRI0D22	2.032	2.062	2.178	2.256	2.462	1.796	10	1,72 88
schiena e bracciolo alti sx lh high backrest and armrest dossier et accoudoir hauts gauche hohe Rücken-und Armlehne le. respaldo y brazo altos, izdos	124	78	176	DI01TRIOS22	2.032	2.062	2.178	2.256	2.462	1.796	10	1,72 88
schiena alta e bracciolo basso dx rh high backrest with low armrest dossier haut et accoudoir bas droite hohe Rücken-und niedrige Armlehne re. respaldo alto y brazo bajo, dchos	124	78	176	DI01TRI0D12	2.013	2.028	2.140	2.214	2.413	1.777	10	1,58 82
schiena alta e bracciolo basso sx lh high backrest with low armrest dossier haut et accoudoir bas gauche hohe Rücken-und niedrige Armlehne li. respaldo alto y brazo bajo, izdos	124	78	176	DI01TRIOS12	2.013	2.028	2.140	2.214	2.413	1.777	10	1,58 82

chaise longue large P. 168 cm
 large chaise longue D. 168 cm
 chaise longue grande T. 168 cm
 große chaise longue T. 168 cm
 chaise longue grande P. 168 cm

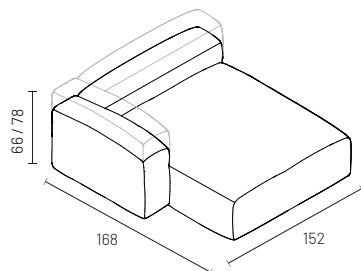

	L W	H H	P D	CODICE CODE	Basic	Start	Extra	Light	Super	t-cliente com-fabric	ml l.mt.	m ³ kg
schiena e bracciolo bassi dx rh low backrest and armrest dossier et accoudoir bas droite niedrige Rücken-und Armlehne re. respaldo y brazo bajos, dchos	152	66	168	DI01TRI1D11	1.995	2.000	2.108	2.181	2.374	1.757	10	1,7 90
schiena e bracciolo bassi sx lh low backrest and armrest dossier et accoudoir bas gauche niedrige Rücken-und Armlehne le. respaldo y brazo bajos, izdos	152	66	168	DI01TRI1S11	1.995	2.000	2.108	2.181	2.374	1.757	10	1,7 90
schiena e bracciolo alti dx rh high backrest and armrest dossier et accoudoir hauts droite hohe Rücken-und Armlehne re. respaldo y brazo altos, dchos	152	78	168	DI01TRI1D22	2.032	2.062	2.178	2.256	2.462	1.796	10	2 98
schiena e bracciolo alti sx lh high backrest and armrest dossier et accoudoir hauts gauche hohe Rücken-und Armlehne le. respaldo y brazo altos, izdos	152	78	168	DI01TRI1S22	2.032	2.062	2.178	2.256	2.462	1.796	10	2 98
schiena alta e bracciolo basso dx rh high backrest with low armrest dossier haut et accoudoir bas droite hohe Rücken-und niedrige Armlehne re. respaldo alto y brazo bajo, dchos	152	78	168	DI01TRI1D12	2.013	2.028	2.140	2.214	2.413	1.777	10	1,85 94
schiena alta e bracciolo basso sx lh high backrest with low armrest dossier haut et accoudoir bas gauche hohe Rücken-und niedrige Armlehne ll. respaldo alto y brazo bajo, izdos	152	78	168	DI01TRI1S12	2.013	2.028	2.140	2.214	2.413	1.777	10	1,85 94

chaise longue large P. 176 cm
 large chaise longue D. 176 cm
 chaise longue grande T. 176 cm
 große chaise longue T. 176 cm
 chaise longue grande P. 176 cm

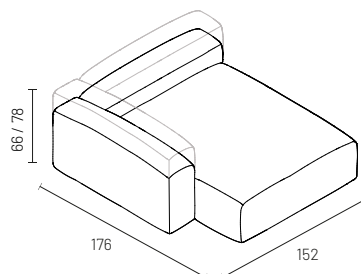

schiena e bracciolo bassi dx rh low backrest and armrest dossier et accoudoir bas droite niedrige Rücken-und Armlehne re. respaldo y brazo bajos, dchos	152	66	176	DI01TRI2D11	2.200	2.213	2.330	2.407	2.614	1.957	10,5	1,78 92
schiena e bracciolo bassi sx lh low backrest and armrest dossier et accoudoir bas gauche niedrige Rücken-und Armlehne le. respaldo y brazo bajos, izdos	152	66	176	DI01TRI2S11	2.200	2.213	2.330	2.407	2.614	1.957	10,5	1,78 92
schiena e bracciolo alti dx rh high backrest and armrest dossier et accoudoir hauts droite hohe Rücken-und Armlehne re. respaldo y brazo altos, dchos	152	78	176	DI01TRI2D22	2.238	2.276	2.400	2.482	2.703	1.997	10,5	2,11 101
schiena e bracciolo alti sx lh high backrest and armrest dossier et accoudoir hauts gauche hohe Rücken-und Armlehne le. respaldo y brazo altos, izdos	152	78	176	DI01TRI2S22	2.238	2.276	2.400	2.482	2.703	1.997	10,5	2,11 101
schiena alta e bracciolo basso dx rh high backrest with low armrest dossier haut et accoudoir bas droite hohe Rücken-und niedrige Armlehne re. respaldo alto y brazo bajo, dchos	152	78	176	DI01TRI2D12	2.219	2.242	2.361	2.441	2.653	1.977	10,5	1,94 96
schiena alta e bracciolo basso sx lh high backrest with low armrest dossier haut et accoudoir bas gauche hohe Rücken-und niedrige Armlehne ll. respaldo alto y brazo bajo, izdos	152	78	176	DI01TRI2S12	2.219	2.242	2.361	2.441	2.653	1.977	10,5	1,94 96

terminale
end unit
el. terminal
Abschlusselement
elemento terminal

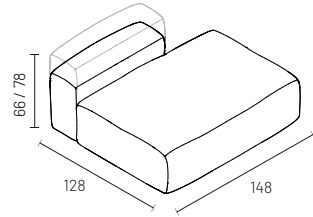

raffigurato dx
rh in the figure
illustré à droite
rechts dargestellt
representado dcho

L W	H H	P D	CODICE CODE	Basic	Start	Extra	Light	Super	t-cliente com-fabric	ml l.mt.	m ³ kg
--------	--------	--------	----------------	-------	-------	-------	-------	-------	-------------------------	-------------	----------------------

schiena bassa dx rh low backrest dossier bas droite niedrige Rückenlehne re. respaldo bajo dcho	148	66	128	DI01TRH0D01	1.447	1.557	1.650	1.712	1.878	1.339	5,5	1,22 61
schiena bassa sx lh low backrest dossier bas gauche niedrige Rückenlehne li. respaldo bajo izdo	148	66	128	DI01TRH0S01	1.447	1.557	1.650	1.712	1.878	1.339	5,5	1,22 61
schiena alta dx rh high backrest dossier haut droite hohe Rückenlehne re. respaldo alto dh	148	78	128	DI01TRH0D02	1.466	1.601	1.702	1.769	1.948	1.359	5,5	1,45 69
schiena alta sx lh high backrest dossier haut gauche hohe Rückenlehne li. respaldo alto iz	148	78	128	DI01TRH0S02	1.466	1.601	1.702	1.769	1.948	1.359	5,5	1,45 69

composizione 1 (rappresentata sx)
 composition 1 (lh in the picture)
 composition 1 (illustré à gauche)
 Zusammenstellung 1 (links dargestellt)
 Composición 1 (representada a la izquierda)

L W	H H	P D	CODICE CODE	Basic	Start	Extra	Light	Super	t-cliente com-fabric	ml l.mt.	m ² kg
--------	--------	--------	----------------	-------	-------	-------	-------	-------	-------------------------	-------------	----------------------

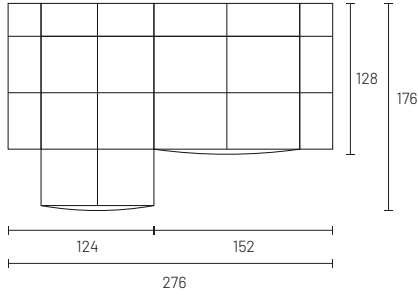

276	78	176	TRAMC1	4.305	4.591	5.366	5.576	6.136	4.035	18,6	2,35 123
-----	----	-----	--------	-------	-------	-------	-------	-------	-------	------	-------------

composizione 2 (rappresentata sx)
 composition 2 (lh in the picture)
 composition 2 (illustré à gauche)
 Zusammenstellung 2 (links dargestellt)
 Composición 2 (representada a la izquierda)

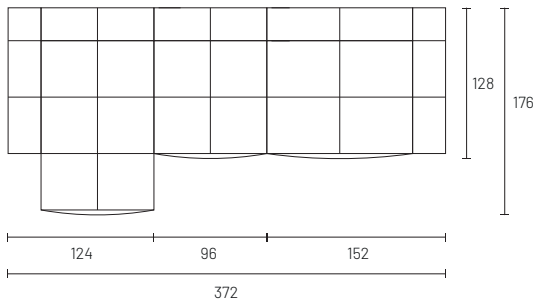

372	78	176	TRAMC2	5.590	5.963	6.971	7.245	7.975	5.236	24,4	3,15 165
-----	----	-----	--------	-------	-------	-------	-------	-------	-------	------	-------------

composizione 3 (rappresentata dx)
 composition 3 (rh in the picture)
 composition 3 (illustré à droite)
 Zusammenstellung 3 (rechts dargestellt)
 Composición 3 (representada a la derecha)

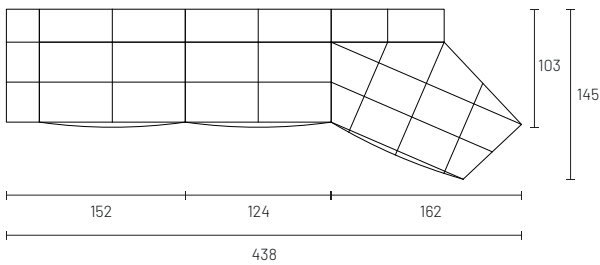

438	78	145	TRAMC3	5.234	5.562	6.479	6.720	7.363	4.954	21,9	2,84 155
-----	----	-----	--------	-------	-------	-------	-------	-------	-------	------	-------------

composizione 4 (rappresentata dx)
 composition 4 (rh in the picture)
 composition 4 (illustré à droite)
 Zusammenstellung 4 (rechts dargestellt)
 Composición 4 (representada a la derecha)

L W	H H	P D	CODICE CODE	Basic	Start	Extra	Light	Super	t-cliente com-fabric	ml l.mt.	m³ kg
--------	--------	--------	----------------	-------	-------	-------	-------	-------	-------------------------	-------------	----------

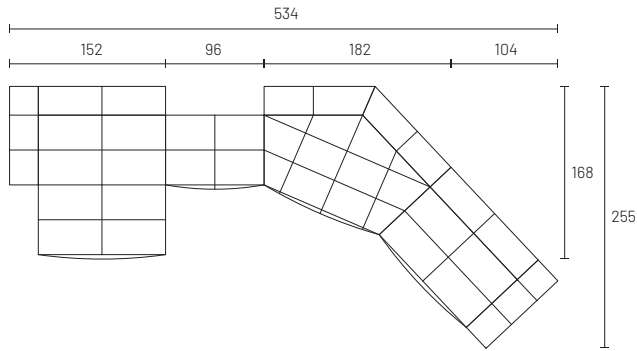

534	78	255	TRAMC4	7.315	7.804	9.123	9.481	10.437	6.851	33,1	4,24 233
-----	----	-----	--------	-------	-------	-------	-------	--------	-------	------	-------------

composizione 5 (rappresentata dx)
 composition 5 (rh in the picture)
 composition 5 (illustré à droite)
 Zusammenstellung 5 (rechts dargestellt)
 Composición 5 (representada a la derecha)

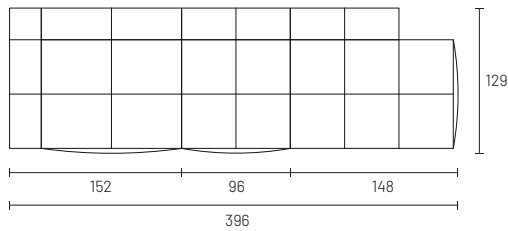

396	78	129	TRAMC5	5.060	5.393	6.106	6.342	6.971	4.752	22,2	2,92 150
-----	----	-----	--------	-------	-------	-------	-------	-------	-------	------	-------------

composizione 6 (rappresentata dx)
 composition 6 (rh in the picture)
 composition 6 (illustré à droite)
 Zusammenstellung 6 (rechts dargestellt)
 Composición 6 (representada a la derecha)

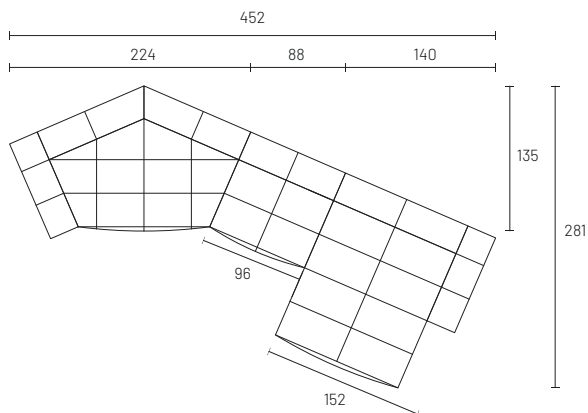

452	78	281	TRAMC6	6.303	6.731	7.875	8.188	9.023	5.888	29,3	3,86 210
-----	----	-----	--------	-------	-------	-------	-------	-------	-------	------	-------------



BASAMENTO, GAMBE E PIANO: pannello di particelle di legno certificato CARB-02 sp. 25 mm finitura laccata opaca o lucida.

BASE, FEET AND TOP: 25 mm thick CARB-02 certified wood particle board panels in matt or glossy lacquer finish

PIETEMENT, PIEDS ET PLATEAU: panneau de particules de bois certifié CARB-02 ép. 25 mm finition laquée mate ou brillante.

UNTERTEIL, FÜSSE UND PLATTE: CARB-02-zertifizierte Spanplatte, Stärke 25 mm, matt oder glänzend lackiert.

BASE, PATAS Y SOBRE: aglomerado de madera certificado CARB-02 de 25 mm de grosor, en laca mate o brillo.

TRAMA A

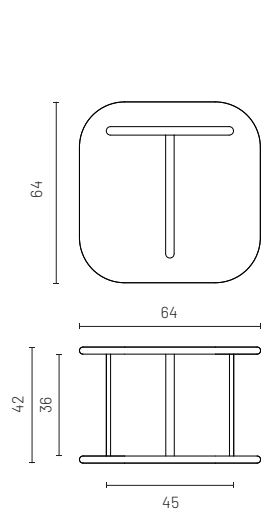

TRAMA B

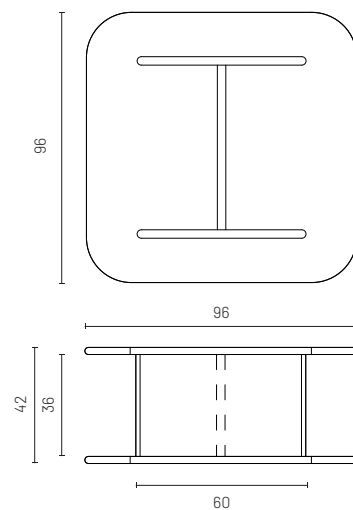

TRAMA C

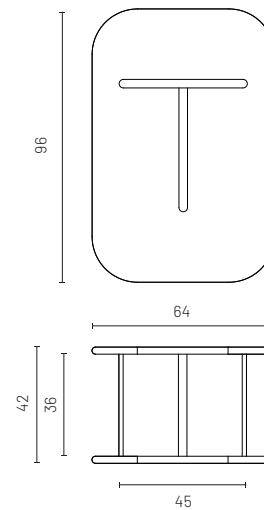

TRAMA D

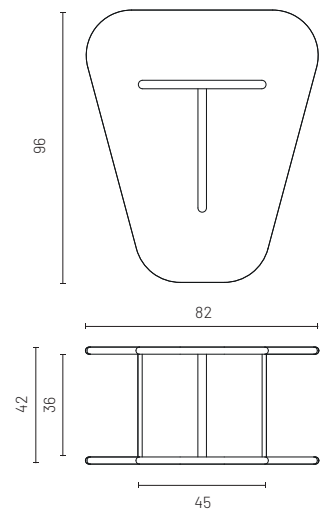

tavolino Trama A
Trama A side table
table basse Trama A
Couchtisch Trama A
mesita Trama A

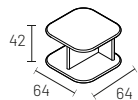

L W	H H	P D	CODICE CODE	Lacc. opaco Matt lacq.	Lacc. lucido Glossy lacq.	m ³ kg
--------	--------	--------	----------------	---------------------------	------------------------------	----------------------

64	42	64	DI01TRTV00A	412	495	0,18 26
----	----	----	-------------	-----	-----	------------

tavolino Trama B
Trama B side table
table basse Trama B
Couchtisch Trama B
mesita Trama B

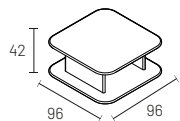

96	42	96	DI01TRTV00B	744	893	0,41 45
----	----	----	-------------	-----	-----	------------

tavolino Trama C
Trama C side table
table basse Trama C
Couchtisch Trama C
mesita Trama C

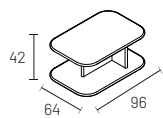

96	42	64	DI01TRTV00C	521	625	0,18 30
----	----	----	-------------	-----	-----	------------

tavolino Trama D
Trama D side table
table basse Trama D
Couchtisch Trama D
mesita Trama D

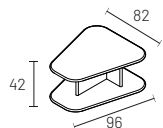

82	42	96	DI01TRTV00D	567	680	0,2 31
----	----	----	-------------	-----	-----	-----------

CUSCINI | CUSHIONS | COUSSINS | KISSEN | COJINES

cuscinò 45 x 45 cm
cushion 45 x 45 cm
coussin 45 x 45 cm
Kissen 45 x 45 cm
cojìn 45 x 45 cm

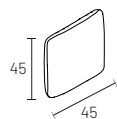

L W	H H	P D	CODICE CODE
--------	--------	--------	----------------

Basic	Start	Extra	Light	Super	K	W	t-cliente com-fabric	ml l.mt.	m³ kg
-------	-------	-------	-------	-------	---	---	-------------------------	-------------	----------

45	45	20	DI01TRX4545
----	----	----	-------------

149	165	182	193	222	324	412	112	0,8	0,03 0,3
-----	-----	-----	-----	-----	-----	-----	-----	-----	-------------

cuscinò 55 x 55 cm
cushion 55 x 55 cm
coussin 55 x 55 cm
Kissen 55 x 55 cm
cojìn 55 x 55 cm

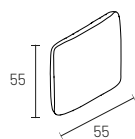

55	55	20	DI01TRX5555
----	----	----	-------------

151	167	184	195	224	327	415	114	1	0,03 0,3
-----	-----	-----	-----	-----	-----	-----	-----	---	-------------

cuscinò 53 x 41 cm
cushion 53 x 41 cm
coussin 53 x 41 cm
Kissen 53 x 41 cm
cojìn 53 x 41 cm

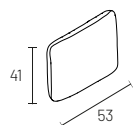

53	41	20	DI01TRX5341
----	----	----	-------------

139	152	166	174	198	290	364	110	0,8	0,03 0,3
-----	-----	-----	-----	-----	-----	-----	-----	-----	-------------

cuscinò 65 x 30 cm
cushion 65 x 30 cm
coussin 65 x 30 cm
Kissen 65 x 30 cm
cojìn 65 x 30 cm

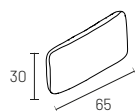

65	30	20	DI01TRX6530
----	----	----	-------------

157	177	197	210	245	370	476	113	1,2	0,03 0,3
-----	-----	-----	-----	-----	-----	-----	-----	-----	-------------

Composizione interna misto fiocco. | Maggiorazione per cuscinò con bordino cannettato o stesso tessuto: 15€. | Internal composition: mixed fiberfill. | Surcharge for cushion with ribbed piping or in the same fabric as the upholstery: 15€. | Composition interne mixte flocon. | Supplément pour coussin avec passepoil côtelé ou avec le même tissu que le revêtement: 15€. | Innere Zusammensetzung gemischtes Schleife. | Aufpreis für Kissen mit Stoffborde Typ canneté oder mit dem gleichen Stoff des Bezuges: 15€. | Composición interna mixto copo. | Recargo por cojìn con franja en canneté o con el mismo tejido del revestimiento: 15€.

CUSCINI | CUSHIONS | COUSSINS | KISSEN | COJINES

cuscinò con fascia 37 x 37 cm
cushion with band 37 x 37 cm
coussin avec bande 37 x 37 cm
Kissen mit Band 37 x 37 cm
cojìn con banda 37 x 37 cm

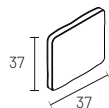

L W	H H	P D	CODICE CODE	Basic	Start	Extra	Light	Super	K	W	t-cliente com-fabric	ml l.mt.	m ³ kg
--------	--------	--------	----------------	-------	-------	-------	-------	-------	---	---	-------------------------	-------------	----------------------

37	37	20	DI01TRX3737	149	165	182	193	222	324	412	112	0,8	0,03 0,3
----	----	----	-------------	-----	-----	-----	-----	-----	-----	-----	-----	-----	-------------

cuscinò con fascia 47 x 47 cm
cushion with band 47 x 47 cm
coussin avec bande 47 x 47 cm
Kissen mit Band 47 x 47 cm
cojìn con banda 47 x 47 cm

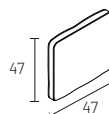

47	47	20	DI01TRX4747	149	165	182	193	222	324	412	112	0,8	0,03 0,3
----	----	----	-------------	-----	-----	-----	-----	-----	-----	-----	-----	-----	-------------

cuscinò con fascia 45 x 33 cm
cushion with band 45 x 33 cm
coussin avec bande 45 x 33 cm
Kissen mit Band 45 x 33 cm
cojìn con banda 45 x 33 cm

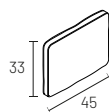

45	33	20	DI01TRX4533	149	165	182	193	222	324	412	112	0,8	0,03 0,3
----	----	----	-------------	-----	-----	-----	-----	-----	-----	-----	-----	-----	-------------

cuscinò con fascia 57 x 22 cm
cushion with band 57 x 22 cm
coussin avec bande 57 x 22 cm
Kissen mit Band 57 x 22 cm
cojìn con banda 57 x 22 cm

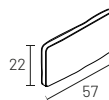

57	22	20	DI01TRX5722	139	152	166	174	198	290	364	110	0,8	0,03 0,3
----	----	----	-------------	-----	-----	-----	-----	-----	-----	-----	-----	-----	-------------

POLTRONE | ARMCHAIRS | FAUTEUILS | SESSEL | SILLONES

FLO 102



MILTON 112



GULP LOUNGE 104



PANAMA 114



HULL LOUNGE 106



PLANKA 116



LE MANS LOUNGE 108



SUPERNOVA 118



MADAME 110





STRUTTURA E SCHIENALE: costruiti in schiumato.

SEDUTA: imbottita in poliuretano espanso.

BASAMENTO: in metallo verniciato nero. Disponibile in champagne, titanio o laccato opaco con maggiorazione: 25€ cadauno.

RIVESTIMENTO: Non disponibile in Fintapelle vintage/intreccio (Extra) e in Cartagena (Start). Sfoderabile in tessuto. Non sfoderabile.

TESSUTO CLIENTE: il tessuto cliente non comprende le pelli. Per la metratura vedi listino.

STRUCTURE AND BACK: made of molded foam.

SEAT: padded with expanded polyurethane foam

BASE: in black varnished metal. Also available in champagne, titanium, or matte lacquered with an additional charge of €25 each feet.

UPHOLSTERY: Not available in Fintapelle Vintage/Intreccio (Extra) and Cartagena (Start). Removable cover in the fabric version. Non removable.

CUSTOMER FABRIC: Customer fabric does not include leather. For the required linear metres, see the price list.

STRUCTURE ET DOSSIER: construits en mousse.

ASSISE: rembourré en polyuréthane expansé.

SUPPORT: en métal laqué en noir. Disponible en champagne, titane ou laqué mat avec supplément : 25 € chacun.

REVÊTEMENT: Non disponible dans Fintapelle vintage/Intreccio (catégorie Extra) et dans Cartagena (catégorie Start). Tissu déhoussable. Non déhoussable.

TISSU CLIENT: le tissu client n'inclut pas les cuirs. Pour le métrage, voir le tarif.

AUFBAU UND RÜCKENLEHNE: Aus Schaumstoff gebaut.

SITZFLÄCHE: mit Polyurethanschaum gepolstert.

UNTERTEIL: aus schwarz lackiertem Metall. Auch in Ausführung Champagne, Titanio oder Mattlack gegen Aufpreis von 25 € pro Fuß.

ABDECKUNG: Nicht verfügbar im Fintapelle Vintage/Intreccio (Extra) und im Cartagena (Start). Vollständig abziehbar in der Stoffversion. Nicht abziehbar.

EIGENSTOFF: Vom Kunden bereitgestellter Stoff umfasst kein Leder. Für den benötigten Stoffverbrauch siehe Preisliste.

ESTRUCTURA Y RESPALDO: fabricados en espuma.

ASIENTO: acolchado con poliuretano expandido.

BASE: en metal lacado negro. Disponible en champagne, titanio o lacado mate con recargo de 25 € cada uno.

REVESTIMIENTO: No disponible en Fintapelle Vintage/Intreccio (Extra) ni en Cartagena (Start). Desenfundable en la versión tejido. No desenfundable.

TELA CLIENTE: El tejido proporcionado por el cliente no incluye pieles. Para el metraje, consulte la lista de precios.

FLO

poltrona
armchair
fauteuil
Sessel
sillón

L W	H H	P D	CODICE CODE	Basic	Start	Extra	Light	Super	K	W	t-cliente com-fabric	ml l.mt.	m ³ kg
--------	--------	--------	----------------	-------	-------	-------	-------	-------	---	---	-------------------------	-------------	----------------------

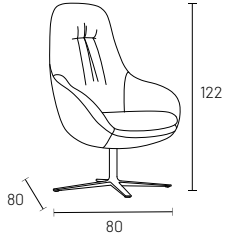

80	122	80	DI02FI001	1.256	1.326	1.396	1.443	1.567	2.034	2.406	1.136	4	0,7 32
----	-----	----	-----------	-------	-------	-------	-------	-------	-------	-------	-------	---	-----------

Basamento standard verniciato nero, disponibile in champagne, titanio o laccato opaco con maggiorazione: 25 €. | Standard base painted black, also available in champagne, titanium, or matte lacquered with an additional charge of € 25. | Support standard laqué en noir, disponibles en champagne, titane ou laqué mat avec supplément : 25 €. | Standard Unterteil in schwarz lackiert, auch in Ausführung Champagne, Titanio oder Mattlack gegen Aufpreis von 25 €. | Base estándar pintados en negro, disponibles en champagne, titanio o lacado mate con un recargo de 25 €.

GULP LOUNGE



STRUTTURA E SCHIENALE: in multistrato curvato rivestito in poliuretano espanso.
SEDUTA: imbottita in poliuretano espanso ad alta densità e ricoperto con lenta memoria.
BASAMENTO: in legno nelle finiture essenza.
RIVESTIMENTO: sfoderabile solo il cuscino di seduta.
TESSUTO CLIENTE: il tessuto cliente non comprende le pelli. Per la metratura vedi listino.

STRUCTURE AND BACK: in curved-shaped plywood covered with polyurethane foam.
SEAT: padded with high density expanded polyurethane foam and covered with slow-memory foam layer.
BASE: in the wood finishes.
UPHOLSTERY: only the seat cushion has a removable cover.
CUSTOMER FABRIC: Customer fabric does not include leather. For the required linear metres, see the price list.

STRUCTURE ET DOSSIER: en multiplis courbé revêtu de polyuréthane expansé.
ASSISE: rembourrés en polyuréthane expansé à haute densité et recouverts de mousse à mémoire lente.
SUPPORT: en bois.
REVÊTEMENT: seul le coussin d'assise est déhoussable.
TISSU CLIENT: le tissu client n'inclut pas les cuirs. Pour le métrage, voir le tarif.

AUFBAU UND RÜCKENLEHNE: aus gebogenem Sperrholz, beschichtet mit Polyurethanschaum beschichtet.
SITZFLÄCHE: gepolstert aus Polyurethanschaum, mit strapazierfähigem Material bezogen.
UNTERTEIL: aus Holz, in den verfügbaren Ausführungen
ABDECKUNG: Nur das Sitzkissen ist abziehbar.
EIGENSTOFF: Vom Kunden bereitgestellter Stoff umfasst kein Leder. Für den benötigten Stoffverbrauch siehe Preisliste.

ESTRUCTURA Y RESPALDO: en multicapa curvada revestida con poliuretano expandido.
ASIENTO: acolchado con poliuretano expandido de alta densidad y revestido con espuma viscoelástica.
BASE: en madera, en los acabados ofrecidos.
REVESTIMIENTO: solo el cojín del asiento es desenfundable.
TELA CLIENTE: El tejido proporcionado por el cliente no incluye pieles. Para el metraje, consulte la lista de precios.

GULP LOUNGE

poltrona
armchair
fauteuil
Sessel
sillón

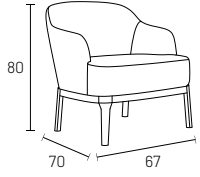

L W	H H	P D	CODICE CODE	Basic	Start	Extra	Light	Super	K	W	t-cliente com-fabric	ml l.mt.	m ³ kg
--------	--------	--------	----------------	-------	-------	-------	-------	-------	---	---	-------------------------	-------------	----------------------

67	80	70	DI02GU001	1.310	1.351	1.383	1.408	1.473	1.749	1.972	1.227	2,2	0,6 20
----	----	----	-----------	-------	-------	-------	-------	-------	-------	-------	-------	-----	-----------

HULL LOUNGE

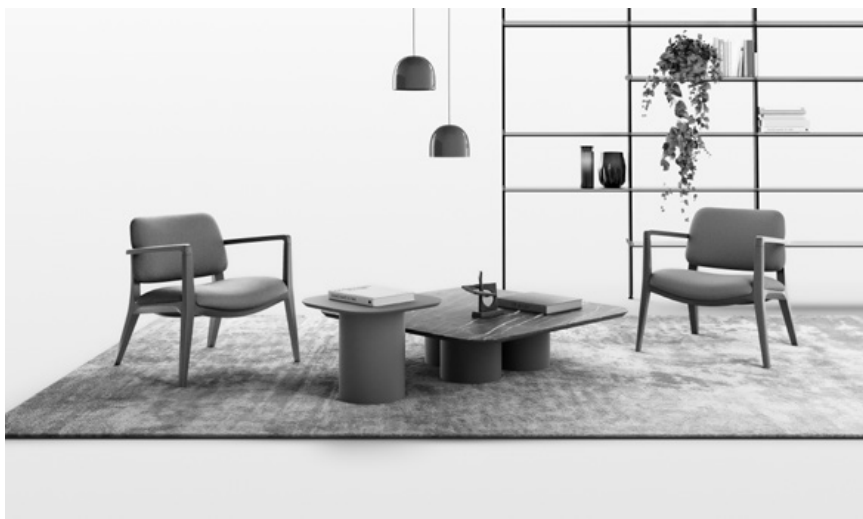

STRUTTURA: in legno nelle finiture essenza.

SEDUTA E SCHIENALE: in poliuretano espanso.

RIVESTIMENTO: non sfoderabile.

TESSUTO CLIENTE: il tessuto cliente non comprende le pelli. Per la metratura vedi listino.

STRUCTURE: in the wood finishes.

SEAT AND BACKREST: in expanded polyurethane foam.

UPHOLSTERY: non removable.

CUSTOMER FABRIC: Customer fabric does not include leather. For the required linear metres, see the price list.

STRUCTURE: en bois.

ASSISE ET DOSSIER: en polyuréthane expansé.

REVÊTEMENT: non déhoussable.

TISSU CLIENT: le tissu client n'inclut pas les cuirs. Pour le métrage, voir le tarif.

STRUKTUR: aus Holz, in den verfügbaren Ausführungen

SITZFLÄCHE UND RÜCKENLEHNE: aus Polyurethanschäum.

ABDECKUNG: nicht abziehbar.

EIGENSTOFF: Vom Kunden bereitgestellter Stoff umfasst kein Leder. Für den benötigten Stoffverbrauch siehe Preisliste.

ESTRUCTURA: en madera, en los acabados ofrecidos.

ASIENTO Y RESPALDO: en poliuretano expandido.

REVESTIMIENTO: no desfundable.

TELA CLIENTE: El tejido proporcionado por el cliente no incluye pieles. Para el metraje, consulte la lista de precios.

HULL LOUNGE

poltrona
armchair
fauteuil
Sessel
sillón

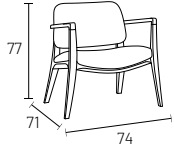

L W	H H	P D	CODICE CODE	Basic	Start	Extra	Light	Super	K	W	t-cliente com-fabric	ml l.mt.	m ³ kg
--------	--------	--------	----------------	-------	-------	-------	-------	-------	---	---	-------------------------	-------------	----------------------

74	77	71	DI02HU001	1.160	1.183	1.206	1.222	1.263	1.365	1.472	1.109	1,4	0,6 22
----	----	----	-----------	-------	-------	-------	-------	-------	-------	-------	-------	-----	-----------

LE MANS LOUNGE

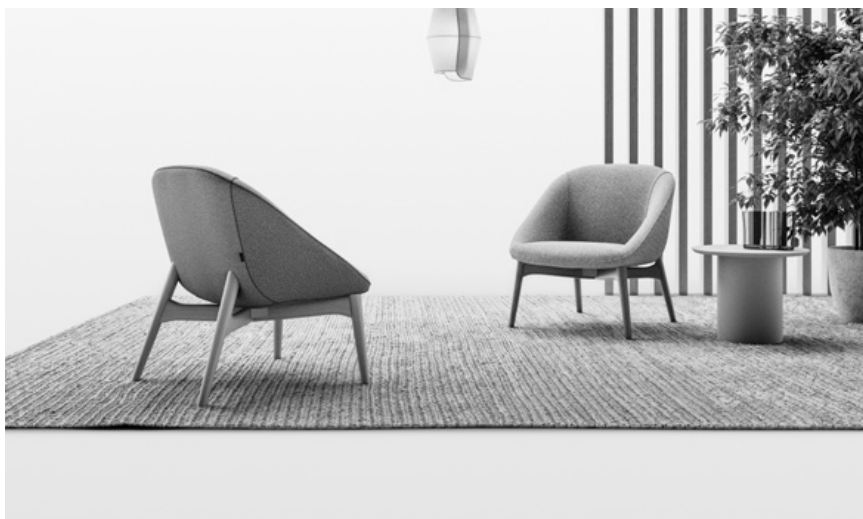

STRUTTURA, SCHIENALE E SEDUTA: in multistrato curvato rivestito in poliuretano espanso.

BASAMENTO: in legno nelle finiture essenza.

RIVESTIMENTO: non sfoderabile.

TESSUTO CLIENTE: il tessuto cliente non comprende le pelli. Per la metratura vedi listino.

STRUCTURE, BACK AND SEAT: in curved-shaped plywood covered with polyurethane foam.

BASE: in the wood finishes.

UPHOLSTERY: non removable.

CUSTOMER FABRIC: Customer fabric does not include leather. For the required linear metres, see the price list.

STRUCTURE, DOSSIER ET ASSISE: en multiplis courbé revêtu de polyuréthane expansé.

SUPPORT: en bois.

REVÊTEMENT: non déhoussable.

TISSU CLIENT: le tissu client n'inclut pas les cuirs. Pour le métrage, voir le tarif.

AUFBAU, RÜCKENLEHNE UND SITZFLÄCHE: aus gebogenem Sperrholz, beschichtet mit Polyurethanschaum beschichtet.

UNTERTEIL: aus Holz, in den verfügbaren Ausführungen

ABDECKUNG: nicht abziehbar.

EIGENSTOFF: Vom Kunden bereitgestellter Stoff umfasst kein Leder. Für den benötigten Stoffverbrauch siehe Preisliste.

ESTRUCTURA, RESPALDO Y ASIENTO: en multicapa curvada revestida con poliuretano expandido.

BASE: en madera, en los acabados ofrecidos.

REVESTIMIENTO: no desenfundable.

TELA CLIENTE: El tejido proporcionado por el cliente no incluye pieles. Para el metraje, consulte la lista de precios.

LE MANS LOUNGE

poltrona
armchair
fauteuil
Sessel
sillón

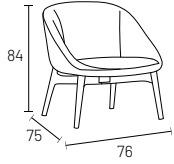

L W	H H	P D	CODICE CODE	Basic	Start	Extra	Light	Super	K	W	t-cliente com-fabric	ml l.mt.	m ³ kg
--------	--------	--------	----------------	-------	-------	-------	-------	-------	---	---	-------------------------	-------------	----------------------

76	84	75	DI02LM001	1.085	1.126	1.167	1.195	1.268	1.417	1.592	993	2,5	0,6 25
----	----	----	-----------	-------	-------	-------	-------	-------	-------	-------	-----	-----	-----------

MADAME



STRUTTURA E SCHIENALE: costruiti in schiumato.

SEDUTA: imbottita in poliuretano espanso.

BASAMENTO: in metallo verniciato nero. Disponibile in champagne, titanio o laccato opaco con maggiorazione: 25€ cadauno.

RIVESTIMENTO: non sfoderabile.

TESSUTO CLIENTE: il tessuto cliente non comprende le pelli. Per la metratura vedi listino.

STRUCTURE AND BACK: made of molded foam.

SEAT: padded with expanded polyurethane foam

BASE: in black varnished metal. Also available in champagne, titanium, or matte lacquered with an additional charge of €25 each feet.

UPHOLSTERY: non removable.

CUSTOMER FABRIC: Customer fabric does not include leather. For the required linear metres, see the price list.

STRUCTURE ET DOSSIER: construits en mousse.

ASSISE: rembourré en polyuréthane expansé.

SUPPORT: en métal laqué en noir. Disponible en champagne, titane ou laqué mat avec supplément : 25 € chacun.

REVÊTEMENT: non déhoussable.

TISSU CLIENT: le tissu client n'inclut pas les cuirs. Pour le métrage, voir le tarif.

AUFBAU UND RÜCKENLEHNE: Aus Schaumstoff gebaut.

SITZFLÄCHE: mit Polyurethanschaum gepolstert.

UNTERTEIL: aus schwarz lackiertem Metall. Auch in Ausführung Champagne, Titanio oder Mattlack gegen Aufpreis von 25 € pro Fuß.

ABDECKUNG: nicht abziehbar.

EIGENSTOFF: Vom Kunden bereitgestellter Stoff umfasst kein Leder. Für den benötigten Stoffverbrauch siehe Preisliste.

ESTRUCTURA Y RESPALDO: fabricados en espuma.

ASIENTO: acolchado con poliuretano expandido.

BASE: en metal lacado negro. Disponible en champagne, titanio o lacado mate con recargo de 25 € cada uno.

REVESTIMIENTO: no desenfundable.

TELA CLIENTE: El tejido proporcionado por el cliente no incluye pieles. Para el metraje, consulte la lista de precios.

MADAME

poltrona
armchair
fauteuil
Sessel
sillón

L W	H H	P D	CODICE CODE	Basic	Start	Extra	Light	Super	K	W	t-cliente com-fabric	ml l.mt.	m ³ kg
--------	--------	--------	----------------	-------	-------	-------	-------	-------	---	---	-------------------------	-------------	----------------------

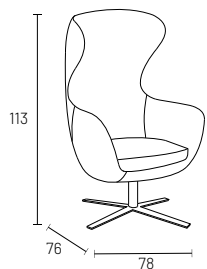

78	113	76	DI02MD001	1.232	1.294	1.355	1.396	1.484	2.049	2.444	1.096	4	0,68 30
----	-----	----	-----------	-------	-------	-------	-------	-------	-------	-------	-------	---	------------

Basamento standard verniciato nero, disponibile in champagne, titanio o laccato opaco con maggiorazione: 25 €. | Standard base painted black, also available in champagne, titanium, or matte lacquered with an additional charge of € 25. | Support standard laqué en noir, disponibles en champagne, titane ou laqué mat avec supplément : 25 €. | Standard Unterteil in schwarz lackiert, auch in Ausführung Champagne, Titanio oder Mattlack gegen Aufpreis von 25 €. | Base estándar pintados en negro, disponibles en champagne, titanio o lacado mate con un recargo de 25 €.



STRUTTURA: costruita in abete massello e multistrato e rivestita in poliuretano espanso. Parti secondarie e non strutturali in pannelli di fibre di legno.

SEDUTA: imbottita in poliuretano espanso ad alta densità e ricoperto con lenta memoria.

SCHIENALE E BRACCIOLI: imbottito in piuma d'oca e fiocco.

CORDONCINO: standard in bordino cannettato o con lo stesso tessuto del rivestimento.

PIEDINI: in metallo verniciato nero. Disponibili in champagne, titanio o laccato opaco con maggiorazione: 25€ cadauno.

RIVESTIMENTO: sfoderabile in tessuto, parzialmente sfoderabile nella versione in pelle (solo cuscinate).

TESSUTO CLIENTE: il tessuto cliente non comprende le pelli. Per la metratura vedi listino.

STRUCTURE: made of solid spruce and plywood and covered with expanded polyurethane. Secondary and non-structural parts in fibreboard panels.

SEAT: padded with high density expanded polyurethane foam and covered with slow-memory foam layer.

BACKREST AND ARMRESTS: padded with goose down and fiberfill.

RIBBON EDGE: standard with ribbed piping or in the same fabric as the upholstery.

FEET: in black varnished metal. Also available in champagne, titanium, or matte lacquered with an additional charge of €25 each feet.

UPHOLSTERY: removable cover in the fabric version, partially removable in the leather version (cushions only).

CUSTOMER FABRIC: Customer fabric does not include leather. For the required linear metres, see the price list.

STRUCTURE: construite en sapin massif et contreplaqué et rembourrée en polyuréthane expansé. Parties secondaires et non structurelles en panneaux de fibres de bois.

ASSISE: rembourrés en polyuréthane expansé à haute densité et recouverts de mousse à mémoire lente.

DOSSIER ET ACCOUDOIRS: rembourré en plume d'oise et flocon.

CORDON: standard avec passepoil côtelé ou avec le même tissu que le revêtement.

PIEDS: en métal laqué en noir. Disponibles en champagne, titane ou laqué mat avec supplément : 25 € chacun.

REVÊTEMENT: tissu déhoussable, partiellement déhoussable en version cuir (seulement les coussins).

TISSU CLIENT: le tissu client n'inclut pas les cuirs. Pour le métrage, voir le tarif.

STRUKTUR: Fichte massiv und kaschierter Stoff, mit Polyurethanschaum. Nicht Teile aus Holzfaserplatten.

SITZFLÄCHE: gepolstert aus Polyurethanschaum, mit strapazierfähigem Material bezogen.

RÜCKENLEHNE UND ARMLEHNEN: gepolstert aus Gänsedaunen und Schleife.

STOFFBORDE: standard Stoffborde Typ cannété oder mit dem gleichen Stoff des Bezuges.

FÜSSE: aus schwarz lackiertem Metall. Erhältlich auch in Champagne, Titan oder Mattlack gegen Aufpreis von 25 € pro Fuß.

ABDECKUNG: Vollständig abziehbar in der Stoffversion, bei der Lederversion teilweise abnehmbar (nur Kissen).

EIGENSTOFF: Vom Kunden bereitgestellter Stoff umfasst kein Leder. Für den benötigten Stoffverbrauch siehe Preisliste.

ESTRUCTURA: construido en abeto macizo y multicapa y revestido con poliuretano expandido. Partes secundarias y no estructurales en paneles de fibra de madera.

ASIENTO: acolchado con poliuretano expandido de alta densidad y revestida con espuma viscoelástica.

RESPALDO Y BRAZOS: acolchado con pluma de oca y copo.

FRANJA: estándar franja en cannété o con el mismo tejido del revestimiento.

PATAS: en metal lacado negro. Disponibles en champagne, titanio o lacado mate con recargo de 25 € cada uno.

REVESTIMIENTO: desenfundable en la versión tejido, parcialmente desenfundable en la versión piel (solo cojines).

TELA CLIENTE: El tejido proporcionado por el cliente no incluye pieles. Para el metraje, consulte la lista de precios.

MILTON

poltrona
armchair
fauteuil
Sessel
sillón

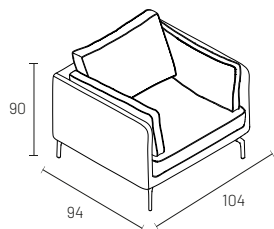

L W	H H	P D	CODICE CODE	Basic	Start	Extra	Light	Super	K	W	t-cliente com-fabric	ml l.mt.	m ³ kg
--------	--------	--------	----------------	-------	-------	-------	-------	-------	---	---	-------------------------	-------------	----------------------

104	90	94	DI01MIMA000	2.123	2.228	2.333	2.403	2.590	3.290	3.848	1.942	6,5	0,53 35
-----	----	----	-------------	-------	-------	-------	-------	-------	-------	-------	-------	-----	------------

Piedini standard verniciati neri, disponibili in champagne, titanio o laccato opaco con maggiorazione: 25 € cadauno. | Standard feet painted black, also available in champagne, titanium, or matte lacquered with an additional charge of € 25 each. | Pieds standard laqué en noir, disponibles en champagne, titane ou laqué mat avec supplément : 25 € chacun. | Standardfüße schwarz lackiert, erhältlich in Champagne, Titan oder Mattlack gegen Aufpreis von 25 € pro Fuß. | Patas estándar pintados en negro, disponibles en champagne, titanio o lacado mate con un recargo de 25 € cada uno.

PANAMA



STRUTTURA: costruita in abete massello e multistrato e rivestita in poliuretano espanso. Parti secondarie e non strutturali in pannelli di fibre di legno.

SEDUTA E SCHIENALE: imbottita in poliuretano espanso ad alta densità e ricoperto con lenta memoria.

CORDONCINO: standard in bordino cannettato o con lo stesso tessuto del rivestimento.

PIEDINI: in metallo verniciato nero. Disponibili in champagne, titanio o laccato opaco con maggiorazione: 25€ cadauno.

RIVESTIMENTO: sfoderabile in tessuto, parzialmente sfoderabile nella versione in pelle (solo cuscinate).

TESSUTO CLIENTE: il tessuto cliente non comprende le pelli. Per la metratura vedi listino.

STRUCTURE: made of solid spruce and plywood and covered with expanded polyurethane. Secondary and non-structural parts in fibreboard panels.

SEAT AND BACKREST: padded with high density expanded polyurethane foam and covered with slow-memory foam layer.

RIBBON EDGE: standard with ribbed piping or in the same fabric as the upholstery.

FEET: in black varnished metal. Also available in champagne, titanium, or matte lacquered with an additional charge of €25 each feet.

UPHOLSTERY: removable cover in the fabric version, partially removable in the leather version (cushions only).

CUSTOMER FABRIC: Customer fabric does not include leather. For the required linear metres, see the price list.

STRUCTURE: construite en sapin massif et contreplaqué et rembourrée en polyuréthane expansé. Parties secondaires et non structurelles en panneaux de fibres de bois.

ASSISE ET DOSSIER: rembourrés en polyuréthane expansé à haute densité et recouverts de mousse à mémoire lente.

CORDON: standard avec passepoil côtelé ou avec le même tissu que le revêtement.

PIEDS: en métal laqué en noir. Disponibles en champagne, titane ou laqué mat avec supplément : 25 € chacun.

REVÊTEMENT: tissu déhoussable, partiellement déhoussable en version cuir (seulement les coussins).

TISSU CLIENT: le tissu client n'inclut pas les cuirs. Pour le métrage, voir le tarif.

STRUKTUR: Fichte massiv und kaschierter Stoff, mit Polyurethanschäum. Nicht Teile aus Holzfasernplatten.

SITZFLÄCHE UND RÜCKENLEHNE: gepolstert aus Polyurethanschäum, mit strapazierfähigem Material bezogen.

STOFFBORDE: standard Stoffborde Typ cannété oder mit dem gleichen Stoff des Bezuges.

FÜSSE: aus schwarz lackiertem Metall. Erhältlich auch in Champagne, Titan oder Mattlack gegen Aufpreis von 25 € pro Fuß.

ABDECKUNG: Vollständig abziehbar in der Stoffversion, bei der Lederversion teilweise abnehmbar (nur Kissen).

EIGENSTOFF: Vom Kunden bereitgestellter Stoff umfasst kein Leder. Für den benötigten Stoffverbrauch siehe Preisliste.

ESTRUCTURA: construido en abeto macizo y multicapa y revestido con poliuretano expandido. Partes secundarias y no estructurales en paneles de fibra de madera.

ASIENTO Y RESPALDO: acolchado con poliuretano expandido de alta densidad y revestida con espuma viscoelástica.

FRANJA: estándar franja en cannété o con el mismo tejido del revestimiento.

PATAS: en metal lacado negro. Disponibles en champagne, titanio o lacado mate con recargo de 25 € cada uno.

REVESTIMIENTO: desenfundable en la versión tejido, parcialmente desenfundable en la versión piel (solo cojines).

TELA CLIENTE: El tejido proporcionado por el cliente no incluye pieles. Para el métraje, consulte la lista de precios.

PANAMA

poltrona
armchair
fauteuil
Sessel
sillón

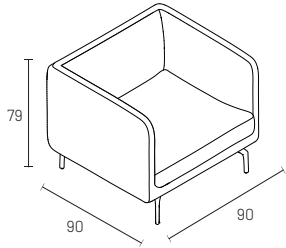

L W	H H	P D	CODICE CODE	Basic	Start	Extra	Light	Super	K	W	t-cliente com-fabric	ml l.mt.	m ³ kg
--------	--------	--------	----------------	-------	-------	-------	-------	-------	---	---	-------------------------	-------------	----------------------

90	79	90	DI01PAMA000	2.085	2.204	2.323	2.402	2.613	3.395	4.027	1.871	5,3	0,6 35
----	----	----	-------------	-------	-------	-------	-------	-------	-------	-------	-------	-----	-----------

Piedini standard verniciati neri, disponibili in champagne, titanio o laccato opaco con maggiorazione: 25 € cadauno. | Standard feet painted black, also available in champagne, titanium, or matte lacquered with an additional charge of € 25 each. | Pieds standard laqué en noir, disponibles en champagne, titane ou laqué mat avec supplément : 25 € chacun. | Standardfüße schwarz lackiert, erhältlich in Champagne, Titan oder Mattlack gegen Aufpreis von 25 € pro Fuß. | Patas estándar pintados en negro, disponibles en champagne, titanio o lacado mate con un recargo de 25 € cada uno.

PLANKA



STRUTTURA E SCHIENALE: multistrato curvato rivestito in poliuretano espanso.

SEDUTA: legno rivestito in poliuretano espanso.

PIEDINI: regolabili in altezza.

RIVESTIMENTO: non sfoderabile.

TESSUTO CLIENTE: il tessuto cliente non comprende le pelli. Per la metratura vedi listino.

STRUCTURE AND BACK: curved-shaped plywood covered with polyurethane foam.

SEAT: wood covered with polyurethane foam.

FEET: height-adjustable.

UPHOLSTERY: non removable.

CUSTOMER FABRIC: Customer fabric does not include leather. For the required linear metres, see the price list.

STRUCTURE ET DOSSIER: multiplis courbé revêtu de polyuréthane expansé.

ASSISE: bois revêtu de polyuréthane expansé.

PIEDS: réglables en hauteur.

REVÊTEMENT: non déhoussable.

TISSU CLIENT: le tissu client n'inclut pas les cuirs. Pour le métrage, voir le tarif.

AUFBAU UND RÜCKENLEHNE: Gebogenes Sperrholz, beschichtet mit Polyurethanschaum beschichtet.

SITZFLÄCHE: Holz, beschichtet mit Polyurethanschaum.

FÜSSE: höhenverstellbar.

ABDECKUNG: nicht abziehbar.

EIGENSTOFF: Vom Kunden bereitgestellter Stoff umfasst kein Leder. Für den benötigten Stoffverbrauch siehe Preisliste.

ESTRUCTURA Y RESPALDO: multicapa curvada revestida con poliuretano expandido.

ASIENTO: Madera revestida con poliuretano expandido.

PATAS: ajustables en altura.

REVESTIMIENTO: no desenfundable.

TELA CLIENTE: El tejido proporcionado por el cliente no incluye pieles. Para el metraje, consulte la lista de precios.

PLANKA

poltrona
armchair
fauteuil
Sessel
sillón

L W	H H	P D	CODICE CODE	Basic	Start	Extra	Light	Super	K	W	t-cliente com-fabric	ml l.mt.	m ³ kg
--------	--------	--------	----------------	-------	-------	-------	-------	-------	---	---	-------------------------	-------------	----------------------

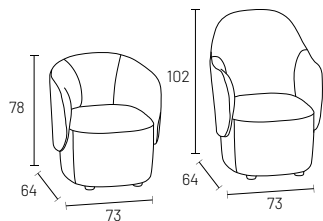

73	102	64	DI02PL001	1.601	1.688	1.776	1.834	1.961	2.542	3.012	1.406	4,5	0,69 22
73	78	64	DI02PL002	1.535	1.608	1.681	1.731	1.835	2.324	2.719	1.373	4	0,58 20

poggiapiedi
footrest
repose-pieds
Fußstütze
reposapiés

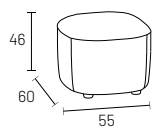

55	46	60	DI02PL010	651	687	723	748	800	1.066	1.272	570	2	0,21 11
----	----	----	-----------	-----	-----	-----	-----	-----	-------	-------	-----	---	------------

SUPERNOVA



STRUTTURA E SCHIENALE: multistrato curvato rivestito in poliuretano espanso.

SEDUTA: in poliuretano espanso.

BASAMENTO: in metallo verniciato nero. Disponibile in champagne, titanio, laccato opaco o RAL con maggiorazione: 25€ cadauno.

RIVESTIMENTO: non sfoderabile.

TESSUTO CLIENTE: il tessuto cliente non comprende le pelli. Per la metratura vedi listino.

STRUCTURE AND BACK: curved-shaped plywood covered with polyurethane foam.

SEAT: in expanded polyurethane foam.

BASE: in black varnished metal. Also available in champagne, titanium, matte or RAL lacquered with an additional charge of €25 each feet.

UPHOLSTERY: non removable.

CUSTOMER FABRIC: Customer fabric does not include leather. For the required linear metres, see the price list.

STRUCTURE ET DOSSIER: multiplis courbé revêtu de polyuréthane expansé.

ASSISE: en polyuréthane expansé.

SUPPORT: en métal laqué en noir. Disponibles en champagne, titane laqué mat ou RAL avec supplément : 25 € chacun.

REVÊTEMENT: non déhoussable.

TISSU CLIENT: le tissu client n'inclut pas les cuirs. Pour le métrage, voir le tarif.

AUFBAU UND RÜCKENLEHNE: Gebogenes Sperrholz, beschichtet mit Polyurethanschaum beschichtet.

SITZFLÄCHE: aus Polyurethanschaum.

UNTERTEIL: aus schwarz lackiertem Metall. Auch erhältlich in Champagner, Titan matt lackiert oder RAL mit Aufpreis von 25 € pro Fuß.

ABDECKUNG: nicht abziehbar.

EIGENSTOFF: Vom Kunden bereitgestellter Stoff umfasst kein Leder. Für den benötigten Stoffverbrauch siehe Preisliste.

ESTRUCTURA Y RESPALDO: multicapa curvada revestida con poliuretano expandido.

ASIENTO: en poliuretano expandido.

BASE: en metal lacado negro. Disponible en champagne, titanio, lacado mate o RAL con recargo de 25 € cada uno.

REVESTIMIENTO: no desenfundable.

TELA CLIENTE: El tejido proporcionado por el cliente no incluye pieles. Para el metraje, consulte la lista de precios.

SUPERNOVA

poltrona
armchair
fauteuil
Sessel
sillón

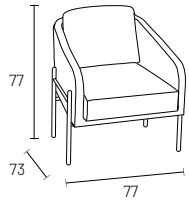

L W	H H	P D	CODICE CODE	Basic	Start	Extra	Light	Super	K	W	t-cliente com-fabric	ml l.mt.	m ³ kg
--------	--------	--------	----------------	-------	-------	-------	-------	-------	---	---	-------------------------	-------------	----------------------

77	77	73	DI02SU001	1.225	1.262	1.293	1.316	1.377	1.635	1.843	1.147	4,3	0,6 22
----	----	----	-----------	-------	-------	-------	-------	-------	-------	-------	-------	-----	-----------

Piedini standard verniciati neri, disponibili in champagne, titanio, laccato opaco o RAL con maggiorazione: 25 € cadauno. | Standard feet painted black, also available in champagne, titanium, matte or RAL lacquered with an additional charge of € 25 each. | Pieds standard laqué en noir, disponibles en champagne, titane laqué mat ou RAL avec supplément : 25 € chacun. | Standardfüße schwarz lackiert, erhältlich in Champagner, Titan, matt lackiert oder RAL mit Aufpreis von 25 € pro Fuß. | Patas estándar pintados en negro, disponibles en champagne, titanio, lacado mate o RAL con un recargo de 25 € cada uno.

POUF | POUF | POUF | POUF | POUF

BESU

pouf quadrato
square pouf
pouf carré
quadratischer Hocker
pouf cuadrado

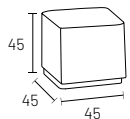

L W	H H	P D	CODICE CODE	Basic	Start	Extra	Light	Super	K	W	t-cliente com-fabric	ml l.mt.	m³ kg
--------	--------	--------	----------------	-------	-------	-------	-------	-------	---	---	-------------------------	-------------	----------

45	45	45	DBQ04544	530	559	591	610	652	880	1.050	465	1,8	0,1 8,5
----	----	----	----------	-----	-----	-----	-----	-----	-----	-------	-----	-----	------------

pouf rettangolare
rectangular pouf
pouf rectangulaire
rechteckiger Hocker
pouf rectangular

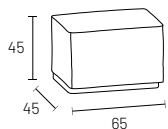

65	45	45	DBR06544	730	761	790	811	853	1.079	1.251	664	2,1	0,15 12,5
----	----	----	----------	-----	-----	-----	-----	-----	-------	-------	-----	-----	--------------

pouf Ø 45
pouf Ø 45
pouf Ø 45
Hocker Ø 45
pouf Ø 45

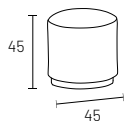

45	45	45	DBT04544	559	590	619	638	682	908	1.079	494	1,8	0,1 8,5
----	----	----	----------	-----	-----	-----	-----	-----	-----	-------	-----	-----	------------

pouf Ø 90
pouf Ø 90
pouf Ø 90
Hocker Ø 90
pouf Ø 90

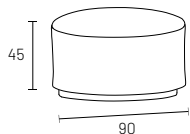

90	90	45	DBT09049	1.275	1.305	1.335	1.354	1.397	1.624	1.795	1.210	2,5	0,4 27
----	----	----	----------	-------	-------	-------	-------	-------	-------	-------	-------	-----	-----------

SUPERNOVA

pouf Ø 45
 pouf Ø 45
 pouf Ø 45
 Hocker Ø 45
 pouf Ø 45

L	H	P	CODICE	Basic	Start	Extra	Light	Super	K	W	t-cliente	ml	m³
W	H	D	CODE								com-fabric	l.mt.	kg

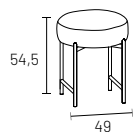

49	54,5	49	DSN0049	436	452	467	479	503	629	725	399	1	0,14 7
----	------	----	---------	-----	-----	-----	-----	-----	-----	-----	-----	---	-----------

pouf Ø 60
 pouf Ø 60
 pouf Ø 60
 Hocker Ø 60
 pouf Ø 60

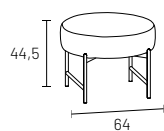

64	44,5	64	DSN0064	501	526	551	567	603	791	934	446	1,5	0,2 10
----	------	----	---------	-----	-----	-----	-----	-----	-----	-----	-----	-----	-----------

pouf Ø 75
 pouf Ø 75
 pouf Ø 75
 Hocker Ø 75
 pouf Ø 75

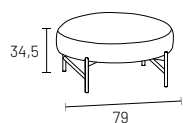

79	34,5	79	DSN0079	598	631	663	686	733	985	1.176	525	2	0,24 12,5
----	------	----	---------	-----	-----	-----	-----	-----	-----	-------	-----	---	--------------

pouf Ø 75 con vassoio girevole
 pouf Ø 75 with swivel tray
 pouf Ø 75 avec plateau pivotante
 Hocker Ø 75 mit drehbarem Tablett
 pouf Ø 75 con bandeja giratoria

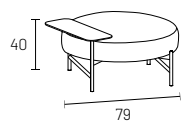

79	40	79	DSN0079V	839	871	905	927	973	1.225	1.416	766	2	0,28 15,7
----	----	----	----------	-----	-----	-----	-----	-----	-------	-------	-----	---	--------------

Piedini standard verniciati neri, disponibili in champagne, titanio o laccato opaco con maggiorazione: 25 € cadauno. | Standard feet painted black, also available in champagne, titanium, or matte lacquered with an additional charge of € 25 each. | Pieds standard laqué en noir, disponibles en champagne, titane ou laqué mat avec supplément : 25 € chacun. | Standardfüße schwarz lackiert, erhältlich in Champagne, Titan oder Mattlack gegen Aufpreis von 25 € pro Fuß. | Patas estándar pintados en negro, disponibles en champagne, titanio o lacado mate con un recargo de 25 € cada uno.

SUPERNOVA

pouf Ø 140
 pouf Ø 140
 pouf Ø 140
 Hocker Ø 140
 pouf Ø 140

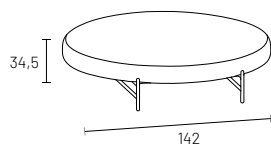

L	H	P	CODICE
W	H	D	CODE

Basic	Start	Extra	Light	Super	K	W	t-cliente	ml	m³
							com-fabric	l.mt.	kg

142	34,5	142	DSN0142	1.118	1.167	1.217	1.249	1.321	1.699	1.985	1.008	3	0,77 46
-----	------	-----	---------	-------	-------	-------	-------	-------	-------	-------	-------	---	------------

panca L 120
 bench L 120
 banc L 120
 Sitzbank B 120
 banqueta a.120

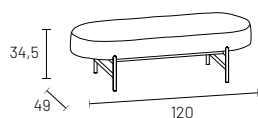

120	34,5	49	DSN0120	605	630	655	672	707	895	1.039	551	1,5	0,22 15
-----	------	----	---------	-----	-----	-----	-----	-----	-----	-------	-----	-----	------------

panca L 160
 bench L 160
 banc L 160
 Sitzbank B 160
 banqueta a.160

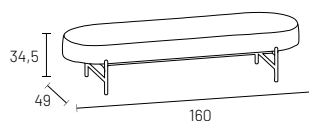

160	34,5	49	DSN0160	778	808	838	857	902	1.127	1.298	713	1,8	0,3 21
-----	------	----	---------	-----	-----	-----	-----	-----	-------	-------	-----	-----	-----------

Piedini standard verniciati neri, disponibili in champagne, titanio o laccato opaco con maggiorazione: 25 € cadauno. | Standard feet painted black, also available in champagne, titanium, or matte lacquered with an additional charge of € 25 each. | Pieds standard laqué en noir, disponibles en champagne, titane ou laqué mat avec supplément : 25 € chacun. | Standardfüße schwarz lackiert, erhältlich in Champagne, Titan oder Mattlack gegen Aufpreis von 25 € pro Fuß. | Patas estándar pintados en negro, disponibles en champagne, titanio o lacado mate con un recargo de 25 € cada uno.

CONDIZIONI GENERALI DI VENDITA | GENERAL SALES CONDITIONS

CONDIZIONI GENERALI: La fornitura si intende ai prezzi indicati nel listino ed alle condizioni generali di vendita in vigore, che si intendono conosciute ed accettate dal Cliente. I prezzi indicati nel listino, espressi in euro, sono al netto di iva, installazione e/o qualsiasi prestazione ulteriore. Gli eventuali lavori "fuori misura", se non già regolamentati nel listino, qualora approvati da DA group s.r.l. verranno quotati e valorizzati caso per caso. Le proposte d'ordine si intendono accettate "salvo approvazione della casa", che DA group s.r.l. si riserva di dare a proprio esclusivo ed insindacabile giudizio.

TERMINI DI CONSEGNA: I termini di consegna comunicati al Cliente non possono considerarsi vincolanti in quanto sono subordinati ai tempi di produzione e/o alla disponibilità della merce a magazzino. Qualora per causa di forza maggiore venga previsto un ritardo rispetto ai termini di consegna comunicati verrà concordato tra le parti un nuovo termine. Viene escluso sin d'ora che i ritardi possano dare diritto a qualsiasi risarcimento danni, diretto o indiretto, o annullamento dell'ordine.

SPEDIZIONI: Per consegne di ordini con importo netto inferiore a € 500,00, per l'Italia, e € 750,00 per l'estero, viene applicato un contributo forfettario pari a € 50,00 per l'Italia e € 75,00 per l'estero. La merce viaggia a rischio e pericolo del Cliente quando venduta franco fabbrica. In caso di consegna richiesta in un luogo diverso dal punto di vendita o magazzino dell'acquirente, sarà applicato un supplemento di prezzo, quantificato caso per caso. Resta inteso che la merce viene sempre consegnata "sponda camion". Il Cliente è tenuto ad ispezionare accuratamente la merce ricevuta ed eventuali reclami riguardanti danni subiti durante il trasporto dovranno essere immediatamente segnalati al vettore ed annotati sul documento di trasporto; reclami riguardanti la qualità della merce e/o eventuali difetti di fabbricazione e/o difformità rispetto all'ordine dovranno pervenire entro e non oltre otto giorni dalla consegna a DA group s.r.l. a mezzo raccomandata a.r. Trascorso tale periodo DA group s.r.l. declina qualsiasi propria responsabilità. In relazione ai reclami rivolti nei modi e nei tempi sopra descritti si precisa, comunque, che non si accetteranno resi di merce se non debitamente autorizzati da DA group s.r.l.

SOSTITUZIONI E RESI: La merce, qualora sostituita, dovrà essere immediatamente resa disponibile correttamente imballata dal Cliente, all'atto della sostituzione stessa. Qualora, per qualsiasi motivo, la merce sostituita non fosse resa disponibile, DA group s.r.l. si riserva trascorsi 30 giorni dalla sostituzione, il diritto di esigerne il pagamento. I resi accettati saranno valutati al prezzo pagato dal Cliente e, se non in buono stato di conservazione, al valore riconosciuto ad insindacabile giudizio dell'ufficio tecnico DA group s.r.l. Si precisa che anche nel caso di reclami effettuati entro i termini i pagamenti non potranno essere sospesi. Per le lavorazioni eseguite "fuori misura" e/o personalizzate su richiesta del Cliente non si accettano nè resi né richieste di sostituzione.

DA group s.r.l. garantisce i propri prodotti da difetti occulti e per l'utilizzo cui il bene è destinato; i danni derivanti da incuria, negligenza e/o uso improprio non daranno diritto a reclami e/o richieste di danni, diretti o indiretti. Qualsiasi controversia che non fosse possibile risolvere in via bonaria tra le parti sarà devoluto all'unico Foro competente di Pordenone.

PAGAMENTI: Le modalità di pagamento ed i relativi termini sono quelli concordati previamente con DA group s.r.l. e così come risultanti nella relativa "scheda anagrafica". Sono ritenuti validi solo i pagamenti effettuati direttamente a DA group s.r.l. e/o a propri incaricati e/o propri agenti autorizzati. I titoli di credito eventualmente accettati lo sono sempre "salvo buon fine". Il ritardo nei pagamenti, anche di una sola rata, dà diritto a DA group s.r.l. di richiedere l'integrale pagamento del prezzo di vendita con l'aggravio degli interessi legali ed eventuali spese. La merce rimane di proprietà DA group s.r.l. fino all'avvenuto integrale pagamento del prezzo di vendita. Eventuali insolvenze o ritardi nei pagamenti in scadenza da parte del Cliente relativamente a forniture già effettuate, daranno facoltà a DA group s.r.l. di sospendere o annullare l'esecuzione degli ordini in corso anche se già accettati.

MODIFICHE AI PRODOTTI: In riferimento al continuo miglioramento tecnologico del prodotto, DA group s.r.l. si riserva il diritto di apportare le modifiche ritenute più opportune alla modellistica, che non abbiano ad incidere negativamente sulla qualità e sull'estetica del prodotto stesso e ciò a proprio insindacabile giudizio e senza la necessità di un preavviso. I colori delle parti verniciate e delle essenze sono indicativi in quanto non è tecnicamente possibile mantenere le stesse tonalità di colore nel tempo; si declina, pertanto, ogni responsabilità per richieste di accoppiamento pervenute in tempi diversi anche se DA group s.r.l. si adopererà a fornire la migliore soluzione tecnica possibile. È facoltà di DA group s.r.l. di apportare, a proprio insindacabile giudizio, in qualsiasi momento e senza preavviso, tutte le variazioni che riterrà necessarie, alle caratteristiche tecniche, costruttive, estetiche dei propri modelli, nonché ai prezzi indicati nel presente listino. I cataloghi e dépliant in circolazione hanno valore puramente illustrativo, eventuali inesattezze di stampa e/o di descrizione delle caratteristiche e/o indicazioni di misure non sostanziali dei prodotti non potranno dar luogo a responsabilità in capo a DA group s.r.l.

DIRITTO DI PROPRIETÀ: È vietata la pubblicità, con foto o con altri mezzi, della merce fornita senza la preventiva autorizzazione scritta di DA group s.r.l.

UTILIZZO DEL MARCHIO: È fatto divieto assoluto a tutti i clienti, salvo patto contrario, l'utilizzo del marchio "Dall'Agnese". In caso di accertata violazione DA group s.r.l. si riserva il diritto di agire giudizialmente per ottenere il riconoscimento dei danni.

GENERAL CONDITIONS: The supply is agreed accordingly to the prices specified in the price list and upon the general sales conditions in force, which the Customer is understood to have read and accepted. The prices specified in the price list, expressed in euros, are net of VAT, installation and/or any additional service. Any custom machining which is not already marked in the price list, if approved by DA group s.r.l., will be quoted and priced on individual basis. The orders are understood to be accepted "upon company approval", which DA group s.r.l. reserves the right to give at its sole and final discretion.

DELIVERY TERMS: The delivery dates notified to the Customer shall not be considered as binding, since they are subject to the production leadtime and/or availability of the stocks in the warehouse. In case of force majeure, if a delay is expected in relation to the notified delivery date, a new deadline will be agreed between parties. It is hereby specified that such delay shall not entitle the Customer to any damage compensation, direct or consequential, nor to the cancellation of the order.

SHIPMENTS: For deliveries of orders with a net amount less than € 500,00 for Italy, and € 750,00 for foreign countries, a flat-rate fee of € 50,00 for Italy and € 75,00 for foreign countries is charged. The goods are shipped at the Customer's risk and peril when the sale is arranged on ex-factory basis. If the delivery is required to a different location than the buyer's usual shop or warehouse, a charge will be calculated upon the specific case and supplied accordingly. It is understood that the the consignment of the goods is always carried as a "tailgate delivery". The Customer is bound to thoroughly inspect the goods received, and any claims concerning damages incurred during transport shall be reported immediately to the carrier and noted on the shipping document; claims concerning the quality of the goods and/or any manufacturing defects and/or discrepancies with respect to the order shall be forwarded to DA group s.r.l. within and no later than eight days upon the delivery by means of registered letter with return receipt. Once this period has expired, DA group s.r.l. shall accept no liability whatsoever. In regards to claims filed under the terms and conditions above established, however, it is specified that the returned goods will not be accepted unless duly authorized by DA group s.r.l.

REPLACEMENTS AND RETURNS: The goods, in case of replacement, shall be immediately released and duly packed by the same Customer upon the same return. If, for any reason, the replaced goods are not made available, DA group s.r.l. shall be entitled to require the payment of the goods 30 days upon the replacement. The accepted returns will be valued at the price paid by the Customer or, if not in a good preservation status, at the value acknowledged with the final decision of DA group s.r.l.'s Technical Department. It is specified that, even in the case of claims made within the terms, the payments cannot be suspended. For any bespoke machining and/or customizations executed upon Customer request, neither returns nor requests for replacement will be accepted.

DA group s.r.l. guarantees its products against hidden defects and for the use for which they have been designed; any damage resulting from neglect, negligence and/or improper use shall not entitle the customer to make complaints and/or claims for direct or consequential damages. Any dispute which cannot be resolved amicably between the parties shall be devolved to the exclusive jurisdiction of Pordenone.

PAYMENTS: Payment methods and relative terms shall be agreed beforehand with DA group s.r.l., in accordance to the personal data sheet. Only the payments made directly to DA group s.r.l. and/or its representatives and/or its authorized agents are considered as valid ones. Any credit instrument accepted is subject to clearance. Any delay in payments, even of a single instalment, entitles DA group s.r.l. to demand the full settlement of the sales price with the additional increase of legal costs and eventual extra charges. The goods remain full property of DA group s.r.l. until receipt of the entire payment of the sales price. Any insolvency or delays in the payments with reference to supplies already executed shall grant DA group s.r.l. the power to suspend or cancel the execution of the orders in progress, even if already accepted.

AMENDMENTS TO PRODUCTS: In regards to the continuous technological improvement of the product, DA group s.r.l. reserves the right to make any amendment considered as appropriate to the modelling, which shall have no negative impact on the quality or aesthetics of the product itself, at its sole and final discretion without the need for any prior notice. The colours of the painted parts and wood finishes are representative only, since it is not technically possible to maintain the same shades of colour over time; therefore DA group s.r.l. accepts no liability for matching requests received at different times even though DA group s.r.l. will work to provide the best technical solution possible. DA group s.r.l. has the faculty to make, at its sole and final discretion and at any time without prior notice, all the variations that may be considered necessary to the technical, constructional and/or aesthetic characteristics of its models, as well as the prices specified in this price list. The catalogues and brochures provided are representative only; any unsubstantial inaccuracy in the printing and/or description of the characteristics and/or measurement specifications of the products shall not give rise to liability on DA group s.r.l.'s side

PROPERTY RIGHTS: Any advertisement of the supplied furniture, by means of pictures or any other way, is forbidden without a previous written authorization by DA group s.r.l.

USE OF TRADEMARK: Except for different agreement, the use of "Dall'Agnese" trademark is absolutely forbidden to any customer. In case of ascertained violation, DA group s.r.l. reserves the right to take legal actions in order to obtain the acknowledgement of damages.

DA group Srl

Via Mazzini, 3
33070 Maron di Brugnera (PN) Italy

Reception: +39 0434 619111
Fax: +39 0434 624690
info@dallagnese.it

www.dallagnese.it



DA GROUP Srl

Via Mazzini, 3

33070 Maron di Brugnera (PN) Italy

Tel: +39 0434 619111 - Fax: +39 0434 624690

info@dallagnese.it - www.dallagnese.it