



M A T E R I C A







# MATERICA

**M**atter listens, breathes, narrates.

Materica is the collection by IVG Home Collection that celebrates the primal essence of things. Every surface, texture and detail reveals a unique character – a story waiting to be told.

The grain of the wood, the contours of the upholstered pieces, the surfaces smoothed by light, and the earthy tones create a perfect balance between nature and design.

Designed by Lucia Ippolito, the collection originates from the union of pure forms and expert craftsmanship.

Every detail expresses a balance of solidity and lightness. Textures become narrative, colours evoke tactile depth, and surfaces reflect the mastery of those who shape matter without betraying its essence. Soft, welcoming forms envelop the space, creating harmony between function and emotion.

Materica is a sensory experience, a transformation, a balance between nature and vision.

The collection draws inspiration from the beauty of nature, expressed through its colours, forms and handcrafted workmanship.

The result is a sophisticated furniture series, the work of talented designer Lucia Ippolito, with the aim of celebrating matter in its purest and most authentic forms, exploring the infinite possibilities of craftsmanship.

**L**a materia ascolta, respira, racconta.

Materica è la collezione IVG Home Collection che esalta la sostanza primordiale delle cose.

Ogni superficie, trama o dettaglio rivela un carattere unico, una storia da raccontare.

Le venature del legno, i volumi degli imbottiti, le superfici levigate dalla luce, le nuances della terra creano un equilibrio perfetto tra natura e design.

Firmata dalla designer Lucia Ippolito, la collezione nasce dall'incontro tra purezza delle forme e sapienza della lavorazione artigianale.

In ogni dettaglio si legge il dialogo tra solidità e leggerezza. Le texture diventano racconto, i colori evocano profondità tattili, le superfici rivelano la maestria di chi interpreta la materia senza tradirne l'essenza. Le forme morbide e accoglienti avvolgono lo spazio, creando armonia tra funzionalità ed emozione.

Materica è esperienza sensoriale, trasformazione, equilibrio tra natura e visione.

La collezione si ispira alla bellezza della natura nei colori, nelle forme, nelle lavorazioni artigianali.

Il risultato è una linea di arredi sofisticati nata dall'estro della talentuosa designer Lucia Ippolito con l'obiettivo di celebrare la materia nelle sue forme più pure e autentiche, esplorando le infinite possibilità della lavorazione.



# dune villa



comp\_01 10

comp\_02 38

comp\_03 66

comp\_04 86

# forest villa



comp\_05 106

comp\_06 134

comp\_07 160

**d** u n e v i l l a



living Dune 01

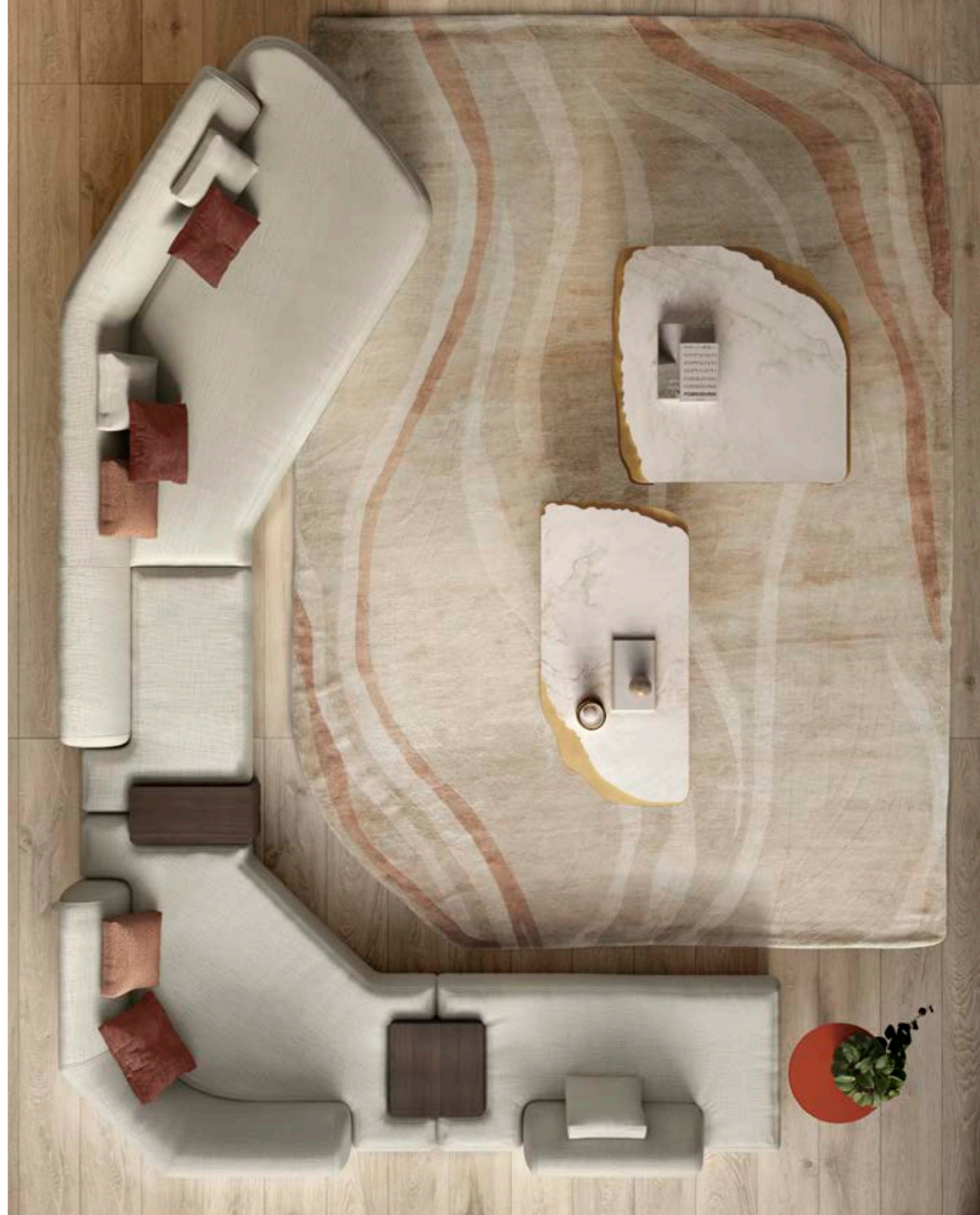

**F**lowing lines and harmonious contours shape an enveloping elegance. The sofa offers refined comfort. The side table combines the warmth of wood with the richness of marble creating a perfect balance between matter and form, function and beauty.

**L**inee fluide e volumi armoniosi disegnano un'eleganza avvolgente. Il divano offre un comfort raffinato. Il tavolino combina il calore del legno con la preziosità del marmo, creando un equilibrio perfetto tra materia e forma, funzionalità e bellezza.



**D**une  
sofa  
*divano*



**T**he same spirit, expressed through a versatile design. A wide range of upholstery options, including fabrics and leathers, allows every detail to be personalised and transformed into a unique piece.

**La** stessa anima in un'estetica versatile. Un'ampia gamma di rivestimenti, tra tessuti e pelli, per personalizzare ogni dettaglio e trasformarlo in un pezzo unico.



**D**une  
sofa  
*divano*



**C**urved lines and generous proportions give shape to an armchair with strong character, enhancing comfort with understated sophistication.

**L**inee avvolgenti e proporzioni generose danno vita ad una poltrona di carattere che esalta il comfort con raffinata semplicità.

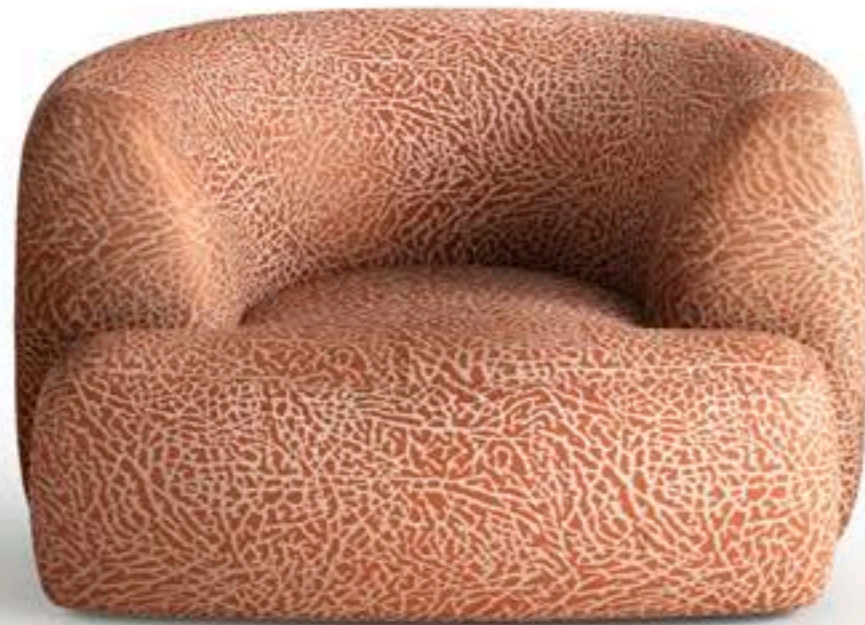

**D**une  
armchair  
*poltrona*



**N**ature-inspired forms give life to a side table that blends harmony and refinement. A sturdy metal frame, available in three finishes, highlights the authentic beauty of the stone surfaces.

**F**orme ispirate alla natura danno vita a un tavolino che unisce armonia e raffinatezza. Una solida struttura in metallo, proposta in tre finiture, esalta la bellezza autentica delle superfici in pietra.



**D**une  
coffee table  
*tavolino*



The timeless elegance of marble is paired with the subtle presence of an integrated drawer, elevated by refined finishes and exquisite detailing.

L'eleganza senza tempo del marmo si unisce alla discrezione di un cassetto integrato, valorizzato da finiture raffinate e dettagli preziosi.





**P**ure geometries and exclusive materials define a console marked by understated elegance. The solidity of stone merges with the lightness of glass and the brilliance of metal, striking a perfect balance between strength and refinement.

**G**eometrie pure e materiali ricercati definiscono una consolle dall'eleganza essenziale. La solidità della pietra si fonde con la leggerezza del vetro e la lucentezza del metallo, creando un equilibrio perfetto tra forza e raffinatezza.



**Y**uma  
console  
*consolle*

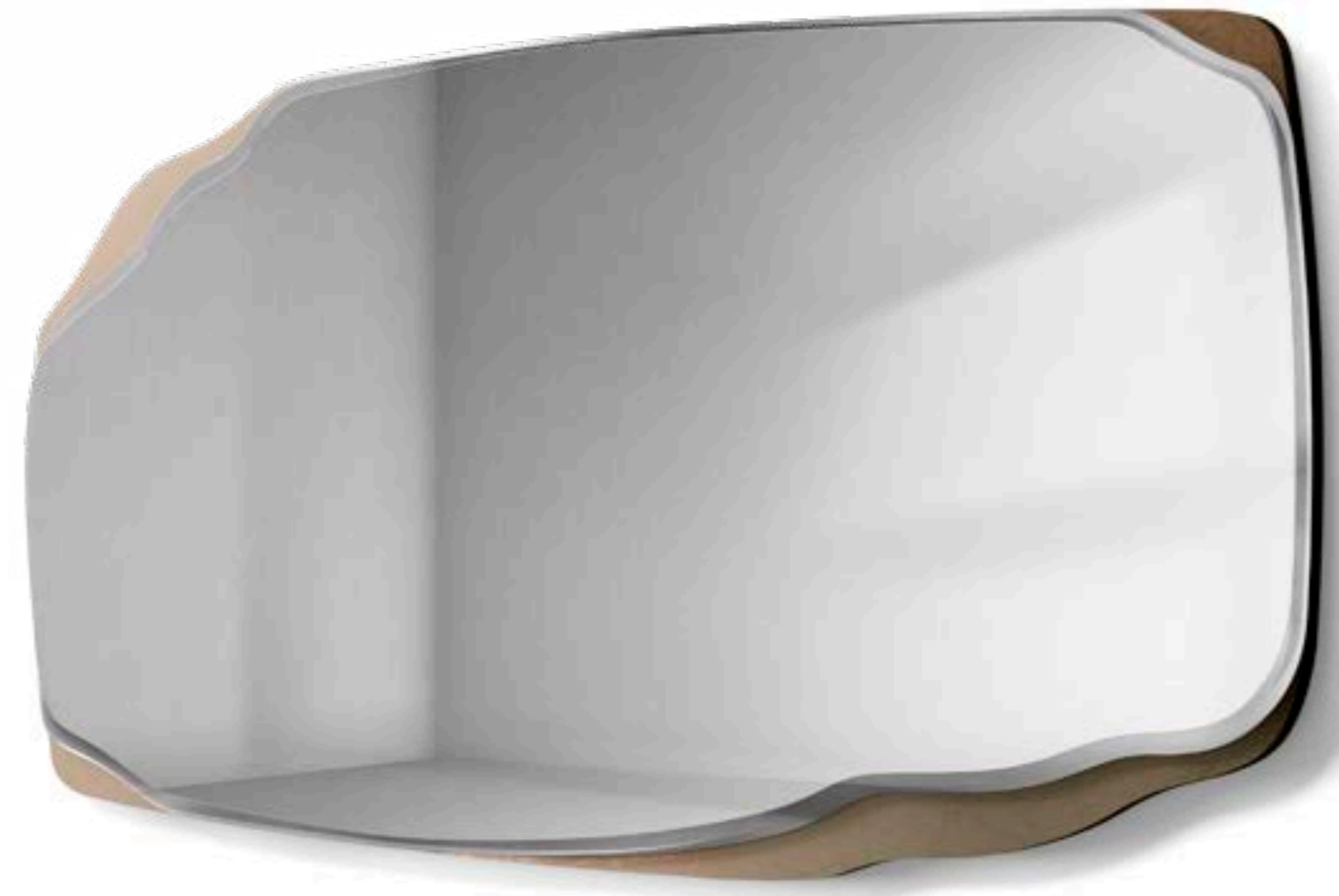

**D**une  
mirror  
*specchio*

**E**nveloping contours and a  
sculptural soul.

**L**inee avvolgenti e  
anima scultorea.



**S**ahara  
armchair  
*poltrona*





**G**lamis  
coffee and side table  
*tavolino centrale e laterale*



**T**ara  
low cabinet  
*mobile basso*





**s**ofa Glamis

Softness sculpted into fluid volumes.

Morbidezza scolpita in volumi fluidi.





**G**lamis  
sofa  
*divano*

**s**ofa Glamis

Flowing forms and embracing  
comfort highlight the harmony  
between matter and softness.

Forme sinuose  
e comfort avvolgente,  
esaltano l'equilibrio  
tra materia e morbidezza.





**T**ottori  
little armchair  
*poltoncina*



**Depth and texture.**

Clean lines and sculpted details echo the tones and curves of sand dunes.

**Profondità e matericità.**

Linee essenziali e dettagli scolpiti che richiamano le tonalità e le sinuosità delle dune.



**D**une  
console  
*consolle*

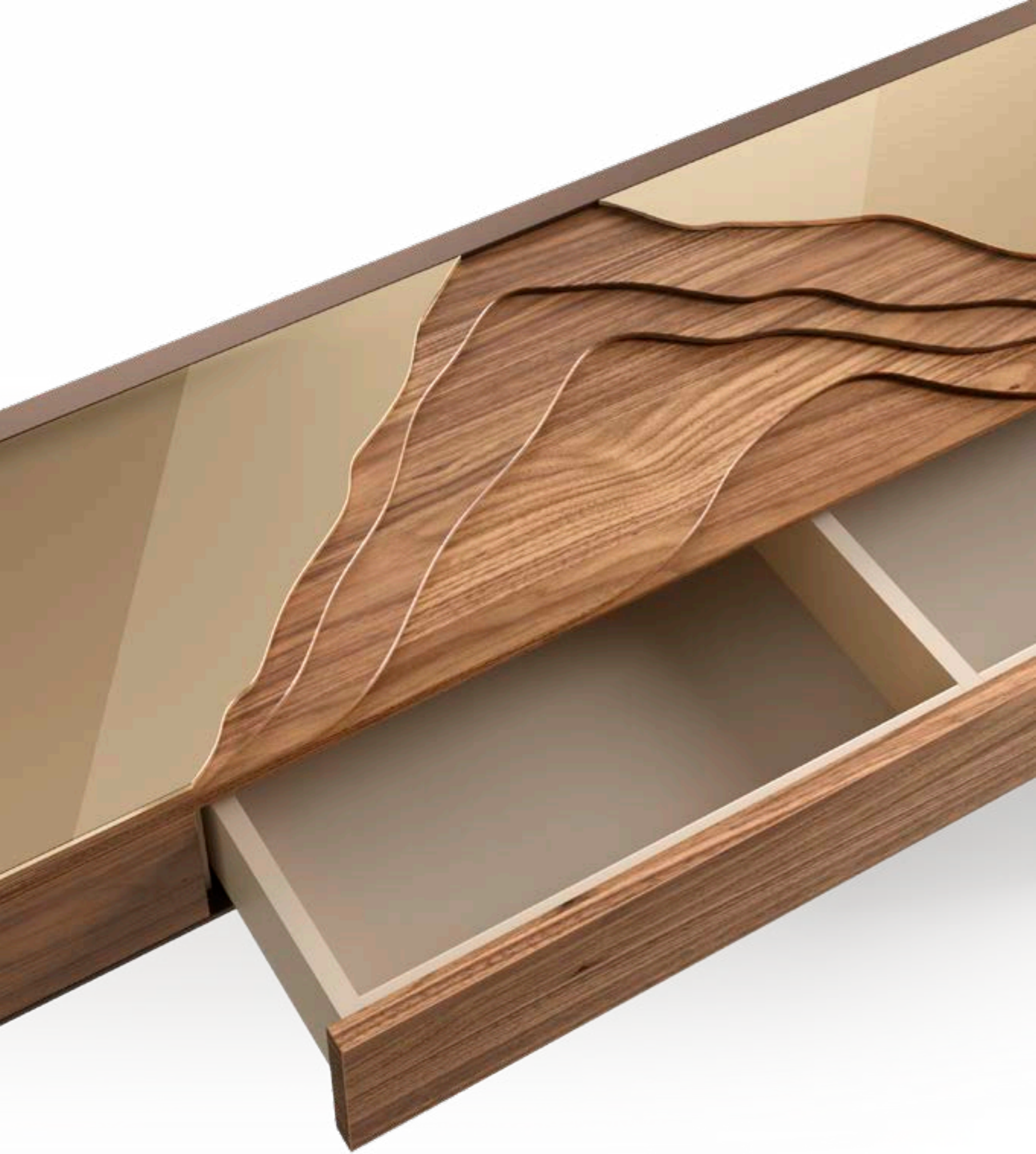

**F**orm merges with matter.  
The harmony of circular  
geometry meets the solidity  
of stone, with sharp cuts  
that lighten the structure  
and emphasise its sculptural  
purity.

**L**a forma si fonde con la  
materia.  
L'armonia della geometria  
circolare incontra la solidità  
della pietra, con tagli netti  
che donano leggerezza alla  
struttura e ne esaltano la  
purezza scultorea.



**G**ea  
coffee table  
*tavolino*



**C**lean lines and balanced proportions define a low table that plays with solids and voids. Metallic details heighten the interplay between surfaces and volumes, creating delicate reflections that amplify its visual lightness.

**L**inee essenziali e proporzioni equilibrate definiscono un tavolino basso che gioca con pieni e vuoti. I dettagli metallici esaltano l'incontro tra superfici e volumi, creando riflessi delicati che ne amplificano la leggerezza visiva.



**G**ea  
coffee table  
*tavolino*



**R**ock  
side table  
*tavolino*



**S**tone  
carpet  
*tappeto*

**d**ining area

A sensory experience  
beyond dining.  
Matter sculpted into pure  
volumes, surfaces that  
capture the light, and details  
that express the strength  
and elegance of nature.

Un'esperienza sensoriale  
oltre il dining.  
Materia scolpita in  
volumi puri, superfici che  
catturano la luce, dettagli  
che raccontano la forza e  
l'eleganza della natura.

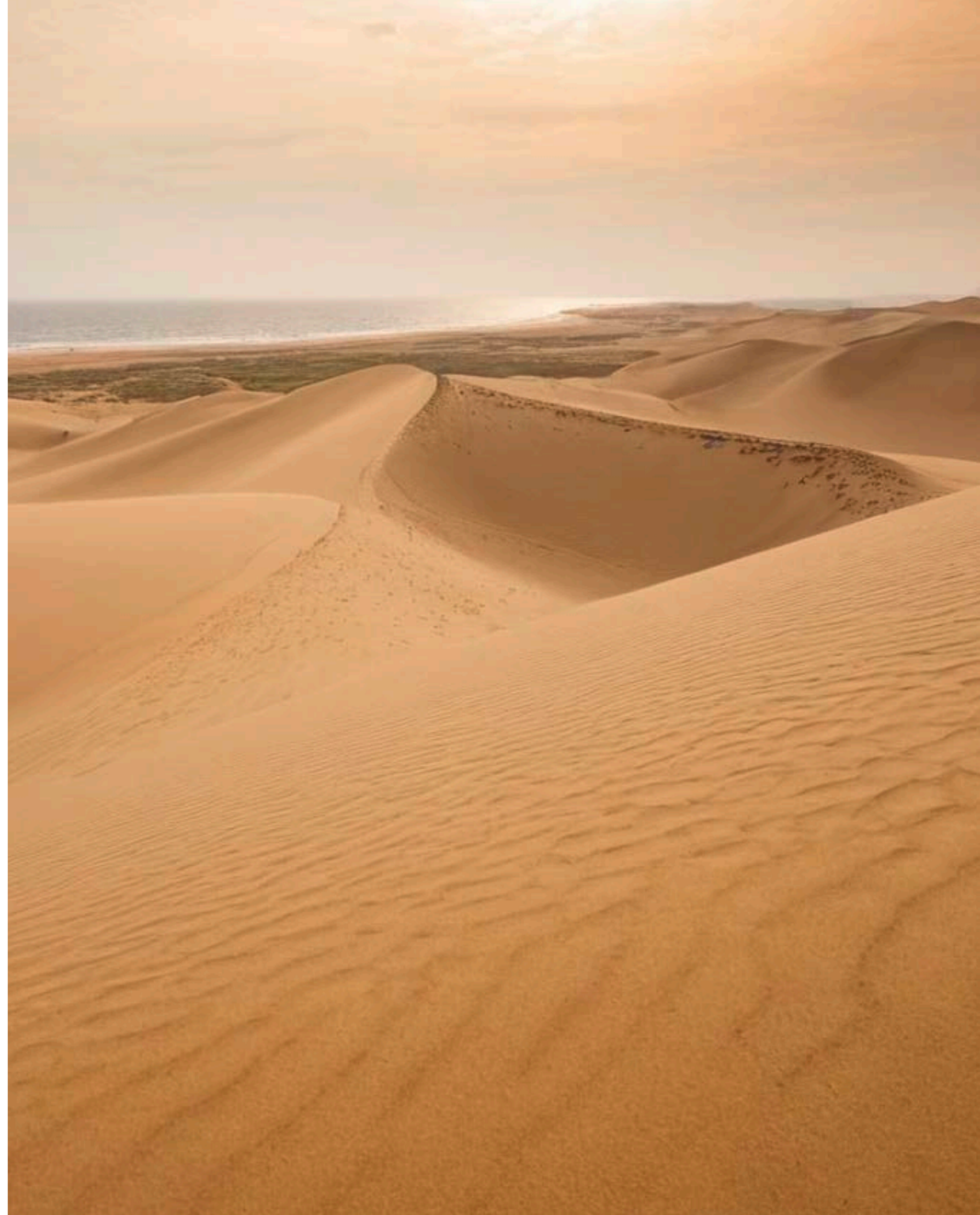



Living Dune 03





**P**erfect fluidity.  
A generous surface highlights the wood grain and depth of the stone, harmonising texture and proportion with natural elegance.

**D**inamica perfetta.  
Un'ampia superficie che esalta le venature del legno e la profondità della pietra, armonizzando matericità e proporzioni con naturale eleganza.

**B**alance and solidity.  
The base, in a lacquered or leather finish, contrasts beautifully with the shine of metal, creating a sophisticated interplay of textures and reflections.

**E**quilibrio e solidità.  
Il fusto, laccato o rivestito in pelle, dialoga con la lucentezza del metallo, creando un contrasto sofisticato tra texture e riflessi.



**G**ea  
round table  
tavolo tondo



**G**ea  
round table  
*tavolo tondo*





**Geometry and simplicity.**

The combination of wood, metal and leather creates a refined balance, where precious details define a unique style for highly customisable interiors.

**Geometria ed essenzialità.**

L'incontro tra legno, metallo e pelle crea un equilibrio raffinato, dove dettagli preziosi definiscono uno stile unico per ambienti altamente personalizzabili.



**G**ea  
table  
tavolo



**S**culptural lightness.  
Flowing lines and well-proportioned volumes shape a seat with bold character. A perfect balance of style and comfort, designed to elegantly embrace.

**L**eggerezza scultorea.  
Linee sinuose e volumi ben calibrati definiscono una seduta dal carattere deciso. Un equilibrio perfetto tra estetica e comfort, pensato per avvolgere con eleganza.



**Y**uma  
chair  
*sedia*



**G**lamis  
sideboard  
*madia*



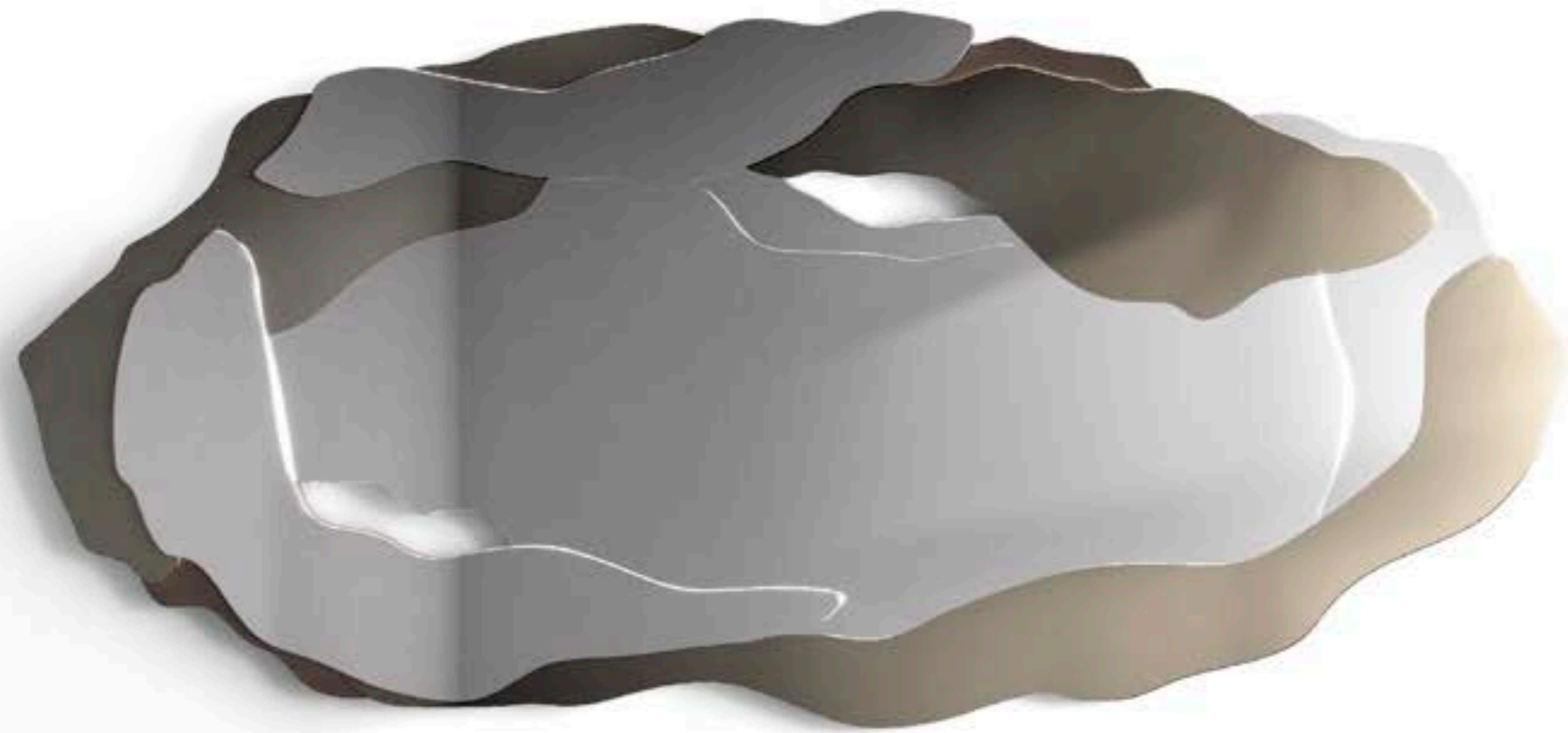

**Sculpted reflections.**  
A play of depth and light  
takes shape in layered panels  
of natural and bronze-tinted  
mirror.  
Irregular profiles and shifting  
tones create a material illusion  
in constant motion.

**Riflessioni scolpite.**  
Un gioco di profondità e  
luce prende forma in strati  
sovrapposti di specchio  
naturale e bronzato.  
Profili irregolari e sfumature  
cangianti creano un'illusione  
materica in continuo  
movimento.

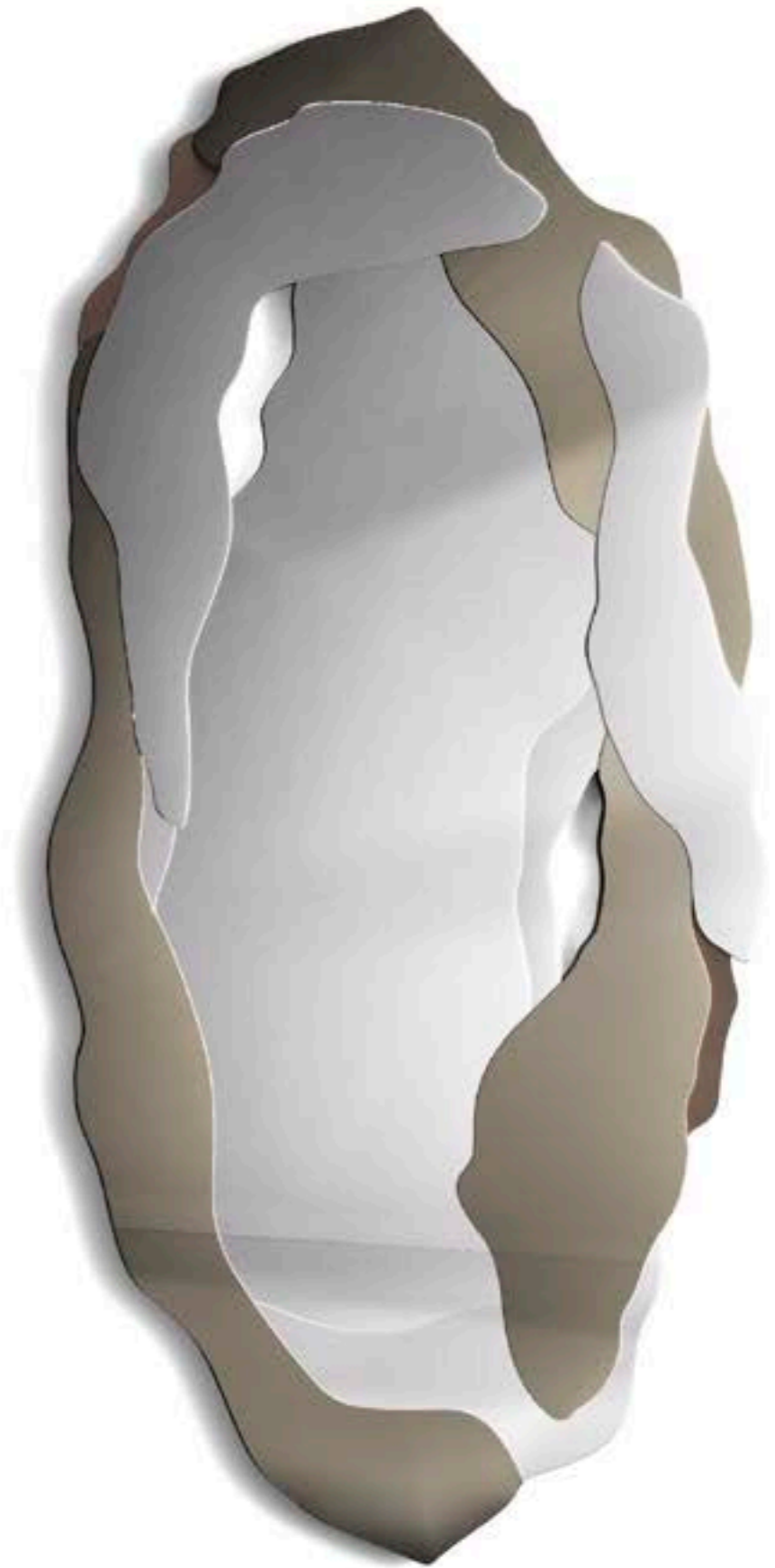

**T**ara  
mirror  
*specchio*



n ight area Dune 04

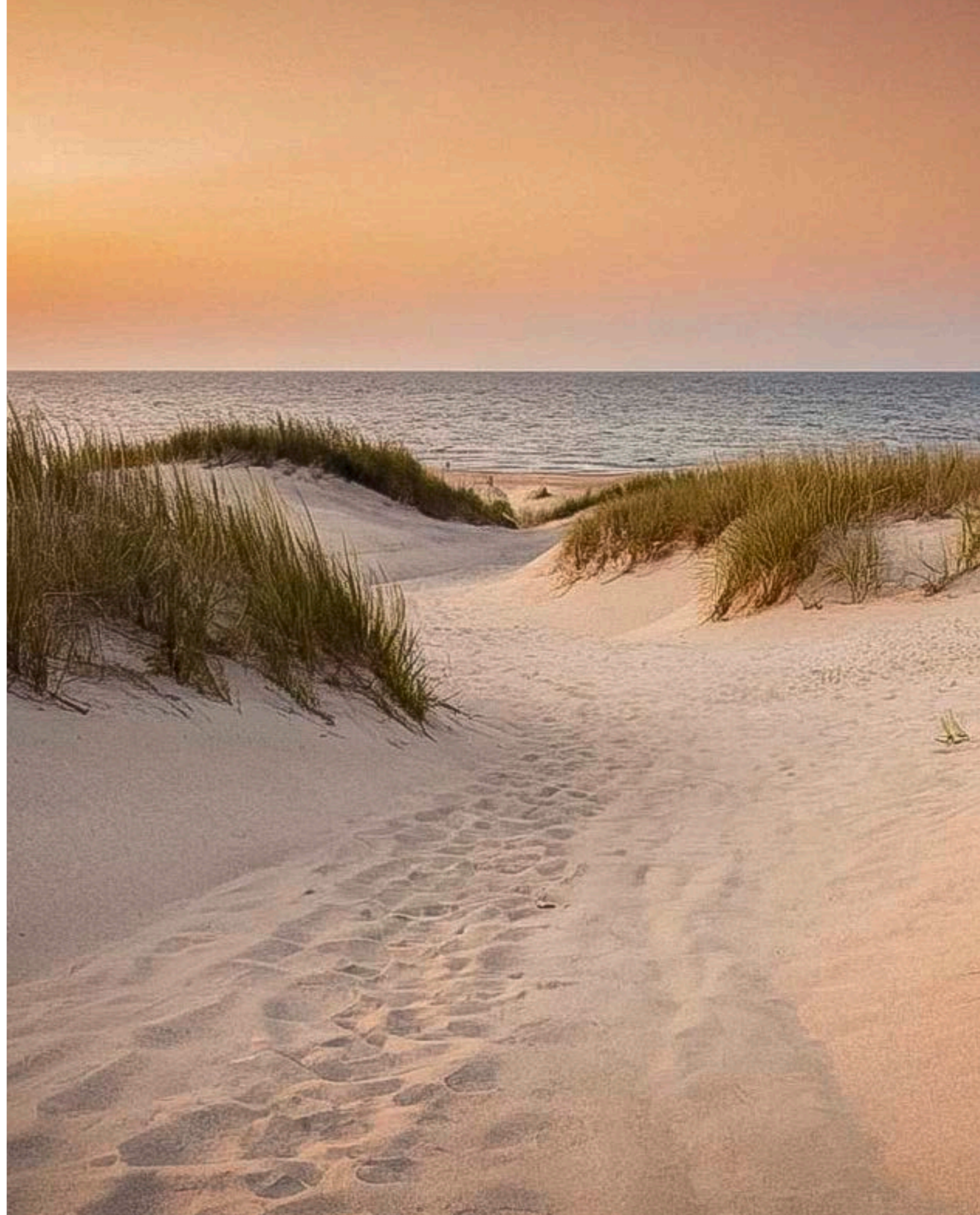





Soft, welcoming forms suggest an intimate and sophisticated atmosphere. The warmth of wood blends with precious details, while the drawer, with its smooth and silent glide, adds a discreet touch of elegance.

Forme morbide e accoglienti suggeriscono un'atmosfera intima e sofisticata. Il calore del legno si unisce a dettagli preziosi, mentre il cassetto, con un'apertura fluida e silenziosa, aggiunge un tocco di discreta eleganza.

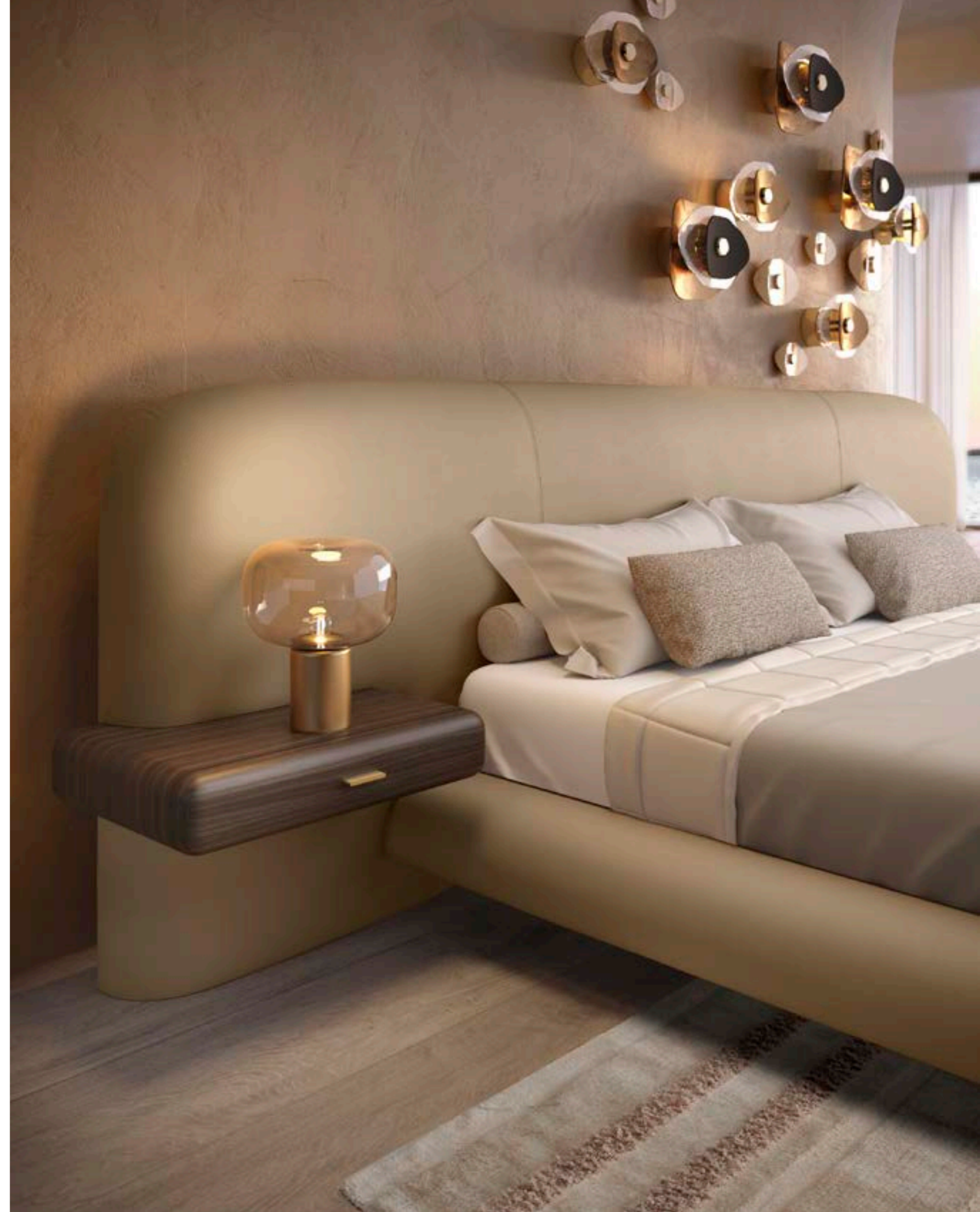



**D**une  
bed  
*letto*



**A** material embrace inspired by the earth. The rounded headboard evokes the gentle curves of natural forms, offering elegance and comfort. A balance of soft and solid volumes conveys a sense of primal harmony.

**U**n abbraccio materico ispirato alla terra.

La testiera arrotondata evoca la dolcezza delle forme naturali, accogliendo con eleganza e comfort. Un equilibrio di linee morbide e solide che trasmette una sensazione di armonia primordiale.



**G**ea  
bed  
letto

**G**lamis  
big vanity table  
*toilette consolle grande*





Comfortable elegance.

Generous volumes define a relaxing haven, where every detail expresses balance and refinement.

The side table insert adds a touch of sophisticated practicality, naturally blending style and functionality.

Confortevole eleganza.

Volumi generosi definiscono un'isola di relax, dove ogni dettaglio esprime equilibrio e raffinatezza.

L'insero laterale del tavolino aggiunge un tocco di sofisticata praticità, fondendo estetica e funzionalità con naturale armonia.



**D**une  
sofa  
*divano*



**Arenaria**  
carpet  
*tappeto*

**H**armonious volumes are expressed through two distinct visions: the lacquered chest of drawers enhances the purity of form, while the bedside table, enriched with marble and leather, plays with refined material contrasts. Two interpretations of elegance, united by a carefully considered design language.

**V**olumi armoniosi si esprimono in due visioni distintive: il comò laccato valorizza la purezza delle forme, mentre il comodino, arricchito da marmo e pelle, gioca con contrasti materici raffinati. Due interpretazioni di eleganza, unite da un'estetica ricercata.



**G**lamis  
6 drawers dresser and night table  
comò 6 cassetti e comodino

forest villa





## Living Forest 05

Soft lines and enveloping modularity. A sofa designed to redefine spaces with balance and versatility, offering tailor-made comfort.

Linee morbide e modularità avvolgente. Un divano pensato per ridefinire gli spazi con equilibrio e versatilità, offrendo un comfort su misura.





**F**orest  
sofa  
*divano*



**F**orest  
sofa  
*divano*

**A** sofa that conveys both poise and lightness, with a refined base that highlights its silhouette. The absence of armrests amplifies the sense of openness and fluidity, transforming the piece into an invitation for total relaxation.

**U**n divano che esprime equilibrio e leggerezza, con una base raffinata che ne esalta la silhouette. L'assenza di appoggi laterali amplifica la sensazione di apertura e fluidità, trasformandolo in un invito al relax senza confini.





**F**orest  
armchair  
*poltrona*

**C**analetto walnut and glass merge in a play of light and reflection. Solid bases in natural stone anchor the structure, creating a refined balance between solid and void. A mirrored base and LED lighting highlight every detail with an added touch of light and depth.



**N**oce canaletto e vetro si fondono in un gioco di luci e riflessi. Solide basi in pietra naturale ancorano la struttura, creando un raffinato equilibrio tra vuoti e pieni. Il fondo a specchio e l'illuminazione LED valorizzano ogni dettaglio con un tocco di luminosità e profondità.



**D**une  
low cabinet  
*mobile basso*





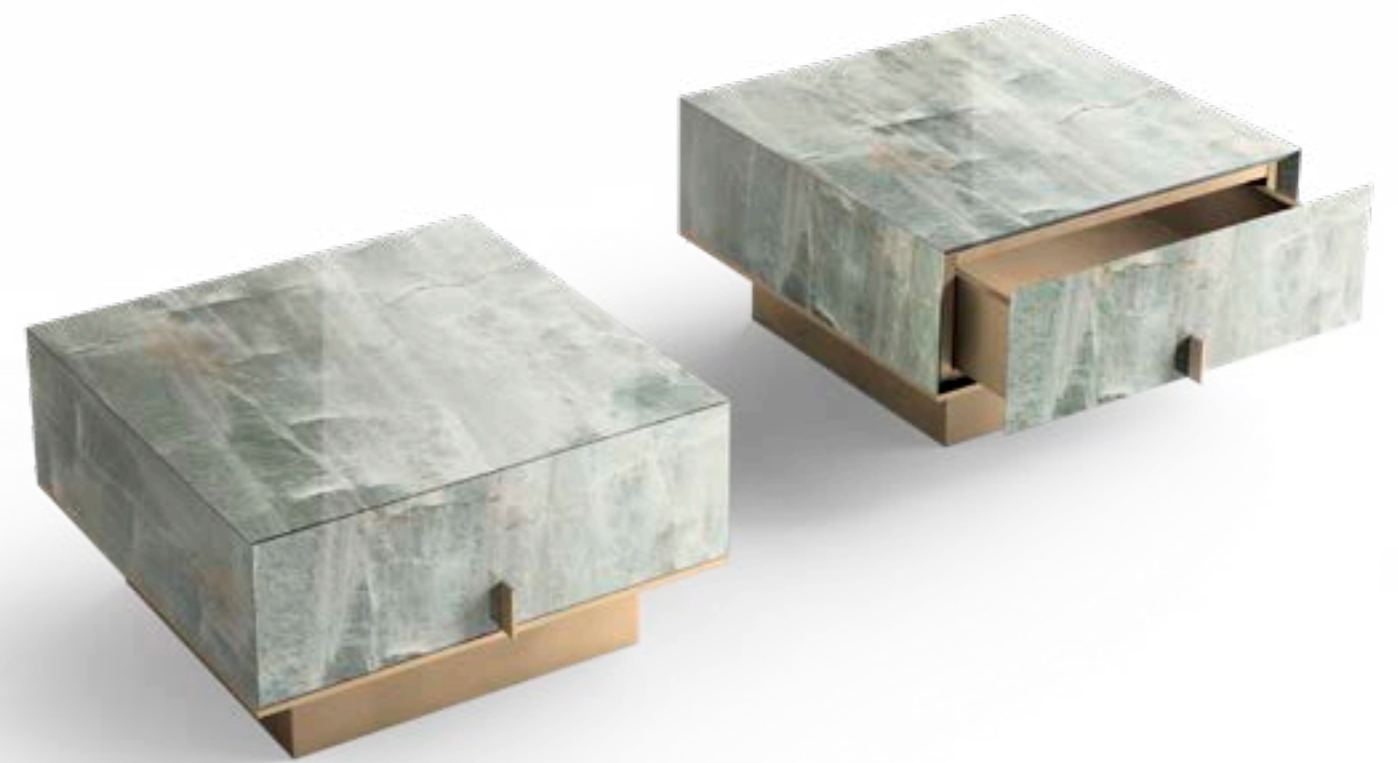

**S**unda  
side table  
*tavolino*



**A** compact, precious volume, suspended on an elegant base that celebrates its lightness. The surface, rich in natural tones, wraps around the entire structure, creating a monolithic effect with a strong visual impact.

**U**n volume compatto e prezioso, sospeso su una base elegante che ne esalta la leggerezza. La superficie, ricca di sfumature naturali, avvolge l'intera struttura, creando un effetto monolitico di grande impatto visivo.



**G**lamis  
low cabinet  
*mobile basso*

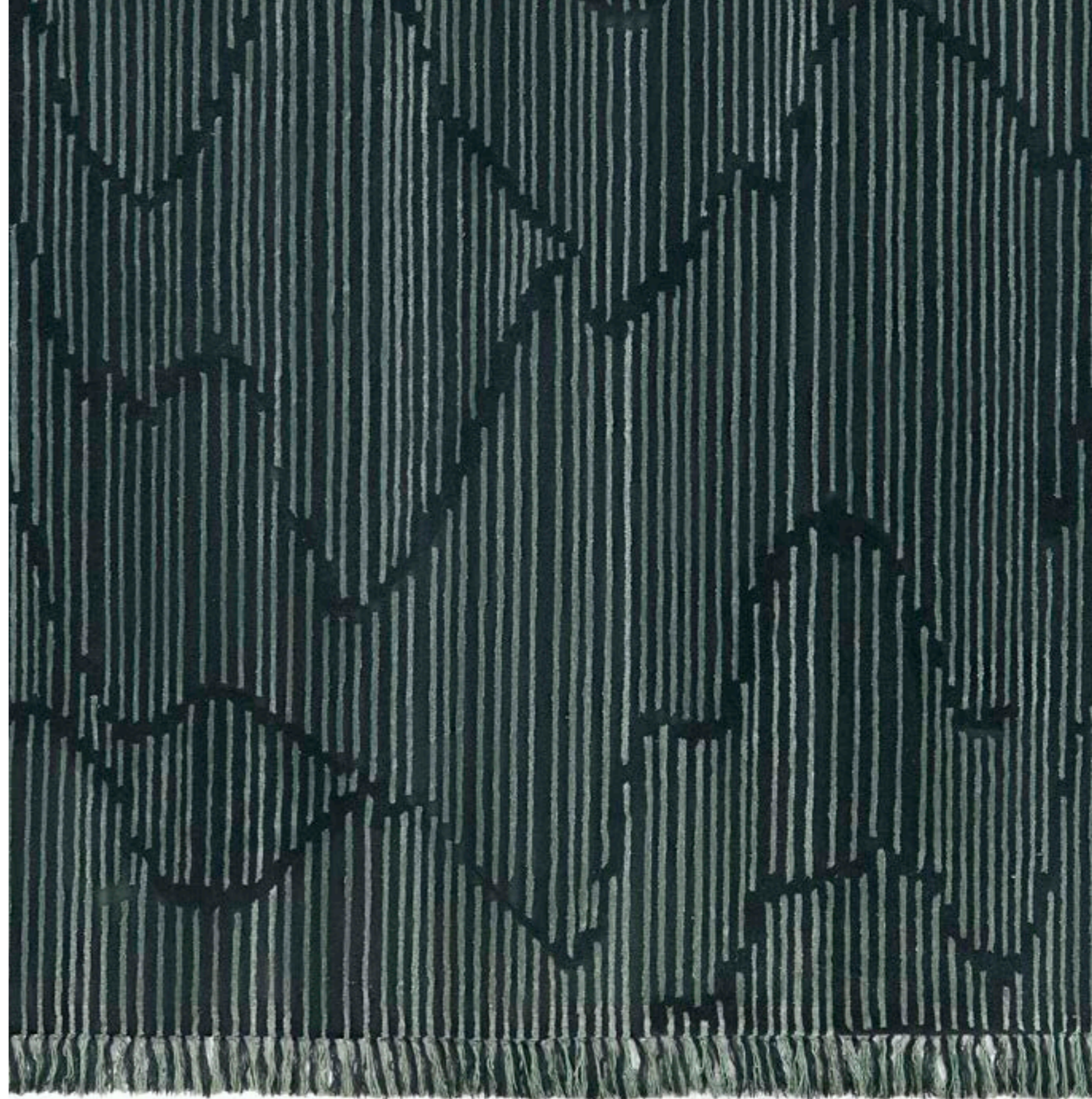

**R**ain forest  
carpet  
*tappeto*

## dining area

**T**he dining area is dressed in warm, textured tones, where wood interacts with natural stone.

Understated forms and refined details define a space of genuine elegance.

**L**a dining area si veste di tonalità calde e materiche, dove il legno dialoga con la pietra naturale.

Forme essenziali e dettagli raffinati definiscono uno spazio di autentica eleganza.

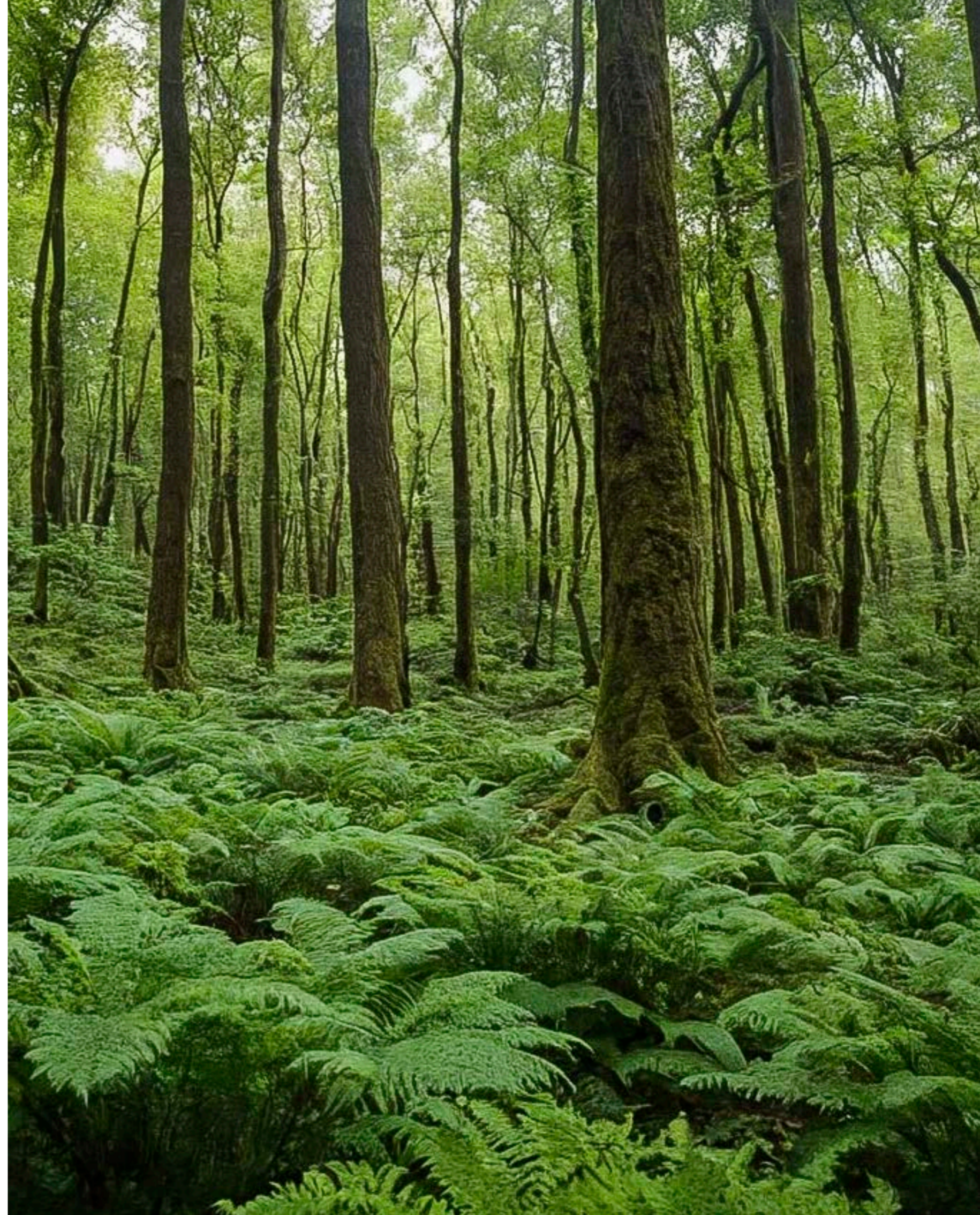





The tabletop, in wood or marble, rests on sculptural natural stone bases, bringing the strength and elegance of primal elements into the home.  
A harmonious meeting of design and nature.



Il piano, in legno o marmo, si appoggia su basi scultoree in pietra naturale, portando in casa la forza e l'eleganza degli elementi primordiali. Un incontro armonico tra design e natura.



Tara  
table  
tavolo





Living Forest 06





Tara  
sideboard  
*madia*



**C**lean lines and a sculptural inlay give life to a refined interplay of shades inspired by nature. Every detail is the result of precise craftsmanship, where skilled hands combine fine woods to create a unique textural effect. The metal base enhances the design, while subtle lighting adds warmth and depth.

**L**inee essenziali e un intarsio dal fascino scultoreo danno vita a un raffinato gioco di sfumature ispirato alla natura. Ogni dettaglio è frutto di un'accurata lavorazione artigianale, dove mani esperte combinano legni pregiati per creare un effetto materico unico. La base in metallo ne valorizza il design, mentre l'illuminazione discreta aggiunge profondità e calore.





**A** composition defined by precise joinery, where a cut into the stone cradles the transparent top in perfect harmony, creating balance between strength and lightness, solid and void.



**U**n incontro definito da un preciso incastro, dove il taglio nella roccia accoglie il ripiano trasparente con armonia, creando un equilibrio perfetto tra forza e leggerezza, vuoti e pieni.



**D**une  
glass cabinet  
*vetrina*



**F**orest  
glass cabinet  
*vetrina*

**A** seat that combines the warmth of solid wood with the softness of upholstery. Clean, lightweight lines define a welcoming, agile structure where form and comfort blend with natural elegance.



**U**na seduta che unisce il calore del legno massello alla morbidezza del rivestimento. Linee essenziali e leggere definiscono una struttura accogliente e agile, in cui forma e comfort si fondono con naturale eleganza.



**T**ara  
chair  
*sedia*



## n i g h t a r e a

**A** tribute to the beauty of nature, transformed into an exclusive and sophisticated design. Delicate atmospheres, soft lighting and enveloping materials shape an intimate space where every element contributes to a timeless elegance.

**U**n omaggio alla bellezza della natura trasformata in un design esclusivo e sofisticato. Atmosfere rarefatte, luce morbida e materiali avvolgenti disegnano uno spazio intimo, dove ogni elemento contribuisce a un'eleganza senza tempo.





n i g h t a r e a F o r e s t 0 7



**N** a m i b i a  
b e d  
*l e t t o*

## Letto Namibia

The curved headboard with open compartments in Canaletto walnut brings together style and functionality, offering practical integrated storage. Subtle LED lighting enhances the intimate and refined atmosphere.

La testata curva con vani a giorno in noce canaletto unisce estetica e funzionalità, offrendo pratici spazi integrati. L'illuminazione LED discreta accentua l'atmosfera intima e sofisticata.



**U**nderstated and refined, the Vanity Console with a wood or natural stone top includes a seamlessly integrated drawer.

The mirror emits a soft, diffused light, creating the ideal setting for a daily beauty ritual.

**E**ssenziale e raffinata, la Consolle con top in legno o pietra naturale accoglie un cassetto perfettamente integrato. Lo specchio diffonde una luce avvolgente, creando l'atmosfera ideale per un rituale di bellezza quotidiano.





**G**lamis  
Vanity console  
*toilette consolle*



**E**legant surfaces and balanced proportions define this chest of drawers, where soft-touch finishes meet structural solidity. The top enhances the composition, while every detail conveys discreet and harmonious elegance.



**S**uperfici eleganti e proporzioni equilibrate definiscono questa cassetiera, un incontro tra soft touch e solidità. Il top valorizza la composizione, mentre ogni dettaglio esprime un'eleganza discreta e armoniosa.



**G**lamis  
3 drawer dresser  
*comò 3 cassetti*



**S**ahara  
armchair  
*poltrona*





**F**lowing forms and enveloping reflections inspired by the beauty of agate.

The natural and bronze-tinted mirror evokes the depth of stone, while the frame, either lacquered or upholstered in leather and velvet, highlights the interplay between matter and light.



**F**orme fluide e riflessi avvolgenti ispirati alla bellezza dell'agata. Lo specchio naturale e bronzato richiama le profondità della pietra, mentre la cornice, laccata o rivestita in pelle e velluto, esalta il dialogo tra materia e luce.



**A**gata  
mirror  
*specchio*



Technical data

# Technical data

## Wood types - *Essenze*



DARK WALNUT  
NOCE SCURO

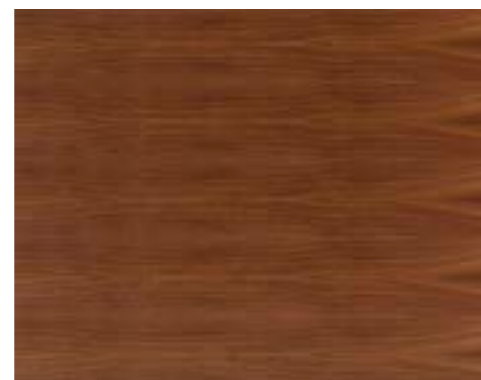

LIGHT WALNUT  
NOCE CHIARO

## Laccati - *Essenze*



DOVE-GREY FINISH  
FINITURA LACCATO TORTORA



IVORY FINISH  
FINITURA LACCATO AVORIO

## Metals - *Metalli*



BRUSHED GOLD  
ORO SPAZZOLATO

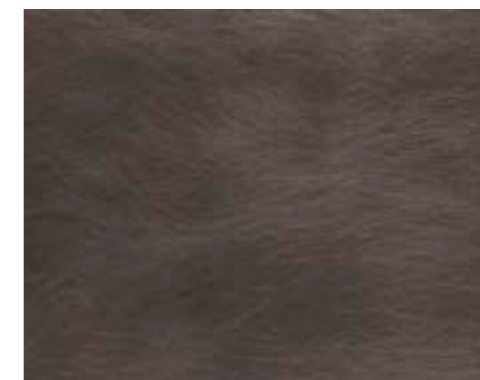

BRUSHED BRONZE  
BRONZO SPAZZOLATO



BRUSHED BIOTITE  
BIOTITE SPAZZOLATO

## Marble types - *Marmi*



TRAVERTINO SILVER  
MANO LEATHER  
TRAVERTINE SILVER  
MANO LEATHER



ACQUA-QUARZITE  
ACQUA-QUARZITE

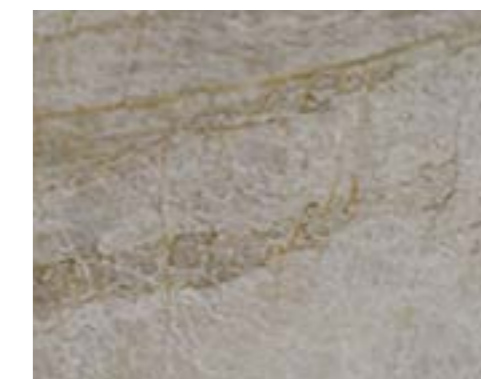

TAJ MAHAL  
TAJ MAHAL



ONYX  
(FOR WALL LAMP FOREST ONLY)  
ONICE  
(SOLO PER LAMPADA A MURO FOREST)

# Technical data

## dining room elements | mobili sala

sofa Dune  
Divano Dune



**STRUCTURE:** plywood.  
**PADDING:** differentiated density polyurethane foam.  
**UPHOLSTERY:** a choice of fabric or leather.  
**TABLE:** wood canaletto walnut with light or dark matt finish; or with top in: marble Travertine Silver, or quartz Taj Mahal or Acqua-quarzite.

**STRUTTURA:** multistrato espanso a densità differenziata.  
**IMBOTTITURA:** poliuretano a densità differenziata.  
**RIVESTIMENTO:** pelle o tessuto a scelta.  
**TAVOLINO:** in legno noce canaletto con finitura chiaro o scuro opaco; o con top in: marmo Travertino Silver; quarzo Taj Mahal o Acqua-quarzite.

SOFA COMPOSITION 1 DUNE  
COMPOSIZIONE DEL DIVANO 1 DUNE

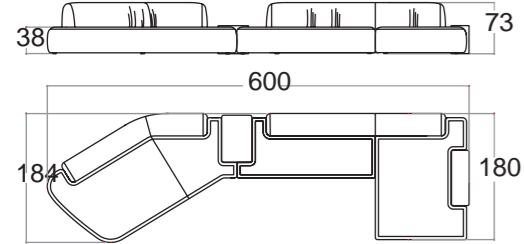

SOFA COMPOSITION 2 DUNE  
DIVANO COMPOSIZIONE 2 DUNE

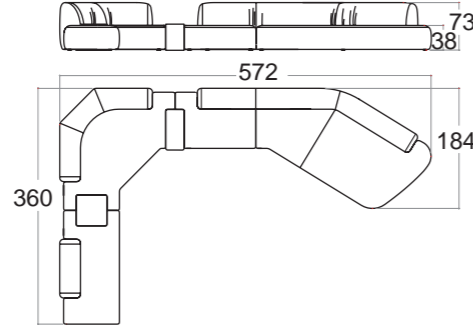

ELEMENT 2S /END ELEMENT RH DUNE SMALL TABLE  
2 POSTI CENTRALE/FINALE DX SX CON TAVOLINO

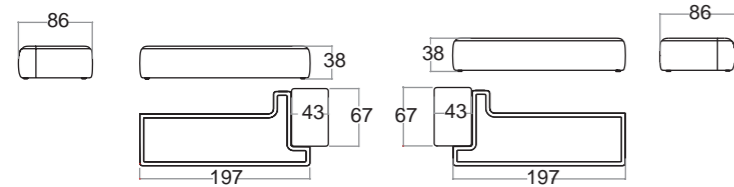

END ELEMENT DUNE RH - LH  
FINALE DX SX CON TAVOLINI

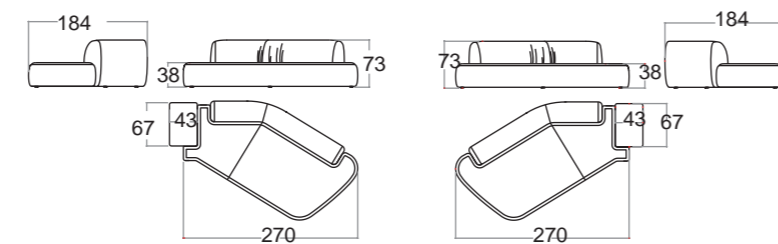

END ELEMENT RH - LH  
FINALE DX SX

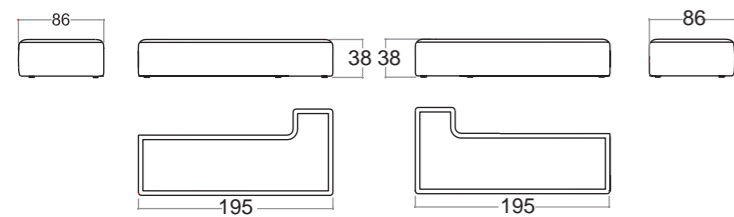

ELEMENT CHAISE LONGUE RH DUNE SMALL TABLE  
CHAISE LONGUE DX SX CON TAVOLINO

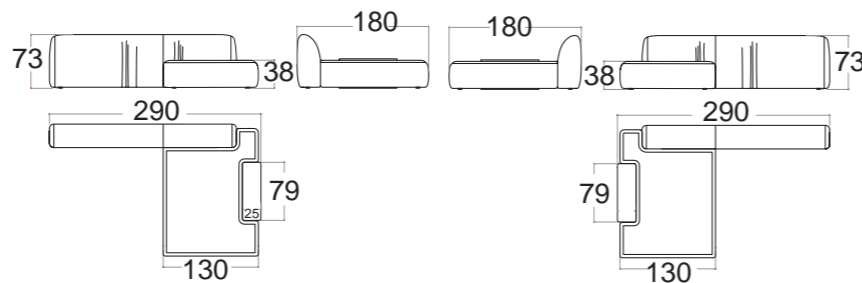

CHAISE LONGUE ELEMENT RH - LH  
CHAISE LONGUE DX SX

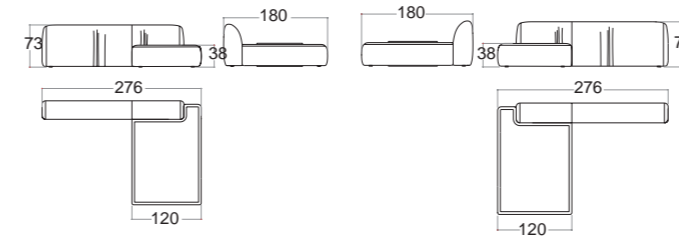

CORNER ELEMENT RH - LH  
ANGOLARE DX SX

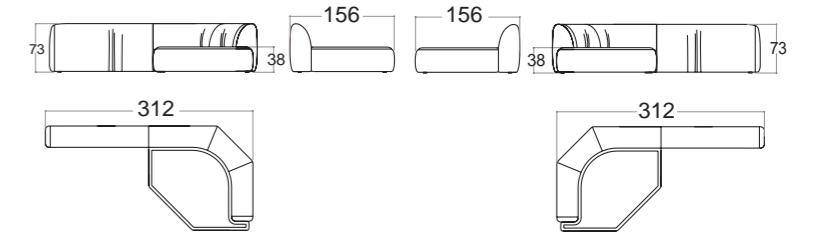

2 SEATERS SOFA DUNE WITH TABLE  
2 POSTI CON TAVOLINO

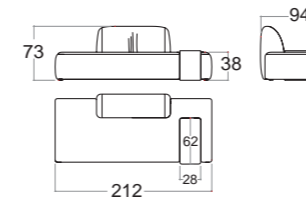

ISLAND DUNE WITH 2 TABLES  
ISOLA CON 2 TAVOLINI

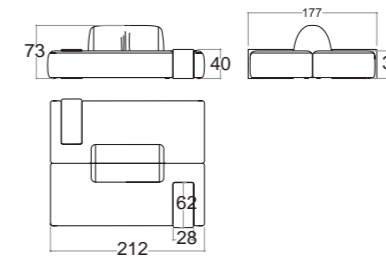

CORNER TABLE RH - LH  
ANGOLARE DX SX CON TAVOLINI

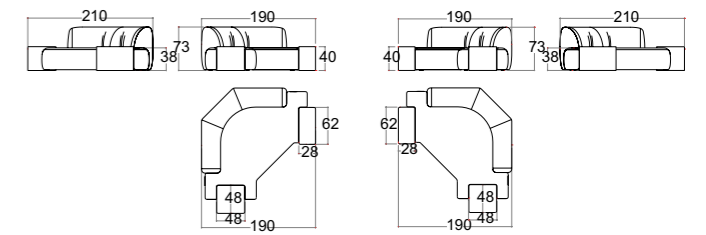

END ELEMENT WITH RIGHT TABLE DUNE  
ELEMENTO FINALE DESTRO CON TAVOLO

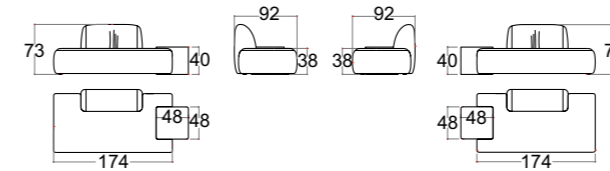

END INCLINED ELEMENT RH - LH  
FINALE INCLINATO DX SX CON TAVOLINO

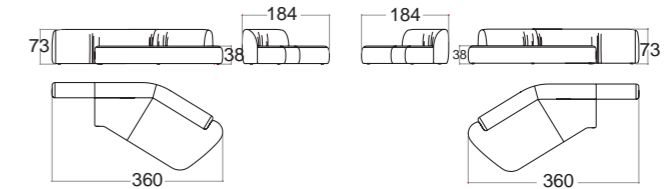

1 SEATER CENTRAL ELEMENT RH - LH  
CENTRALE 1 POSTO DX SX CON TAVOLINO

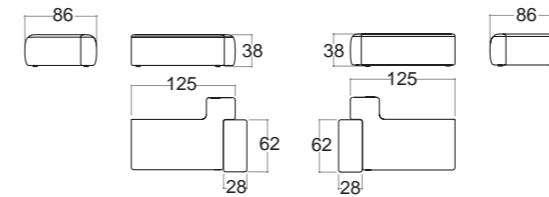

BACK SMALL TABLE "A"  
TAVOLINO POSTERIORE A

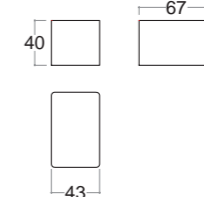

CHAISE LONGUE SMALL TABLE "B"  
TAVOLINO CHAISE LONGUE B

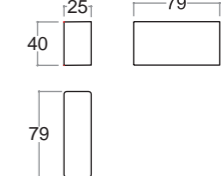

CORNER/ISLAND SMALL TABLE "C"  
TAVOLINO ANGOLO ISOLA C

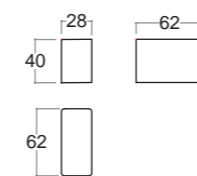

TAVOLINO FINALE/ANGOLO "D"  
END/CORNER SMALL TABLE "D"

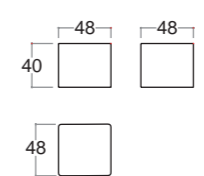

sofa Forest  
divano Forest



**STRUCTURE:** plywood.  
**FEET:** metal available in the three finishes brushed Biotite, Brushed Gold, Brushed Bronze.  
**PADDING:** differentiated density polyurethane foam.  
**UPHOLSTERY:** a choice of fabric or leather.

**STRUTTURA:** multistrato  
**PIEDI:** metallo disponibile nelle tre finiture Biotite spazzolato, Oro spazzolato e Bronzo spazzolato.  
**IMBOTTITURA:** poliuretano espanso a densità differenziata.  
**RIVESTIMENTO:** pelle o tessuto a scelta.

SIDE ELEMENT RH - LH WITHOUT ARM  
FINALE INCLINATO DX-SX SENZA BRACCIOLO

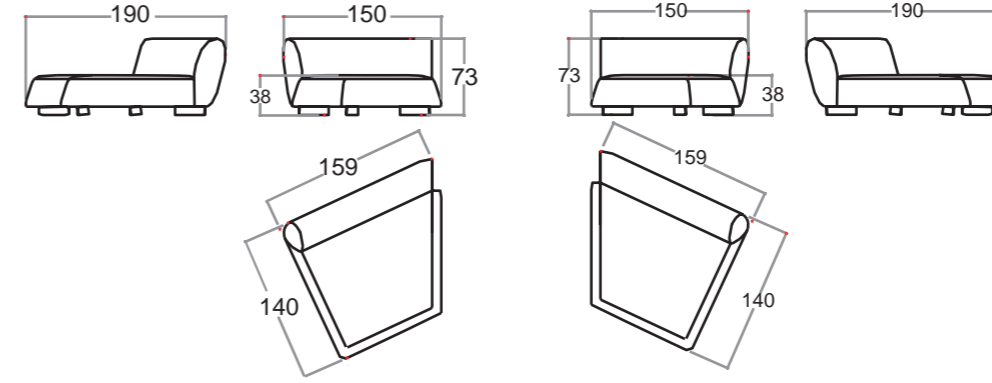

CENTRAL ELEMENT  
ELEMENTO CENTRALE

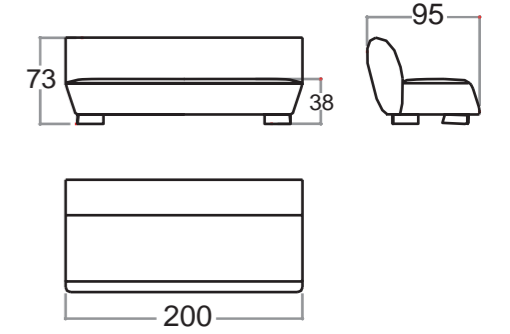

SOFA COMPOSITION 1  
COMPOSIZIONE DEL DIVANO 1

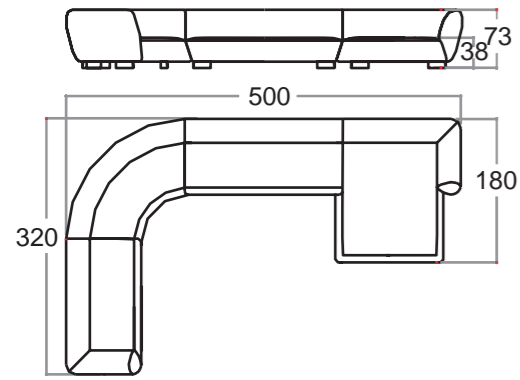

SOFA COMPOSITION 2  
COMPOSIZIONE DEL DIVANO 2

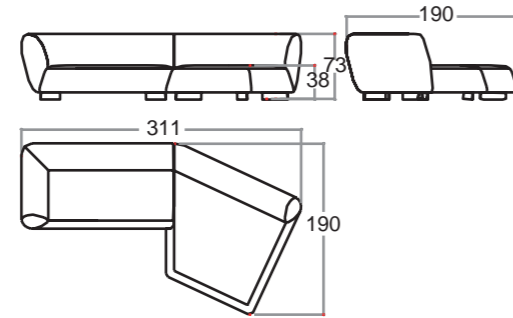

END ELEMENT WITH RH - LH ARM  
FINALE INCLINATO DX-SX CON BRACCIOLO

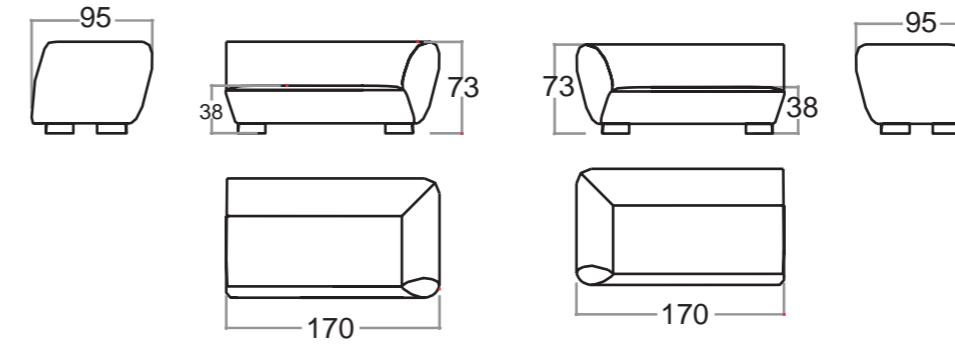

CORNER ELEMENT  
ANGOLARE

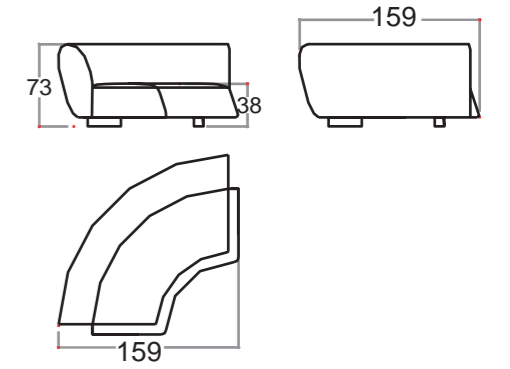

SOFA 2 SEATER WITHOUT ARMREST  
DIVANO 2 POSTI SENZA BRACCIOLI

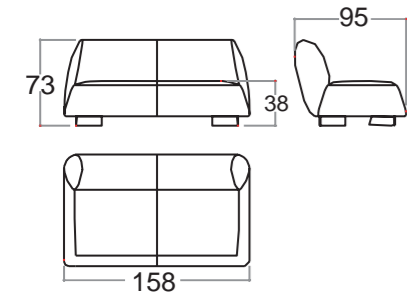

SOFA 3 SEATER WITHOUT ARMREST  
DIVANO 3 POSTI SENZA BRACCIOLI

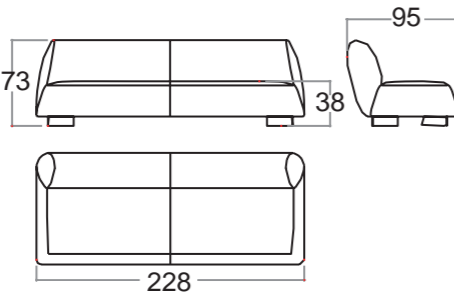

SOFA 4 SEATER WITHOUT ARMREST  
DIVANO 4 POSTI SENZA BRACCIOLI

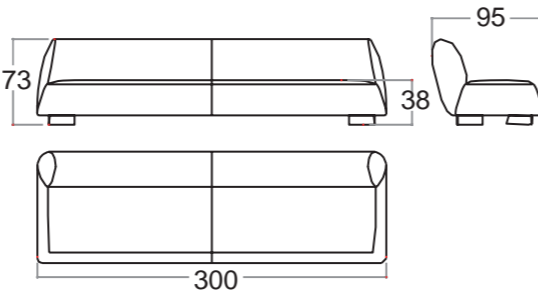

CHAISE LONGUE RH - LH  
CHAISE LONGUE DX SX

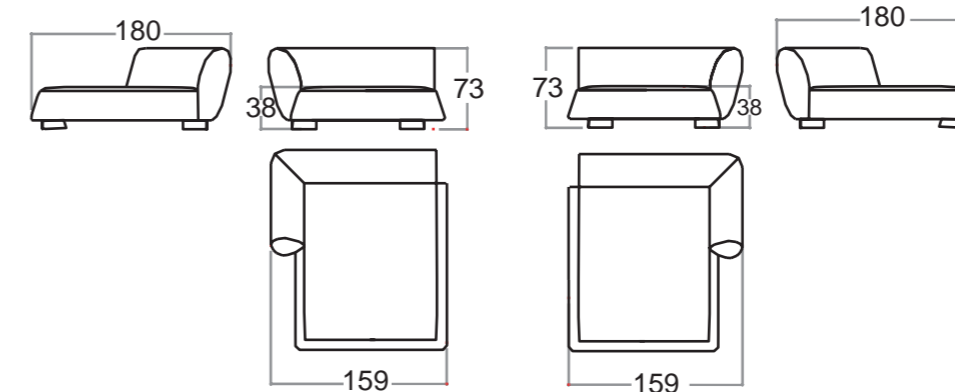

SOFA 2 SEATER WITH ARMREST  
DIVANO 2 POSTI CON BRACCIOLI

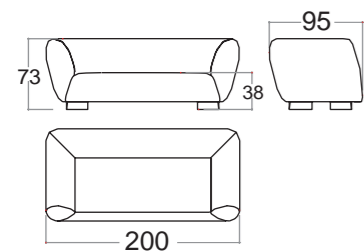

SOFA 3 SEATER WITH ARMREST  
DIVANO 3 POSTI CON BRACCIOLI

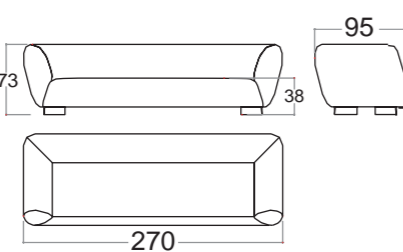

SOFA 4 SEATER WITH ARMREST  
DIVANO 4 POSTI CON BRACCIOLI

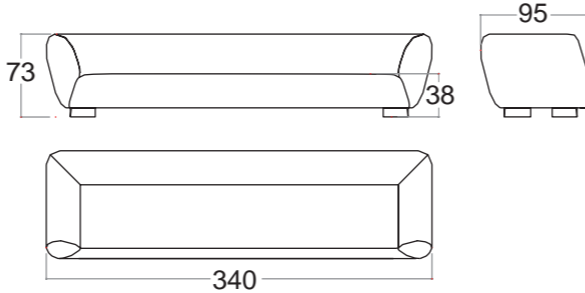

sofa Glamis  
divano Glamis



SOFA GLAMIS  
DIVANO GLAMIS

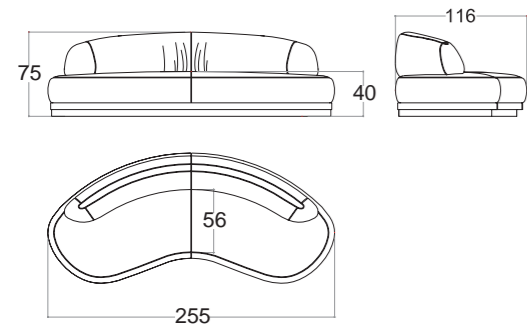

SOFA WITH SMALL TABLE  
DIVANO CON TAVOLINO GLAMIS

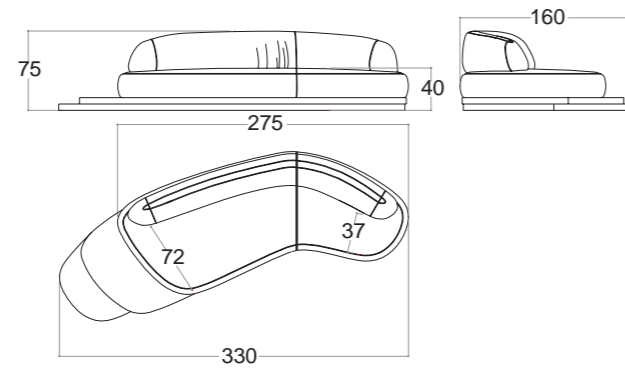

**STRUCTURE:** plywood.  
**BASES:** double base with canaletto walnut wood with light or dark matt finish for top base, and bottom base with metal finish available in three finishes brushed Biotite, Brushed Gold, Brushed Bronze.  
**PADDING:** differentiated density polyurethane foam.  
**UPHOLSTERY:** a choice of fabric or leather.

**STRUTTURA:** multistrato  
**BASI:** doppio basamento in legno noce canaletto con finitura chiaro o scuro opaco per base superiore, per base inferiore finitura metallo disponibile nelle tre finiture Biotite spazzolato, Oro spazzolato e Bronzo spazzolato.  
**IMBOTTITURA:** poliuretano espanso a densità differenziata  
**RIVESTIMENTO:** pelle o tessuto a scelta

little armchair Tottori  
poltroncina Tottori

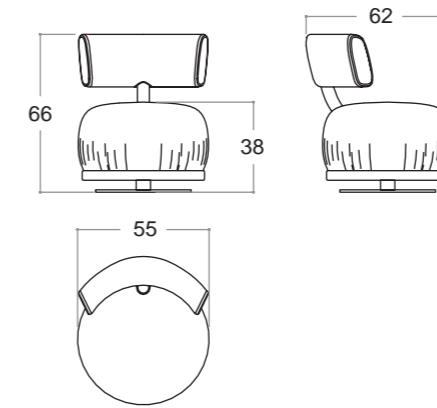

**FRAME:** metal with three finishes: Brushed Biotite, Brushed Gold and Brushed Bronze.  
**SEATS AND BACKS:** polyurethane foam.  
**UPHOLSTERY:** a choice of fabric or leather.

**STRUTTURA:** metallo in tre finiture: Biotite spazzolato, Oro spazzolato e Bronzo spazzolato  
**SEDUTE E SCHIENALI:** poliuretano espanso.  
**RIVESTIMENTO:** pelle o tessuto a scelta.

armchair Forest  
poltrona Forest

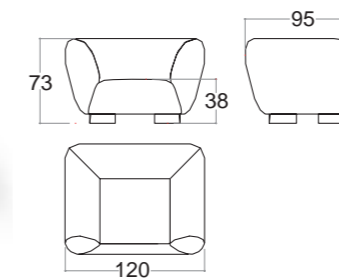

**STRUCTURE:** plywood.  
**FEET:** metal available in the three finishes brushed Biotite, Brushed Gold, Brushed Bronze.  
**PADDING:** differentiated density polyurethane foam.  
**UPHOLSTERY:** a choice of fabric or leather.

**STRUTTURA:** multistrato  
**PIEDI:** metallo disponibile nelle tre finiture Biotite spazzolato, Oro spazzolato e Bronzo spazzolato.  
**IMBOTTITURA:** poliuretano espanso a densità differenziata.  
**RIVESTIMENTO:** pelle o tessuto a scelta.

armchair Dune  
poltrona Dune

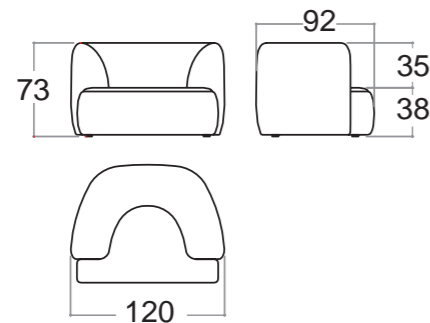

**STRUCTURE:** plywood.  
**PADDING:** differentiated density polyurethane foam.  
**UPHOLSTERY:** a choice of fabric or leather.

**STRUTTURA:** multistrato  
**IMBOTTITURA:** poliuretano espanso a densità differenziata.  
**RIVESTIMENTO:** pelle o tessuto a scelta.

armchair Forest without armrest  
poltrona Forest senza braccioli

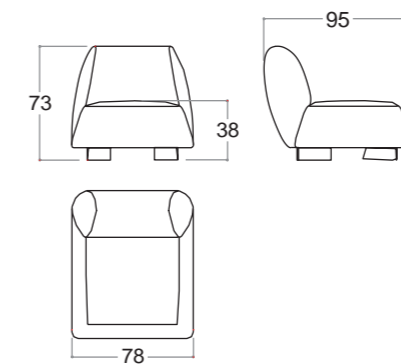

**STRUCTURE:** plywood.  
**FEET:** metal available in the three finishes brushed Biotite, Brushed Gold, Brushed Bronze.  
**PADDING:** differentiated density polyurethane foam.  
**UPHOLSTERY:** a choice of fabric or leather.

**PIEDI:** metallo disponibile nelle tre finiture Biotite spazzolato, Oro spazzolato e Bronzo spazzolato.  
**IMBOTTITURA:** poliuretano espanso a densità differenziata.  
**RIVESTIMENTO:** pelle o tessuto a scelta.

armchair Sahara  
poltrona Sahara

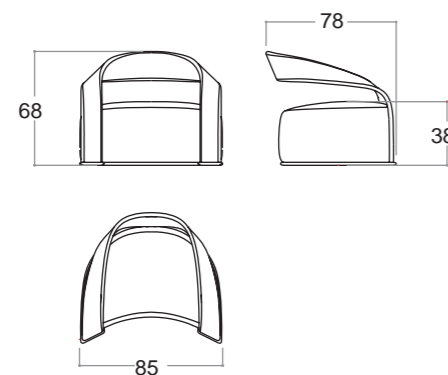

**FRAME:** metal with three finishes: Brushed Biotite, Brushed Gold and Brushed Bronze.  
**SEATS:** polyurethane foam.  
**UPHOLSTERY:** a choice of fabric or leather  
**BACKSEAT:** upholstered with leather of your Choice

**STRUTTURA:** metallo in tre finiture: Biotite spazzolato, Oro spazzolato e Bronzo spazzolato  
**SEDUTA:** poliuretano espanso.  
**RIVESTIMENTO:** pelle o tessuto a scelta.  
**SCHIENALE:** rivestito con pelle a scelta

pillows  
cuscini

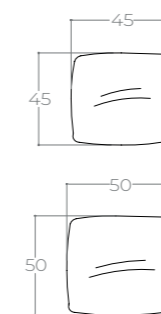

**UPHOLSTERY:** with fabric or leather of your choice

**PADDING:** polyurethane foam

coffee table Dune  
tavolino Dune



**TOP:** choice between marble Travertino Silver Mano Leather or quartz Taj Mahal and Acqua-quarzite.  
**METAL BASE:** available with three finishes: Brushed Biotite, Brushed Gold and Brushed Bronze.

**TOP:** in marmo Travertino Silver Mano Leather o quarzite Taj Mahal e Acqua-quarzite.  
**BASE METALLO:** disponibile in tre finiture: Biotite spazzolato, Oro spazzolato e Bronzo spazzolato.

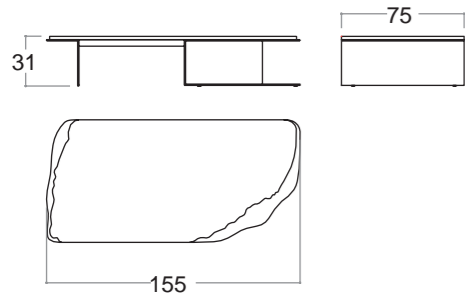

RECTANGULAR COFFEE TABLE 155x75  
TAVOLINO RETTANGOLARE 155x75

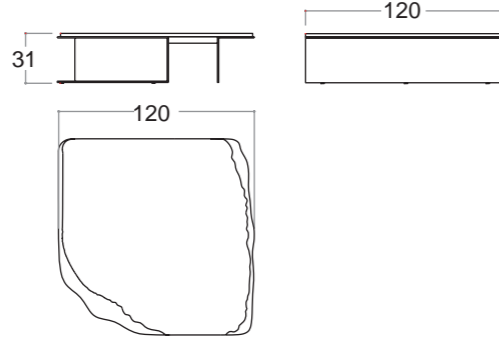

SQUARE COFFEE TABLE 120  
TAVOLINO QUADRATO 120

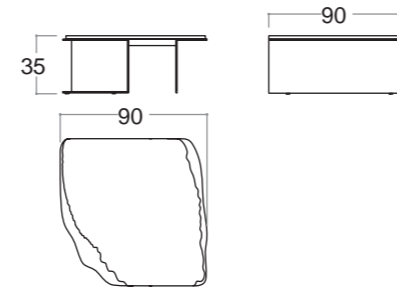

SQUARE COFFEE TABLE 90  
TAVOLINO QUADRATO 90

central table Glamis  
tavolino centrale Glamis

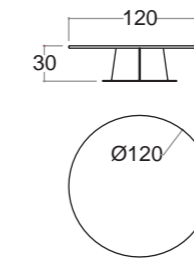
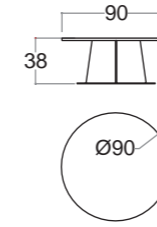

**TOP:** possible with Canaletto walnut wood dark or light matt finish; lacquered wood; or choice between marble Travertino Silver Mano Leather or quartz Taj Mahal and Acqua-quarzite.  
**METAL BASE:** available with three finishes: Brushed Biotite, Brushed Gold and Brushed Bronze.  
**STEM:** possible with lacquered wood or upholstered with leather per choice.

**TOP:** possibile legno noce canaletto finitura opaca chiara o scura; in legno laccato; oppure in marmo Travertino Silver Mano Leather o quarzite Taj Mahal e Acqua-quarzite.  
**BASE IN METALLO:** disponibile in tre finiture: Biotite spazzolato, Oro spazzolato e Bronzo spazzolato.  
**FUSTO:** possibile laccato o rivestito in pelle a scelta.

coffee and side table Gea  
tavolini Gea



**FEET AND TOP:** possible in canaletto walnut wood with light or dark matt finish; or choice between marble Travertino Silver Mano Leather or quartz Taj Mahal and Acqua-quarzite.  
**METAL INSERTS:** available with three finishes: Brushed Biotite, Brushed Gold and Brushed Bronze.

**PIEDI E TOP:** possibile in legno noce canaletto con finitura chiaro o scuro opaco; oppure in marmo Travertino Silver Mano Leather o quarzite Taj Mahal e Acqua-quarzite.  
**INSERTI METALLO:** disponibile in tre finiture: Biotite spazzolato, Oro spazzolato e Bronzo spazzolato.

BIG ROUND COFFEE TABLE Ø 80  
TAVOLINO ROTONDO Ø 80

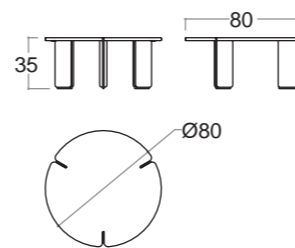

MARBLE TALL ROUND COFFEE TABLE Ø 45

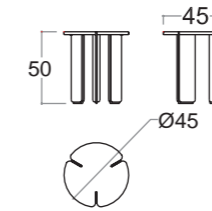

MARBLE LOUNGE ROUND COFFEE TABLE Ø 120

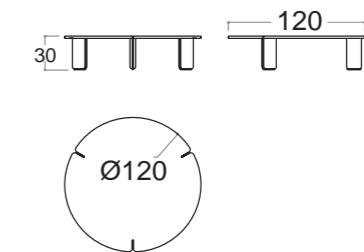

side table Glamis  
tavolino laterale Glamis

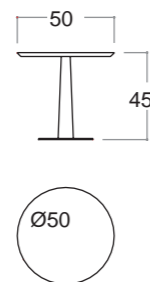
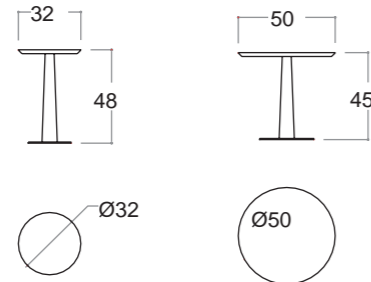

**TOP:** possible with canaletto walnut wood dark or light matt finish; lacquered wood; or choice between marble Travertino Silver Mano Leather or quartz Taj Mahal and Acqua-quarzite.  
**METAL BASE:** available with three finishes: Brushed Biotite, Brushed Gold and Brushed Bronze; possible with lacquered wood, or Canaletto walnut wood with dark or light matt finish.  
**STEM:** possible with lacquered wood, or Canaletto walnut wood with dark or light matt finish.

**TOP:** possibile legno noce canaletto finitura opaca chiara o scura; in legno laccato; oppure in marmo Travertino Silver Mano Leather o quarzite Taj Mahal e Acqua-quarzite.  
**BASE IN METALLO:** disponibile in tre finiture: Biotite spazzolato, Oro spazzolato e Bronzo spazzolato.  
**FUSTO:** possibile con legno laccato o in noce canaletto finitura opaca chiara o scura.

coffee and side table Gea  
tavolini Gea



**FEET AND TOP:** possible in Canaletto walnut wood with light or dark matt finish; or choice between marble Travertino Silver Mano Leather or quartz Taj Mahal and Acqua-quarzite.  
**METAL INSERTS:** available with three finishes: Brushed Biotite, Brushed Gold and Brushed Bronze.

**PIEDI E TOP:** possibile in legno noce canaletto con finitura chiaro o scuro opaco; oppure in marmo Travertino Silver Mano Leather o quarzite Taj Mahal e Acqua-quarzite.  
**INSERTI METALLO:** disponibile in tre finiture: Biotite spazzolato, Oro spazzolato e Bronzo spazzolato.

SQUARE COFFEE TABLE 120 MARBLE OR WOOD  
TAVOLINO QUADRATO 120 MARMO O LEGNO

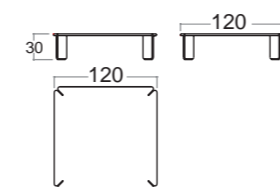

RECTANGULAR COFFEE TABLE 140x80 GEA MARBLE OR WOOD  
TAVOLINO RETTANGOLARE 140x80 MARMO O LEGNO

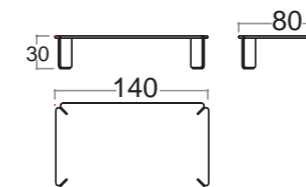

RECTANGULAR COFFEE TABLE 140x80 MARBLE OR WOOD  
TAVOLINO RETTANGOLARE 140x80 MARMO O LEGNO

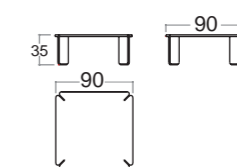

side table with drawer Sunda  
tavolino laterale Sunda

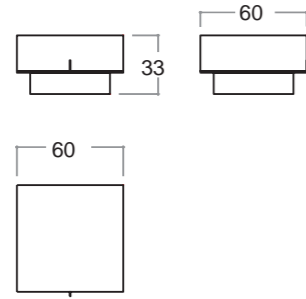

**ESTERNAL FRAME:**  
choise between marble  
Travertine Silver Mano  
Leather or quartz Taj  
Mahal and Acqua-  
quartzite  
**BASE AND INTERNAL  
DRAWER:**wood available  
with three finishes:  
Brushed Biotite, Brushed  
Gold and Brushed Bronze

**STRUTTURA ESTERNA:**  
possibile in marmo  
Travertino Silver Mano  
Leather o quarzite Taj  
Mahal e Acqua-quarzite.  
**BASE E CASSETTO  
INTERNO:** in legno  
disponibile in tre finiture:  
Biotite spazzolato, Oro  
spazzolato e Bronzo  
spazzolato

console Dune  
consolle Dune

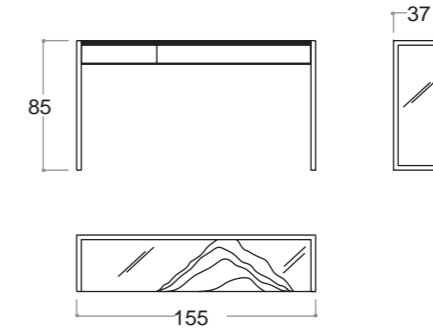

**FRAME:** metal available  
with three finishes:  
Brushed Biotite, Brushed  
Gold and Brushed Bronze.  
**INTERNAL SIDES AND  
TOP:** with Canaletto  
walnut wood possible  
light or dark matt finish.  
**EXTERNAL SIDES AND  
TOP:** bronzed mirror  
**INTERNAL DRAWER:**  
lacquered with bottom  
upholstered with  
microfiber.

**STRUTTURA:** in legno  
noce canaletto possibile  
con finitura opaco chiaro  
o scuro.  
**DETTAGLI:** metallo  
possibile in tre finiture:  
Biotite spazzolato, Oro  
spazzolato e Bronzo  
spazzolato.  
**CASSETTO INTERNO:**  
laccato con fondo rivestito  
in microfibra.  
**FIANCHI LATERALI  
ESTERNI E TOP:** specchio  
bronzato

coffee table Rock  
tavolino Rock



**TOP:** extra-clair  
transparent glass  
**FRAME:** metal  
**DETAIL:** rocks

**TOP:** vetro extra-chiaro,  
**STRUTTURA:** in metallo  
**DETTAGLIO:** roccia

low cabinet Tara  
madia Tara

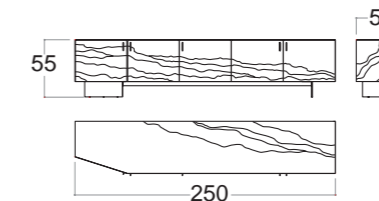

**FEET:** metal available with  
three finishes: Brushed  
Biotite, Brushed Gold  
and Brushed Bronze.  
**FRAME:** 4 inleid woods,  
dark or light finish.  
**HANDLES:** metal available  
with three finishes:  
Brushed Biotite,  
Brushed Gold and  
Brushed Bronze.  
**SHELF:** extra-clair  
transparent glass  
**LED LIGHT:** warm light

**PIEDI:** metallo disponibile  
in tre finiture: Biotite  
spazzolato, Oro spazzolato  
e Bronzo  
spazzolato.  
**STRUTTURA:** 4 legnli  
intarsiati, possibile chiaro  
o scuro .  
**MANIGLIE:** metallo  
disponibile in tre finiture:  
Biotite spazzolato, Oro  
spazzolato e Bronzo  
spazzolato.  
**RIPIANO:** vetro  
trasparente extra-chiaro.  
**LUCE AL LED:** luce calda

console Yuma  
consolle Yuma

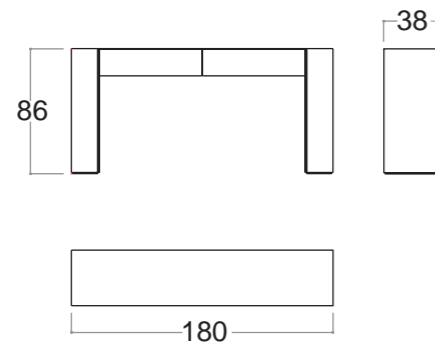

**ESTERNAL FRAME:**  
choise between marble  
Travertino Silver Mano  
Leather or quartz Taj  
Mahal and Acqua-  
quartzite.  
**DETAILS:** metal available  
with three finishes:  
Brushed Biotite, Brushed  
Gold and Brushed Bronze.  
**SHELF:** bronzed glass.  
**INTERNAL DRAWER:**  
lacquered with bottom  
upholstered with  
microfiber.

**STRUTTURA ESTERNA:**  
possibile in marmo  
Travertino Silver Mano  
Leather o quarzite Taj  
Mahal e Acqua-quarzite.  
**DETTAGLI:** metallo  
possibile in tre finiture:  
Biotite spazzolato, Oro  
spazzolato e Bronzo  
spazzolato.  
**RIPIANO:** vetro bronzato  
**CASSETTO INTERNO:**  
laccato con fondo rivestito  
in microfibra.

low cabinet Glamis  
madia Glamis

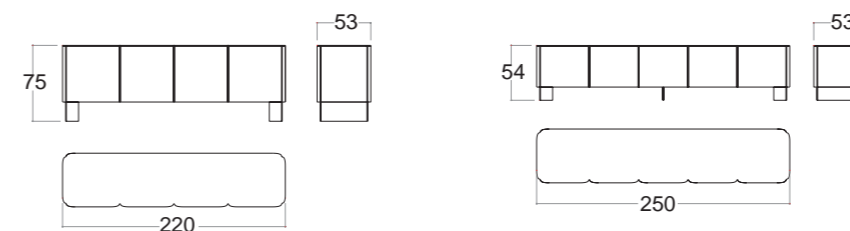

**FRAME:** canaletto walnut  
wood with light or dark  
matt finish doors with  
push and pull opening.  
**FEET:** metal available with  
three finishes: Brushed  
Biotite, Brushed Gold  
and Brushed Bronze.  
**SHELF:** extra-clair  
transparent glass  
**LED LIGHT:** warm light

**STRUTTURA:** possibile in  
legno noce canaletto con  
finitura chiara o scura  
opaca, sportelli con  
apertura push and pull.  
**PIEDI:** metallo disponibile  
in tre finiture: Biotite  
spazzolato, Oro spazzolato  
e Bronzo spazzolato.  
**RIPIANO:** vetro  
trasparente extra-chiaro.  
**LUCE AL LED:** luce calda

glass cabinet Dune  
vetrina Dune

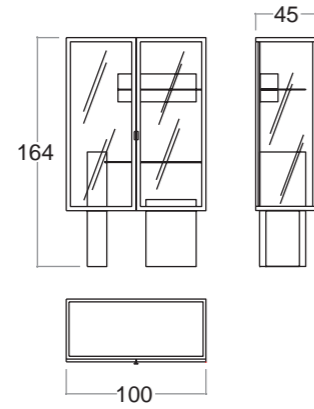

**BACK:** Canaletto walnut wood with light or dark matt finish; possible with leather upholstery as per choice

**TOP:** Canaletto walnut wood with light or dark matt finish.

**BASE AND SHELF SUPPORT:** choice between marble Travertine Silver Mano Leather or quartz Taj Mahal and Acqua-quartzite.

**FRAME:** available with three finishes: Brushed Biotite, Brushed Gold and Brushed Bronze.

**.DOORS, SIDES AND SHELVES:** made of extra-clear transparent glass.

**BOTTOM:** natural mirror.  
**LED LIGHT:** warm led light

**RETRO:** in legno canaletto noce con finitura chiara o scura opaca.

**TOP:** in legno canaletto noce con finitura chiara o scura opaca.

**BASE E SUPPORTO RIPIANO PER VETRINA:** in marmo Travertino Silver Mano Leather o quartzite Taj Mahal e Acqua-quartzite.

**STRUTTURA:** disponibile in tre finiture: Biotite spazzolato, Oro spazzolato e Bronzo spazzolato.

**ANTE, FIANCHI E RIPIANI:** in vetro trasparente extra-chiaro.

**FONDO:** specchio naturale  
**LUCE AL LED:** luce calda.

low cabinet Dune  
mobile basso Dune

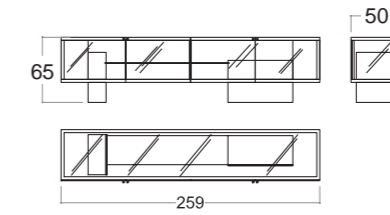

**BACK:** Canaletto walnut wood with light or dark matt finish; possible with leather upholstery as per choice

**BASE:** choice between marble Travertine Silver Mano Leather or quartz Taj Mahal and Acqua-quartzite.

**FRAME:** available with three finishes: Brushed Biotite, Brushed Gold and Brushed Bronze.

**.DOORS, SIDES AND SHELVES:** made of extra-clear transparent glass.

**BOTTOM:** natural mirror.  
**LED LIGHT:** warm led light

**RETRO:** in legno canaletto noce con finitura chiara o scura opaca.

**BASE:** in marmo Travertino Silver Mano Leather o quartzite Taj Mahal e Acqua-quartzite.

**STRUTTURA:** disponibile in tre finiture: Biotite spazzolato, Oro spazzolato e Bronzo spazzolato.

**ANTE, FIANCHI E RIPIANI:** in vetro trasparente extra-chiaro.

**FONDO:** specchio naturale  
**LUCE AL LED:** luce calda.

sideboard Glamis  
madia Glamis

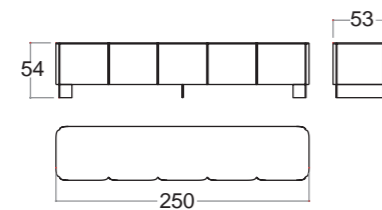
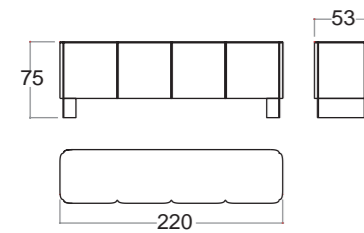

**FRAME:** canaletto walnut wood with light or dark matt finish doors with push and pull opening.

**FEET:** metal available with three finishes: Brushed Biotite, Brushed Gold and Brushed Bronze.

**SHELF:** extra-clair transparent glass

**LED LIGHT:** warm light

**STRUTTURA:** possibile in legno noce canaletto con finitura chiara o scura opaca, sportelli con apertura push and pull.

**PIEDI:** metallo disponibile in tre finiture: Biotite spazzolato, Oro spazzolato e Bronzospazzolato.

**RIPIANO:** vetro trasparente extra-chiaro.  
**LUCE AL LED:** luce calda.

sideboard Tara  
madia Tara

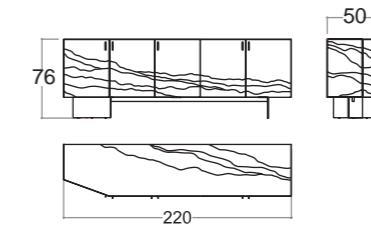

**FEET:** metal available with three finishes: Brushed Biotite, Brushed Gold and Brushed Bronze.

**FRAME:** 4 inleid woods, dark or light finish.

**HANDLES:** metal available with three finishes: Brushed Biotite, Brushed Gold and Brushed Bronze.

**SHELF:** extra-clair transparent glass  
**LED LIGHT:** warm light

**PIEDI:** metallo disponibile in tre finiture: Biotite spazzolato, Oro spazzolato e Bronzo spazzolato.

**STRUTTURA:** 4 legni intarsiati, possibile chiaro o scuro.

**MANIGLIE:** metallo disponibile in tre finiture: Biotite spazzolato, Oro spazzolato e Bronzo spazzolato.

**RIPIANO:** vetro trasparente extra-chiaro.  
**LUCE AL LED:** luce calda.

round table Gea  
tavolo rotondo Gea



**TOP AND LAZY SUSAN:** possible with canaletto walnut wood, with light or dark matt finish or choose between marble Travertino Silver Mano Leather or quartz Taj Mahal and Acqua-quarzite.  
**METAL BASE:** available with three finishes: Brushed Biotite, Brushed Gold and Brushed Bronze.  
**STEM:** lacquered or upholstered with leather per choice.

**TOP E LAZY SUSAN:** possibile in legno canaletto con finitura noce chiaro o scuro opaco; oppure in marmo Travertino Silver Mano Leather o quarzite Taj Mahal e Acqua-quarzite.  
**BASE IN METALLO:** disponibile in tre finiture: Biotite spazzolato, Oro spazzolato e Bronzo spazzolato.  
**FUSTO:** laccata o rivestita in pelle a scelta.

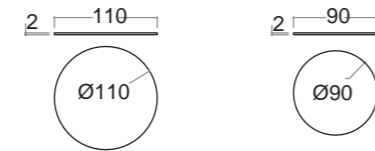
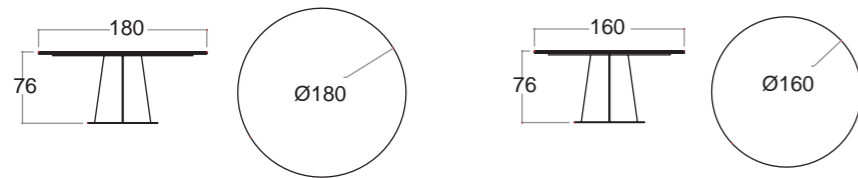

LAZY SUSAN GEA

rectangular table Gea  
tavolo rettangolare Gea



**FEET AND TOP:** canaletto walnut wood with light or dark matt finish  
**METAL INSERTS:** available with three finishes: Brushed Biotite, Brushed Gold and Brushed Bronze.  
**FEET:** possible with leather upholstery or Canaletto walnut wood with light or dark matt finish

**PIEDI E TOP:** legno noce canaletto con finitura opaca chiaro o scuro  
**INSERTI METALLO:** disponibile in tre finiture: Biotite spazzolato, Oro spazzolato e Bronzo spazzolato.  
**PIEDI:** possibile con rivestimento in pelle o legno noce canaletto finitura opaca chiara o scura

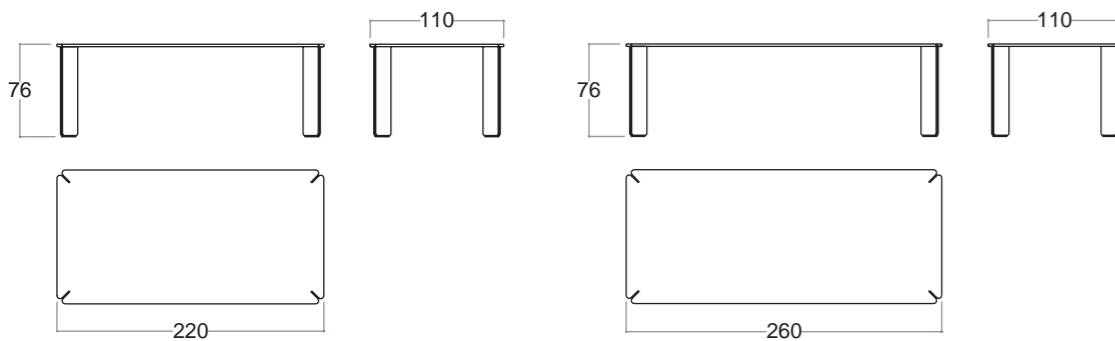

table Tara  
tavolo Tara



MARBLE /WOOD TABLE TARA

MARBLE TABLE TARA

**TOP:** canaletto walnut wood with light or dark matt finish; or choose between marble Travertino Silver Mano Leather or quartz Taj Mahal and Acqua-quarzite.  
**WOODEN TOP DETAIL:** detail with variable beveling.  
**BASE:** choose between marble Travertino Silver Mano Leather or quartz Taj Mahal and Acqua-quarzite.

**TOP:** legno noce canaletto con finitura opaca chiaro o scuro; oppure in marmo Travertino Silver Mano Leather o quarzite Taj Mahal e Acqua-quarzite.  
**DETTAGLIO TOP LEGNO:** dettaglio con bisellatura variabile.  
**BASE:** in marmo Travertino Silver Mano Leather o quarzite Taj Mahal e Acqua-quarzite.

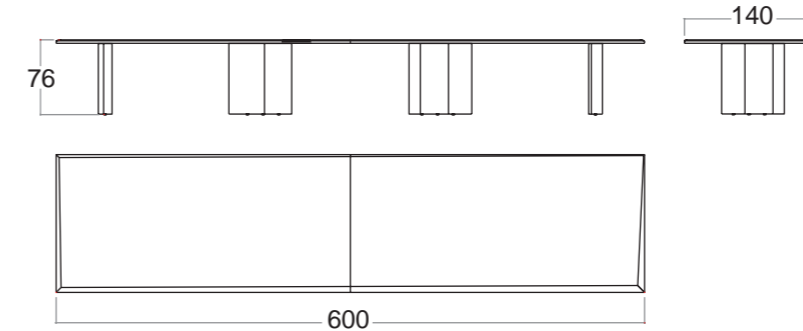
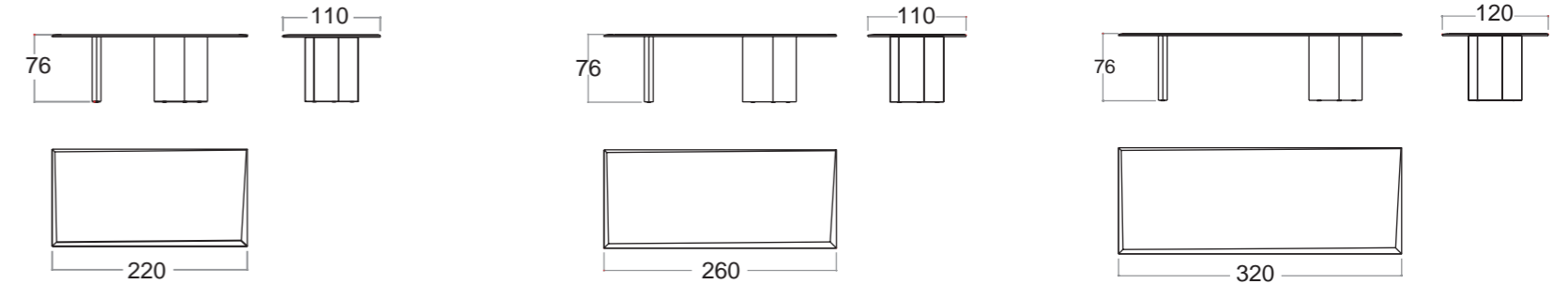

chair Yuma  
sedia Yuma

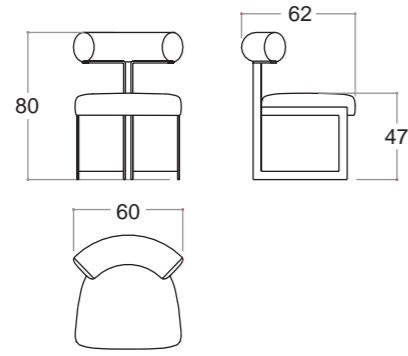

**FRAME:** metal with three finishes: Brushed Biotite, Brushed Gold and Brushed Bronze.  
**SEATS AND BACKS:** polyurethane foam.  
**UPHOLSTERY:** a choice of fabric or leather.

**STRUTTURA:** metallo in tre finiture: Biotite spazzolato, Oro spazzolato e Bronzo spazzolato  
**SEDUTE E SCHIENALI:** poliuretano espanso.  
**RIVESTIMENTO:** pelle o tessuto a scelta.

chair Tara  
sedia Tara

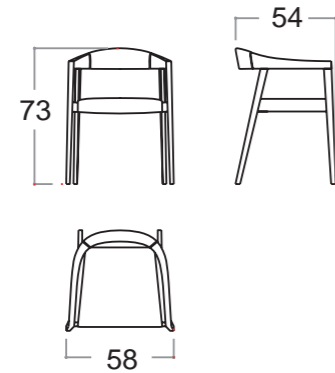

**FRAME:** solid wood with light or dark walnut finish.  
**SEATS AND BACKS:** polyurethane foam.  
**UPHOLSTERY:** a choice of fabric or leather.

**STRUTTURA:** legno massello con finitura in noce chiaro o noce scuro  
**SEDUTE E SCHIENALI:** poliuretano espanso.  
**RIVESTIMENTO:** pelle o tessuto a scelta.



# Technical data night elements | mobili zona notte

bed Dune  
letto Dune



**STRUCTURE:** Plywood  
**PADDING:** polyurethane foam.  
**UPHOLSTERY:** a choice of fabric or leather.  
**HEADBOARD DRAWERS AND BASE:** solid wood canaletto walnut with dark or light matt finish.  
**INTERNAL DRAWERS:** lacquered with bottom upholstered matching the headboard  
**HANDLES:** metal with three finishes: Brushed Biotite, Brushed Gold and Brushed Bronze.  
**DRAWER RUNNERS:** partial-extension runners with soft-close mechanism (blumotion)

**STRUTTURA:** multistrato.  
**IMBOTTITURA:** poliuretano espanso.  
**RIVESTIMENTO:** tessuto o pelle a scelta.  
**CASSETTI E BASE LETTO:** legno massello noce canaletto con finitura chiara o scura opaca.  
**CASSETTI INTERNI:** laccati con fondo rivestito come esterni.  
**MANIGLIE:** metallo con finiture: Biotite spazzolato, Oro spazzolato o Bronzo spazzolato.  
**GUIDE CASSETTI:** estrazione parziale con chiusura ammortizzata (blumotion)

bed Gea  
letto Gea



**STRUCTURE:** Plywood  
**PADDING:** polyurethane foam.  
**UPHOLSTERY:** a choice of fabric or leather.  
**FEET:** metal with three finishes: Brushed Biotite, Brushed Gold and Brushed Bronze.

**STRUTTURA:** multistrato.  
**IMBOTTITURA:** poliuretano espanso.  
**RIVESTIMENTO:** tessuto o pelle a scelta.  
**PIEDI:** metallo con finiture: Biotite spazzolato, Oro spazzolato o Bronzo spazzolato.

BED X SPRING 160X200  
LETTO PER RETE 160X200

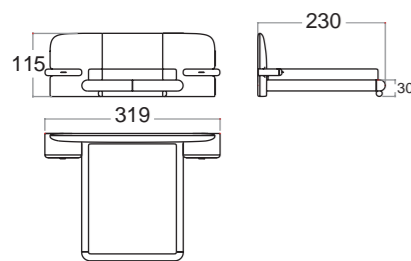

BED X SPRING QUEEN SIZE 152X203  
LETTO PER RETE QUEEN SIZE 152X203

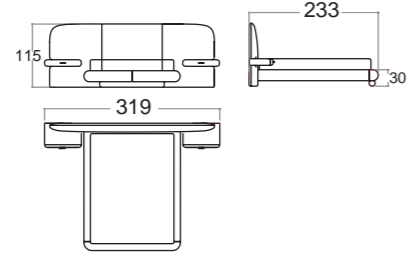

BED X SPRING 180X200  
LETTO PER RETE 180X200

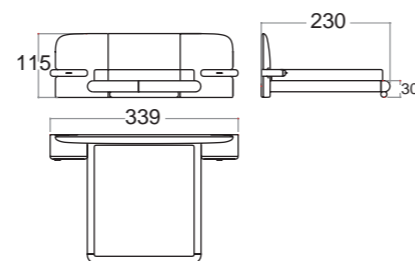

BED X SPRING 160X200  
LETTO PER RETE 160X200

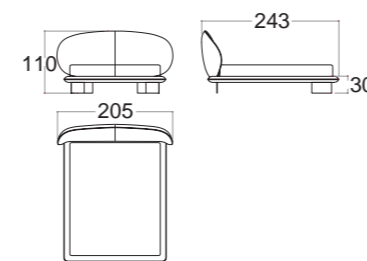

BED X SPRING QUEEN SIZE 152X203  
LETTO PER RETE QUEEN SIZE 152X203

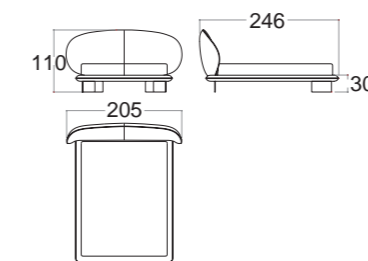

BED X SPRING 180X200  
LETTO PER RETE 180X200

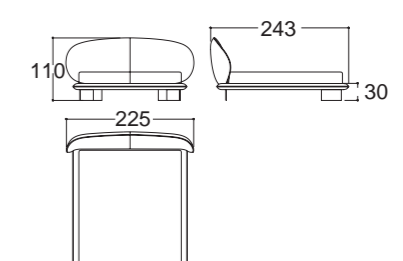

BED X SPRING 200X200  
LETTO PER RETE 200X200

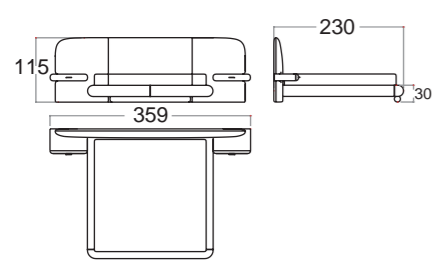

BED X SPRING KING SIZE 193X203  
LETTO PER RETE KING SIZE 193X203

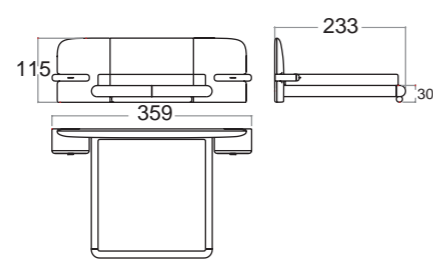

BED X SPRING 200X200  
LETTO PER RETE 200X200

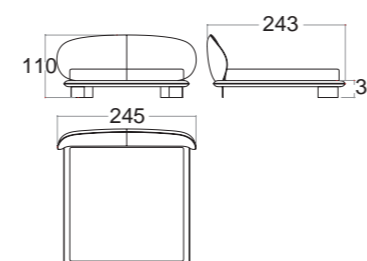

BED X SPRING KING SIZE 193X203  
LETTO PER RETE QUEEN SIZE 193X203

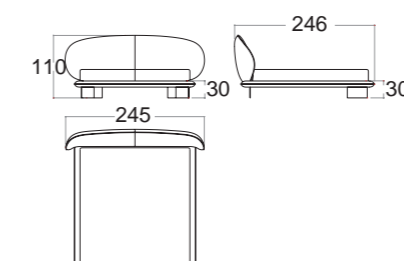

bed Namibia  
letto Namibia



**STRUCTURE:** Plywood  
**PADDING:** polyurethane foam.  
**UPHOLSTERY:** a choice of fabric or leather.  
**SHELF COMPARTMENT:** canaletto walnut wood with dark or light matt finish.  
**INTERNAL DRAWERS:** lacquered with upholstery matching the headboard.  
**HANDLES:** metal with three finishes: Brushed Biotite, Brushed Gold and Brushed Bronze.  
**LED LIGHT:** Warm light with touch switch.

**STRUTTURA:** multistrato.  
**IMBOTTITURA:** poliuretano espanso.  
**RIVESTIMENTO:** tessuto o pelle a scelta.  
**VANO A GIORNO:** legno noce canaletto con finitura chiara o scura opaca.  
**CASSETTI INTERNI:** laccati con fondo rivestito come esterni.  
**MANIGLIE:** metallo con finiture: Biotite spazzolato, Oro spazzolato o Bronzo spazzolato.  
**LUCE LED:** luce calda con interruttore a sfioramento.

vanity console Glamis  
toilette console Glamis

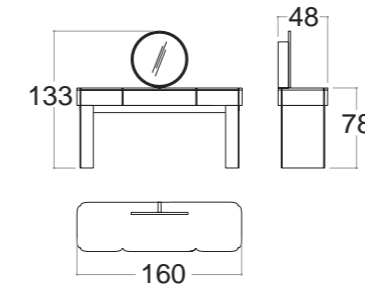

**EXTERNAL STRUCTURE:** upholstered with leather of your choice; or lacquered.  
**TOP:** Canaletto walnut wood with dark or light matt finish; or with marble Travertine Silver, or quartz Taj Mahal or Acqua-quartzite.  
**FEET:** metal possible in three finishes: Brushed Biotite, Brushed Gold and Brushed Bronze.  
**DRAWERS:** lacquered with bottom upholstered in microfiber.  
**MID-DRAWER PARTITION:** Canaletto walnut wood with dark or light matt finish with upholstered bottom.  
**DRAWER RUNNERS:** partial-extension drawer runners with soft-closing mechanism (BlueMotion).  
**CABINET HANDLES:** metal with three finishes: Brushed Biotite, Brushed Gold and Brushed Bronze.  
**SMALL VANITY WITH LEATHER AND WOODEN TOP (ONE CENTRAL DRAWER ONLY) GLAMIS**

**STRUTTURA ESTERNA:** rivestita con pelle a scelta o laccata.  
**TOP:** legno noce canaletto con finitura chiaro o scuro; o laccato, oppure con marmo Travertino Silver o quartzite Taj Mahal o Acqua-quartzite.  
**PIEDI:** possibile in tre finiture: Biotite spazzolata, Oro spazzolato e Bronzo spazzolato.  
**CASSETTI:** laccati con fondo rivestito in microfibra.  
**SEPARATORE CASSETTO CENTRALE:** legno noce canaletto con finitura chiaro o scuro con fondo rivestito.  
**GUIDE CASSETTI:** guide a estrazione parziale con meccanismo di chiusura ammortizzata (BlueMotion).  
**MANIGLIE:** possibile in tre finiture: Biotite spazzolata, Oro spazzolato e Bronzo spazzolato.  
**VANITY PICCOLO CON PELLE E TOP DI LEGNO (UN CASSETTO CENTRALE SOLTANTO) GLAMIS**

BED X SPRING 160X200  
LETTO PER RETE 160X200

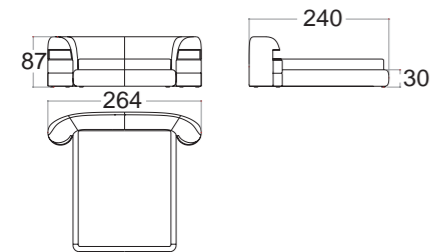

BED X SPRING QUEEN SIZE 152X203  
LETTO PER RETE QUEEN SIZE 152X203

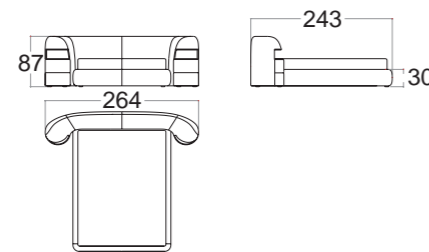

BED X SPRING 180X200  
LETTO PER RETE 180X200

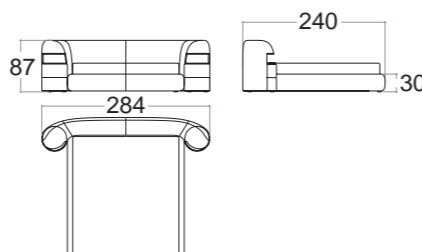

BED X SPRING 200X200  
LETTO PER RETE 200X200

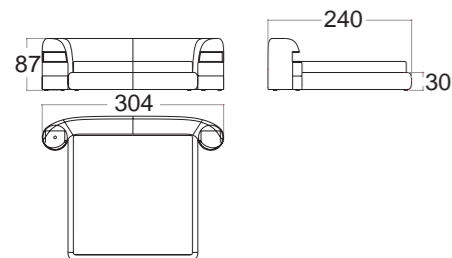

BED X SPRING KING SIZE 193X203  
LETTO PER RETE KING SIZE 193X203

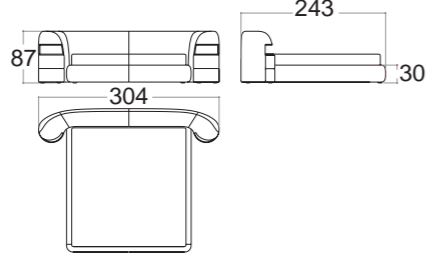

big vanity table Glamis  
toilette grande Glamis

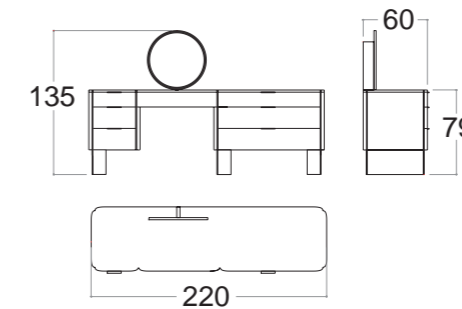

vanity table Glamis  
toilette Glamis

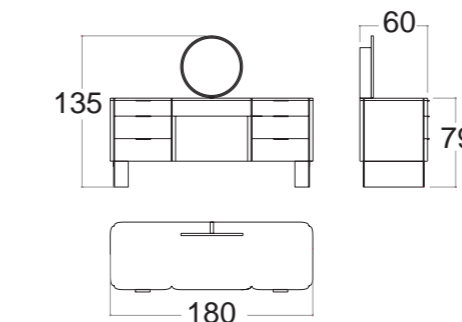

**EXTERNAL STRUCTURE:** upholstered with leather of your choice; or lacquered.  
**TOP:** Canaletto walnut wood with dark or light matt finish; or with marble Travertine Silver, or quartz Taj Mahal or Acqua-quartzite.  
**MID-DRAWER PARTITION:** Canaletto walnut wood with dark or light matt finish with upholstered bottom.  
**FEET:** metal possible in three finishes: Brushed Biotite, Brushed Gold and Brushed Bronze.  
**DRAWERS:** lacquered with bottom upholstered in microfiber.  
**DRAWER RUNNERS:** partial-extension drawer runners with soft-closing mechanism (BlueMotion).  
**CABINET HANDLES:** metal with three finishes: Brushed Biotite, Brushed Gold and Brushed Bronze.  
**LIGHT:** LED light with sensor switch.

**STRUTTURA ESTERNA:** rivestita con pelle a scelta o laccata.  
**TOP:** legno noce canaletto con finitura chiaro o scuro; oppure con marmo Travertino Silver o quartzite Taj Mahal o Acqua-quartzite.  
**SEPARATORE CASSETTO CENTRALE:** legno noce canaletto con finitura chiaro o scuro con fondo rivestito.  
**PIEDI:** possibile in tre finiture: Biotite spazzolata, Oro spazzolato e Bronzo spazzolato.  
**CASSETTI:** laccati con fondo rivestito in microfibra.  
**GUIDE CASSETTI:** guide a estrazione parziale con meccanismo di chiusura ammortizzata (BlueMotion).  
**MANIGLIE:** possibile in tre finiture: Biotite spazzolata, Oro spazzolato e Bronzo spazzolato.  
**LUCE:** LED con sensore per accensione

6 drawers dresser Glamis  
comò 6 cassetti Glamis

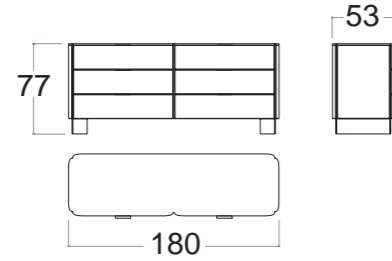

**EXTERNAL STRUCTURE:** upholstered with leather of your choice; or lacquered.  
**TOP:** canaletto walnut wood with dark or light matt finish; or lacquered, or with marble Travertine Silver, or quartz Taj Mahal or Acqua-quartzite.  
**FEET:** metal possible in three finishes: Brushed Biotite, Brushed Gold and Brushed Bronze.  
**DRAWERS:** lacquered with bottom upholstered in microfiber.  
**DRAWER RUNNERS:** partial-extension drawer runners with soft-closing mechanism (blumotion).

**STRUTTURA ESTERNA:** rivestita con pelle a scelta o laccata.  
**TOP:** legno noce canaletto con finitura chiaro o scuro; o legno laccato oppure con marmo Travertino Silver o quartzite Taj Mahal o Acqua-quartzite.  
**PIEDI:** possibile in tre finiture: Biotite spazzolata, Oro spazzolato e Bronzo spazzolato.  
**CASSETTI:** laccati con fondo rivestito in microfibra.  
**GUIDE CASSETTI:** guide a estrazione parziale con meccanismo di chiusura ammortizzata (blumotion).  
**MANIGLIE:** possibile in tre finiture: Biotite spazzolata, Oro spazzolato e Bronzo spazzolato.

night table Glamis  
comodino Glamis

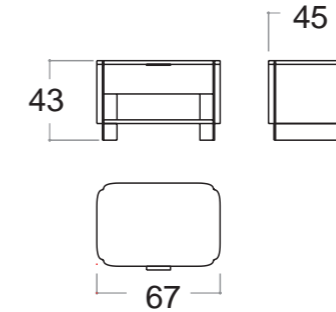

**EXTERNAL STRUCTURE:** upholstered with leather of your choice; or lacquered.  
**TOP:** Canaletto walnut wood with dark or light matt finish; or lacquered; or with marble Travertine Silver, or quartz Taj Mahal or Acqua-quartzite.  
**SHELF:** lacquered wood  
**FEET:** metal possible in three finishes: Brushed Biotite, Brushed Gold and Brushed Bronze.  
**DRAWERS:** lacquered with bottom upholstered in microfiber.  
**DRAWER RUNNERS:** partial-extension drawer runners with soft-closing mechanism (blumotion).  
**CABINET HANDLES:** metal with three finishes: Brushed Biotite, Brushed Gold and Brushed Bronze.

**STRUTTURA ESTERNA:** rivestita con pelle a scelta o laccata.  
**TOP:** legno noce canaletto con finitura chiaro o scuro; o laccato, oppure con marmo Travertino Silver o quartzite Taj Mahal o Acqua-quartzite.  
**RIPIANO A VISTA:** legno laccato  
**PIEDI:** possibile in tre finiture: Biotite spazzolata, Oro spazzolato e Bronzo spazzolato.  
**CASSETTI:** laccati con fondo rivestito in microfibra.  
**GUIDE CASSETTI:** guide a estrazione parziale con meccanismo di chiusura ammortizzata (blumotion).  
**MANIGLIE:** possibile in tre finiture: Biotite spazzolata, Oro spazzolato e Bronzo spazzolato.

3 drawers dresser Glamis  
comò 3 cassetti Glamis

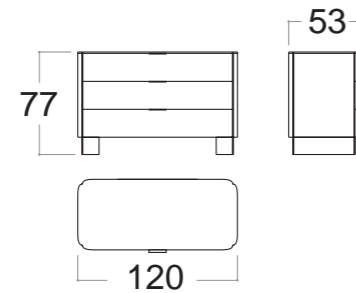

**EXTERNAL STRUCTURE:** upholstered with leather of your choice; or lacquered.  
**TOP:** Canaletto walnut wood with dark or light matt finish; or lacquered; or with marble Travertine Silver, or quartz Taj Mahal or Acqua-quartzite.  
**FEET:** metal possible in three finishes: Brushed Biotite, Brushed Gold and Brushed Bronze.  
**DRAWERS:** lacquered with bottom upholstered in microfiber.  
**DRAWER RUNNERS:** partial-extension drawer runners with soft-closing mechanism (blumotion).

**STRUTTURA ESTERNA:** rivestita con pelle a scelta o laccata.  
**TOP:** legno noce canaletto con finitura chiaro o scuro; o laccato, oppure con marmo Travertino Silver o quartzite Taj Mahal o Acqua-quartzite.  
**PIEDI:** possibile in tre finiture: Biotite spazzolata, Oro spazzolato e Bronzo spazzolato.  
**CASSETTI:** laccati con fondo rivestito in microfibra.  
**GUIDE CASSETTI:** guide a estrazione parziale con meccanismo di chiusura ammortizzata (blumotion).  
**MANIGLIE:** possibile in tre finiture: Biotite spazzolata, Oro spazzolato e Bronzo spazzolato.

column Forest  
Lampada Forest

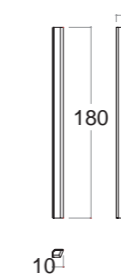

**ONYX LIGHT:** with white marble onyx  
**FRAME:** available with three finishes: Brushed Biotite, Brushed Gold and Brushed Bronze.

**COLONNA DI LUCE ONICE:** con marmo onice bianco  
**STRUTTURA:** disponibile in tre finiture: Biotite spazzolato, Oro spazzolato e Bronzo spazzolato.

**mirror Tara**  
specchio Tara

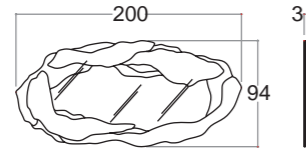

**MIRROR:** composed of multiple layers of mirror, standard and bronze colour and brushed Biotite metal inserts

**SPECCHIO:** composto da più strati di specchio, colore standard e bronzo ed inserti in metallo Biotite spazzolato

**carpet Rain Forest**  
tappeto Forest

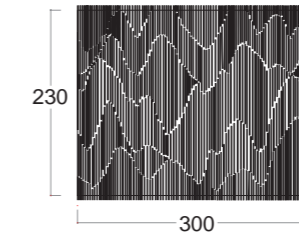
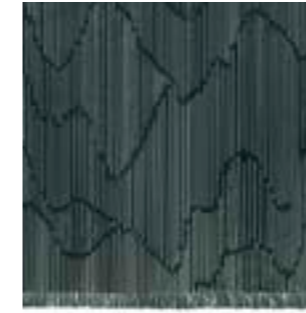

Made of wool and bamboo silk  
in lana e bamboo silk

**mirror Dune**  
specchio Dune

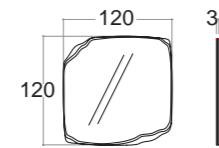
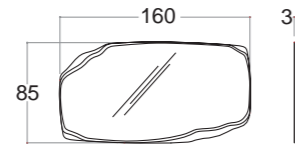
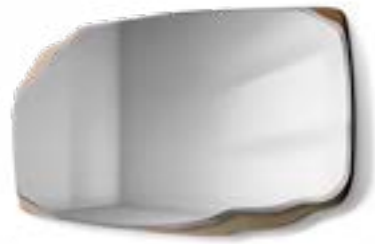

**BACK:** wood available in three finishes: Biotite brushed, Gold brushed, and Bronze brushed  
**MIRROR:** natural mirror.  
**DETAIL:** variable bevel

**RETRO:** in legno disponibile in tre finiture: Biotite spazzolato, Oro spazzolato e Bronzo spazzolato  
**SPECCHIO:** specchio naturale.  
**DETTAGLIO:** bisellatura variabile

**carpet Arenaria**  
tappeto Arenaria

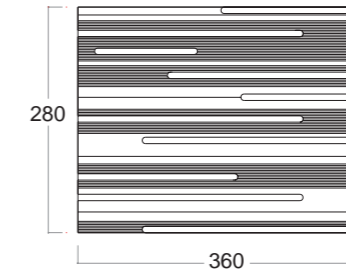

Made of bamboo silk  
in bamboo silk

**carpet Stone**  
tappeto Stone

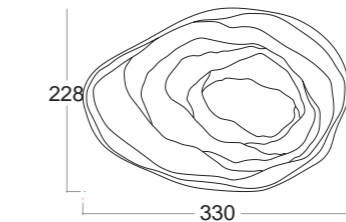

Made of wool and bamboo silk  
in lana e bamboo silk

**mirror Agata**  
specchio Agata

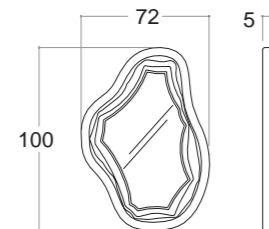

**MIRROR:** multiple layers of mirror with bronzed mirror and natural mirror.  
**FRAME:** lacquered wood; or upholstered with leather or velvet of choice.

**SPECCHIO:** più strati di specchio con specchio bronzato e specchio naturale.  
**STRUTTURA:** in legno laccato; oppure rivestito in pelle o velluto a scelta.

**carpet Dune**  
tappeto Dune

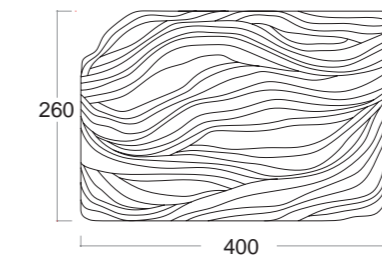

Made of bamboo silk  
in bamboo silk





**DUNE | comp 1**  
pag. 10 | 11

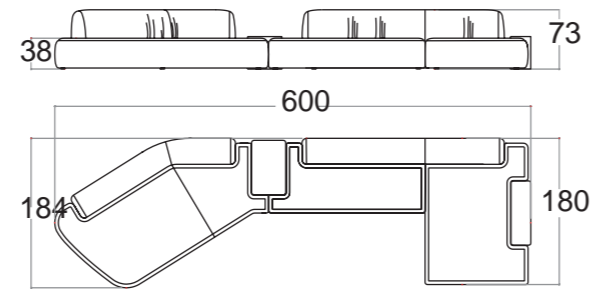

Dune sofa composition 2 upholstered with fabric Esopo 01 col. 01 (Cat. Extra Vip), and canaletto walnut wood tables with matt dark finish.  
(W.572 L.361 H. 73)  
(H. seater 38 cm)  
Decorative pillows with fabric Ecume col. 25 Cuivre (Cat. Extra Vip), fabric Esopo 01 col. 01 (Cat. Extra Vip), and velvet Kaori col. 2113 (Cat. Vip).

Divano Dune composizione 2 rivestito in tessuto Esopo 01 col. 01 (Cat. Extra Vip), e tavolini in legno noce canaletto scuro opaco.  
(L.572 L.361 H. 73 CM)  
Cuscini decorativi in: tessuto Ecume col. 25 Cuivre (Cat. Extra Vip), tessuto Esopo 01 col. 01 (Cat. Extra Vip), e velluto Kaori col. 2113 (Cat. Vip).



TV Support Tara with structure in 4 different tones of inlaid wood. Handles and base in gold brushed metal. Interior in dark wood and shelves in transparent extra-clear glass. Warm led light. (W.250 D.53 H.55 CM)

Base Tv Tara con struttura in 4 legni di toni diversi, intarsiati. Maniglie e base in metallo con finitura oro spazzolato. Interno in legno scuro e ripiani in vetro trasparente extra-chiaro. Luce led calda. (L.250 P.53 H.55 CM)



Dune carpet made of bamboo/silk  
(W.4 L.2,6 M)

Tappeto Dune, in bamboo/silk.  
(L.4 L.2,6 M)



Rectangular coffee table Dune: top with Taj Mahal quartz and metal frame with brushed gold metal finish.  
(W.155 D.75 H.30,5 cm)

Tavolino centrale Dune rettangolare con top in quarzite Taj Mahal e struttura in metallo oro spazzolato. (L.155 P.75 H.30,5 cm)



Glamis side table made of wood, lacquered with glossy finish and metal base with brushed gold finish.  
(D.50 H.45)

Tavolino Glamis (diametro 50 cm) in legno laccato lucido colorato e base in metallo con finitura oro spazzolato.  
(D.50 H.45 CM)



Sahara armchair seater upholstered with Kaori col. 2113 (Cat. Extra Vip) and back upholstered with leather Nabuk col.02. Metal back support with brushed gold finish.  
(W. 85 D.78 H.68 CM)

Poltrona Sahara con seduta rivestita in velluto Kaori col. 2113 (Cat. Extra Vip) e schienale rivestito in pelle Nabuk col. 2. Supporto schienale in metallo finitura oro spazzolato.  
(L. 85 P.78 H.68 CM)



Dune mirror with variable bevel and back with brushed gold finish. (W.160 D.2 H.85 CM)

Specchio Dune con bisellatura variabile e supporto con finitura oro spazzolato.  
(L.160 P.2 H.85 CM)



Yuma console made of Taj Mahal quartz, metal frame with brushed gold finish and shelf with bronzed glass.  
(W. 180 D.38 H.86 CM)

Consolle Yuma in quarzite Taj Mahal, metallo con finitura oro spazzolato e ripiano in vetro bronzato.  
(L. 180 P.38 H.86 CM)



**DUNE | comp 2**  
Pag 38 | 39

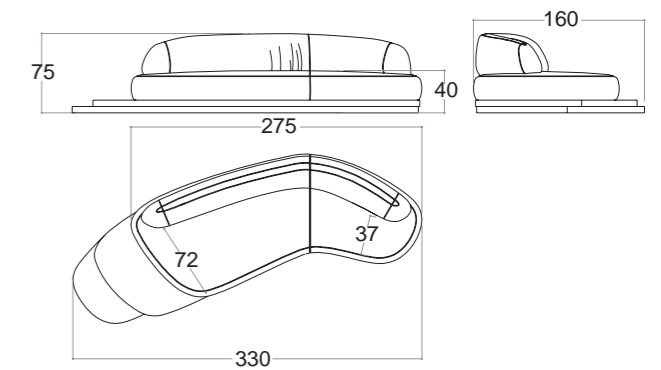

Glamis sofa upholstered with fabric Barletta col. 44 (Cat. Vip). Upper base Canaletto walnut wood with matt dark finish and lower base with brushed biotite metal finish.  
(W.330 D.160 H.75 CM)  
Decorative pillows with fabric Barletta col. 44 (Cat. Vip) and fabric Durango col.4 (Cat. Extra Vip).

Divano Glamis, rivestimento in tessuto Barletta col.44 (Cat. Vip). Base tavolino superiore in legno noce canaletto scuro opaco, base tavolino sotto con finitura metallo biotite spazzolato.  
(L.330 P.160 H.75 CM)  
Cuscini decorativi in Valletta col. 13 e in tessuto Barletta col.44 (Cat. Vip),



Tottori armchair with leather Vasco col.4 and metal frame with brushed gold finish.  
(W.55 P.62 H.66 CM)

Poltrona Tottori in pelle Vasco col. 4 e struttura in metallo con finitura oro spazzolato.  
(L.55 D.62 H.66 CM)



Gea side and coffee tables made with Taj Mahal quartz and metal detail with brushed biotite finish.  
1)D.80 H.45 CM  
2) D.45 H.50 CM

Tavolini Gea in quarzite Taj Mahal e metallo con finitura biotite spazzolato.  
1)D.80 H.45 CM  
2) D.45 H.50 CM



Dune console Canaletto walnut wood with matt dark finish, metal with brushed biotite finish and sides and top with bronzed mirror. Inside drawers with lacquered wood and bottom upholstered with matching microfiber.  
(W. 155 D.37 H.85 CM)

Consolle Dune in legno noce canaletto scuro opaco, metallo con finitura biotite spazzolato e specchi bronzo. Interno cassetti in legno laccato beige e fondo microfibra abbinata.  
(L. 155 P.37 H.85 CM)



Stone carpet made of bamboo/silk  
Tappeto Stone in lana e bamboo/silk.

**DUNE | comp 3**  
pag. 66 | 67



Gea round table: wooden top and lazy susan in canaletto walnut with dark matt finish, stem upholstered with leather Camoscio col.5, base with brushed biotite metal finish. (D.180 H. 76 cm)

Tavolo Gea con top e lazy Susan in legno noce canaletto scuro opaco, fusto con rivestimento in pelle Camoscio col. 31 e metallo con finitura Biotite spazzolato. (D.180 H. 76 cm)

Yuma chair upholstered with leather Camoscio col.31, metal frame with brushed biotite finish. (W.60 D.62 H.80 CM)

Sedie Yuma in pelle Camoscio col. 31 struttura in metallo con finitura biotite spazzolato. (L.60 P.62 H.80 CM)

Glamis sideboard with Canaletto walnut wood, metal feet and details with brushed biotite finish, inside shelf made of extra-clear transparent glass and warm led light. (W.220 D.53 H.75 CM)

Madia Glamis in legno noce canaletto scuro opaco, base e profili in metallo con finitura Biotite spazzolato, interno con ripiani in vetro trasparente extra-chiaro e luce led calda. (L.220 P.53 H.75 CM)

Tara mirror made of multilayer mirrors with natural and bronzed mirrors, and metal inserts with brushed biotite finish. (W.205,4 D.3 H.94 CM)

Specchio Tara composto da più strati di specchio colore standard e bronzo ed inserti in metallo con finitura Biotite spazzolato. (L.205,4 P.3 H.94 CM)

**DUNE | comp 4**  
pag. 86 | 87



Dune bed upholstered with leather Vasco col.5, side drawers and support made of Canaletto walnut wood with dark matt finish. Inside drawers lacquered with bottom upholstered with leather Vasco col. 5. Metal handles with brushed biotite finish.180X200 (W.339 D.230 H.115 CM)

Letto Dune rivestimento con pelle Vasco col. 5, cassetti laterali e base in legno massello noce canaletto con finitura scura opaca. Cassetti interni in legno laccato con fondo in pelle Vasco col.5. Maniglie in metallo con finitura biotite spazzolata. 180X200 (L.339 P.230 H.115 CM)

Vanity table Glamis upholstered with leather Vasco col. 5, top and partitioned central drawer with wood Canaletto walnut wood with matt dark finish and bottom with leather upholstery. Inside drawers lacquered with bottom upholstered with microfiber. Mirror with warm led light. (W.220 D.60 H.135 CM)

Vanity table Glamis rivestita in pelle Vasco col. 5 con top e cassetto centrale, attrezzato, in legno noce canaletto scuro opaco e fondo in pelle. Interno cassetti laterali in legno laccato beige e fondo in microfibra abbinata. Specchio con luce led calda.

Yuma chair upholstered with fabric Teddy col. 4 (Cat. Vip), metal frame with brushed biotite finish. (W.60 D.62 H.80 CM)

Sedia Yuma in tessuto Teddy col. 4 (Cat. Vip) e struttura in metallo con finitura biotite spazzolato. (L.60 P.62 H.80 CM)

Dune Island sofa upholstered with leather Vasco col.5 (W.212 D.177 H.73 CM). Pillows upholstered with fabric Ecume col. 73 dune (Cat. Extra Vip) and in leather Vasco col.5. Side tables with Canaletto walnut wood with matt dark finish.

Divano Isola Dune, rivestito in pelle Vasco col. 5 (L.212 P.177 H.73 CM). Cuscino decorativo in tessuto Ecume col. 73 Dune (Cat. Extra Vip). Tavolino in legno noce canaletto scuro opaco.

Arenaria carpet made of bamboo/silk.

Tappeto Arenaria in bamboo- silk



**FOREST | comp 5**  
pag. 106 | 107

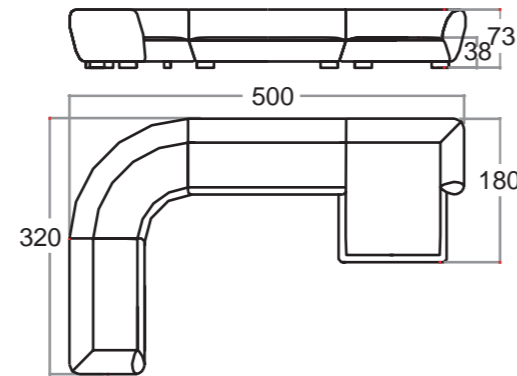

**FOREST | comp 6**  
pag. 134 | 135



Forest sofa composition 1 and Forest armchairs upholstered with fabric Magic Mirror I1768 col 200 corda (Cat. Lusso). Metal feet with brushed biotite finish. (W.500 L.320 H. 73 CM) (W.120 D.95 H.73 CM). Pillows upholstered with leather Nabuk col.2, fabric Magic Mirror I1768 col 200 corda (Cat. Lusso) and fabric Picasso col. 76 Bistre (Cat. Extra Vip).

Divano Forest composizione 1 e poltrone Forest rivestite in tessuto Magic Mirror I1768 col 200 corda (Cat. Lusso), piedi in metallo con finitura biotite spazzolato. (L.500 L.320 H. 73 CM) (L.120 P.95 H.73 CM). Cuscini decorativi in Nabuk col. 2, in tessuto Magic Mirror I1768 col 200 corda (Cat. Lusso) e in tessuto Picasso col. 76 Bistre (Cat. Extra Vip).



Gea side and coffee tables made with Taj Mahal quartz and metal detail with brushed gold finish. D.120 H.30 CM

Tavolino centrale Gea, in travertino Silver Mano Leather e metallo con finitura Biotite spazzolato. D.120 H.30 CM



Forest wall lamp made with white Onyx white marble and metal with brushed biotite finish. (W.10 D.7,6 H.180 CM)

Colonna di luce Forest in Onice bianco e metallo con finitura Biotite spazzolato. (L.10 P.7,6 H.180 CM)



Side table Sunda made of Travertine silver mano leather. Base, handle and inside drawer lacquered with brushed gold finish. (W. 60 D.60 H.33 CM)

Tavolino laterale Sunda in travertino Silver Mano Leather. Base, maniglia e cassetto interno con finitura Biotite spazzolato. (L. 60 P.60 H.33 CM)



Rain forest carpet made of wool and bamboo/silk

Tappeto Rain Forest in lana e bamboo/silk



Dune sideboard with frame and handles in brushed Biotite metal, back in Canaletto walnut with matt dark finish. Bases made of Travertine Silver mano leather marble. Sides, doors and shelves in transparent extra-clear glass. Mirror bottom. With warm led light. (W.259 D.45 H.65 CM)

Madia Dune con struttura e maniglie in metallo con finitura Biotite spazzolato, schienale in noce canaletto con finitura scura opaca. Basi in travertino Silver Mano Leather. Top, fianchi, ante e ripiano interno in vetro trasparente extra-chiaro. Fondo in specchio e con luce led caldo. (L.259 P.45 H.65 CM)



Yuma console made of Acqua-quarzite quartz, metal frame with brushed biotite finish and shelf with bronzed glass. (W. 180 D.38 H.86 CM)

Consolle Yuma in Acqua-quarzite, metallo con finitura biotite spazzolato e ripiano in vetro bronzo. (L. 180 P.38 H.86 CM)



Tara table top with Canaletto walnut wood with matt light finish, bases made of travertine silver mano leather marble. (W.260 D.110 H. 76 cm)

Tavolo Tara con top in noce canaletto con finitura chiara opaca. Basi in Biotite travertino Silver Mano Leather. (L.260 P.110 H.76 cm)



Chair Tara with leather Camoscio col.32 and solid wood structure with matt light walnut finish. (W. 58 D. 54 H.73 CM)

Sedie Tara in pelle Camoscio col.32 e struttura legno massello con finitura noce chiara opaca. (L. 58 P. 54 H.73 CM)



Tara sideboard with structure in 4 different tones of inlaid wood with light finish. Handles and base in gold brushed metal. Interior in dark wood and shelves in transparent extra-clear glass. Warm led light (W.220 D.50 H.76 CM)

Madia Tara con struttura in 4 legni di toni diversi, intarsiati, con finitura scura. Maniglie e base in metallo biotite spazzolato. Interno in legno chiaro e ripiani in vetro trasparente extra-chiaro. Luce led calda. (L.220 P.50 H.76 CM)



Dune glass cabinet with structure and handles in brushed Biotite metal, back in Canaletto walnut with matt light finish. Bases and shelf support made of Travertine Silver mano leather marble. Sides, doors and shelves in transparent extra-clear glass. Mirror bottom. With warm led light. (W.100 D.45 H.164 CM)

Vetrina Dune con struttura e maniglie in metallo con finitura Biotite spazzolato, schienale in noce canaletto con finitura chiara opaca. Basi porta ripiano in travertino Silver Mano Leather. Fianchi, ante e ripiani interni in vetro trasparente extra-chiaro. Fondo in specchio. Con luce led calda. (L.100 P.45 H.164 CM)



Namibia bed upholstered with leather Camoscio col.01, side shelf made of Canaletto wood with matt light finish. Inside drawers lacquered with bottom upholstered with leather Camoscio col.01. Warm led light in the shelf, Metal handles with brushed gold finish. (180x200) (W.284 D.240 H.87 cm)

Letto Namibia rivestito con pelle Camoscio col. 1, vano a giorno in legno noce canaletto con finitura chiara opaca. Cassetti interni laccati beige e fondo in pelle Camoscio col. 1. Luce calda con interruttore a sfioramento. Maniglie in metallo oro spazzolato. 180X200 (L.284 P.240 H.87 cm)



Gea side and coffee tables made with Taj Mahal quartz and metal detail with brushed gold finish. (D.80 H.35 cm)

Tavolino Gea in quarzite Taj Mahal e metalli con finitura oro spazzolato. (D.80 H.35 CM)



Small Vanity Glamis upholstered with leather Camoscio col.01, top and partitioned central drawer with wood Canaletto walnut wood with matt light finish and bottom with leather upholstery. Inside drawers lacquered with bottom upholstered with microfiber. Mirror with warm led light. Feet and details made of metal with brushed gold finish (W.160 D.60 H.133 CM)

Piccolo Vanity Glamis rivestita in pelle Camoscio col. 1, top in legno noce canaletto con finitura chiara opaca. Cassetto centrale con interno attrezzato, in legno noce canaletto chiaro opaco e fondo in microfibra. Basi e profili in metallo oro spazzolato. Specchio con luce led calda. (L.160 P.60 H.133 CM)



Chair Tara with leather Camoscio col.01 and solid wood structure with matt light walnut finish. (W. 58 D. 54 H.73 CM)

Sedia Tara rivestita in pelle Camoscio col. 1 e struttura in legno massello con finitura noce chiara opaca. (L. 58 P. 54 H.73 CM)



Sahara armchair with seat upholstered with fabric Spirituelle 2047 col.2(Cat. Extra Vip) and back upholstered with leather Camoscio col.1. Back support in brushed gold metal. (W. 85 D.78 H.68 CM)

Poltrona Sahara con seduta rivestita in tessuto Spirituelle 2047 col.2(Cat. Extra vip) e schienale rivestito in pelle camoscio col.1, supporto schienale in metallo con finitura oro spazzolato. (L. 85 P.78 H.68 CM)



3 drawers dresser upholstered with leather Camoscio col.01, top with wood Canaletto walnut wood with matt light finish. Metal feet and detail with brushed gold finish. Inside drawers lacquered with bottom upholstered with microfiber. (W.120 D.53 H.77 CM)

Comò 3 cassetti Glamis rivestito in pelle Camoscio col. 1, top in legno noce canaletto con finitura chiara opaca. Basi, maniglie e profili in metallo con finitura oro spazzolato. Interno cassetti laccati beige con fondo in microfibra abbinata. (L.120 P.53 H.77 CM)



Agata mirror with frame upholstered in leather Camoscio col.01 and multilayer mirrors made with standard and bronzed mirror. (W.70 D.55 H.100CM)

Specchio Agata con cornice in pelle Camoscio col. 1 con strati di specchi color bronzo e naturale. (L.70 P.55 H.100 CM)



**Dune sofa** upholstered with leather Vasco col.5 (L.572 L.361 H.73 CM) Pillows upholstered with fabric Ecume col. 73 dune (Cat. Extra Vip) and in leather Vasco col.5 Side tables with Canaletto walnut wood with matt light finish with Taj Majal quartz top. pp 16\_17



**Dune sofa** composition 1: seater upholstered with fabric Leon col. 04 (Cat. Extra Vip) and back upholstered with leather Polo col.0818. (W.600 W.194 H.73) (H. seater 38 cm) Pillows: fabric upholstery Kaori col. 2 (Cat. Extra Vip), leather upholstery Polo col.0818 and back with fabric Leon col. 04 (Cat. Extra Vip). Tables: Canaletto walnut wood with matt light finish. pp 20\_21



**Dune armchair** fabric upholstery 13524 Ecume col. 25 Cuivre (Cat. Extra Vip). (W.120 D.92 H. 73 CM) (H. seater 38 cm) pp 22



**Dune armchair** seater upholstered with fabric Momentum 13 Acute Tabacco/Slate 133496 (Cat. Extra Vip) and back upholstered with leather Nabuk col. 4. (W.120 D.92 H. 73 CM) (H. seater 38 cm) pp 23



**Dune coffee table:** con top in quarzite Taj Mahal e struttura in metallo biotite spazzolato. L.120 P.120 H. 31 cm pp 24\_25

**Divano Dune** rivestito in pelle Vasco col.5. (L.572 L.361 H.73 CM) Cuscini in tessuto Ecume col. 73 dune (Cat. Extra Vip) e in pelle Vasco col.5. Tavolino in legno noce canaletto chiaro opaco con top in quarzo Taj Mahal. pag 16\_17

**Divano Dune** composizione 1: seduta rivestita in tessuto Leon col. 04 (Cat. Extra Vip) e schienale rivestito in pelle Polo col.0818. (L.600 L.194 H.73) (H. seduta 38 cm) Cuscini: in tessuto Kaori col. 2 (Cat. Extra Vip), in pelle Polo col.0818 e retro in tessuto Leon col. 04 (Cat. Extra Vip). Tavolini: in legno noce canaletto chiaro opaco. pag 20\_21

**Poltrona Dune** rivestita in tessuto 13524 Ecume col. 25 Cuivre (Cat. Extra Vip). (L.120 P.92 H. 73 CM) (H. seduta 38 cm) pag 22

**Poltrona Dune** seduta rivestita in tessuto Momentum 13 Acute Tabacco/Slate 133496 (Cat. Extra Vip) e schienale rivestito in pelle Nabuk col.4. (L.120 P.92 H. 73 CM) (H. seduta 38 cm) pag 23

**Tavolino centrale Dune** top in quarzite Taj Mahal e struttura in metallo biotite spazzolato. (L.120 P.120 H. 31 cm) pag 24\_25



**Coffee table Glamis** Canaletto walnut wood with matt dark finish. Stem upholstered with Nabuk col.5 and metal base with brushed gold finish. (D. 90 H. 38 cm) pp 36



**Side Table Glamis** top with Taj Mahal quartz, stem canaletto walnut wood with matt dark finish and metal base with brushed gold finish. (D. 32 H. 48 cm) pp 37



**Glamis sofa with side table** upholstered with leather Camoscio Denim Brown col.46. (W. 255 D.116 H.75 CM) (H seater 40) Base: upper base Canaletto walnut wood with matt light finish and lower base with brushed gold metal finish. Pillows: fabric Poseidone WR L 1667 col.02 (Cat. Extra Lusso) with leather Camoscio Denim Brown col.46. pp 44\_45



**Glamis sofa with side table** fabric upholstery Meringa WP/AS L 1658 col.1 (Cat. Lusso). (W. 255 D.116 H.75 CM) (H seater 40) Base: upper base canaletto walnut wood with matt light finish and lower base with brushed gold metal finish. Pillows: fabric Poseidone WR L 1667 col.1 (Cat. Lusso) and fabric e in tessuto Meringa WP/AS L 1658 col.1 (Cat. Lusso). pp 46\_47



**Dune console** Canaletto walnut wood with matt light finish, metal with brushed biotite finish and sides and top with bronzed mirror. Inside drawers with lacquered wood and bottom upholstered with matching microfiber. (W. 155 D.37 H.85 CM) pp 54\_55

**Tavolino centrale Glamis:** con top in legno noce canaletto scuro opaco. Fusto rivestita in Nabuk col.5. base in metallo oro spazzolato. (D. 90 H. 38 cm) pag 36

**Tavolino laterale Glamis** con top in quarzite Taj Mahal. Base in legno noce canaletto scuro opaco e metallo oro spazzolato. (D. 32 H. 48 cm) pag 37

**Divano Glamis con tavolino** rivestito in pelle Camoscio Denim Brown col.46. (L. 255 P.116 H.75 CM) (H seduta 40) Base: superiore legno noce canaletto chiaro opaco e base inferiore finitura in metallo oro spazzolato. Cuscini: in tessuto Poseidone WR L 1667 col.1 (Cat. Lusso) e pelle Camoscio Denim Brown col.46 pag 44\_45

**Divano Glamis** rivestito in tessuto Meringa WP/AS L 1658 col.1 (Cat. Lusso). (L. 255 P.116 H.75 CM) (H seduta 40) Base: superiore legno noce canaletto chiaro opaco e base inferiore finitura in metallo oro spazzolato. Cuscini: in tessuto Poseidone WR L 1667 col.1 (Cat. Lusso) e in tessuto Meringa WP/AS L 1658 col.1 (Cat. Lusso). pag 46\_47

**Consolle Dune** in legno noce canaletto chiaro opaco, metallo con finitura biotite spazzolato e specchi bronzo. Interno cassetti in legno laccato beige e fondo microfibra abbinata. (L. 155 P.37 H.85 CM) pag 54\_55

**Tavolini Gea**

made with Taj Mahal quartz and metal detail with brushed gold finish. 1)D.80 H.35 CM 2) D.45 H.50 CM 3)D.120 H.30 CM pp 56\_57

**Tavolini Gea**

Tavolini Gea in quarzite Taj Mahal e dettaglio in metallo con finitura oro spazzolato. 1)D.80 H.35 CM 2) D.45 H.50 CM 3)D.120 H.30 CM pag 56\_57

**Square Gea central table**

with canaletto walnut wood canaletto walnut wood with matt dark finish and detail with brushed gold metal finish. (W.120 D.120 H. 31 cm) pp 60

**Tavolino centrale quadrato Gea**

in legno noce canaletto scuro opaco e dettaglio in metallo con finitura oro spazzolato. (L.120 P.120 H. 31cm) pag 60

**Square Gea central table**

made of travertine silver mano leather marble and detail with brushed gold metal finish (W.90 D.90 H 35 cm) pp 61

**Tavolino centrale quadrato Gea**

in travertino Silver mano Leather e dettaglio in metallo con finitura oro spazzolato. (L.90 P.90 H 35 cm) pag 61

**Rock side table**

top with extra-clear transparent glass, metal frame and rock details. (W.60 D.46 H.70 CM) pp 62\_63

**Tavolino Rock**

con top in vetro trasparente extra-chiaro, struttura in metallo dettaglio in roccia. (L.60 P.46 H.70 CM) pag 62\_63

**Gea round table:**

top with taj mahal quartz, stem upholstered with leather Nabuk col.5, base with brushed gold metal finish. (D.180 H. 76 cm) pp 74

**Tavolo Gea Tondo**

con top in quarzite Taj Mahal e fusto rivestito in pelle Nabuk col.5 e base in metallo con finitura oro spazzolato. (D.180 H. 76 cm) pag 74

**Gea table**

with wood Canaletto walnut wood with matt dark finish. Legs upholstered with leather Vasco col. 5 and detail with brushed gold metal finish. (W.260 D.110 H. 76 cm) pp 76\_77

**tavolo Gea**

top in legno noce canaletto scuro opaco. Gambe rivestite in pelle Vasco col.5 e dettaglio in metallo con finitura oro spazzolato. (L.260 P.110 H. 76 cm) pag 76\_77

**Yuma chair**

upholstered with fabric Tulum col.44 (Cat. Extra Vip), metal frame with brushed gold finish pp 78\_79

**Sedia Yuma**

rivestita con tessuto Tulum col. 44 (Cat. Extra Vip), struttura in metallo con finitura oro spazzolato. pag 78\_79

**Dune bed**

upholstered with fabric Gusto col.04 (Cat. Extra Lusso), side drawers and support made of Canaletto walnut wood with light matt finish. Inside drawers lacquered with bottom upholstered with fabric Gusto col.04. Metal handles with brushed biotite finish. (180x200) (W.339 D.230 H.115 CM) pp 92\_93

**Letto Dune**

rivestimento in tessuto Gusto col. 04 (Cat. Extra Lusso), cassetti laterali e supporto in legno noce canaletto con finitura opaca chiara. Cassetti interni laccati con fondo rivestito in tessuto Gusto col.04. Maniglie in metallo con finitura biotite spazzolato. (180x200) (L.339 P.230 H.115 CM) pag 92\_93

**Gea bed**

upholstered with fabric Alberto col.26 (Cat. Extra Vip), metal feet with brushed biotite finish. (180x200) (W.225 D. 243 H.110 CM) pp 94\_95

**Letto Gea**

rivestito in tessuto Alberto col.26 (Cat. Extra Vip) e piedini in metallo con finitura biotite spazzolato. (180x200) (L.225 P.243 H.110 CM) pag 94\_95

**Vanity table Glamis**

upholstered with leather Nabuk col.44, top and partitioned central drawer with wood Canaletto walnut wood with matt light finish and bottom with leather upholstery. Metal feet and detail with brushed biotite finish. Inside drawers lacquered with bottom upholstered with microfiber. Mirror with warm led light. (W.220 D.60 H.135 CM) pp 98\_99

**Toilette Glamis**

rivestita in pelle Nabuk col.44 con top e cassetto centrale, attrezzato, in legno noce canaletto chiaro opaco e fondo in pelle. Piedi e profili in metallo con finitura biotite spazzolato. Interno cassetti laterali in legno laccato beige e fondo in microfibra abbinata. Specchio con luce led calda. (L.220 P.60 H.135 CM) pag 98\_99

**Dune Island sofa**

upholstered with leather Vasco col.5 (W.212 D.177 H.73 CM) Pillows upholstered with fabric Ecume col. 73 dune (Cat. Extra Vip) and in leather Vasco col.5 Side tables with Canaletto walnut wood with matt dark finish pp 100\_101

**Divano Dune Isola**

rivestito in pelle Vasco col.5. (L.212 P.177 H.73 CM) Cuscini in tessuto Ecume col. 73 dune (Cat. Extra Vip) e in pelle Vasco col.5. Tavolino in legno noce canaletto scuro opaco. pag 100\_101

**Night table Glamis**

top with Taj Mahal quartz. Frame and shelf made of lacquered wood with Ivory finish. Inside drawers lacquered with bottom upholstered with microfiber. Metal feet and handle with brushed gold finish. (W.67 D.45 H.43 CM) pp 104

**Comodino Glamis**

con top in quarzite Taj Mahal. Struttura e ripiano a vista in legno laccato avorio. Interno cassetto laccato avorio e fondo cassetto in microfibra abbinato. Piedi e maniglia in metallo oro spazzolato. (L.67 P.45 H.43 CM) pag 104

**6 Drawers dresser Glamis**

top and frame made of lacquered wood with Ivory finish. Inside drawers lacquered with bottom upholstered with microfiber. Metal feet and handle with brushed gold finish. (W.180 D.53 H.77 CM) pp 104

**Comò Glamis 6 cassetti**

con top e struttura in legno laccato avorio. Interno cassetti laccato avorio e fondo cassetti in microfibra abbinato. Piedi e maniglie in metallo oro spazzolato. (L.180 P.53 H.77 CM) pag 104



**Forest sofa composition 2**  
upholstered with fabric Kelly col.17 (Cat. Vip). Metal feet with brushed biotite finish. (W.311 L.190 H. 73 CM) Pillows upholstered with fabric Catala col.18 (Cat. Extra Vip), fabric Kelly col.17 (Cat. Vip).  
pag 115



**3-seater sofa forest**  
upholstered with leather Nabuk col.16, Metal feet with brushed gold finish. (W.228 D. 95 H. 73 CM)  
pag 116\_117



**Forest armchair**  
seater upholstered with Momentum 13 Triadic Clay 133486 (Cat. Extra Vip) back upholstered with fabric Magic Mirror col.200 corda (Cat. Lusso). Metal feet with brushed gold finish. (W. 120 D.95 H.73 CM)  
pag 119



**Side table Sunda**  
made of Acqua-quarzite quartz. Base, handle and inside drawer lacquered with brushed gold finish. (W. 60 D.60 H.33 CM)  
pag 127



**Tv cabinet Glamis**  
with Canaletto walnut wood with matt dark finish, feet and detail with brushed biotite finish, inside shelf with extra-clear transparent glass and warn led light. (W.250 D.53 H.54 CM)  
pag 130\_131



**Tara table**  
top with Canaletto walnut wood with matt dark finish, bases made of travertine silver mano leather marble. (W.260 D.110 H. 76 cm)  
pag 138\_139\_140\_141



**Tara table**  
top with Canaletto walnut wood with matt dark finish, bases made of travertine silver mano leather marble. (W.600 D.140 H.76 CM)  
pag 142\_143

**Divano Forest composizione 2**  
rivestito in tessuto Kelly col.17 (Cat. Vip). Piedini in metallo biotite spazzolato. (L.311 L.190 H. 73 CM) Cuscini in tessuto Catala col.18 (Cat. Extra Vip), in tessuto Kelly col.17 (Cat. Vip).  
pag 115

**Divano Forest 3 posti**  
rivestito in pelle Nabuk col. 16 e piedi in metallo con finitura oro spazzolato. (L.228 P. 95 H. 73 CM)  
pag 116\_117

**Poltrona Forest**  
seduta rivestita in tessuto Momentum 13 Triadic Clay 133486 (Cat. Extra Vip), schienali in tessuto Magic Mirror col. 200 corda (Cat. Lusso) e piedi in metallo con finitura oro spazzolato. (L. 120 P.95 H.73 CM)  
pag 119

**Tavolino laterale Sunda**  
in acqua quarzite. Base, maniglia e interno cassetto con finitura laccato in oro spazzolato. (L. 60 P.60 H.33 CM)  
pag 127

**Base tv Glamis**  
in legno noce canaletto scuro opaco, base e profili in metallo Biotite spazzolato, interno con ripiano in vetro trasparente extra-chiaro e luce led calda. (L.250 P.53 H.54 CM)  
pag 130\_131

**Tavolo Tara**  
con top in noce canaletto con finitura scura opaca. Basi in travertino Silver Mano Leather. (L.260 P.110 H. 76 cm)  
pag 138\_139\_140\_141

**Tavolo Tara**  
con top in noce canaletto con finitura scura opaca. Basi in travertino Silver Mano Leather. (L.600 P.140 H. 76cm)  
pag 142\_143



**Tara table**  
made of Taj Mahal quartz (W.260 D.110 H. 76 cm)  
pag 144\_145



**Tara sideboard**  
with structure in 4 different tones of inlaid wood with dark finish. Handles and base in gold brushed metal. Interior in dark wood and shelves in transparent extra-clear glass. Warm led light (W.220 D.50 H.76 CM)  
pag 150\_151



**Dune glass cabinet**  
with structure in 4 different tones of inlaid wood with dark finish. Handles and base in gold brushed metal. Interior in dark wood and shelves in transparent extra-clear glass. Warm led light (W.220 D.50 H.76 CM)  
pag 150\_151



**Dune glass cabinet**  
with structure and handles in brushed Biotite metal, back in leather Polo col. 0832. Bases and shelf support made of acqua-quarzite quartz. Sides, doors and internal shelves in transparent extra-clear glass. Mirror bottom. With warm led light. (W.100 D.45 H.164 CM)  
pag 154\_155



**Chair Tara**  
with leather Camoscio col.32 and solid wood structure with matt dark walnut finish. (W. 58 D. 54 H.73 CM)  
pag 158\_159



**Sahara armchair**  
with seat upholstered with Amsterdam col. 48 (Cat. Extra Luxury) and back upholstered with leather Polo col. 832. Back support in brushed biotite metal. (W. 85 P.78 H.68 CM)  
pag 176\_177

**Tavolo Tara**  
in quarzite Taj Mahal. (L.260 P.110 H. 76 cm)  
pag 144\_145

**Madia Tara**  
con struttura in 4 legni di toni diversi, intarsiati, con finitura scura. Maniglie e base in metallo oro spazzolato. Interno in legno scuro e ripiani in vetro trasparente extra-chiaro. Luce led calda. (L.220 P.50 H.76 CM)  
pag 150\_151

**Vetrina Dune**  
con struttura e maniglie in metallo Biotite spazzolato, schienale in noce canaletto con finitura scura opaca. Basi porta ripiano in travertino Silver Mano Leather. Fianchi, ante e ripiani interni in vetro trasparente extra-chiaro. Fondo in specchio. Con luce led calda. (L.100 P.45 H.164 CM)  
pag 150\_151

**Vetrina Dune**  
con struttura e maniglie in metallo Biotite spazzolato, schienale in pelle Polo col. 832. Basi porta ripiano acqua quarzite. Fianchi, ante e ripiani interni in vetro trasparente extra-chiaro. Fondo in specchio. Con luce led calda. (L.100 P.45 H.164 CM)  
pag 156\_157

**Sedia Tara**  
in pelle Camoscio col.32 e struttura in legno massello con finitura noce scuro opaca. (L. 58 P. 54 H.73 CM)  
pag 158\_159

**Poltrona Sahara**  
con seduta rivestita in Amsterdam col. 48 (Cat. Extra Lusso) e schienale rivestito in pelle Polo col. 832. Supporto schienale in metallo biotite spazzolato. (L. 85 P.78 H.68 CM) (H. seduta 38 cm)  
pag 176\_177

Design **Lucia Ippoliti**  
Art Director  
Concept

Graphic design **Rodolfo Pompucci**  
impaginazione **(RING.it)**

Fotografia **Leon Studio**

Render 3d **Immagina**

Copy **Emanuela Sabbatini**

Fotolito **Lifeinpixel**

Stampa **Leardini**

Lampade:  
pp. 10 - 11 - 38 - 39 - 41  
66 - 67 - 86 - 89  
di Officina Luce.



MOBILPIÙ LUXURY s.r.l.  
Via XXV Aprile, 41/A - 61022 Montecchio di Vallefoglia (PU) Italia - T. +39 0721394306  
info@ivghomecollection.com - www.ivghomecollection.com

It is possible the use of different marbles in addition to our proposals but must necessarily be estimated and agreed with the company.

IVG Home collection specifies that the colours of materials, upholstery and finishes are for reference purposes only, as they are subject to processing and printing tolerances. Moreover, elements such as marble and leather, may differ from the images of the catalogue, being natural materials, and any differences are not to be considered defects but rather guarantee the uniqueness of the product.

The company also reserves the right to make changes to structural measures, materials, coatings and finishes for improvement purpose, without notice.

IVG Home Collection is included in the national register of Italian producers at the number: IT01.IT/2740.103.M

*L'inserimento di altre tipologie di marmo, oltre alle nostre proposte, è realizzabile ma deve essere necessariamente preventivato e concordato con l'azienda.*

*IVG Home Collection tiene a specificare che le texture e i colori dei materiali e delle finiture hanno valore puramente indicativo in quanto soggette alle tolleranze dei processi di stampa.*

*Inoltre, elementi come marmo e pellami, possono differire dalle immagini del catalogo in quanto materiali naturali ed eventuali differenze non sono da considerarsi difetti ma bensì garanzia dell'unicità del prodotto.*

*L'azienda si riserva inoltre di apportare, senza preavviso, modifiche di misure strutturali, materiali, rivestimenti e finiture a scopo migliorativo.*

*IVG Home Collection è inserito nel registro nazionale dei produttori italiani al numero: IT01.IT/2740.103.M*



