

*Caos creativo*<sup>®</sup>

HUMAN DESIGN EXPERIENCE



LIBRERIA ALL-OVER ALL-OVER BOOKCASE

WALL DECOR

LIBRERIA ALL-OVER  
ALL-OVER BOOKCASE

# LIBRERIA ALL-OVER

We Believe	04
Living solution	08
Entrance and corridor	30
Kitchen solution	36
Bedroom	44
Bathroom	48
Office	56
Modularity - Finishes	60



# WELCOME TO CAOS CREATIVO

Il mondo di Caos creativo è dinamico, sempre aperto a nuove idee, ispirazioni e proposte per valorizzare gli spazi abitativi ed espositivi. Il nostro progetto di libreria modulare e sospesa entra in tutti gli ambienti della casa per arredare pareti libere e custodire liberamente libri o altri oggetti con originalità, leggerezza e personalità.

Caos creativo's world is dynamic, always open to new ideas, inspirations and offerings to enhance living and showroom spaces. Our modular wall-hung shelving unit can furnish any room in the home, adding character, decorating walls and storing books or other objects in an original, visually-light way.

# WE BELIEVE

## IL NOSTRO MANIFESTO

---

Siamo un team di professionisti e designer e Caos creativo è il brand che abbiamo fortemente voluto. Un progetto di design che ha alle spalle l'esperienza progettuale di **Rossi&Co**. In ogni scelta che facciamo e in ogni prodotto che sviluppiamo ci sono cinque punti che ci tengono uniti e che formano il nostro manifesto per un design fatto di gioco, gentilezza e dettagli.

We are a team of professionals and designers and Caos creativo is the brand that we really wanted. A design project that has behind it the design experience of **Rossi&Co**. In every choice we make and in every product we develop there are five points that hold us together and form our manifesto for a design made up of play, kindness and detail.

## \_ DETAILS MATTER

---

I dettagli fanno la differenza. Si può anche scegliere un divano moderno o recuperare il mobile della nonna, quello che conta è valorizzarlo con una carta da parati su misura o con un tavolino di design. **Per un arredo unico.**

Details really do make a difference. You can even choose a modern sofa or salvage your grandma's old one, but what will really count is your ability to enhance it with custom wallpaper or with a designer coffee table. That's what will make your **interior decor genuinely unique.**

## \_ WE ARE BORN TO HAVE FUN

---

Il nostro brand è nato per esprimere la nostra creatività. Libertà progettuale, spensieratezza, piacevolezza, creatività: sono queste le parole fondanti di Caos creativo. **Siamo nati per divertirci.**

Our brand was born to express our creativity. Design freedom, a carefree spirit, amiability and creativity: these are the concepts Caos creativo is cemented on. **We were born to have fun.**

## \_ BE NICE AND BE KIND

---

In questo punto c'è il nostro modo speciale di fare le cose: con gentilezza. Siamo un team che nel servizio di consulenza e assistenza ha trovato la sua forza. Vogliamo che chi sceglie i nostri prodotti **si senta sempre accolto.**

This point explains our particular way of doing things, i.e. kindly. Our team bases its strength on our consultancy and assistance service. We want everyone who chooses our products to **feel really welcome.**

## \_ HUMAN FIRST

---

Dietro Caos creativo ci sono delle persone che progettano e creano per altre persone, con la direzione artistica di Rossi&Co, dove il design **mette al centro l'uomo e lo segue nel suo quotidiano.**

Behind Caos creativo there are people who design and create for other people, with the artistic direction of Rossi&Co, where design **puts people at the centre and follows them in their daily lives.**

## \_ NOBODY'S PERFECT

---

Vogliamo entrare nelle case, alberghi, ristoranti e negozi di tutti. E non è un problema se aprendo la porta qualcosa sarà fuori posto. L'importante è che ci sia il **gusto e l'identità di chi si prende cura dei propri spazi.**

We want to be part of everyone's home, hotel, restaurant and shop. And it's not a problem if things aren't in place when you open the door. The only important things that need to be in place are **the taste and identity of the person taking care of the space.**

# WE ARE HUMANS

Caos creativo è un brand di design 100% pensato e prodotto in Italia, che progetta e realizza decorazioni per pareti e arredo per case, alberghi, ristoranti e negozi. La nostra idea di arredo mette al centro le persone e il loro desiderio di abitare un luogo in cui ogni dettaglio ha la sua importanza. Prendiamo ispirazione da un'idea di design gioioso, conviviale, colorato, che apre le porte e si lascia contaminare da stili diversi, senza mai essere snob.

Caos creativo is a designer brand completely invented and produced in Italy that designs and makes wall decors and furniture for homes, hotels, restaurants and shops. Our idea of furniture focuses on people and on their desire to live in a place that gives the right importance to every detail. We get our inspiration from a joyful, convivial, colourful concept of design that is open to - and lets itself be contaminated by - different styles without ever becoming lofty.

*Caos creativo*<sup>®</sup>

HUMAN DESIGN EXPERIENCE

## ALL-OVER

Molto più di una semplice libreria, All-Over è un arredo da comporre a piacere e da posizionare ovunque. Dalla zona giorno alla camera da letto, dalla cucina al bagno, dall'ingresso all'ufficio: qualunque sia la stanza e qualsiasi sia lo spazio, la libreria perfetta c'è.

Much more than a bookcase, All-Over is a shelving unit that can be put together as you prefer and positioned anywhere you please. In the living room or bedroom, in the kitchen or bathroom and in the entrance hall or the office: there's a perfect shelving unit for any room and any space.



# LIVING SOLUTIONS

Vicino a delle poltrone per avere i libri a portata di mano, su una parete attrezzata per completarne la funzionalità, dietro a un divano per creare arredi originali che sembrano opere d'arte: la libreria All-Over non mette limiti agli spazi e alla creatività.

Next to an armchair to keep your books within reach, in a wall arrangement to complete its functions, behind a sofa to create original compositions that look like works of art: the All-Over shelving unit never limits your spaces or your creativity.

## Configuration 01

---

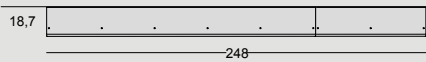
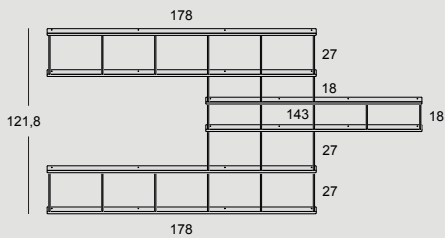



# LIVING SOLUTIONS

## Configuration 02

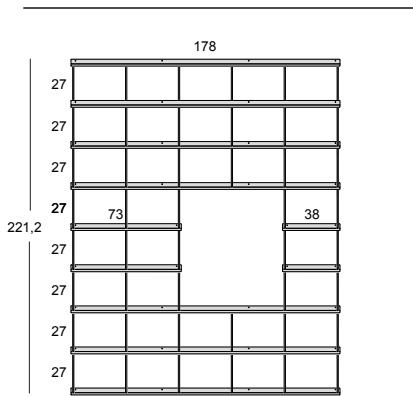

## Configuration 03

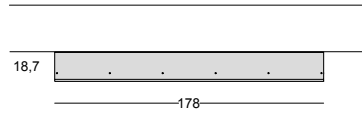
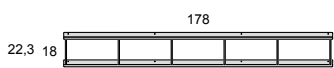







# LIVING SOLUTIONS



Configuration 05

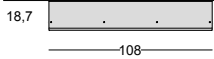
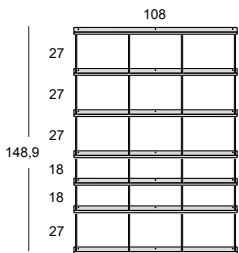



# LIVING SOLUTIONS

Configuration 06 - 07

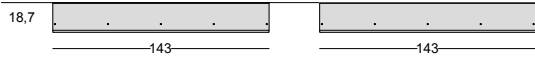
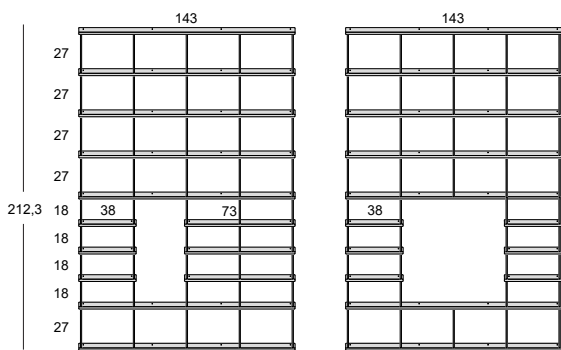



# LIVING SOLUTIONS

## Configuration 08

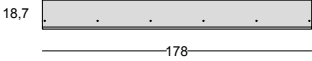
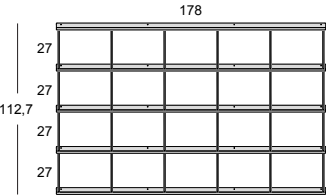



# LIVING SOLUTIONS

Configuration 09

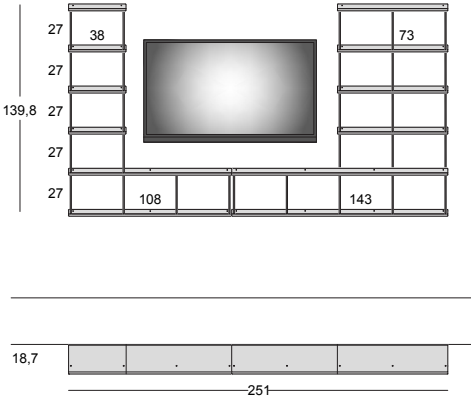



# LIVING SOLUTIONS

## Configuration 10

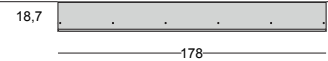
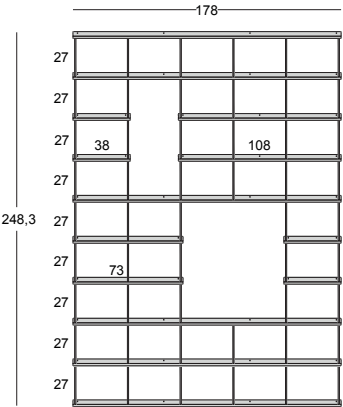







**Configuration 11-12-13**

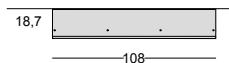
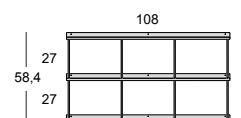





# LIVING SOLUTIONS

Configuration 15

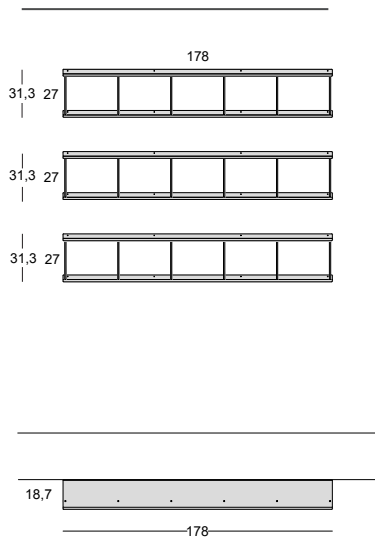



# ENTRANCE AND CORRIDOR

In ogni casa ci sono zone “mute” che hanno bisogno di esprimersi: la modularità di All-Over permette di dare voce a ingressi e pareti bianche con piccoli progetti dal grande stile. Sopra una madia o una panchetta, la libreria fa sempre la sua bella figura.

Every home has “voiceless” areas that have not yet expressed themselves: All-Over’s modules give a voice to entrances and white walls in great style through small projects. A shelving unit always looks good above a sideboard or wall-hung unit.

## Configuration 16

---

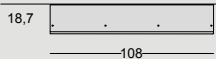
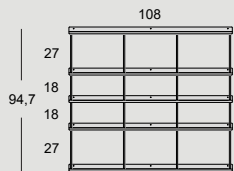



# ENTRANCE AND CORRIDOR

Configuration 17

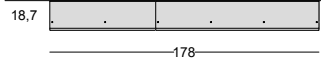
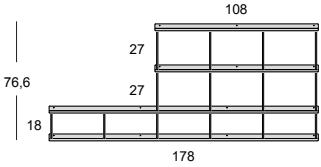





Configuration 18

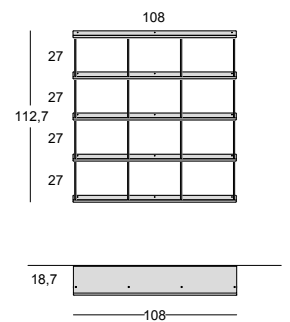



Configuration 19

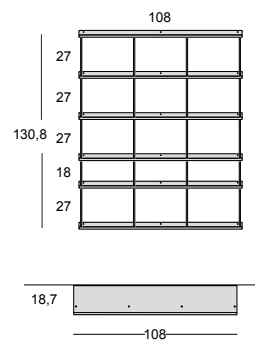

# KITCHEN SOLUTIONS

Non solo libri: All-Over è progettata anche per diventare una dispensa a vista, una credenza moderna oppure un'originale porta bicchieri / bottiglie in cucina. Il pratico accessorio porta bicchieri si alterna alle mensole e personalizza sia l'estetica, sia la funzionalità dell'arredo.

Not just books: All-Over is also designed to become a frontless cupboard, a modern larder or an original stemware / glass / bottle rack and holder for the kitchen. The practical stemware rack accessory alternates with shelves to customise both the look and the functions of the arrangement.

## Configuration 20

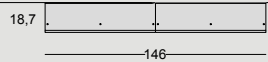
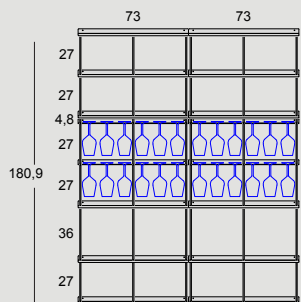





Configuration 21

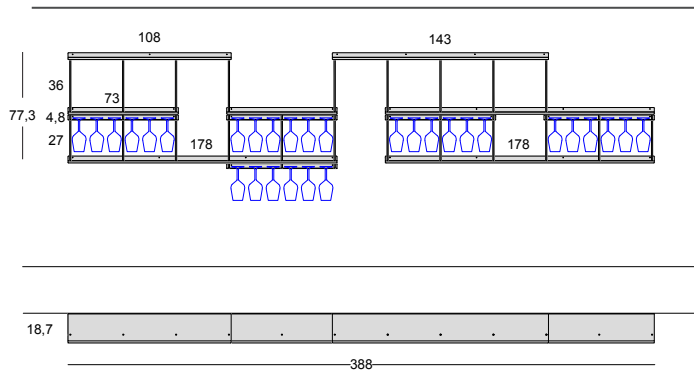



# KITCHEN SOLUTIONS

Configuration 22

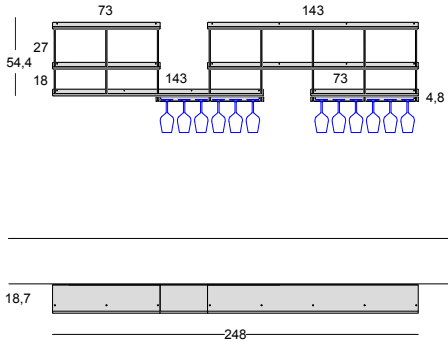





**Configuration 23**

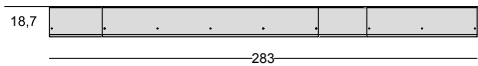
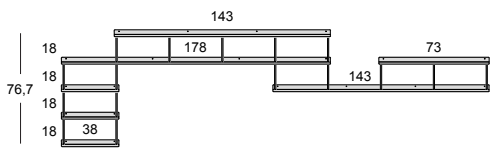



**Configuration 24**

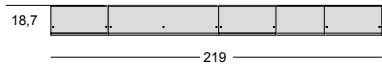
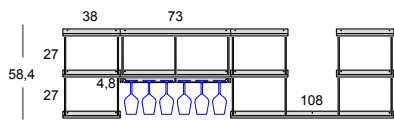

# BEDROOM

Una libreria in camera da letto è sempre un'ottima scelta d'arredo. Per grandi o piccoli spazi, All-Over sa adattarsi a ogni tipo di parete dove può assumere la forma regolare di una classica libreria oppure di un complemento dalle geometrie originali. Di giorno come di notte.

Installing a bookcase in the bedroom is always an excellent idea. Suitable for large or small spaces, All-Over can adapt to any type of wall where it can take on the regular shape of a traditional bookcase or the appearance of an accessory made up of original geometric shapes. By day and by night.

## Configuration 25

---

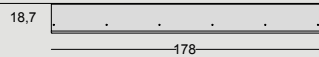
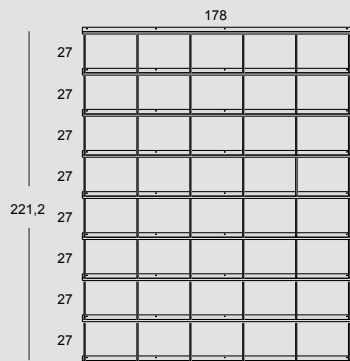







**Configuration 26**

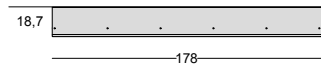
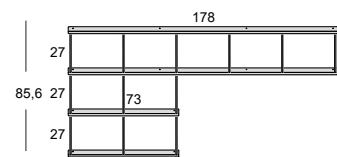

# BATHROOM

Chi l'ha detto che una libreria non può stare in bagno?! All-Over si prende lo spazio che merita anche qui! Pratica per riporre gli asciugamani e avere tutto ciò che serve a portata di mano, bella da vedere vicino a un lavabo o sopra la vasca da bagno.

Who on earth said that a bathroom is no place for a bookcase?! In this room too, All-Over takes up all the space it deserves! A practical place to put towels on and keep everything close at hand, it also adds a touch of beauty when installed next to a washbasin or above the bathtub.

## Configuration 27

---

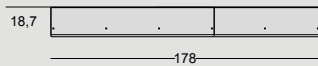
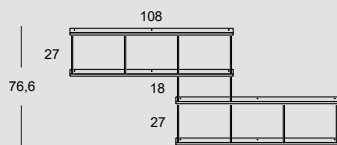



## Configuration 28

---

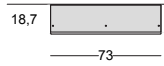
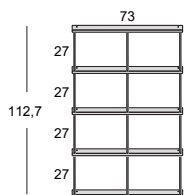



# BATHROOM

## Configuration 29

---

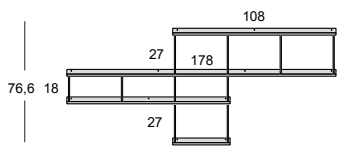



# BATHROOM

## Configuration 30

---

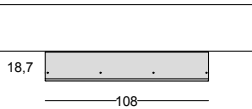
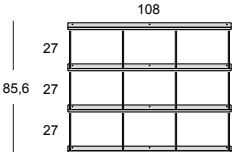



# OFFICE

Verticale o orizzontale, in ufficio la libreria trova l'ambiente ideale per mostrarsi in tutta la sua funzionalità. Grazie alla struttura a tondini con mensole sottili, All-Over è visivamente leggera anche nelle grandi dimensioni: mai ingombrante, sempre d'effetto.

In a vertical or horizontal configuration, the office is the ideal place for the bookcase to show off all its practicality. Thanks to its tubular structure with slim shelves, All-Over has a visually light appearance, even when it is large: it's never overwhelming yet always stunning.

## Configuration 31

---

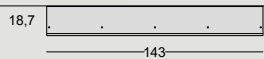
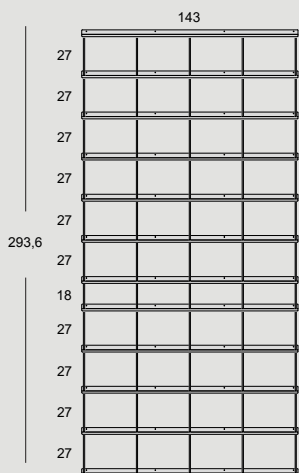



FINE WINES  
Gardens in France

Dior  
ESSENTIALS  
ESSENTIALS

THE ART OF THE  
THE ART OF THE

WABI-SABI  
Wabi-sabi

WABI-SABI  
Wabi-sabi

WABI-SABI  
Wabi-sabi

# OFFICE



Configuration 32

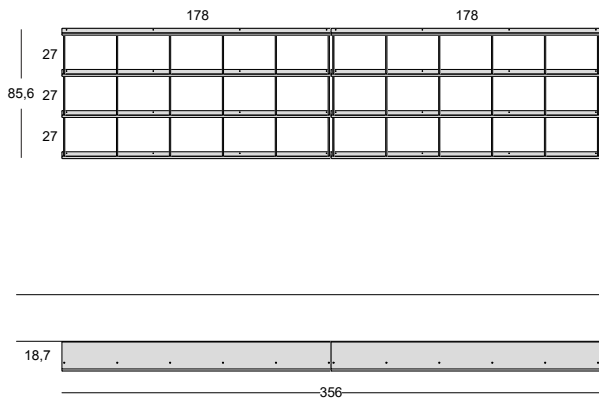



## ALL-OVER MODULARITY

Scenografica, versatile e funzionale, è la libreria modulare All-Over, un sistema di arredo flessibile e personalizzabile a propria misura.

Eye-catching, versatile and functional, the All-Over modular shelving system is flexible and can be customised to suit your needs.



---

## FINITURE - FINISHES

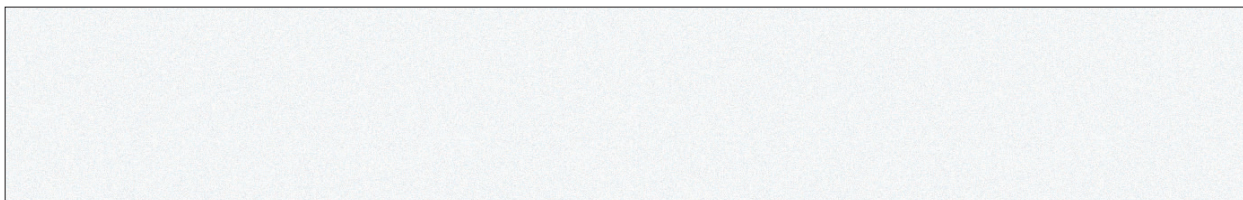

Laccato bianco gofrato (RAL 9003)  
Embossed white lacquer (RAL 9003)



Laccato antracite gofrato (RAL 9005)  
Embossed anthracite lacquer (RAL 9005)

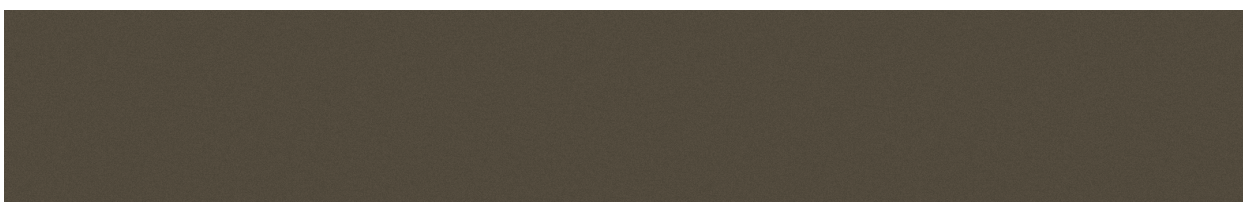

Laccato bronzo liscio  
Plain bronze lacquer

---

## MENSOLE - SHELVES

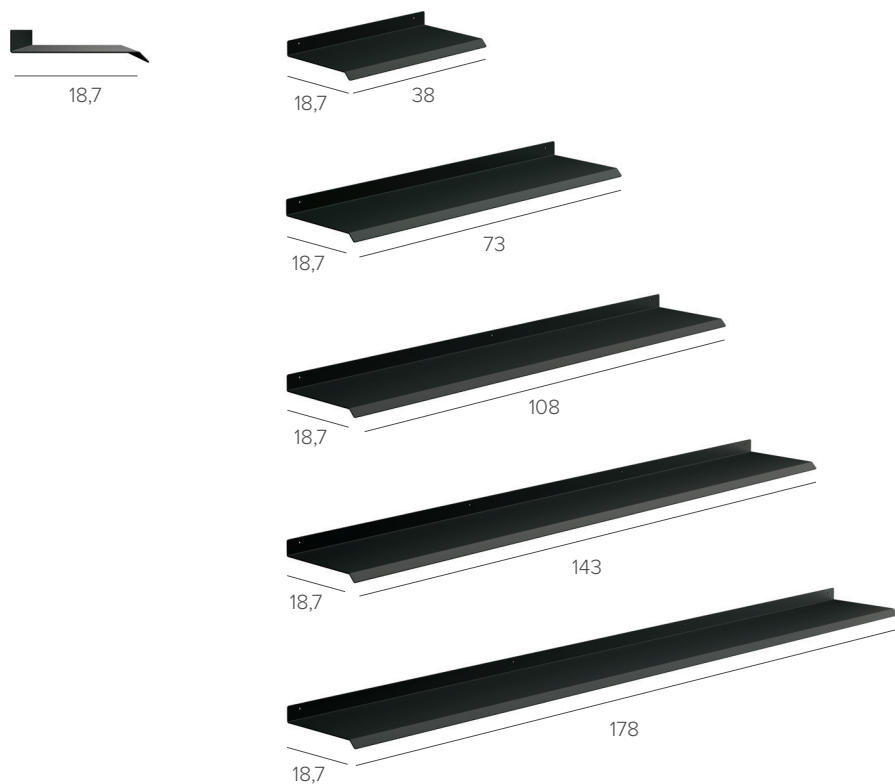

---

## PORTA BICCHIERI - STEMWARE RACKS

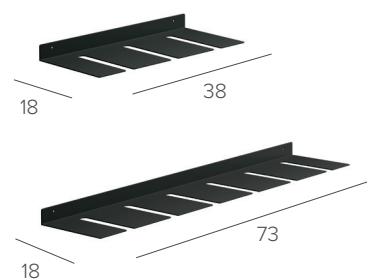

---

## DISTANZIALI - SPACERS $\varnothing$ 0,8 cm

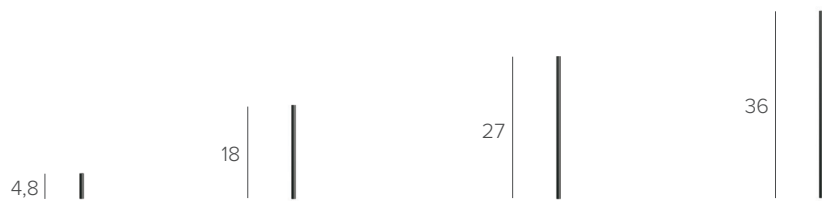

---

## VITI - SCREWS



Viti brunate per  
finitura nero e bronzo

Burnished screws for  
black and bronze  
finishes



Viti zincate  
per finitura bianco

Galvanized screws  
for white finish

La riproduzione dei colori delle immagini grafiche contenute in questo catalogo è indicativa della resa cromatica reale sul supporto stampato. Minime differenze non sono considerate difetto.

The colour reproductions of graphic images shown in this catalogue are merely indicative of the actual colours used, shown on a printed substrate. Minimal differences cannot be regarded as defects.



### **contact**

ordini.wall@caoscreativo.it

Tel. +39 0445 1654438

caoscreativo.it